

**South Carolina Department of
Transportation**

REQUEST FOR PROPOSALS
(FINAL)

Interstate 77 Widening & Rehabilitation from
MM 15 to MM 27

Project ID P027002

A Design-Build Project

Richland County
South Carolina

JULY 23, 2015

INDEX

**Interstate 77 Widening and Rehabilitation
from MM 15 to MM 27**

Richland County, South Carolina

A Design-Build Project

Project ID P027002

INDEX

Request for Proposals

Attachment A – Agreement

- Exhibit 1. Cost Proposal Bid Form
- Exhibit 2. Schedule of Values
- Exhibit 3. Scope of Work
- Exhibit 4. Project Design Criteria
 - 4a. Roadway
 - 4b. Structures
 - 4c. Pavement
 - 4d. Traffic
 - Part 1 – Signing and Pavement Markings
 - Part 2 – Work Zone Traffic Control
 - Part 3 – Traffic Signals
 - Part 4 – Intelligent Transportation System (ITS)
 - 4e. Hydraulic
 - 4f. Geotechnical
 - 4g. Environmental
- Exhibit 5. Special Provisions
- Exhibit 6. Federal-Aid Provisions Project Supplemental Specifications
- Exhibit 7. Escrow Documents
 - 7a. Escrow Release
 - 7b. Escrow Agreement
- Exhibit 8. Railroad Information

Attachment B – Project Information Package

REQUEST FOR PROPOSALS

South Carolina Department of Transportation

REQUEST FOR PROPOSALS
Final

A DESIGN-BUILD PROJECT

Project ID P027002

Interstate 77 Widening and Rehabilitation
from MM 15 to MM 27

Richland County, South Carolina

July 23, 2015

Table of Contents

I. PURPOSE OF REQUEST FOR PROPOSALS3

II. OVERVIEW3

A. PROJECT DESCRIPTION3

B. PROJECT INFORMATION.....3

C. SCHEDULE AND LIQUIDATED DAMAGES.....4

D. RFP COMMITTAL.....4

E. DISADVANTAGED BUSINESS ENTERPRISES.....4

F. ON-THE-JOB TRAINING REQUIREMENT.....4

G. NEPA DOCUMENT.....5

III. GENERAL INSTRUCTIONS.....5

A. DESIGN BUILD PROCUREMENT METHOD5

B. RFP FOR INDUSTRY REVIEW5

C. FINAL RFP.....5

D. QUESTIONS, CLARIFICATIONS, AND CONFIDENTIAL ONE-ON-ONE MEETINGS6

E. ALTERNATIVE TECHNICAL CONCEPTS.....7

F. STIPENDS.....12

G. PROPOSAL SUBMITTAL.....12

IV. PROPOSAL DEVELOPMENT.....13

A. TECHNICAL PROPOSAL14

B. COST PROPOSAL.....16

C. CONFIDENTIALITY OF PROPOSALS16

D. NONCOLLUSION AND EQUAL EMPLOYMENT OPPORTUNITY CERTIFICATION.....17

V. EVALUATION OF PROPOSALS17

A. PROPOSAL REVIEW COMMITTEE17

B. PROPOSAL REVIEW17

C. TECHNICAL EVALUATION18

D. PRESENTATIONS18

E. CLARIFICATIONS19

F. OPENING OF COST PROPOSALS/BID OPENING MEETING19

G. TOTAL ADJUSTED BID DETERMINATION.....20

VI. SELECTION OF CONTRACTOR20

VII. GENERAL INFORMATION21

VIII. MILESTONES23

IX. COST PROPOSAL BID FORM.....24

X. NON-COLLUSION CERTIFICATION25

XI. EQUAL EMPLOYMENT OPPORTUNITY CERTIFICATION26

XII. STIPEND ACKNOWLEDGEMENT FORM.....27

XIII. STIPEND AGREEMENT28

XIV. COMMITMENT MATRIX FORM30

I. PURPOSE OF REQUEST FOR PROPOSALS

The purpose of this Request for Proposals (“RFP”) is to select a PROPOSER to perform the Project services described in this RFP. SCDOT desires that this Project be constructed in a very efficient and timely manner. The proposed Project services are hereinafter referred to as the “Project”. “PROPOSER,” as used here, includes a firm or firms, consortia, partnerships, joint ventures, and other legal entities, which have been requested by SCDOT to submit a Proposal in response to this RFP. The PROPOSER shall become the CONTRACTOR if awarded the Contract.

It is not the intention of the SCDOT to receive complete detailed Project analysis and design prior to the selection of a PROPOSER and the later execution of an agreement. Rather, the response to this RFP shall provide sufficient information to be evaluated by SCDOT to determine if the proposal is in accordance with the specified process and criteria. The Proposal shall be specific enough on assumptions used in its preparation so as to provide the basis for determining a final agreement.

The information obtained under this RFP will become the property of SCDOT without restriction or limitation on its use. With the exception of Alternative Technical Concepts (ATCs), SCDOT shall have unrestricted authority to publish, disclose, distribute, or otherwise use in whole or in part any reports, data, or other materials prepared under this RFP. SCDOT shall retain ownership of all plans, specifications, and related documents.

II. OVERVIEW

A. Project Description

The purpose of this Project is to improve operational efficiency, to accommodate future traffic volumes, and to improve existing pavement along the I-77 corridor. SCDOT proposes to widen and rehabilitate Interstate 77 (I-77) from just south of Interstate 20 to S-59 (Blythewood Road) in Richland County.

SCDOT intends to enter into a contract for services as detailed in **the Agreement and Agreement Exhibits**.

The PROPOSER shall be responsible for meeting all Project requirements, specifications, and other applicable criteria as set forth in “Attachments A and B”.

B. Project Information

Project Information, containing electronic files applicable to the Project, will be posted on the SCDOT Design Build website. The Project Information Package will include information describing the work, which has been performed by SCDOT prior to entering into the contract for the Project. The Project Information Package is attached to this RFP as “Attachment B”. “Attachment B” may contain additional information not provided at the RFQ stage. Data,

reports, plans, electronic files, and any other items supplied in Attachment B which is posted on the SCDOT Design Build website are for information only. SCDOT shall not be liable for the reliability or accuracy of the information contained therein. Any changes to the documentation provided shall be identified by an addendum to this RFP. PROPOSERS shall acknowledge receipt of addendums in their response to this RFP. **It is the PROPOSER'S responsibility to check the website regularly for updates, modifications and additional documentation pertaining to this procurement.**

PROPOSERS are encouraged to visit the Project site and to make any additional subsurface explorations or soil tests that PROPOSER may desire for purposes of preparing the Proposal. The PROPOSER shall obtain any permits or permissions required prior to any additional subsurface exploration.

C. Schedule and Liquidated Damages

It is the intent of SCDOT to complete the Project in a timely manner with minimum interference to normal traffic operations. Liquidated damages shall be assessed in accordance with Article IV of the Agreement. The Baseline CPM Schedule shall be submitted in accordance with Article IV of the Agreement.

SCDOT will issue the Notice to Proceed no later than 45 days from the effective date of the Agreement. The PROPOSER must identify the time required for the construction time of the Project on the Cost Proposal Bid Form.

As defined in Article IV of the Agreement, Construction Time will begin when SCDOT issues the Notice to Proceed for the Project and will end with Substantial Work Completion of the Project.

D. RFP Committal

The submittal of a Proposal in response to this RFP shall constitute the PROPOSER'S agreement to enter into a contract with SCDOT for the completion of the Project under the terms set forth in the Agreement and Agreement Exhibits attached hereto as "Attachment A".

E. Disadvantaged Business Enterprises

PROPOSER shall comply with Special Provision Disadvantaged Business Enterprises (DBE) for Federal-aid Design Build Projects, (**EXHIBIT 5**) which incorporates by reference the Disadvantage Business Enterprises (DBE) Supplemental Specification (DBE Supplemental Spec). The **Agreement, Article XVIII** identifies and sets forth the DBE goal for this Project.

F. On-The-Job Training Requirement

The Contract for this Project contains an On-The-Job Training Requirement. The PROPOSER shall comply with the requirements of the Specific Equal Employment Opportunity Responsibilities Training Special Provisions within the Federal Aid Supplemental Specifications. **Article XIX of the Agreement** identifies the number of persons to be trained under the On the Job Training Program. The Proposer shall submit its plan for On-the-Job Training to SCDOT for written approval prior to commencing construction activities.

G. NEPA Document

As of the release of this RFP for Industry Review, the Categorical Exclusion (CE) for the Project has not been approved by FHWA. The CE is under review by FHWA and therefore the contents of this RFP are subject to change. SCDOT will have an approved CE prior to issuance of the FINAL RFP. After approval of the CE, any revisions, if necessary, to the RFP for Industry Review as a result of the approved NEPA document will be highlighted in the FINAL RFP.

III. GENERAL INSTRUCTIONS

A. Design Build Procurement Method

For this Design Build Project, SCDOT chose the two-phased procurement method. Phase 1, which identified a short-list of qualified PROPOSERS, is complete.

In Phase 2, SCDOT will invite each of the short-listed PROPOSERS to submit their Proposals for completion of the Project. After evaluation of the Proposals, SCDOT plans to award and execute a contract with a single PROPOSER. Phase 2 includes the following steps:

1. SCDOT releases **RFP for Industry Review**
2. SCDOT conducts reviews & meetings with PROPOSERS to clarify/revise RFP
3. SCDOT releases **Final RFP**
4. PROPOSERS submit **Preliminary Alternative Technical Concepts (ATC's)**
5. SCDOT conducts meetings with PROPOSERS to discuss Preliminary ATC's
6. PROPOSERS submit **Formal ATC's**
7. SCDOT approves/disapproves ATC's
8. PROPOSERS submit **Proposals**
9. SCDOT evaluates Proposals
10. SCDOT selects a Contractor

These steps will be carried out following the Milestones in Article VIII. The following paragraphs provide information detailing various steps of the process.

B. RFP for Industry Review

It is the intent of SCDOT to issue an RFP for industry review during the initial stages of this RFP process to allow industry review and comment. The purpose of the RFP for industry review step is to identify those areas of the RFP that may be in conflict with each other and to point out and clarify ambiguities in the RFP. The First Confidential One-on-One Meetings may be scheduled with the PROPOSERS to facilitate this purpose.

C. Final RFP

After completion of the Questions, Clarifications, and First Confidential One-on-One Meetings stage as set forth below in Paragraph D, SCDOT may incorporate the PROPOSERS' comments into the RFP, and a Final RFP will be issued. Items that are revised, inserted, or deleted will be highlighted in the Final RFP. After issuance of the Final RFP, the ATC stage will begin.

PROPOSERS shall submit their responses to the Final RFP in accordance with the Milestone Schedule.

D. Questions, Clarifications, and Confidential One-On-One Meetings

Once the RFP for Industry Review is issued, the PROPOSERS may submit questions or seek clarification relating to the RFP. Questions or requests for clarification shall be in writing from only the PROPOSER's POC and must be received by SCDOT's POC in accordance with the Milestone Schedule. PROPOSER's questions shall detail the specific section and page number of the RFP at issue. SCDOT may hold the First Confidential One-on-One Meetings following the review of submitted comments or questions prior to Final RFP release. SCDOT reserves the right to accept or not accept questions received after the milestone deadlines. Changes made to the RFP for Industry Review as a result of the written questions will be tracked by highlighting the changes in the Final RFP. Verbal responses from SCDOT are for information only and not binding. All questions submitted and responses provided will be furnished to PROPOSERS by posting them on the SCDOT Design Build website, located at:

http://www.scdot.org/doing/constructionLetting_designBuild.aspx.

SCDOT's answers to PROPOSERS's questions are for general information only, do not constitute legal or other advice and do not amend, or form part of the Final RFP. SCDOT will review all questions and/or requests for clarification received and, if it deems appropriate, in its sole discretion, may incorporate them in the Final RFP. PROPOSERS may request the First Confidential One-on-One Meeting when they submit their question and clarification. The purpose of the meeting will be limited to editing the RFP for Industry Review. If time allows, other questions regarding the RFP process or the content of individual proposals may be discussed. Oral explanations or instructions will not be binding. Changes made to the RFP for Industry Review as a result of the written questions and one-on one meeting will be tracked by highlighting the changes in the Final RFP. Verbal responses from SCDOT are for information only and not binding. Nothing discussed at the one-on-one meetings shall change the requirements of the RFP.

Questions or clarifications concerning the RFP or Project shall be directed from only the PROPOSER's POC to:

Mr. William "Tyke" Redfearn, III, P.E.
SCDOT Point of Contact (POC)
South Carolina Department of Transportation
955 Park Street, Room 421
Post Office Box 191
Columbia, South Carolina 29202-0191
803-737-1430
redfearnwt@scdot.org

Once the Final/Revised RFP is issued, SCDOT will offer the Second Confidential One-on-One Meetings at the request of the PROPOSERS. By the date specified in the Project Milestones, PROPOSER shall submit written questions and topics for discussion and request a meeting in writing addressed to the POC at the above address. The purpose of the Second Confidential One-on-One Meetings is to provide the PROPOSER with the opportunity to confidentially discuss the

contents of his proposal with SCDOT personnel. Preliminary Concepts may be discussed during the Second Confidential One-on-One Meetings. SCDOT will determine if questions submitted to or asked at the one-on-one meetings are considered confidential. No additional time will be allowed to research answers. Nothing discussed at the one-on-one meetings shall change the requirements in the RFP. SCDOT will answer the questions at the meeting verbally if possible. Verbal responses are for information only and are not binding. If necessary, written responses that are determined to be of a non-confidential nature will be provided in an addendum to the RFP.

Confidential One-on-One Meetings will be offered only on the dates provided in the Milestone Schedule. PROPOSERS must submit a written request for a meeting not later than five (5) business days prior to the date shown on the Milestone Schedule. SCDOT will reserve one (1) hour of meeting time for each PROPOSER that requests a meeting, and SCDOT will give time of day preference in the order that requests are received.

E. Alternative Technical Concepts

An Alternative Technical Concept (ATC) is a confidential request by a PROPOSER to modify a contract requirement, specifically for that PROPOSER, prior to the Proposal due date. The ATC process provides an opportunity for design-build proposals to promote innovation, find the best solutions, and to maintain flexibility in the procurement process. ATC's are evaluated for approval or denial by SCDOT within the deadline set forth in the RFP Milestone Schedule. In order to be approved, an ATC must be deemed, in SCDOT's sole discretion, to provide a Project that is "equal or better" on an overall basis than the Project would be without the proposed ATC. Concepts that simply delete scope, lower performance requirements, lower standards, conflict with environmental commitments, or reduce contract requirements are not acceptable as ATC's. SCDOT reserves the right in its sole discretion to reject any ATC. No ATC shall be included in the proposal unless approved by SCDOT in writing prior to the proposal submission deadline.

1. Submittal of ATCs:

- a. **Preliminary Concepts:** Preliminary concepts may be submitted that present a description adequate for SCDOT to assess the benefits of the concept. Preliminary concepts may be submitted by email from the Design Build Team Point of Contact to the SCDOT Point of Contact and are intended to be an informal inquiry by the PROPOSER to explore a concept and a quick method by SCDOT to review and comment on potential development of ATC prior to investment of time and resources by the PROPOSER. Submission of preliminary concepts does not change or extend the submission deadline of formal ATCs. SCDOT reserves the right to ask PROPOSER to clarify its email. If a preliminary concept receives a favorable response from SCDOT, PROPOSER can elect to submit a formal ATC in accordance with these procedures. A favorable response by SCDOT in no way guarantees that the concept will become an approved ATC. The favorable response may be subject to conditions. **PROPOSER shall be limited to two packages of preliminary concepts and the total number of preliminary concepts shall not exceed twenty (20).** A package is a submittal of one (1) or more ATC's. If more than one preliminary concept on the same topic

has been received from multiple PROPOSERS, SCDOT has the right to revise the RFP to include that concept as an addendum to the RFP.

- b. ATC Identification: ATC will be submitted by the PROPOSER and evaluated by SCDOT as set forth in the RFP Milestone Schedule. All ATCs shall be submitted in writing to the POC identified in the RFP with a cover letter clearly identifying the submittal as a request for review of an ATC under this RFP. If the PROPOSER does not clearly designate its submittal as an ATC, the submission will not be treated as an ATC by SCDOT.
- c. **A maximum number of ten (10) ATCs may be submitted to SCDOT by the PROPOSER for consideration.**

2. Contents of ATC Submittal:

Each ATC submittal shall include one (1) electronic and one (1) hard-copy and shall include the following:

- a. **Description**: A detailed description and schematic drawings of the configuration of the ATC or other appropriate descriptive information (including, if appropriate, specifications, construction tolerances, special provisions, proposed bridge types, product details, and a traffic operational analysis);
- b. **Usage**: Locations where and an explanation of how the ATC would be used on the Project;
- c. **Deviations**: List in table format, all references to any requirements of the RFP or to any requirements of the Contract Documents that are inconsistent with the proposed ATC. Include an explanation of the nature of the proposed deviation and a request for approval of such deviations or a determination that the ATC is consistent with the requirements of the RFP;
- d. **Justification**: Justify use of the ATC and why the deviations from the requirements of the RFP should be allowed;
- e. **Schedule**: Proposed changes to the Project schedule if applicable;
- f. **Impacts**: Identify potential impacts on vehicular traffic, safety, community, utilities, right of way, and the environment;
- g. **History**: A detailed description of other projects where the ATC has been used under comparable circumstances, the success of such usage, and names and telephone numbers of project owners that can confirm such statements;
- h. **Risks**: A description of added risks to SCDOT and other persons associated with implementing the ATC;

- i. **Costs:** An estimate of the impact of the ATC on the Proposal Price and the ATC implementation costs to SCDOT, FHWA, CONTRACTOR, or other person during construction, maintenance and operations;
- j. **Quality:** A description of how the ATC is equal or better in quality and performance than the requirements of the RFP;
- k. **Operations & Maintenance:** Any changes in operation or maintenance requirements associated with the ATC,

3. Review of ATCs:

- a. Initial Review: SCDOT will review each ATC submitted within ten (10) business days of ATC receipt. A **business day** is hereby defined as a day in which SCDOT Headquarters is open for business.
- b. More Information Needed: If within five (5) business days of receipt of the ATC SCDOT needs more information to determine whether or not the ATC will be approved or not approved, SCDOT will submit written questions to the PROPOSER and/or request a one-on-one meeting in order to better understand the details of the formal ATC.
 - i. **Questions:** SCDOT may submit written questions to the PROPOSER within five (5) business days of receipt of the ATC. PROPOSER has three (3) business days to remit answers. Within four (4) business days of receipt of the answers, SCDOT shall respond to the ATC.
 - ii. **One-on-One Meetings:** ATC meeting may be scheduled by SCDOT within five (5) business days of receipt of the ATC. Confidential One-on-one meeting(s) may be scheduled to fully understand the details of any formal ATCs. These meetings will be restricted to those persons involved in the review of the ATC and limited to discussions of the PROPOSER'S ATC approach. The purpose of this meeting is to discuss the proposed changes, answer questions, and other relevant issues. Verbal responses are for information only and are not binding. Nothing stated at any ATC meeting(s) will modify the RFP or Contract documents. SCDOT reserves the right to disclose to all PROPOSERS any issues raised during the ATC meeting(s), either in the Final RFP or in an addendum. However, SCDOT will not disclose any information pertaining to an individual PROPOSER'S ATCs or other technical concepts to other Proposers. SCDOT will issue a written response to PROPOSER regarding its ATC.
- c. No Response from SCDOT: If the PROPOSER does not receive correspondence from SCDOT within ten (10) business days of SCDOT's receipt of the ATC, the ATC is deemed rejected by SCDOT, unless written notification to extend this period is given by SCDOT.

- d. Conditional Response by SCDOT: If SCDOT issues a conditional answer; an additional ten (10) business days are added to the ten (10) business Day Review period: 5 business days for PROPOSER to respond to the condition, and 5 business days for SCDOT to submit its final response to the ATC.

4. Determination of SCDOT

- a. SCDOT will make one of the following written determinations with respect to each properly submitted ATC:
 - i. The ATC is approved, in its entirety or in part;
 - ii. The ATC is not approved;
 - iii. The ATC is not approved in its present form, but may be reconsidered for approval upon satisfaction, in SCDOT's sole discretion, of certain identified conditions that must be met or certain clarifications or modifications that must be made by PROPOSER. The PROPOSER shall not have the right to incorporate this ATC into the Proposal unless and until the ATC has been resubmitted within the time limits in the RFP, with the conditions, clarification and modifications satisfied, and SCDOT has unconditionally approved the revised ATC; or
 - iv. The submittal does not qualify as an ATC but appears eligible to be included in the Proposal without an ATC (i.e., the concept appears to conform to the RFP and to be consistent with other contract requirements).
 - v. The ATC is deemed to take advantage of an error or omission in the RFP, or other documents incorporated into the contract by reference, the ATC will not be considered, and the RFP will be revised to correct the error or omission.
 - vi. More than one formal ATC has been received on the same topic and SCDOT has elected to exercise its right to issue an addendum to the RFP to include that topic.
- b. Once an ATC has been approved, only the entire ATC is eligible for inclusion into the Proposal. The inclusion of partial ATCs into a Proposal is not allowed, unless the individual ATC's have received separate approval by SCDOT
- c. Each PROPOSER, by submittal of its Proposal, acknowledges that the opportunity to submit ATCs was offered to all PROPOSERS, and waives any right to object to SCDOT's determinations regarding acceptability of ATCs.

5. Incorporation into Proposal

- a. A PROPOSER has the option to include any or all approved ATC's in its Proposal. If SCDOT responded to an ATC by identifying conditions for

approval, PROPOSER may not incorporate such ATC into the Proposal unless all conditions have been met. Copies of SCDOT's ATC approval letters for each incorporated ATC shall be included in the Technical Proposal appendices. Proposals with or without ATCs will be evaluated against the same technical evaluation factors set forth in the EVALUATION OF PROPOSALS section, and the inclusion of an ATC, including an ATC that provides technical enhancements, may or may not receive a higher technical rating. SCDOT approval of an ATC shall not be considered a guaranty that the proposal incorporating the ATC will be selected. SCDOT's rejection of an ATC will not entitle the PROPOSER to an extension of the Proposal submission deadline on the Milestone Schedule or claim for additional costs or delays, including development costs, loss of anticipated profits, or increased material or labor costs.

- b. The Total Cost to Complete shown in the Cost Proposal should reflect any incorporated approved ATCs.
- c. Except for incorporating approved ATCs, the Proposal may not otherwise contain exceptions to or deviations from the requirements of the RFP.

6. Value Engineering

An approved ATC that is not incorporated into the proposal will not be considered a pre-approved value engineering change.

7. Abandonment of ATC by PROPOSER

If the approved ATC is abandoned by the PROPOSER, is unable to obtain required approvals, is otherwise proved to be infeasible, or fails to be constructed for any reason, the successful PROPOSER is obligated and required to complete the Project utilizing the original RFP requirements at the awarded cost, and shall be responsible for any redesign costs.

8. SCDOT's use of Concepts Contained in an ATC

SCDOT expressly reserves the right to adopt and use any ATC, approved or disapproved, by the successful PROPOSER on this contract or other contracts administered by SCDOT. By submitting a Proposal, all unsuccessful PROPOSERS acknowledge that upon acceptance of the designated stipend, all approved or disapproved ATC's may be included in this contract or other contracts administered by SCDOT and shall become the property of SCDOT without restriction on use. Prior to contract execution, limited negotiations may be conducted as necessary to incorporate the ideas and concepts from unsuccessful PROPOSERS, provided a stipend is accepted by the unsuccessful offerer.

9. PROPOSER Obligations.

The successful PROPOSER, in addition to performing all other requirements of the Contract Documents, shall:

- a. Obtain and pay the cost of obtaining all required approvals including approvals required to implement any approved ATC(s) incorporated into the Contract Documents;
- b. Obtain and pay the cost of obtaining any third party approvals required to implement any approved ATC(s) incorporated into the Contract Documents; and
- c. Unless otherwise noted in the Contract, be responsible for all costs and/or delays of any nature associated with the implementation of any approved ATC incorporated into the Contract Documents.
- d. Should SCDOT revise the RFP after a formal ATC has been approved, be solely responsible for reviewing the RFP and determining if the ATC deviates from the revised requirements. If required, the PROPOSER must submit a request for approval of all additional variances required within five (5) business days of receipt of the revised RFP.

F. Stipends

By submitting a Proposal in response to the RFP, the PROPOSER acknowledges the following:

1. It is the intent of SCDOT to award a stipend of \$40,000.00 to each responsible and responsive PROPOSER subject to the terms of the Stipend Agreement set forth in ARTICLE XIII of the RFP.
2. PROPOSERS shall indicate on the Stipend Acknowledgement Form in Article XII of the RFP whether it elects to receive a stipend. The Stipend Acknowledgement Form shall be signed and returned with the unsealed Technical Proposal. The Stipend Acknowledgment Form will not count against the specified page limit.
3. If PROPOSER elects to receive a stipend, the Stipend Agreement shall be signed by PROPOSER and submitted as part of the unsealed Technical proposal. The Stipend Agreement will not count against the specified page limit.

G. Proposal Submittal

PROPOSERS are REQUIRED to upload their submittals, including the Technical Proposal, signed forms, and appendices, online through ProjectWise in PDF format. Only one completed submittal per team will be accepted and shall be uploaded by either the lead contracting entity or lead design firm. Please be advised of the time required to set up new account. All requests for new accounts must be received 72 business hours prior to the proposal deadline indicated in the milestone schedule. More information is available at http://www.scdot.org/doing/constructionletting_projectwise.aspx.

PROPOSERS are to physically deliver and submit ten (10) printed and bound hard copies of the Technical Proposal, signed forms, and appendices. PROPOSERS are to physically deliver one (1) sealed, printed copy of the Cost Proposal. Please deliver to:

Jeff Elliott, P.E.
Contract Administration Engineer
South Carolina Department of Transportation
955 Park Street, Room 333
Post Office Box 191
Columbia, South Carolina 29202-0191

PROPOSERS are responsible for affecting delivery by the deadline dates. Late submissions will be rejected without opening. SCDOT accepts no responsibility for misdirected or lost proposals.

IV. PROPOSAL DEVELOPMENT

Proposals must be submitted separately in two parts, a Technical Proposal and a Cost Proposal. The Technical Proposal shall contain no more than twenty (20) pages, excluding any plans signed forms, and appendices. Any Conceptual Plans developed by the PROPOSER to accompany the PROPOSER's responses and commitments, that are not included in the twenty (20) page narrative, shall be incorporated in the Technical Proposal as Appendices. Required forms and approved ATC's used in preparing the PROPOSER's Cost Proposal shall also be incorporated in the Technical Proposal as Appendices. The Technical Proposal shall be single sided, with minimum twelve-point (12) Times New Roman font and double line spacing for text. The Cost Proposal shall be bound and sealed separately from the Technical Proposal. The Cost Proposal shall be clearly marked as "Confidential Proprietary Information" by the PROPOSER and shall include the completed Cost Proposal Bid Form. Responses shall address all of the items listed below. If a PROPOSER does not, at a minimum, submit responses to these items, the submittal may be considered non-responsive and returned without further review/evaluation. In order to meet the minimum requirements of this RFP, PROPOSER must provide responses to each of the items listed. **Beyond the minimum requirements**, a maximum of 100 quality credit points are available to the PROPOSER based on the commitments to the bolded items below. **Responses must be in the form of commitments in order to receive quality credit. All Project commitments above and beyond the requirements of the RFP, supported in the Technical Proposal and appendices, shall be summarized on the Commitment Matrix Form, provided herein, in a clear and concise manner. The Commitment Matrix Form will not count against the specified page limit. If the amount of commitments requires more than one form, multiple forms may be submitted to include all commitments.** Conceptual plans that conflict with RFP requirements, and are not submitted under the ATC process, may result in the proposal being deemed non-responsive. Any concepts that conflict with the RFP specifications discovered after award of the Project, and which are not approved as an ATC, shall not prevail over RFP specifications. Point values for each of the bolded items are shown at the end of each item.

A. Technical Proposal

At a minimum, the Technical Proposal shall include a narrative describing the Project Delivery and Approach, **and** the PROPOSER's Commitments above and beyond the minimum requirements of the RFP, **and appendices**. The Technical Proposal Appendices shall include Conceptual Plans, required forms, and approved ATCs being incorporated into the PROPOSER's Cost Proposal. The Technical Proposal narrative and the Conceptual Plans, included in the Technical Proposal Appendix, will be utilized to evaluate the responses below.

In the technical proposal narrative, PROPOSERS shall respond to the following items and shall develop the narrative in the following sequence:

1. Describe the Project Delivery & Approach by discussing/providing the following:
 - a. Identify construction methods for the project. At a minimum, describe the plan for performing the work in the medians and on the bridges between I-20 and Windsor Lake and work in the medians at the SC 277 Interchange.
 - b. Identify the proposed schedule for implementing the Project. Include the sequence of construction and material and equipment staging plan. Describe assurances and ability to complete the project within the proposed time. The Cost Proposal includes Construction Time so the narrative may not include the actual proposed time. The PROPOSER may use generalities to reference the proposed time.
 - c. Describe the proposed design submittal process and sequencing and the proposed plan that will minimize the number of submittals and will allow SCDOT to conduct efficient and complete reviews.

In order to receive qualitative points, the PROPOSER may respond to the following questions within the 20 page limit to describe the commitments above and beyond the requirements of the RFP. **The 100 total quality credit points available will be based on the commitments, above and beyond minimum RFP requirements, included in the responses to the items below.**

2. Describe the PROPOSER's innovations and commitments to minimizing impacts to traffic and provide any drawings (if not clearly illustrated in conceptual plans) to illustrate the concept including but not limited to the following: (50 points)
 - a. Minimize temporary lane or ramp **closures detours**
 - b. Minimize the number of traffic shifts **for mainline I-77**
 - c. **Minimize impacts of construction activities in the median by limiting median access points along I-77 mainline and minimize frequency of reducing or limiting ingress/egress from mainline to the median**
 - d. Minimize or avoid traffic impacts to Killian Road ramps
 - e. Minimize or avoid traffic impacts to I-20

- f. Minimize impacts of US 21 Bridge work and minimize or avoid use of temporary signal
- g. Early completion of work required at the merge of SC 277 northbound onramp.

3. Describe any additional improvements, tasks, commitments, and/or innovations that will be included in the Project including but not limited to: (50 points)

- a. Additional warranties, enhancements, and upgrades. Potential items could include landscaping, extension of roadway items such as resurfacing on mainline and/or side roads, installation/replacement of signage, increased public involvement, etc.
- b. Commitments of materials, designs, and construction methods that would minimize maintenance costs in the future to the SCDOT and benefit the Project. Potential commitments could involve installing low maintenance drainage components and expansion joints, installing longer-life pavement, reduction of vegetation management mitigation measures to prevent concrete joints from propagating through HMA surfacing, etc.
- c. If Proposer's plan utilizes local roads for access, hauling, etc., describe your commitment to repair any resulting damage to those roads.
- d. Describe any additional community involvement/public relations commitments above and beyond the minimum requirements.

All Project commitments above and beyond the requirements of the RFP, supported in the technical narrative, shall be summarized in the Commitment Matrix Form, provided at the end of this document, in a clear and concise manner and shall become part of the contract. The completed Commitment Matrix Form shall be included as an Appendix of the PROPOSER's Technical Proposal.

In order for the evaluation to be accomplished efficiently, at a minimum, the Conceptual Plans, included in the Technical Proposal Appendix, shall be prepared as described below.

4. Provide Conceptual Plans for the following:

- a. Conceptual Plans showing the mainline typical section(s) in the widening portion of the Project including pavement material selected.
- b. Conceptual plans including cross sections showing the proposed clear zone and control of access limits. The plan should provide enough detail to illustrate the proposed typical limits as well as the proposed limits in areas constrained by obstacles, environmental issues, or right-of-way. Where the full clear zone is not proposed, identify the constraints. The plan should

include proposed locations of median and sideline barriers as well as the proposed barrier types (i.e. cable, guardrail, concrete, etc.) at those locations.

- c. Conceptual Plans showing the development and reduction/merging of the new lanes at each end of the widened section of I-77. Conceptual Plans showing the new lanes interacting with the SC 277 Interchange and the termination of the northbound SC 277 onramps. Conceptual Plans showing improvements to I-77 acceleration/deceleration lanes at onramps and off-ramps within the widening sections. At a minimum, the plans should include proposed taper lengths and pavement markings.
5. Provide Conceptual Maintenance of Traffic Plans depicting the number of construction stages and a staging narrative within those plans to include duration of each stage. The plan scale and detail should be appropriate for demonstrating transitions, directional flow, and all items below.
- a. the Team's plan for access to the median work zone (ingress and egress) including access spacing
 - b. the Team's plan for maintaining ramp traffic
 - c. the Team's plan for notifying the traveling public of upcoming stages
 - d. the Team's plan for maintaining I-77 and US 21 mainline and ramp traffic while replacing the approach transitional slabs on the southbound I-77 bridge
6. Conceptual bridge plans for the mainline I-77 bridges which shall consist of:
- a. Plan and profile of each bridge showing horizontal and vertical clearances (not required for US 21 overpass)
 - b. Superstructure cross sections and substructure elevations showing pertinent structural elements and dimensions (not required for US 21 overpass)
 - c. Construction staging plan for bridge and approach slab work including dimensions of temporary roadway widths both on the bridges and, where applicable, on the roadway beneath the bridges
 - d. Horizontal and vertical plan for formwork/falsework
 - e. Bridge construction access plan showing areas used to access the bridge work and showing proposed equipment and material handling locations and staging

Note: Drawings and plans requested as part of the Technical Proposal or included by the Proposer to help explain commitments shall not count against the specified page limit and can be included in the Appendix.

B. Cost Proposal

PROPOSERS shall complete the Cost Proposal Bid Form provided at the end of this document. The Cost Proposal Bid Form shall be sealed in a separate envelope and delivered as part of the Cost Proposal per the Milestone Schedule.

C. Confidentiality of Proposals

PROPOSER shall specifically mark any elements that are deemed confidential, or proprietary. All markings must be conspicuous; use color, bold, underlining, or some other method in order to conspicuously distinguish the mark from the other text. Do not mark the entire proposal as confidential or proprietary. **In the Technical Proposal appendix, PROPOSER shall include a list of page numbers that contain confidential and/or proprietary information. Failure to include this list in the Technical Proposal appendix waives the confidentiality protection and subjects the information to disclosure in accordance with the law.** In determining whether to release documents, the SCDOT will rely on PROPOSER's list of page numbers and PROPOSER's marking of each page or portions of pages of documents, as required by these instructions, as being either "Confidential" or "Trade Secret". PROPOSER shall be prepared upon request to provide justification of why such materials shall not be disclosed under the South Carolina Freedom of Information Act, Section 30-4-10, et seq., South Carolina Code of Laws (1976) as amended. Proposals will be kept confidential and will not be disclosed, except as may be required by law.

D. Noncollusion and Equal Employment Opportunity Certification

PROPOSERS shall certify that they have not participated in any collusion or otherwise taken any action in restraint of free competitive bidding in connection with the submission of this proposal on this Project. Proposal submitted without the non-collusion certification may be deemed non-responsive. The non-collusion certification form provided as part of this document shall be submitted as part of the Technical proposal and will not count against the specified page limit.

PROPOSERS shall complete the Equal Employment Opportunity (EEO) Performance Certification form provided as part of this document. Proposal submitted without the EEO certification may be deemed non-responsive. The EEO certification form shall be submitted as part of the Technical proposal and will not count against the specified page limit.

V. EVALUATION OF PROPOSALS

A. Proposal Review Committee

A Proposal Review Committee ("Committee") will be appointed by SCDOT to review the Proposals. The voting members will be comprised of SCDOT employees. In addition, SCDOT will assemble a group of non-voting resource members having expertise in the various disciplines required by the Project including the Federal Highway Administration.

B. Proposal Review

The Committee will review the Proposals and determine whether each Proposal is responsive. Responsive Proposals will be accepted by the Committee for evaluation. PROPOSERS that submit a non-responsive proposal will be sent a letter with a detailed explanation as to the reasons for determining non-responsiveness. Any nonresponsive unopened Cost Proposal(s) will be retained by SCDOT until either contract execution or RFP cancellation and then returned to the nonresponsive PROPOSER(s). One (1) original copy of the nonresponsive Technical

Proposal(s) will be retained by SCDOT and remaining copies will be returned if requested by PROPOSER. Reasons for determining a proposal to be non-responsive may result from, but are not limited to, the following: failure to provide all information requested in the proposal, failure to conform to the material requirements of the RFP, conflict of interests, conditional proposals, failure to provide complete and honest information, failure to complete the Cost Proposal Bid Form correctly, or failure to submit the EEO certification. Responsive Proposals will be evaluated and scored by the Committee as explained in Article V.C. below. Proposals which impose conditions that modify material requirements of the RFP may be rejected as non-responsive. Proposers will not be given an opportunity to correct any material nonconformity. Any deficiency resulting from a minor informality may be clarified or waived at the sole discretion of the SCDOT.

C. Technical Evaluation

All Proposals will be evaluated for technical merit prior to opening the Cost Proposals. The Committee will determine responsiveness of the Technical Proposal based on responses to all items requested in the RFP and conformance with the requirements of RFP Attachments A and B. For the items that have quality credit points associated with them, the Committee will utilize the table below entitled “Quality Credit Percentage for Technical Proposals” to assign a quality credit percentage to each Proposal based on the PROPOSER’s overall quality score. The quality score will reflect commitments made by the PROPOSER in the Commitment Matrix Form that exceed Project requirements identified in the RFP and that are deemed of value to the Project by the Committee. The maximum quality credit percentage for this Project will be 5%.

Quality Credit Percentage for Technical Proposals

Quality Points	Quality Credit (%)
100	5.0
90	4.5
80	4.0
70	3.5
60	3.0
50	2.5
40	2.0
30	1.5
20	1.0
10	0.5
0	0.0

D. Presentations

PROPOSERS who have submitted responsive Technical Proposals may be invited by the Committee to make a presentation. The presentation, if required, will allow the PROPOSERS an opportunity to further explain any aspect of their Technical Proposals. The Committee may address questions to the PROPOSER after the presentation.

E. Clarifications

SCDOT, at its sole discretion, shall have the right to seek clarifications from any PROPOSER to fully understand information contained in their responses to the RFP. Clarifications mean a written or oral exchange of information which takes place after the receipt of proposals when award without discussions is contemplated. The purpose of clarifications is to address minor or clerical revisions in a proposal.

F. Opening of Cost Proposals/Bid Opening Meeting

All Technical Proposals will be evaluated for responsiveness based on those items requested in this RFP. Those Technical Proposals deemed non-responsive will be handled according to Article V., Paragraph B. As detailed above, those Technical Proposals deemed responsive will be scored according to the information provided in this RFP. Based upon that score, a quality credit percentage will be applied to the PROPOSER's Cost Proposal, in accordance with the table shown above. The quality credit percentage will be provided confidentially in a sealed envelope to each PROPOSER at the Opening of Cost Proposals/Bid Opening meeting as shown on the Milestones Schedule in Article VIII of this RFP.

Cost Proposals of PROPOSERS with responsive Technical Proposals will be opened at the meeting. The Total Bid amount shown on the Cost Proposal Bid Form and the Quality Credit Score for each respective PROPOSER will be entered into a spreadsheet and analyzed. Each Cost Proposal will be compared against the confidential SCDOT Engineer's Estimate.

If upon analysis, one or more of the Total Adjusted Bids is within an acceptable range of the Engineer's Estimate, all Total Bid Amounts (including A and B portions if applicable) and Quality Credit Scores for each PROPOSER will be read aloud and the proposals will be ranked based on the lowest Total Adjusted Bid.

If upon analysis, all of the Total Adjusted Bids exceed an acceptable range of the Engineer's Estimate, only the Total Bid Amounts (including the A and B portions if applicable) will be read and the Quality Credit Scores for each PROPOSER will remain confidential and be known only to each respective PROPOSER. The meeting will then adjourn so that SCDOT personnel may assess if either award outside the prescribed range is justified or if the SCDOT will hold discussions and may request a Best and Final Offer (BAFO) from all responsive PROPOSERS.

In the event that SCDOT elects NOT to proceed with a Best and Final Offer (BAFO), then SCDOT will schedule a date and time to publicly reiterate all Total Bids Amounts and read all Technical Scores.

SCDOT intends to award the contract to the PROPOSER with the lowest Total Adjusted Bid. However, the RFP may be cancelled after opening, but prior to the issuance of an award, when such action is determined in writing to clearly be in the best interest of the State. If the RFP is cancelled, Cost Proposals may be returned to the PROPOSERS and a new solicitation may be conducted for the Project.

G. Total Adjusted Bid Determination

The Adjusted Low Bid method will be utilized in determining the Total Bid to determine the lowest adjusted bid. Award of the Contract, if made, will be made to the responsible and qualified PROPOSER who submits the lowest Total Adjusted Bid. In the event that two or more PROPOSERS are determined to have the same lowest total adjusted bid, the award, if made, will be made to the PROPOSER with the highest quality credit score. The following formula will be used to evaluate the values given on the Cost Proposal Bid Form:

$$\text{Total Adjusted Bid} = A - [A \times \text{Quality Credit}] + B:$$

A Total Cost to Complete all work to be performed under the contract

B Project Construction Time Cost (B = b x dc)

b Construction time (b) is defined as calendar days from Notice to Proceed to Substantial Work Completion of the Project.

dc Daily cost associated with the Project as stipulated on the Cost Proposal Bid Form (\$4,000-\$10,000 per day)

Quality Credit is the assigned quality credit percentage as a result of the proposal's technical score; expressed as a decimal.

Example for Determining Total Adjusted Bid

Proposal	Quality Points	Quality Credit (%)	Cost Proposal (A)	Quality Value	Construction Time (b)	Total Adjusted Bid
A	100	5.0	\$100,000,000	5,000,000	1000	105,000,000
B	80	4.0	105,000,000	4,200,000	750	108,300,000
C	60	3.0	110,000,000	3,300,000	800	114,700,000
D	70	3.5	107,000,000	3,745,000	850	111,755,000

Note: In this example, Proposal A was determined to be the lowest total adjusted bid

VI. SELECTION OF CONTRACTOR

The Committee will present a report regarding their review of the proposals to SCDOT Deputy Secretary for Engineering and recommend selection of the PROPOSER with the lowest Total Adjusted Bid. Upon approval, SCDOT will offer a contract to the selected PROPOSER. *However, if the parties are unable to execute a contract, SCDOT may offer a contract to the PROPOSER with the next lowest Total Adjusted Bid.*

The Design-Build Agreement will be executed for the Total Cost to Complete as shown in the Cost Proposal Bid Form and the Project Construction Time will be the Total Number of

Calendar Days from the Notice to Proceed to Substantial Work Completion of the Project. Construction time for the Project shall be established as shown on the Cost Proposal Bid Form.

VII. GENERAL INFORMATION

- I. SCDOT reserves the right to terminate the evaluation of one or more of the proposals if it is determined to be in the best interest of the state to do so.
- II. SCDOT reserves the right, at its sole discretion, to either cancel this solicitation or to re-advertise in another public solicitation when it is in the best interest of the state to do so.
- III. SCDOT reserves the right to reject any and all proposals, or parts thereof, and/or to discontinue contract execution with any party at any time prior to final contract execution.
- IV. SCDOT assumes no liability and will not reimburse costs incurred by firms, whether selected or not, in developing proposals or in contract execution.
- V. SCDOT reserves the right to request or obtain additional information about any and all proposals. SCDOT may also issue addenda to the RFP, which will be posted on the website and emailed to all PROPOSERS' Points of Contacts.
- VI. SCDOT reserves the right to revise or amend the RFP, specifications and/or drawings, including changes to the date the proposal is due. Such changes, if any, will be announced by an addendum or addenda to this Request for Proposal. All information relating to this RFP, including pertinent changes/addendums and other applicable information will be posted on SCDOT's design build website www.SCDOT.org a minimum of ten (10) business days prior to the date set for receipt of proposals as set forth in the Milestone Schedule. If changes are made to the RFP within ten (10) days of the due date, Milestones may be adjusted accordingly. **PROPOSERS are strongly cautioned to check this site frequently to ensure they have the latest information.**
- VII. Receipt of an addendum by the PROPOSER must be acknowledged in the space provided on the Addendum Notice to Proposer Transmittal Form posted on the SCDOT Design Build website for this Project. PROPOSERS shall submit the signed Notice with its Technical Proposal response to this RFP. Failure to acknowledge an addendum may result in rejection of the proposal. Explanations or instructions given in a form other than an addendum or ATC response letter shall not be binding.
- VIII. After award, if an unsuccessful PROPOSER would like to schedule a debriefing, PROPOSER shall submit a request within three (3) business days from the date the award notification is posted on the SCDOT Design Build website for this Project. Only written requests (emails are acceptable) for a debriefing will be scheduled.

Failure to request a debriefing within the three (3) business day period waives the opportunity for a debriefing.

- IX. All PROPOSERS must visibly mark as “CONFIDENTIAL” each part of their submission that they consider to contain proprietary information the release of which would constitute an unreasonable invasion of privacy. All unmarked pages will be subject to release in accordance with law. **In the Technical Proposal appendix, PROPOSER shall include a list of page numbers that contain confidential and/or proprietary information. Failure to include this list in the Technical Proposal appendix waives the confidentiality protection and subjects the information to disclosure in accordance with the law.** PROPOSER should be prepared, upon request, to provide justification of why such materials should not be disclosed under the South Carolina Freedom of Information Act, S.C. Code Section 30-4-10, et seq.
- X. PROPOSER shall be held responsible for the validity of all information supplied in its proposal, including that provided by potential subcontractors. Should subsequent investigation disclose that the facts and conditions were not as stated, the proposal may be rejected or contract terminated for default if after award, in addition to any other remedy available under the contract or by law.
- XI. PROPOSER, by submitting a proposal, represents that it has read and understands the RFP, its exhibits, attachments and addendums, and that its proposal is made in compliance with the criteria of the RFP. PROPOSERS are expected to examine the RFP, its exhibits, attachments and addendums thoroughly and should request an explanation of any ambiguities, discrepancies, errors, omissions, or conflicting statements therein. Failure to do so will be at the PROPOSER's risk. PROPOSER assumes responsibility for any patent ambiguity in the RFP, its exhibits, attachments and addendums that PROPOSER does not bring to SCDOT's attention.
- XII. No proposal guaranty in the form of a Bid Bond is required for this procurement.
- XIII. Proposal Acceptance Period - By submitting a proposal, PROPOSER agrees to hold the proposal offer available for acceptance a minimum of ninety (90) calendar days after the Bid Opening date.
- XIV. A **business day** is hereby defined as a day in which SCDOT Headquarters is open for business.

VIII. MILESTONES

Provide RFP for Industry Review to Selected Short-list PROPOSERS	Wednesday, May 27, 2015
Deadline Clarifications/Comments to be submitted by PROPOSERS	Wednesday, June 10, 2015
First Confidential One-on-One meetings with PROPOSERS for RFP for Industry Review Clarifications/Comments	Tuesday, June 23, 2015
Issue Final RFP	Thursday, July 23, 2015
Preliminary ATC Submittals (Start)	Thursday, July 23, 2015
Confidential RFP Questions and Preliminary ATC (finish) to be submitted by PROPOSERS	Wednesday, August 5, 2015
Second Confidential RFP and ATC One-on-One meetings with PROPOSERS	Wednesday, August 12, 2015
Begin Formal ATC Process	Wednesday, August 12, 2015
All Formal ATC's SHALL be submitted prior to	4:00 PM EDT on Thursday, August 27, 2015
Submittal of Proposals prior to	4:00 PM EDT on Wednesday, September 30, 2015
Bid Opening(with team representatives present)	Thursday, October 29, 2015 at 2:00 PM EDT at SCDOT HQ Room 306
Notification of Selection	November 2015
Award/Contract Execution	SCDOT Commission Meeting January 2016

IX. COST PROPOSAL BID FORM

I-77 Widening & Rehab from MM 15 to MM 27 Richland County

CONTRACTOR: _____

ADDRESS: _____

Provide full Project scope as described in Attachment A.

TOTAL COST TO COMPLETE (A)= _____

dc (Daily Cost of Project) = \$10,000

CONSTRUCTION TIME (b) IS DEFINED AS CALENDAR DAYS FROM NOTICE TO PROCEED TO SUBSTANTIAL WORK COMPLETION OF THE PROJECT.

Construction Time (Calendar Days)(b)= _____

Project Construction Time Cost (B) = _____

TOTAL BID (A+B) = _____

No conditional Bids will be accepted. SCDOT reserves the right to delete any or all conditions placed on the Total Cost to Complete, and/or reserves the right to reject any Bid that is conditional or contains additions not called for in the plans and specifications.

Signature

Date

Printed Name

X. NON-COLLUSION CERTIFICATION

NON-COLLUSION CERTIFICATION

Project ID: P027002

IN ACCORDANCE WITH THE PROVISIONS OF S.C. CODE ANN. §§ 39-3-10 ET.SEQ., 39-5-10 ET. SEQ., 15 U.S.C. §45; 23 C.F.R. §635.112(F); AND 28 U.S.C. §1746, I HEREBY ACKNOWLEDGE THAT I AM AN OFFICER OF THE PROPOSER FIRM AND, UNDER PENALTY OF PERJURY UNDER THE LAWS OF THE UNITED STATES AND SOUTH CAROLINA, DECLARE, BY MY CERTIFICATION BELOW, THAT THE FOLLOWING IS TRUE AND CORRECT, AND FURTHER, THAT THIS FIRM, ASSOCIATION OR CORPORATION HAS NOT, EITHER DIRECTLY OR INDIRECTLY, ENTERED INTO ANY AGREEMENT, PARTICIPATED IN ANY COLLUSION, OR OTHERWISE TAKEN ANY ACTION IN RESTRAINT OF FREE COMPETITIVE BIDDING IN CONNECTION WITH THE SUBMISSION OF A BID PROPOSAL ON THE ABOVE REFERENCED PROJECT.

BY CHECKING THIS BOX , I CERTIFY THAT I HAVE READ, UNDERSTAND, ACCEPT, AND ACKNOWLEDGE ALL OF THE ABOVE STATEMENTS.

Executed on _____
(Date)

Signed: _____
(Officer/Proposer)

(Title)

(Address)

XI. EQUAL EMPLOYMENT OPPORTUNITY CERTIFICATION

(COMPLETE THIS SECTION FOR FEDERAL PROJECTS ONLY)

EQUAL EMPLOYMENT OPPORTUNITY PERFORMANCE

Select the Certification that applies to the PROPOSER:

Certification (1) **or** **Certification (2)**

Select the appropriate responses in the applicable Certification:

Certification (1): Pursuant to 41 C.F.R. §60-1.7(b)(1), Previous Equal Employment Opportunity Performance Certification, as the Prospective Prime Contractor, **I HEREBY CERTIFY THAT I:**

- (a) **(HAVE / HAVE NOT)** developed and filed an Affirmative Action Program pursuant to 41 C.F.R. §60-2;
- (b) **(HAVE / HAVE NOT)** participated in a previous contract or subcontract subject to the equal opportunity clause;
- (c) **(HAVE / HAVE NOT)** filed with the Joint Reporting Committee, the Director of Office of Federal Contract Compliance, or the Equal Employment Opportunity Commission, all reports due under the applicable filing requirements,

OR

Certification (2): **I, HEREBY CERTIFY** that as the Prospective Prime Contractor submitting this Proposal, **(CLAIM / DO NOT CLAIM)** exemption from the submission of the Standard Form 100 (EEO-1) due to the fact that it employs a total of less than fifty (50) employees under C.F.R. §60-1.7, or qualifies for an exempted status under 41 C.F.R. §60-1.5.

I FURTHER CERTIFY that the above Certification will be made part of any Subcontract Agreement involved with this Project.

Executed on _____, 20__ Signed: _____

(Officer/Proposer)

(Title)

(Company)

(Address)

SEAL

XII. STIPEND ACKNOWLEDGEMENT FORM

Stipend Acknowledgement Form

I-77 Widening & Rehab from MM 15 to MM 27 Richland County

PROPOSER: _____

ADDRESS: _____

The undersigned PROPOSER, hereby:

Waives the stipend for this Project.

Accepts the stipend for this Project.

By accepting the stipend for this Project, PROPOSER agrees:

- 1) to execute and include the Stipend Agreement in Article XIII of the RFP with their RFP response;
- 2) SCDOT will pay the stipend to each eligible unsuccessful PROPOSER, who has signed a Stipend Agreement, within ninety (90) days after execution of the contract or the decision not to award a contract;
- 3) to transfer all rights to its Work Product used to develop the proposal as of the date of this acknowledgement. "Work Product" means all submittals, including ATCs, ideas, innovations, solutions, methods, processes, design concepts, materials, electronic files, marked up drawings, cross sections, quantity lists and intellectual property, made by PROPOSER during the RFP process, including the proposal, exchange of information during the pre-proposal and post-proposal period.

Date

PROPOSER

Print Name

XIII. STIPEND AGREEMENT

STIPEND AGREEMENT

Project ID: P027002

I-77 Widening & Rehab from MM 15 to MM 27 Richland County

THIS STIPEND AGREEMENT (the "Agreement") is made and entered into as of the ___ day of _____, 20_, by and between the SOUTH CAROLINA DEPARTMENT OF TRANSPORTATION (hereinafter "SCDOT"), and _____ ("PROPOSER"), with reference to the following facts:

SCDOT issued a Request for Proposal ("RFP") for design and construction of the above-referenced Design-Build Project ("Project"), pursuant to procurement authority granted in Section 57-5-1625 of the S.C. Code of Laws, 1976, as amended. The RFP provided for payment of stipends as provided herein.

NOW, THEREFORE, PROPOSER hereby agrees as follows:

1. Work Product.

1.1 PROPOSER shall prepare and submit a responsible and responsive technical and cost proposal that conforms in all material respects to the requirements and provisions of the RFP, as determined by SCDOT, and are timely received by SCDOT in accordance with the RFP Milestone Schedule.

1.2 By signing this Stipend Agreement, PROPOSER agrees to transfer ownership to SCDOT of the electronic copy and hard copy of all Work Product used to develop the proposal. The Work Product (as defined below) shall become the property of SCDOT without restriction or limitation on its use, without further compensation or consideration, and can be used in connection with this Project or any future projects by SCDOT. Neither PROPOSER nor any of its team members shall copyright any of the material developed under this Agreement.

1.3 The term "Work Product" shall mean all material, electronic files, marked up drawings, cross sections, quantity lists, submittals, alternative technical concepts (ATC), ideas, innovations, solutions, methods, processes, design concepts, and intellectual property, made by or produced for PROPOSER in the development and submission of the technical and price proposals, including exchanges of information during the pre-proposal and post-proposal period.

2. Compensation and Payment.

2.1 A stipend to PROPOSER for the Work Product described herein shall be \$40,000.00 and is payable on condition that PROPOSER (1) submitted a responsible and responsive technical and cost proposal to the RFP which is not selected for award of this Project, or (2) was awarded the Contract but the Contract was terminated by SCDOT at SCDOT's convenience after the Submittal of Proposal Date (See Final RFP Milestone schedule) but prior to the Notice to Proceed #1. Responsibility and responsiveness of the proposal will be determined by SCDOT as a condition of payment.

2.2 SCDOT will pay the stipend to PROPOSER under the following conditions:

(a) Within ninety (90) days after execution of the contract or the decision not to award a contract, SCDOT will pay the stipend to the unsuccessful PROPOSER meeting the criteria of Section 2.1, provided that the PROPOSER submitted a signed a Stipend Agreement with its response to the RFP.

(b) If the procurement is suspended or cancelled prior to the Proposal Due Date (see FINAL RFP Milestone schedule), no stipend will be paid to PROPOSER.

(c) After the submittal of proposals, but prior to award, if the procurement is cancelled, all PROPOSERS that provide a responsive technical and cost proposal to the final RFP and submitted a signed Stipend Agreement with their RFP shall receive the stipend

(d) In the event of a Best and Final Offer, only one stipend will be paid.

(e) No stipends will be paid for submitting RFQ responses.

2.3 Acceptance by the PROPOSER of payment of the stipend amount from SCDOT shall constitute a waiver by PROPOSER of any and all right, equitable or otherwise, to bring any claim in connection with this procurement, procurement process, award of the Contract, or cancellation of this procurement.

2.4 The PROPOSER awarded the contract shall be not eligible to receive a stipend.

2.5 If PROPOSER elects to waive payment of the stipend, SCDOT will not use the ideas or information contained in that PROPOSER's proposal for this Project. However, the PROPOSER's proposal will be subject to the South Carolina Freedom of Information Act.

REQUEST FOR PROPOSALS

I-77 Widening & Rehab from MM 15 to MM 27, Richland County, South Carolina
Project ID P027002

3. Indemnities.

3.1 Subject to the limitations contained in Section 3.2, PROPOSER shall indemnify, protect and hold harmless SCDOT and its directors, officers, employees and contractors from, and PROPOSER shall defend at its own expense, all claims, costs, expenses, liabilities, demands, or suits at law or equity arising in whole or in part from the negligence or willful misconduct of PROPOSER or any of its agents, officers, employees, representatives or subcontractors or breach of any of PROPOSER’s obligations under this Agreement.

3.2 This indemnity shall not apply with respect to any claims, demands or suits arising from use of the Work Product by SCDOT.

4. Compliance With Laws.

4.1 PROPOSER shall comply with all federal, state, and local laws, ordinances, rules, and regulations applicable to the work performed or paid for under this Agreement and covenants and agrees that it and its employees shall be bound by the standards of conduct provided in applicable laws, ordinances, rules, and regulations as they relate to work performed under this Agreement. PROPOSER agrees to incorporate the provisions of this paragraph in any subcontract into which it might enter with reference to the work performed pursuant to this Agreement.

4.2 The PROPOSER agrees (a) not to discriminate in any manner against an employee or applicant for employment because of race, color, religion, creed, age, sex, marital status, national origin, ancestry or disability of a qualified individual with a disability; (b) to include a provision similar to that contained in subsection (a) in any subcontract; and (c) to post and to cause subcontractors to post in conspicuous places available to employees and applicants for employment, notices setting forth the substance of this clause.

5. Assignment.

PROPOSER shall not assign this Agreement without SCDOT’s prior written consent. Any assignment of this Agreement without such consent shall be null and void.

6. Miscellaneous.

6.1 PROPOSER and SCDOT agree that PROPOSER, its team members, and their respective employees are not agents of SCDOT as a result of this Agreement.

6.2 This Agreement, together with the RFP, as amended from time to time, the provisions of which are incorporated herein by reference, embodies the entire agreement of the parties. There are no promises, terms, conditions, or obligations other than those contained herein or in the RFP, and this Agreement shall supersede all previous communications, representation, or agreements, either verbal or written, between the parties hereto.

6.3 It is understood and agreed by the parties hereto that if any part, term, or provision of this Agreement is by the courts held to be illegal or in conflict with any law of the State of South Carolina, the validity of the remaining portions or provisions shall not be affected, and the rights and obligations of the parties shall be construed and enforced as if the Agreement did not contain the particular part, term, or provisions to be invalid.

6.4 This Agreement shall be governed by and construed in accordance with the laws of the State of South Carolina.

IN WITNESS WHEREOF, the parties have executed this Agreement as of the date first written above.

Witness:

SOUTH CAROLINA DEPARTMENT
OF TRANSPORTATION

By: _____
Ladd Gibson, P.E.
Design Build Engineer

Recommended:

Jae Mattox, P.E.
Program Manager

PROPOSER

Name of PROPOSER

Witness:

By: _____
Its: _____

XIV. COMMITMENT MATRIX FORM

Commitment Number	RFP Question Number	Proposal Page Number	Commitment Description
1			
2			
3			
4			

AGREEMENT

AGREEMENT
FOR THE DESIGN & CONSTRUCTION
of
Interstate 77 Widening and Rehabilitation
from MM 15 to MM 27

Richland County, South Carolina

A DESIGN-BUILD PROJECT

BETWEEN
SOUTH CAROLINA DEPARTMENT OF TRANSPORTATION
AND

_____ day of _____, 2014

Project ID P027002

TABLE OF CONTENTS		Page Number
LIST OF EXHIBITS.....		4
I.	CONTRACT DOCUMENTS	6
II.	PROJECT SCOPE	6
	A. Scope of Work	6
	B. Design and Construction Responsibilities	6
	C. Design Criteria	7
	D. Design Review	8
	E. Maintenance of Traffic	8
	F. Ownership of Documents	9
	G. Construction Criteria.....	9
	H. Project Management	10
	I. Control of the Work	10
	J. Contract Deliverables.....	11
III.	CONTRACT PRICE/CONTRACT PAYMENTS	12
	A. Contract Price.....	12
	B. Contract Price Adjustments	12
	C. Contract Payments	14
	D. Retainage.....	17
IV.	CONTRACT TIME	17
	A. Project Schedule.....	17
	B. Contract Time Adjustments	20
	C. Owner’s Right to Stop Work	20
	D. Liquidated Damages	21
V.	QUALITY ASSURANCE PROGRAM	21
	A. CONTRACTOR’s Responsibilities	21
	B. SCDOT Responsibilities.....	23
	C. CONTRACTOR’s Obligation	24
VI.	INSURANCE AND BONDING.....	24
	A. Insurance	24
	B. Bonding.....	27
VII.	UTILITIES AND RAILROAD COORDINATION.....	28
VIII.	RIGHT OF WAY ACQUISITION.....	31

- A. Right of Way Services 31
- B. Acquisition of Right-of-Way 34
- IX. PERMITS..... 35
- X. ENVIRONMENTAL COMPLIANCE..... 36
 - A. Compliance with Environmental Commitments..... 36
 - B. Preconstruction / Partnering Conference(s)..... 37
 - C. Protection of Archeological and Paleontological Remains and Materials..... 37
 - D. Community and Public Relations Plan 37
- XI. HAZARDOUS MATERIALS 38
- XII. DEMOLITION, REMOVAL & DISPOSAL OF STRUCTURES..... 39
- XIII. DIFFERING SITE CONDITIONS..... 39
- XIV. FORCE MAJEURE 39
- XV. WARRANTY 40
- XVI. INDEMNITY 41
- XVII. TERMINATION AND CANCELLATION 41
- XVIII. DISADVANTAGED BUSINESS ENTERPRISES 43
- XIX. ON-THE-JOB TRAINING REQUIREMENTS 44
- XX. RECORD RETENTION..... 44
- XXI. AS-BUILTS 44
- XXII. ESCROW PROPOSAL DOCUMENTS..... 46
 - A. Scope and Purpose 46
 - B. Proposal Documentation..... 46
 - C. Submittal of Proposal Documentation 46
 - D. Alternative Delivery Method 46
 - E. Affidavit..... 47
 - F. Verification 47
 - G. Duration and Use 47
 - H. Refusal or Failure to Provide Proposal Documentation 48
 - I. Confidentiality of Bid Documentation..... 48
 - J. Cost and Escrow Instructions..... 48
 - K. Escrow Agreement..... 48
 - L. Payment..... 48

XXIII. DISPUTE RESOLUTION 48
XXIV. SCDOT’S AGENT 49
XXV. ASSIGNABILITY 49
XXVI. GENERAL PROVISIONS 49
CERTIFICATION OF CONTRACTOR 52
CERTIFICATION OF DEPARTMENT 53

LIST OF EXHIBITS

- 1. Cost Proposal Bid Form
- 2. Schedule of Values
- 3. Scope of Work
- 4. Project Design Criteria
 - 4a. Roadway
 - 4b. Structures
 - 4c. Pavement
 - 4d. Traffic
 - Part 1 – Signing and Pavement Markings
 - Part 2 – Work Zone Traffic Control
 - Part 3 – Traffic Signals
 - Part 4 – Intelligent Traffic System
 - 4e. Hydraulic
 - 4f. Geotechnical
 - 4g. Environmental
- 5. Special Provisions
- 6. Federal Aid Provisions ~~Project Supplemental Specifications~~
- 7. Escrow Proposal Documents
- 8. Railroad Information

WHEREAS, the South Carolina Department of Transportation, as an agency of the State of South Carolina, wishes to improve the safety and operation of the state highway system by widening and rehabilitating Interstate 77 from milemarker 15 to milemarker 27 in Richland County (hereinafter referred to as “the Project”); and

WHEREAS, the South Carolina Department of Transportation, as a servant of the people of the State of South Carolina, wishes to see this strategic project completed; and

WHEREAS, limitations imposed by traditional methods of designing, and constructing highways would mean that the Project could be completed only after an unacceptable delay; and

WHEREAS, the South Carolina Department of Transportation, working with the Federal Highway Administration (FHWA), has devised an innovative plan to allow the commencement and completion of the Project in a timely and cost-effective manner; and

WHEREAS, pursuant to Section 57-5-1625 SC Code of Law, the South Carolina Department of Transportation desires to award a highway construction contract using a Design / Build procedure; and

WHEREAS, after a competitive process, CONTRACTOR has been selected to participate in this venture by designing and building the Project; and

WHEREAS, the South Carolina Department of Transportation wishes to avail itself of and rely on CONTRACTOR’s expertise and proven track record in designing and constructing such projects, on time and within budget; and

WHEREAS, CONTRACTOR wishes to provide that expertise and to participate in this venture for the good of the people of the State of South Carolina;

NOW THEREFORE, this Agreement is executed and made, effective as of the Effective Date as defined herein, between the SOUTH CAROLINA DEPARTMENT OF TRANSPORTATION (“SCDOT”) and _____ (“CONTRACTOR”). In consideration of the covenants hereinafter set forth, the parties hereto mutually agree as follows:

I. CONTRACT DOCUMENTS

The Contract shall be composed of this Agreement and all exhibits, SCDOT's Request for Proposals and all attachments, Request for Qualifications and all attachments, CONTRACTOR's Proposal and all attachments, and CONTRACTOR'S Qualifications and all attachments. In case of conflict, the order of precedence of the Contract documents shall be: (1) this Agreement; (2) Agreement Exhibits; (3) SCDOT Request for Proposals (RFP) document and Project Information; (4) CONTRACTOR's Proposal and attachments; and (5) SCDOT Request for Qualifications (RFQ) and CONTRACTOR's response. In the event of a conflict between the Project Criteria, Special Provisions and Supplemental Specifications identified in the Agreement Exhibits, the order of precedence shall be (1) the Project Criteria; (2) Special Provisions, and (3) Supplemental Specifications and Forms.

II. PROJECT SCOPE

A. Scope of Work

CONTRACTOR shall furnish all services, labor, materials, equipment, supplies, tools, transportation, and coordination required to perform all design, preliminary engineering, surveying, geotechnical services, scheduling, permitting, right of way services, procurement, construction, utility coordination, demolition, material disposal and any other services necessary to perform the Project as defined in the Project Scope of Work made a part hereof as **EXHIBIT 3**.

B. Design and Construction Responsibilities

1. CONTRACTOR, consistent with applicable state licensing laws, shall provide, through qualified South Carolina licensed design professionals employed by CONTRACTOR or procured from qualified, independent South Carolina licensed design consultants, the necessary design work, including, but not limited to, surveys, right of way services, roadway design, maintenance of traffic, geotechnical exploration and design, hydraulic analyses, storm water management, erosion control, superstructure design, and foundation and substructure design including seismic analyses for the preparation of the required drawings, specifications and other design submittals to permit CONTRACTOR to complete the work in accordance with the Contract.

2. CONTRACTOR shall provide through itself or subcontractors the necessary supervision, labor, inspection, testing, material, equipment, machinery, temporary utilities and other temporary facilities to permit performance of all demolition, earthwork, drainage, foundation work, maintenance of traffic, roadway work, structural work, excavation, erosion and sediment control work, field layout work, construction management and inspection, utility coordination and relocation, railroad coordination, CONTRACTOR quality control, and all other work necessary to complete construction of the Project in accordance with the Contract. CONTRACTOR shall perform all design and construction activities efficiently and with the requisite expertise, skill and competence to satisfy the requirements of the Contract. CONTRACTOR at all times shall exercise control over the means, methods, sequences and

techniques of construction. CONTRACTOR's operations and construction methods shall comply with all applicable federal, state and local regulations with regard to worker safety, protection and health and protection of the environment and applicable permit requirements.

3. CONTRACTOR shall design and construct the project in such a manner that the construction limits are contained within the approved environmental footprint to the extent possible. Where new right of way is required to construct the Project, the CONTRACTOR shall design and construct the Project so as to minimize the additional rights of way needed. The acquisition of rights of way, including both cost and services to acquire, shall be the responsibility of the CONTRACTOR and shall be done in accordance with Article VIII of this Agreement. CONTRACTOR shall furnish the SCDOT a copy of any agreements for the use of additional properties not acquired as right of way that are used in conjunction with the construction of this Project. CONTRACTOR shall abide by the provisions of all applicable environmental permits, any conditions of individual right of way agreements, and all environmental commitments. The CONTRACTOR shall sign the Contractor Certification Form and this agreement will be made part of the contract.

4. It shall be the responsibility of CONTRACTOR to determine and comply with all applicable federal, state, and local laws in connection with the services set forth in this Contract. This obligation shall include, but not be limited to, procurement of all permits and licenses not obtained by SCDOT provided, however, that with respect to any permit or licenses that must be obtained in the name of SCDOT, CONTRACTOR shall perform all functions within its power to obtain the permit, including mitigation, and SCDOT will fully cooperate in this effort and perform any functions that must be performed by SCDOT. CONTRACTOR shall be responsible for payment of all charges, fees, and taxes, and for providing all notices necessary and incident to the performance of the Project as of the Effective Date of this Agreement. The Contract Price shall include fees related to the above obligations and if any fees are waived by the regulatory or governmental entity, then the amount of the fee waived shall be deducted from the Contract Price.

C. Design Criteria

It shall be the responsibility of CONTRACTOR to design all aspects of the Project in accordance with the contract documents. For the Project, CONTRACTOR shall provide a completed set of construction plans signed and sealed by a licensed professional engineer in South Carolina. CONTRACTOR shall be fully responsible for the accuracy of the design and compliance with specifications, standards and Project Criteria.

D. Design Review

1. Within thirty (30) days prior to Notice to Proceed, CONTRACTOR, CONTRACTOR'S design consultant, subcontractors, suppliers and SCDOT shall meet to establish the sequencing procedures and schedule for submitting design plans for SCDOT's review. Within ten business (10) days after this meeting, CONTRACTOR shall provide a Design Submittal Procedures and Schedule acceptable to SCDOT. CONTRACTOR, CONTRACTOR'S design consultant, subcontractors and suppliers shall not submit any design work until the Design Submittal Procedures and Schedule is approved by SCDOT. The Design Submittal Procedures and Schedule will serve as the basis for reviewing the design and construction plans. The Design Submittal Procedures and Schedule shall be updated as requested by SCDOT

2. CONTRACTOR shall provide plans to SCDOT fifteen (15) SCDOT business days prior to commencement of the next phase of work, in formats designated by SCDOT, so that SCDOT will have an opportunity to review the plans prior to commencement of construction activities. The fifteen (15) business day review period will begin the first SCDOT business day after the submittal. If more than one package is submitted within a five (5) business day period, an additional five (5) business days per submittal package will be allowed for the reviews. Plans shall be submitted with all other reports and documents as defined in **EXHIBIT 4**. SCDOT will have the right, but not the obligation, to review and comment upon the plans. CONTRACTOR shall respond to SCDOT review comments in written form within five (5) business days. SCDOT will then status CONTRACTOR's comments within five (5) business days. SCDOT review comments shall be resolved prior to commencement of construction, demolition or disposal activities. This review and comment is fully discretionary, however no review or comment nor any failure to review or comment shall operate to absolve CONTRACTOR of its responsibility to design and build the Project in accordance with the contract or to shift responsibility to SCDOT.

E. Maintenance of Traffic

The SCDOT work zone mobility requirements found within the documents known as *Rule on Work Zone Safety and Mobility: The Policy for South Carolina Department of Transportation* and *Rule on Work Zone Safety and Mobility: Implementation, Maintenance, and Safety Guidelines* shall apply to this project. These requirements apply to the CONTRACTOR, all subcontractors, all SCDOT staff and designated representatives acting on behalf of the SCDOT performing duties with responsibilities relative to a work zone, including but not limited to planning, project development, design, construction, and maintenance.

The CONTRACTOR shall design, develop, implement and maintain a set of coordinated strategies to manage the work zone impacts of the project designated as the Transportation Management Plan. These strategies will include a Temporary Traffic Control plan, a Transportation Operations component, and a Public Information component. The Policy and the anticipated work zone impacts of the project shall determine the level of detail, content, and scope of the TMP. The primary component, the Temporary Traffic Control plan shall address traffic control and safety throughout and adjacent to the project site. A secondary component, the Transportation Operations plan, will address management of traffic operations in

the project site and all adjacent areas impacted by the project. The final component, the Public Information plan, addresses communications with the public and entities impacted by the project. The CONTRACTOR's Transportation Management Plan and its components shall comply with the requirements of this Agreement and subsequent Exhibits, Part 6 of the Manual on Uniform Traffic Control Devices (MUTCD) latest edition, and SCDOT policies, standard specifications and all addendums to the standard specifications, the typical traffic control standard drawings for road construction, and procedures.

F. Ownership of Documents

Drawings, specifications, test data, inspection reports, QC documents, daily diaries and any other documents, including those in electronic form, prepared by CONTRACTOR or CONTRACTOR's consultants are "Project Documents". CONTRACTOR and CONTRACTOR's consultants shall be the owner of the Project Documents. Upon the Effective Date of this Agreement, CONTRACTOR grants SCDOT a nonexclusive license to reproduce the Project Documents for the purposes of, but not limited to, promoting, using, maintaining, upgrading, or adding to the Project. Upon completion of the Project or upon default by CONTRACTOR, CONTRACTOR shall provide copies of all Project Documents to SCDOT in the format designated by SCDOT.

G. Construction Criteria

CONTRACTOR shall construct the Project in accordance with all applicable Federal, State, and local statutes and regulations. All construction shall be performed in accordance with the following criteria, which are incorporated herein by reference and made a part hereof. The construction criteria are intended to be complementary and to describe and provide for a complete work. Where the following construction criteria conflict, the order of precedence shall be as listed below:

1. **EXHIBIT 4** – Project Design Criteria
2. **EXHIBIT 5** – Special Provisions
3. SCDOT Standard Drawings, effective as of the release of the Final RFP
4. SCDOT Supplemental Specifications and Supplemental Technical Specifications, effective as of the release of the Final RFP
5. SCDOT Standard Specifications for Highway Construction, effective as of the release of the Final RFP
6. SCDOT Construction Manual, effective as of the release of the Final RFP
7. SCDOT Approval Sheets, Material Acceptance Policies and New Products Evaluation Summary (available on SCDOT internet website)

H. Project Management

1. CONTRACTOR shall be responsible for ensuring that the Project is constructed in conformance with the Contract, all referenced documents and specifications, and applicable laws and regulations.

2. CONTRACTOR shall provide project management services sufficient to supervise the activities of his own personnel and subcontractors. CONTRACTOR shall provide a sufficient number of persons on site, to the satisfaction of SCDOT, to provide for the construction management of the Project.

3. SCDOT will provide representatives assigned to the Project to monitor the construction and provide necessary coordination between SCDOT and CONTRACTOR. All costs for salary and equipment to maintain SCDOT employees will be provided by SCDOT at no expense to CONTRACTOR. SCDOT and Federal Highway Administration (FHWA) representatives will have full and complete access to the Project, the work in progress, the "Daily Diaries", and to other technical documents and project records associated with design, construction, demolition, material disposal, materials, quality control, materials installation, and testing. SCDOT representatives will receive reasonable notice of and have the opportunity to participate in any meetings that may be held concerning the Project or the relationship between CONTRACTOR and their consultants and subcontractors when such meetings are associated with technical matters, progress, or quality of the Project. As used in this paragraph, "notice" shall require actual written notice to SCDOT's Agent.

I. Control of the Work

1. CONTRACTOR shall determine the appropriate means, methods and scheduling necessary to complete the work timely and in accordance with all construction requirements. SCDOT and FHWA will have the right to review and inspect the work at any time.

2. If, at any time, SCDOT observes or has actual notice of any fault or defect in CONTRACTOR's performance of this Agreement, SCDOT will give CONTRACTOR prompt written notice reasonably detailing the nature of the fault or defect. SCDOT is not required to discover or to accept defective or faulty work. SCDOT's right to have defective or faulty work promptly corrected shall not be waived by any action of SCDOT.

3. SCDOT will have the authority to suspend the work, wholly or in part, for such periods, as SCDOT may deem necessary, due to CONTRACTOR's failure to meet the requirements of the Contract in the performance of the work.

4. No inspection, acceptance, payment, partial waiver, or any other action on the part of SCDOT will operate as a waiver of any portion of this Agreement or of any power reserved herein or any right to damages or other relief, including any warranty rights, except insofar as expressly waived by SCDOT in writing. SCDOT will not be precluded or estopped by anything contained herein from recovering from CONTRACTOR any overpayment as may be made to CONTRACTOR.

J. Contract Deliverables

CONTRACTOR shall submit deliverables including, but not limited to, the following as set forth in the CONTRACT.

1. Contract Deliverable Matrix
2. Schedule of Values (**EXHIBIT 2**)
3. Plans - Article II.D.2
4. Erosion Control and Spill Prevention Plan
5. Storm Water Pollutant Prevention Plan and signed Contractor Certification Form (SCDHEC 0437)
6. SCDHEC Notice of Intent (NOI) for Stormwater Discharges Covered Under SC NPDES Construction General Permit SCR160000)
7. Environmental Plan
8. USACE Section 404 Permit & Section 401 Certification
9. Wetland and Stream Mitigation
10. Transportation Management Plan
11. Crane Operator Documents
12. QC Plan
13. Community and Public Relations Plan, as specified in **Article X** and **EXHIBIT 5**
14. Drainage Notebooks for the Project in accordance with SCDOT's Requirements for Hydraulic Design
15. CPM Schedule per Article IV
16. EEO, DBE, and OJT Requirements, as specified in **Article XVIII, EXHIBIT 5, & EXHIBIT 6 Federal Aid Supplemental Specs**
17. Right-of-Way documents per Article VIII
18. Shop Plans and working drawings
19. Preliminary & Final Geotechnical Reports
20. All final electronic design files for the Project, as specified in **EXHIBIT 4**
21. Escrow Proposal Documents
22. CONTRACTOR's Materials Certification
23. As-Built Plans
24. Railroad Coordination Documents & Insurance Certificates per **EXHIBIT 8**

25. HAZMAT surveys for structures not already surveyed, SCDHEC Notice of Demolition for RCE Signature
26. Clearing and Grubbing Plan
27. Utility Coordination Reports, including Utility Agreements, and Supporting Documentation
28. Right of Way Plats and Monuments (per Preconstruction Advisory Memorandum #8)

III. CONTRACT PRICE/CONTRACT PAYMENTS

A. Contract Price

The “Contract Price” shall be \$_____. In consideration for the Contract Price, CONTRACTOR shall perform all of its responsibilities under the Contract. The Contract Price shall include all work identified in the Agreement and subsequent Exhibits and as identified in the Cost Proposal Bid Form – **EXHIBIT 1**.

B. Contract Price Adjustments

1. Allowable adjustments

The Contract Price may be adjusted to reflect the direct costs, plus an additional amount not to exceed 10% of the direct costs for the combined total of reasonable overhead* and profit, associated with any of the following:

- a) Amount added or deducted as the result of a “Change” or “Construction Change Directive”.
- b) Differing site condition as defined in Article XIII.
- c) Intentional or bad faith acts or omissions by SCDOT that unreasonably interfere with CONTRACTOR’s performance and cause delay of work on the critical path of the Project.
- d) Changes in legal requirements or regulations that are effective subsequent to the date of this Agreement.
- e) Discovery of hazardous materials as set forth in Article XI.
- f) Discovery of archeological or paleontological sites not previously identified as noted in Article X.
- g) Premium right-of-way costs and second appraisals as set forth in Article VIII. Only the actual premium right-of-way and actual second appraisal cost will be reimbursed. No additional amount for overhead, ~~and profit, bonds~~ **and insurance** will be considered for this item.

* Overhead: The operating expense of a business exclusive of direct cost labor and material.

Other than as provided above, the Contract Price shall not be increased for contract time adjustments or delay damages. Contract Price adjustments shall be documented by Supplemental Agreement signed by both parties and shall be reflected immediately in the Schedule of Values. No claim by the CONTRACTOR for an adjustment hereunder shall be allowed if notice is not given prior to final payment under this Agreement.

2. Changes

a) A “Change” shall be any deviation or variation from the Project Scope or the Project Criteria. No Change shall be implemented without the express written approval of SCDOT. A “Change” may be an “Additive Change” or a “Deductive Change”.

b) SCDOT may initiate a change by advising CONTRACTOR in writing of the change. As soon thereafter as practicable, CONTRACTOR shall prepare and forward to SCDOT an estimate of cost or savings, and the impact to the schedule resulting from the change. SCDOT will advise CONTRACTOR in writing of its approval or disapproval of the change via “Issue Paper”. If SCDOT approves the change, CONTRACTOR shall perform the Services as changed.

3. Construction Change Directive

A Construction Change Directive is a written order from SCDOT directing a change prior to agreement with CONTRACTOR on adjustment, if any, to the Contract Price or Contract Time. If a price for the work cannot be agreed upon, CONTRACTOR shall perform the work under Force Account Procedures as outlined in Section 109.5 of SCDOT's Standard Specifications.

4. Direct Costs

For the purpose of a Contract Price Adjustment, "Direct Costs" shall be defined as:

- a) Costs of labor, including social security, old age and unemployment insurance, fringe benefits required by agreement or custom, and workers' compensation insurance;
- b) Costs of materials, supplies, and equipment, including cost of transportation, whether incorporated or consumed;
- c) Actual costs of machinery and equipment owned by CONTRACTOR or any affiliated or related entity exclusive of hand tools;
- d) Actual costs paid for rental of machinery and equipment exclusive of hand tools;
- e) Costs of premiums for all bonds and insurance, permit fees, and sales, use or similar taxes;
- f) Additional costs of supervision and field office personnel directly attributable to the change or event; and
- g) Costs incurred or fees paid for design work related to the change or event.

C. Contract Payments

1. Schedule of Values

Prior to execution of this Agreement, CONTRACTOR shall provide a Schedule of Values acceptable to SCDOT and work may not start until the Schedule of Values is approved by SCDOT. The Schedule of Values will serve as the basis for cost loading of the CPM Schedule. The CPM schedule shall include sufficient information to provide for monetary and quantitative tracking of the work by SCDOT. Updates to the cost-loaded CPM schedule will serve as the basis for progress payments requested by and made to CONTRACTOR. If the Contract Price is adjusted, CONTRACTOR shall revise its Schedule of Values and the CPM Schedule to reflect the adjustment in the Contract Price. The revised Schedule of Values must be approved by SCDOT prior

to the time for the subsequent request for a progress payment otherwise no progress payments will be made. The Schedule of Values shall be incorporated herein as **EXHIBIT 2**. The Schedule of Values should include Lump Sum items that will serve as measurement and payment for any item referred to in this Contract as a “contract unit bid price” item.

2. Mobilization

Mobilization shall not exceed 5% of the Total Contract Cost as shown in the Schedule of Values. Mobilization will be paid in two (2) equal installments. The first will be paid in the progress payment immediately following Notice to Proceed, and the second will be paid at the start of construction.

3. Periodic Progress Payment Applications

No application for payment of the Contract Price shall be submitted until SCDOT gives a notice to proceed. Applications for payment of the Contract Price may be submitted once a month. Each application for payment of the Contract Price shall set forth, in accordance with the Schedule of Values and the cost-loaded CPM schedule, the percentage of all items comprising the work completed since CONTRACTOR’s immediately prior request for payment. The application for payment of the Contract Price may also request payment for equipment and materials not yet incorporated into the Project, provided that (i) SCDOT is satisfied that the equipment and materials are suitably stored at either the Project or another acceptable location, (ii) the equipment and materials are protected by suitable insurance and (iii) upon payment, SCDOT will receive title to the equipment and materials free and clear of all liens and encumbrances.

4. Periodic Progress Payments

SCDOT will review each application for payment. Upon approval by SCDOT of an application for payment, SCDOT will pay CONTRACTOR the undisputed percentage for the Project completed during the period covered by the application for payment. SCDOT will make each payment within twenty-one (21) days of the receipt of the corresponding Application for Payment. In the event of a dispute over the quality of work or percentage of the Project completed, SCDOT’s decision is controlling and final. Payment by SCDOT will not preclude or estop SCDOT from correcting any measurement, estimate, or certificate regarding the percentage completion of the Project, and future payments may be adjusted accordingly.

5. Prompt Payment of Subcontractors

a) Subject to the provisions on retainage provided in Paragraph (b) below, when a subcontractor has satisfactorily performed a work item of the subcontract, CONTRACTOR must pay the subcontractor for the work item within seven (7) calendar days of CONTRACTOR’s receipt of payment from SCDOT.

A subcontractor shall be considered to have "satisfactorily performed a work item of the subcontract" when SCDOT pays CONTRACTOR for that work item.

b) CONTRACTOR may withhold as retainage up to five (5%) percent of a subcontractor's payment until satisfactory completion of all work items of the subcontract. "Satisfactory completion of all work items of the subcontract" shall mean when SCDOT pays CONTRACTOR for the last work item of the subcontract. CONTRACTOR must release to the subcontractor any retainage withheld within seven (7) calendar days from the date CONTRACTOR receives payment from SCDOT for the last work item of the subcontract. For further information regarding Retainage, see Article III, paragraph D.

c) With each progress payment application, CONTRACTOR shall certify to SCDOT that the payment application is complete and that all subcontractors have been paid for work covered by previous applications.

d) Failure to comply with any of the above provisions shall result in one or more of the following sanctions: (1) no further payments to CONTRACTOR unless and until compliance is achieved; (2) CONTRACTOR being placed in default; and/or (3) CONTRACTOR being declared delinquent, such delinquency being subject to procedures and penalties provided in 108.8 of the Standard Specifications.

6. Withholding of Payment

SCDOT may withhold all or part of any payment under the Contract because for any of the reasons listed below. Any funds withheld will be released upon CONTRACTOR satisfactorily remedying the defect, fault, or failure and will be included in the next regularly schedule pay estimate. Payment will be subject to retainage if applicable.

a) Defective work not remedied. Any such withholding, however, shall not exceed two times the reasonable cost of remedying the defective work. Defective work shall be defined as work or material not conforming to the requirements of the Contract.

b) Reasonable evidence that the Work will not be Substantially Complete within the Contract Time as adjusted and that the unpaid balance of the Contract Price will not be adequate to cover Liquidated Damages for the actual unexcused delay;

c) Failure to comply with the prompt payment provision of this Contract;

d) Any fines or other charges to SCDOT due to CONTRACTOR's failure to comply with permit requirements or other regulations;

e) Notice of cancellation of insurance;

- f) Failure to submit updated and approved CPM or Schedule of Values;
- g) Violation of QC plan requirements;
- h) Failure to follow specifications or procedures required by the Contract;
- i) Failure to comply with DBE, On-The-Job training, or Pre-Employment Training provisions;
- j) Failure to provide adequate work zone traffic control;
- k) Failure to provide adequate sediment and erosion control; or,
- l) Violation of any contract provisions.

D. Retainage

Provided the Project is proceeding satisfactorily, SCDOT will not withhold retainage. However, if at any time SCDOT determines that CONTRACTOR fails to meet contract terms or the Project is not proceeding satisfactorily, SCDOT may retain up to 10% of the Contract Price as retainage. If the reason for SCDOT's withholding of retainage is attributable to a subcontractor's failure to perform, CONTRACTOR may withhold up to 10% of the subcontractor's payment until all work of the subcontract work is satisfactorily performed. If it decides to withhold retainage, SCDOT will not withhold more than 20% of any single payment application. SCDOT will have sole authority to determine the amount (not exceeding 10%) and necessity of retainage.

IV. CONTRACT TIME

A. Project Schedule

1. Time for Completion of Project. The Project shall be Substantially Complete within _____ calendar days from Notice to Proceed. The Notice to Proceed shall be no later than 45 days from the effective date of the Agreement. The PROPOSER must identify the time required for the construction time of the Project on the Cost Proposal Bid Form. Final Completion shall be reached as defined in paragraph 5 below.

Contract Time shall be the number of calendar days from Notice to Proceed to Substantial Work Completion which corresponds to the construction time as defined on the Cost Proposal Bid Form in **EXHIBIT 1** plus the time from Substantial Work Completion to Final Completion, not to exceed 180 days.

2. Substantial Work Completion. The Project shall be considered substantially complete when it is serviceable to the public, all lanes and ramps are open, and all work is completed except for "Project Close-out Activities", "Project Close-out

Activities” are defined as punch list items, site clean-up, demobilization, and final Project documentation, including but not limited to as-built plans.

3. Critical Path Method Schedule: CONTRACTOR shall prepare and maintain a schedule for the Project using the Critical Path Method of scheduling (hereinafter called “CPM Schedule”). Prepare a Level II CPM Schedule in accordance with this agreement and the SCDOT Supplemental Specifications with the following exceptions:

a) Submit to the SCDOT the initial baseline CPM schedule within 30 days from the Effective Date of this Agreement. No contract payment will be made to Contractor and no construction work may begin until a CPM baseline schedule is received and accepted by SCDOT. Update the baseline CPM schedule for monetary and quantitative tracking purposes as Released for Construction plans are developed.

b) Cost-load the CPM schedule using the expenses identified in the schedule of values. Use the schedule of values to establish Expense Categories and assign to the correct activities.

c) Include submittal activities. Allow duration for these activities to include SCDOT review periods.

d) Reuse of deleted activity ID’s from schedule update to schedule update is not allowed.

e) Failure to include any element of work or any activity including but not limited to utility relocation, right of way acquisition, and permitting will not relieve the CONTRACTOR from completing all work within the Contract Time at no additional time or cost to the SCDOT, notwithstanding the acceptance of the schedule by SCDOT.

f) Develop project specific calendars reflecting all seasonal restrictions included in this Agreement and non-work days. Address durations for weather within activity duration, not within the calendar.

g) Use only a Work Breakdown Structure (WBS) to organize schedule activities. At a minimum, breakout the design and construction phases. These two breakouts should have the same parent within the structure.

h) Submit monthly updates no later than 15 days following the most recent estimate period end date, whether or not an estimate was generated. Set the data date the same as the most recent estimate period end date.

i) If SCDOT determines any schedule submission is deficient, it will be returned to the CONTRACTOR. A corrected schedule shall be provided within 7 calendar days from the SCDOT’s transmittal date.

j) The schedule may indicate an early completion date. However, SCDOT will not be liable in any way for CONTRACTOR’s failure to complete the Project prior to the specified Contract Time. Any additional costs, including

extended overhead incurred between CONTRACTOR's scheduled completion date and the Contract Time, shall be the responsibility of the CONTRACTOR.

k) The schedule may include constraints to indicate the early completion of portions of the work. SCDOT will remove these constraints when determining the critical path of the schedule.

l) Include in each narrative a detailed listing of crews utilized on activities and their responsibilities. In lieu of this, the Contractor may request to submit a Resource Loaded CPM schedule.

4. Progress Review Meetings.

a) Review Meetings shall be held between CONTRACTOR and SCDOT at least every 2 weeks. Periodic construction meetings shall be held by CONTRACTOR with its consultants and subcontractors to coordinate the work, update the schedule, provide information and resolve potential conflicts.

b) SCDOT and CONTRACTOR will hold a regular CPM Progress Meeting at which all principal parties are expected to attend. These meetings will be held the week before the application for payment is due so that job progress will coincide with the payment application. At this meeting, CONTRACTOR shall provide the most recent schedule with notations showing actual start dates, actual finish dates, and activity progress. If the schedule provided indicates an actual or potential delay to the completion of the Contract, CONTRACTOR shall provide a narrative identifying the problems, causes, the activities affected and describing the means and methods available to complete the Project by the Contract Time.

5. Final Completion. When CONTRACTOR believes that all elements of its work on the Project, including all of the requirements of the Contract, have been completed, it shall notify SCDOT in writing. Final Completion shall be achieved within 180 calendar days of Substantial Work Completion as defined in this Agreement. Within thirty (30) days thereafter, SCDOT will acknowledge project completion or will advise CONTRACTOR in writing of any aspect of the Contract or the Project Scope that is incomplete or unsatisfactory. CONTRACTOR shall complete all corrective action within thirty (30) days after written notification of incomplete or unsatisfactory items. CONTRACTOR will notify SCDOT in writing upon completion of necessary corrective action. SCDOT will verify satisfactory completion of the corrective action in writing to CONTRACTOR. Upon verification, the Project shall be deemed to have achieved Final Completion.

6. Inspection/Acceptance; No Waiver. No inspection, acceptance, payment, partial waiver, or any other action on the part of SCDOT will operate as a waiver of any portion of this Agreement or of any power reserved herein or any right to damages or other relief, including any warranty rights, except insofar as expressly waived by SCDOT in writing. SCDOT will not be precluded or estopped by anything contained herein from recovering from CONTRACTOR any overpayment as may be made to CONTRACTOR.

B. Contract Time Adjustments

The Contract Time may be extended if there is a delay to the critical path of the Project caused by an event listed below. All requests for time extensions shall be made in writing to SCDOT within 20 days of the event causing the delay. All time extensions must be approved in writing by SCDOT. Time extensions may be allowed for the following events that affect the critical path:

1. Force Majeure as that term is defined in this Agreement in Article XIV;
2. Changes or construction change directives;
3. Differing site conditions as defined under Article XIII;
4. Injunctions, lawsuits, or other efforts by individuals or groups that hinder, delay, or halt the progress of the Project, provided that such efforts are not premised on alleged wrongs or violations by CONTRACTOR or its subcontractors;
5. Interference with or delay of work on the critical path of the Project by SCDOT; however, CONTRACTOR shall not be entitled to a time extension if SCDOT's actions are necessitated by CONTRACTOR's actions, omissions, failure to perform quality work, or failure to comply with contract requirements;
6. Changes in the legal requirements or regulations which are effective subsequent to the date of this Agreement;
7. Discovery of hazardous materials not previously identified as set forth in Article XI; or,
8. Discovery of archeological or paleontological remains not previously identified as set forth in Article X.
9. Adverse utility relocation impacts meeting the requirements set forth in Article VII.

C. Owner's Right to Stop Work

SCDOT will have the authority to suspend the work, wholly or in part, for such periods, as SCDOT may deem necessary, due to CONTRACTOR's failure to meet the requirements of the Contract in the performance of the work. Such suspension of the work shall not constitute grounds for claims for damages, time extensions, or extra compensation.

D. Liquidated Damages

CONTRACTOR shall pay liquidated damages to SCDOT in the amount of Ten Thousand Dollars (\$10,000.00) for each day for which construction is not substantially complete, as defined in Article IV.

CONTRACTOR shall pay liquidated damages to SCDOT in the amount of One Thousand Five Hundred Dollars (\$1,500.00) for each day that Final Completion, as defined in Article IV, is not achieved.

The parties acknowledge, recognize and agree that because of the unique nature of the Project, it is difficult or impossible to determine with precision the amount of damages that would or might be incurred by SCDOT as a result of the CONTRACTOR's failure to complete the Project as specified in the Contract. Therefore, any sums payable under this provision are in the nature of liquidated damages, and not a penalty, and are fair and reasonable and such payment represent a reasonable estimate of fair compensation for the losses that may reasonably be anticipated from such failure. Notwithstanding the above, liquidated damages are not intended to excuse the CONTRACTOR from liability for any other breach of its obligations under the Contract.

V. QUALITY ASSURANCE PROGRAM

A. CONTRACTOR's Responsibilities

CONTRACTOR shall be responsible for the QUALITY CONTROL Portion of the Program to include the items listed below. Work shall not commence until CONTRACTOR has met these requirements.

1. Quality Control Plan: CONTRACTOR shall submit a Quality Control (QC) Plan that outlines how CONTRACTOR shall assure that the materials and work are in compliance with the ~~contract documents, drawings, plans, standard specifications, contract special provisions, SCDOT Construction Manual, Inspection Training Manuals, RFP and all attachments. The Quality Control Plan shall also include the specific portions of the Transportation Management Plan that address the work item.~~ The initial plan shall be submitted to SCDOT for review and approval at least five (5) business days prior to any design or plan submittal or the beginning of any construction activity. The plan shall be updated as necessary prior to the start of any specific construction operation. The plan shall include a list of SCDOT certified personnel responsible for management and quality control of the Project, and define the authority of each individual. The plan shall also include how CONTRACTOR will monitor quality and deal with failing materials. The QC Plan shall include the QC testing and sampling frequencies and shall indicate the frequency at which the QC Manager will provide QC test results to SCDOT. CONTRACTOR shall include an estimated summary of quantities to SCDOT for the purposes of meeting the minimum sampling and testing requirements in accordance with the SCDOT Construction Manual.

2. Personnel: CONTRACTOR shall provide a sufficient number of SCDOT certified personnel to adequately control the work of the Project. Any personnel required to obtain samples or conduct material testing shall be SCDOT certified. ~~or adequately trained and qualified as determined by SCDOT. Training, qualification, and/or certification shall include classroom training, written testing, documented demonstration of proper inspection, sampling and testing procedures, pre-employment training and an on-the-job training period.~~ CONTRACTOR shall provide SCDOT with copies of each individual's ~~training, qualifications, and/or~~ certifications, ~~in resume form, as required,~~ for review and approval by SCDOT. Approved CONTRACTOR QC personnel shall be on the job at all times that permanent work items and materials are being incorporated into the project. CONTRACTOR's QC personnel shall not have any other project responsibilities.

1. CONTRACTOR Testing: CONTRACTOR is required to conduct asphalt sampling and testing in accordance with ~~QC/QA special provisions and supplemental specifications for asphalt included in EXHIBIT 5,~~ the SCDOT Supplemental Standard Specifications, and the SCDOT Supplemental Technical Specifications SC-M-400. ~~CONTRACTOR may elect to shall~~ conduct ~~other~~ sampling and testing to ensure that all workmanship and materials are in compliance with the contract requirements ~~for its own benefit.~~ Although not used for acceptance, QC testing and inspection shall ensure that quality has been incorporated into all elements of work prior to requesting acceptance testing and inspection. The QC Program should be sufficient in scope to remedy repeated discoveries of non-compliant work by those performing acceptance inspection and testing. Repeated observations of QC quality shortfalls shall be considered a breakdown of the QC program and shall be cause for investigation and corrective action prior to commencement of work areas affected. Corrective action may include the addition of new QC procedures, revision to existing QC procedures, re-training of QC personnel, removal and replacement of QC personnel, or other such actions which will restore the effectiveness of the QC program. All QC testing shall be performed in accordance with existing AASHTO, ASTM, or test methods used by SCDOT. The cost of these activities will be borne by CONTRACTOR. Additionally, CONTRACTOR is responsible for dynamic and static load testing of drilled shafts and piles in accordance with the requirements of **EXHIBITS 4 and 5.**

2. Testing Laboratories: All testing laboratories used on the Project must be AASHTO certified and approved by SCDOT thirty (30) days prior to beginning the portion of work for which the laboratory will be performing the testing. **Hot Mix Asphalt testing laboratories require SCDOT certification.**

3. Mix Designs: Copies of all initial hot-mix asphalt mix designs and Portland Cement Concrete mix designs, along with supporting data, shall be submitted to SCDOT for review at least five (5) business days prior to use. All hot-mix asphalt mix designs will be prepared by personnel certified in Mix Design Methods. Portland Cement Concrete mix designs will be prepared by a certified concrete technician or a Professional Engineer. The Portland Cement Concrete mix proportions given in the specifications are to be followed. CONTRACTOR shall design the mix to obtain the strength and water/cement ratios given in the specifications, and shall provide workability, air content,

gradation and suitable set times as set forth in the Standard Specifications. The SCDOT will be notified of any revisions to CONTRACTOR's mix design. Copies of such revisions will be sent to SCDOT for review at least ten (10) business days prior to use.

4. Materials Certifications: CONTRACTOR's QC Manager shall submit all material certifications ~~for approval by to~~ SCDOT prior to the CONTRACTOR incorporating the material into the project. ~~and applying for payment for work in which the material was incorporated. Upon Completion of the project, CONTRACTOR shall submit to SCDOT a letter of certification stating that, based upon an analysis of all materials test results, all materials incorporated into the Project were found to be in substantial conformance with the requirements of the plans and specifications. A list of any exceptions and all failing test results will be provided, along with a record of disposition of the material represented by these tests.~~

B. SCDOT Responsibilities

SCDOT will be responsible for the QUALITY ACCEPTANCE portion of the program to include: conducting inspections, acceptance testing, independent assurance testing and final project material certification.

1. Acceptance Testing: SCDOT personnel assigned to the Project, or qualified personnel retained by SCDOT, will conduct sampling and testing, separate from CONTRACTOR's testing, at the frequencies set forth in SCDOT's construction manual. This testing will be used by SCDOT to determine the acceptability of the materials. All sampling and testing will be in accordance with existing AASHTO, ASTM, or SC test methods used by SCDOT. The cost of these activities will be borne by SCDOT. CONTRACTOR's QC Manager is required to coordinate ~~its all~~ activities closely with SCDOT to allow the necessary acceptance testing to be conducted prior to proceeding to the next operation. The disposition of failing materials must be approved by SCDOT.

2. Independent Assurance Testing: SCDOT will be responsible for conducting Independent Assurance Testing. Personnel performing these tests will be SCDOT employees or qualified persons retained by SCDOT. Persons performing these tests will not be involved in Acceptance Testing. This testing will be used to ensure that proper sampling and testing procedures are being followed, and that testing equipment is functioning properly. This testing will consist of observing sampling and testing by both SCDOT personnel performing Acceptance Testing and CONTRACTOR personnel performing Quality Control Testing, as well as taking split samples for the purposes of comparison testing. Independent Assurance Testing will be at an approximate frequency of one-tenth of the Acceptance Testing frequency. Independent Assurance test results will not be used for acceptance. The cost of these activities will be borne by SCDOT.

3. Materials Certification: SCDOT will be responsible for preparing the Materials Certification as required by the FHWA on federally funded projects.

C. CONTRACTOR's Obligation

SCDOT's testing in no way relieves CONTRACTOR of its obligation to comply with the Contract requirements. All materials incorporated into the Project must meet or exceed contract requirements and specifications. Further, any testing by SCDOT will not relieve CONTRACTOR of any of its warranty obligations.

VI. INSURANCE AND BONDING

A. Insurance

1. CONTRACTOR shall purchase and maintain in a company or companies that maintain an A.M. Best rating of not less than A-VII with coverage forms acceptable to SCDOT. The insurance described below shall be maintained uninterrupted for the duration of the Project, including warranty periods, and shall protect CONTRACTOR from claims set forth below which may arise out of or result from CONTRACTOR's operations under the Contract, whether such operations be performed by CONTRACTOR or by any subcontractor or by anyone directly or indirectly employed by any of them or by anyone for whose acts any of them may be liable:

- a) Claims under workers' or workmen's compensation, disability benefit and other similar employee benefit acts;
- b) Claims for damages because of bodily injury, occupational sickness or disease, or death of CONTRACTOR's employees;
- c) Claims for damages because of bodily injury, sickness or disease, or death of any person other than CONTRACTOR's employees;
- d) Claims for damages insured by usual personal injury liability coverage which are sustained (1) by any person as a result of an offense directly or indirectly related to the employment of such person by CONTRACTOR, or (2) by any other person;
- e) Claims for damages, other than to the work itself, because of injury to or destruction of tangible property, including loss of use resulting therefrom;
- f) Claims for damages because of bodily injury or death of any person or property damage arising out of the ownership, maintenance or use of any motor vehicle.
- g) Claims involving contractual liability insurance applicable to the Contractor's obligations under the indemnity provisions of this contract.

2. The minimum limits of liability for the following types of insurance are required, except where greater limits are required by statute:

a) Workers' Compensation, including: Worker's Compensation Insurance/Employer's Liability

State Statutory limits	Employer's Liability
	\$100,000 per accident
	\$500,000 per disease
	\$100,000 each employee

- b) Commercial General Liability \$1,000,000 per occurrence
\$2,000,000 aggregate

Commercial General Liability insurance shall be written on ISO occurrence form CG 00 01 (or substitute for providing equivalent coverage) and shall cover liability arising from premises, operations, independent contractors, products-completed operations, contractual liability and personal injury and advertising injury. The policy shall contain the per project endorsement.

- c) Business Automobile Liability \$1,000,000 per occurrence

This policy shall cover Any Auto, including Owned, Hired and Non-owned Automobiles. Business auto coverage shall be written on ISO form CA 00 01, CA 00 05, CA 00 12, CA 00 20, or a substitute form providing equivalent liability coverage.

- d) Umbrella Liability Coverage \$10,000,000 per occurrence
\$20,000,000 aggregate

The general aggregate limit shall apply separately to the Project

3. Certificates of Insurance acceptable to SCDOT will be provided to SCDOT prior to execution of this Agreement. These certificates shall name SCDOT as an additional insured under the Commercial General Liability (CGL) arising out of both the on-going operations and completed operations of CONTRACTOR. Such additional insured coverage shall be endorsed to Contractor's CGL policy using ISO Additional Insured Endorsement form CG 2010 (10/01) and CG 2037 (10/01) or a substitute providing equivalent coverage, and included under the commercial umbrella. CONTRACTOR shall maintain continual additional insured status for SCDOT under the products-completed operations coverage for the time period required to satisfy the statute of limitation for South Carolina. CONTRACTOR shall also name SCDOT as additional insured under Business Automobile and Umbrella policies and reference the Project to which the certificate applies. The policies must contain a provision that coverage afforded will not be canceled or reduced until at least 30 days prior written notice has

been given to SCDOT and that the policies cannot be cancelled for non-payment of premiums until at least 10 days prior written notice has been provided to SCDOT. Send Notice of Cancellations to Director of Construction Room 330, PO Box 191, Columbia, SC 29202. Make certain that the policies are endorsed to reflect this requirement. Verification of additional insured status shall be furnished to SCDOT by including a copy of the endorsements with the Certificate of Insurance. This insurance, including insurance provided under the commercial umbrella shall apply as primary and noncontributory insurance with respect to any other insurance or self-insurance programs, including any deductibles, afforded to, or maintained by, SCDOT. CONTRACTOR'S deductibles shall not exceed \$250,000 without written consent of the SCDOT and that the certificates show the deductible amounts.

4. Limits shown in this provision are minimum acceptable limits and in no way limit available coverage to the additional insured. CONTRACTOR's CGL and commercial umbrella policies shall contain no provision providing that the limits available to an additional insured are less than the limits available to the CONTRACTOR. SCDOT shall be given all the same rights and insurance coverage as CONTRACTOR. In the event that any insurer issues a reservation of rights for SCDOT as an additional insured, SCDOT shall be entitled to employ independent counsel, of its choice, at CONTRACTOR's expense.

5. There shall be no endorsements or modifications of the CGL limiting the scope of coverage for liability arising from explosion, collapse, underground property damage or work performed by contractors on behalf of SCDOT.

6. Hazardous waste. If the CONTRACTOR is required to remove and haul any hazardous waste from the Project, or if the Project involves such similar environmental exposure, pollution liability coverage equivalent to that provided under the ISO Pollution Liability – Broadened Coverage for Covered Autos Endorsement (CA 99 48) shall be provided, and the Motor Carrier Act Endorsement (MCS 90) shall be attached. Limits of pollution liability shall be not less than \$1,000,000 per occurrence. Coverage shall apply on an “occurrence form” basis, shall cover at a minimum bodily injury, property damage, defense costs and clean-up costs and be extended to include non-owned disposal sites and transportation coverage. This insurance shall remain in effect after acceptance by Owner for the time period required to satisfy the statute of limitations in South Carolina. However, if coverage is written on a “claims made form”, then the Contractor's Pollution Liability coverage shall include a retroactive date that precedes the commencement of work under this Agreement. Such coverage shall apply as primary and non-contributory insurance with respect to any other insurance or self-insurance programs, including any deductibles, afforded to, or maintained by SCDOT.

7. Waiver of Subrogation. CONTRACTOR shall waive its rights against SCDOT, other additional insured parties, and their respective agents, officers, directors and employees for recovery of damages, or any other claims, to the extent these damages are covered by the CGL, business auto, workers compensation and employer's liability or commercial umbrella maintained pursuant to this section of the Agreement.

8. CONTRACTOR shall at the time of execution of this Agreement, obtain Errors and Omissions insurance for their Professional Liability, for all claims arising from the performance of professional services on the Project. The insurance coverage shall be for not less than Three Million Dollars (\$3,000,000) per claim and in the aggregate. The coverage shall be continued for three (3) years after the date of Final Completion of the Project. Evidence of such insurance shall be provided to SCDOT at the time of the execution of the Agreement.

~~9. CONTRACTOR shall provide "Builders Risk Insurance" acceptable to the SCDOT in the amount of the Contract Price protecting the respective interests of SCDOT and CONTRACTOR and covering physical loss or damage to the work during construction of the Project. The certificate of insurance shall be provided to the SCDOT at the time of execution of this Agreement. The policy shall name the SCDOT as an additional insured and shall reference the Project by name. The certificate shall also state that the coverage will not be cancelled or reduced without 30 days prior written notice to the SCDOT.~~

10. After completion of the work, CONTRACTOR shall maintain CGL and commercial umbrella coverage to include liability coverage for damage to insured's completed work equivalent to that provided under ISO CG 00 01 for three (3) years or for the statute of limitations period for damages, whichever is greater.

11. By execution of the contract, the CONTRACTOR accepts the responsibility to provide the liability insurance policies and endorsements as specified herein. Failure of SCDOT to identify a deficiency in the Certificate of Insurance submitted by the CONTRACTOR's insurance agent as evidence of the specified insurance or to request other evidence of full compliance with the liability insurance specified shall not be construed as a waiver of the CONTRACTOR's obligation to provide and maintain the required insurance for the duration of the contract.

B. Bonding

1. CONTRACTOR shall at the time of the execution of this Agreement, provide SCDOT the following bonds:

a) A Performance and Indemnity Bond from a surety or sureties satisfactory to SCDOT. The amount of bond shall be equal to the Contract Price.

b) A Payment Bond from a surety or sureties satisfactory to SCDOT. The amount of bond shall be equal to the Contract Price.

These bonds shall be in accordance with the requirements of S.C. Code Ann. §57-5-1660, (1976 as amended) and S.C. Code Ann. §29-6-250 (2000). Bonds shall be issued by a surety company licensed in the State of South Carolina with an "A" minimum rating of performance as stated in the most current publication of "A.M. Best Key Rating Guide, Property Liability" and signed by the surety's agency or attorney-in-fact. Surety

must be listed on the current U.S. Department of the Treasury Financial Management Service list of approved bonding companies as approved for an amount equal to or greater than the amount for which it obligates itself in the Bond. If surety qualifies by virtue of its Best's listing, the amount of the Bond may not exceed ten percent of policyholders' surplus as shown in the latest A.M. Best's Key Rating Guide.

2. CONTRACTOR shall also provide a warranty bond, acceptable to SCDOT, in the amount of Three Million Dollars (\$3,000,000) to cover the warranty obligations of the contract.

VII. UTILITIES AND RAILROAD COORDINATION

A. As part of the Project Scope, CONTRACTOR shall have the responsibility of coordinating the Project construction and demolition activities with all utilities that may be affected. CONTRACTOR shall be responsible for the cost of utility coordination as defined herein. If applicable, all temporary relocation costs as well as any other conflict avoidance measures shall be the responsibility of the CONTRACTOR. For those utilities that have prior rights SCDOT will be responsible for permanent relocation costs as defined by the Federal code. For those utilities where the CONTRACTOR determines that the SCDOT has prior rights, CONTRACTOR may exercise these rights and require the utility company to bear the costs of relocation. If there is a dispute over prior rights, SCDOT shall be responsible for resolving the dispute. SCDOT shall have final determination of the utility's prior rights.

B. For those utilities requiring relocation, CONTRACTOR shall conform with SCDOT's "A Policy for Accommodating Utilities on Highway Rights of Way", the applicable State laws, and the Code of Federal Regulations, Title 23, Chapter 1, Subchapter G, part 645, subparts A and B.

C. The resolution of any conflicts between utility companies and the construction of the Project shall be the responsibility of the CONTRACTOR. If said utility companies interfere or fail to relocate conflicting utilities in a timely manner, SCDOT may, on an individual basis, consider a time extension for utility company delays when CONTRACTOR can demonstrate that appropriate coordination efforts have been made to expedite the utility relocation, and that the delay has a direct impact on the approved Critical Path. CONTRACTOR shall not be entitled to additional compensation for interference or delays in utility relocations. CONTRACTOR shall meet with the Department's Utilities Office within thirty (30) days of the Notice to Proceed to gain a full understanding of what is required with each utility submittal.

D. CONTRACTOR shall design the Project to avoid conflicts with utilities where possible, and minimize impacts where conflicts cannot be avoided. If there is a dispute between the CONTRACTOR and SCDOT as to whether a utility relocation is required, SCDOT shall have the final determination. Additional utility relocations desired by the CONTRACTOR for but not limited to construction staging, access or convenience, shall be the sole responsibility of CONTRACTOR and all associated costs shall be borne by the CONTRACTOR.

E. CONTRACTOR shall initiate early coordination with all utilities and provide the utility companies with design plans for their use in developing Relocation Sketches as soon as the plans have reached a level of completeness adequate to allow the companies to fully understand the Project impacts. If a party other than the utility company prepares Relocation Sketches, there shall be a concurrence box on the plans where the utility company signs and accepts the Relocation Sketches as shown.

F. CONTRACTOR shall be responsible for collecting and submitting to SCDOT the following from each utility company that is located within the project limits:

1. **Relocation Sketches** including letter of “no cost” where the company does not have a prior right;
2. **Utility Agreements** including documentation of prior rights, cost estimate and relocation plans where the company has a prior right; and/or
3. **Letters of “no conflict”** where the company’s facilities will not be impacted by the Project. Include location sketches on SCDOT plans confirming and certifying that facilities are not in conflict.
4. **Encroachment Permits** for all relocations regardless of prior rights.

G. CONTRACTOR shall assemble the information included in the Utility Agreements and Relocation Sketches in a final and complete form and in such a manner that the Department may approve the submittals with minimal review. CONTRACTOR shall ensure that there are no conflicts with the proposed highway improvements, or between each of the utility company’s relocation plans. CONTRACTOR may not authorize the utility companies to begin their relocation work until authorized in writing by SCDOT. Any early authorization by CONTRACTOR shall be at the CONTRACTOR’s risk.

H. At the time that CONTRACTOR notifies SCDOT that CONTRACTOR deems the Project to have reached Final Completion, CONTRACTOR shall certify to SCDOT that all utilities have been identified and that those utilities with prior rights or other claims related to relocation or coordination with the Project have been relocated or their claims otherwise satisfied or will be satisfied by CONTRACTOR.

I. CONTRACTOR shall accurately show the final location of all utilities on the as-built drawings for the Project.

Railroad property is impacted by this project, provisions J through R shall apply:

J. Under the direction of and in coordination with SCDOT, the CONTRACTOR shall be responsible for all coordination with the involved Railroad Companies, including but not limited to, sending plans, meetings, correspondence, phone calls, writing/reviewing agreements, and etc. as may be necessary to secure the applicable executed railroad agreements, needed for the construction of the project, between the SCDOT and all involved railroad companies. All correspondence related to railroad agreements or conditions shall include the railroad file number

and railroad milepost information. The CONTRACTOR shall be responsible for the cost of railroad coordination as defined herein.

K. SCDOT will submit for approval, all required railroad agreements necessary for the Preliminary Engineering and Construction of the project. Upon approval, the SCDOT will submit the agreement to the Railroad Company for execution. The CONTRACTOR shall be responsible for assisting SCDOT in the development of the railroad agreement by providing requested information.

L. The CONTRACTOR shall be responsible for all costs to the Railroad Company or Companies for services provided by the Railroad or the Railroad's Agent, as detailed in the executed Railroad Agreement between the SCDOT and the Railroad. This includes all expenses such as railroad flagging operations. The CONTRACTOR shall be responsible for all other costs associated with designing and constructing the project as described in the executed Railroad Agreement between the SCDOT and the Railroad Company. The CONTRACTOR shall include all costs associated with these requirements in the final bid price. Once a contract is executed, SCDOT shall administer invoicing for costs to the Railroad Company or Companies. Monies will be deducted from the CONTRACTOR's progress payments.

M. All design and construction activities in, adjacent to, over or under the railroad shall comply with all applicable Federal and State laws and standards, all terms identified in the Special Provisions for Protection of Railway Interests, and all terms of the final agreement executed with the Railroad Company.

N. The CONTRACTOR will be required to meet the Railroad's Insurance Requirements as specified in the Special Provisions for Protection of Railway Interests.

O. The CONTRACTOR shall attend a mandatory meeting with the SCDOT's Utilities Office and Railroad Projects Office within thirty (30) days after the Notice to Proceed. The CONTRACTOR will be required to use the SCDOT approved agreement language and procedures, that will be provided in this meeting.

P. SCDOT has negotiated language for the PE and Construction Agreements (see Exhibit 8). CONTRACTOR shall provide project specific information to SCDOT for inclusion into the agreements. The CONTRACTOR shall anticipate and include in the proposed schedule a minimum 90-day approval time-frame for all railroad agreements. However, SCDOT will not be held responsible for delays caused by negotiations with the railroad company.

Q. CONTRACTOR shall anticipate the need for a separate right-of-entry agreement between the CONTRACTOR and Railroad for surveys, borings, etc. The required PE Agreement, between SCDOT and Railroad, must be executed before Railroad will review or comment on any design questions or submittals from the CONTRACTOR. The Construction Agreement, between SCDOT and Railroad, must be executed before any construction activities can begin.

R. CONTRACTOR is advised the all utility relocations required within railroad right-of-way will require separate agreements between the affected utility company and the Railroad.

VIII. RIGHT OF WAY ACQUISITION

A. Right of Way Services

CONTRACTOR, acting as an agent on behalf of the State of South Carolina, shall provide right-of-way services for the Project. CONTRACTOR shall use firm(s) from the SCDOT's current "on-call" list for right of way consultants, as listed in Attachment B, to provide right of way services. Right-of-way services shall include appraisal, appraisal review, negotiation, acquisition, and relocation assistance services. CONTRACTOR shall be responsible for all costs related to these right-of-way services. CONTRACTOR will provide expert testimony and SCDOT will provide legal services necessary for any cases that are to be resolved by trial. Experts are defined as engineering and appraisal witnesses. SCDOT will retain final authority for approving just compensation, relocation benefits and settlements. SCDOT will designate a hearing officer to hear any Relocation Assistance Appeals. SCDOT agrees to assist with any out of state relocation by persons displaced within the rights of way by arranging with such other state(s) for verification of the relocation assistance claim. CONTRACTOR shall carry out the responsibilities as follows:

1. Acquire property in accordance with all Federal and State laws and regulations, including but not limited to the Uniform Relocation and Real Property Acquisition Act of 1970, as amended (the "Uniform Act") and the South Carolina Eminent Domain Procedure Act ("The Act"). The acquisition of property shall follow the guidelines as established by the Department and other State and Federal guidelines. CONTRACTOR shall not be entitled to an increase in the Contract Price for acquisition of borrow sources.

2. Submit procedures for handling right-of-way acquisitions and relocations to the SCDOT for approval prior to commencing right-of-way activities. These procedures are to show CONTRACTOR'S method including the appropriate steps and workflow required for appraisal, acquisition, and relocation. CONTRACTOR shall be granted the authority for administrative settlements by the SCDOT's Right-of-Way Office upon review and approval of the Right-of-Way Procedures. These procedures should also include an appropriate time allowance for SCDOT to establish just compensation, approve relocation benefits, and approve administration and legal settlements. A SCDOT Representative will be available to make timely decisions concerning establishing just compensation, approving relocation benefits, and approving administrative settlements on behalf of SCDOT. The SCDOT Representative is committed to issuing decisions on approval requests within three (3) business days. The commitment is based on the procedure providing a reasonable and orderly workflow and the work being provided to the SCDOT Representative as completed.

3. Utilize SCDOT's right-of-way project tracking system and provide an electronic status update a minimum of twice per month or upon request by SCDOT's representative.
4. Submit a right-of-way quality control plan to the SCDOT for review prior to commencing right-of-way activities. SCDOT standard forms and documents will be used to the extent possible.
5. Provide a toll free telephone number for landowners and displaced persons to call.
6. Provide a current title certificate by a licensed South Carolina attorney for each parcel as of the date of closing or the date of filing of the Condemnation Notice.
7. Prepare appraisals in accordance with the Department's Appraisal Manual. Appraisals shall be prepared by appraisers who are on the SCDOT approved list of active fee appraisers.
8. Provide appraisal reviews complying with technical review guidelines of SCDOT Appraisal Manual and make a recommendation of just compensation. The reviewer shall be from the SCDOT's approved reviewer list.
9. Make direct payments of benefits to property owners for negotiated settlements, relocation benefits and payments to be deposited with the court and notify SCDOT monthly of payments made.
10. Prepare, obtain execution of, and record documents conveying title to such properties to SCDOT with Register of Deeds, and deliver all executed and recorded general warranty deeds to SCDOT. For all property purchased in conjunction with the Project, title will be acquired in fee simple (except that SCDOT may in its sole discretion direct the acquisition of a right-of-way easement or permissions, in lieu of fee simple title, with respect to any portion of the Rights of Way) and shall be conveyed to "The South Carolina Department of Transportation" by general warranty deed, free and clear of all liens and encumbrances except permitted encumbrances.
11. Because these acquisitions are being made as agent on behalf of the State of South Carolina, SCDOT shall make the ultimate determination in each case as to whether settlement is appropriate or whether the filing of a condemnation action is necessary, taking into consideration the recommendations of the CONTRACTOR. When SCDOT authorizes the filing of a condemnation, CONTRACTOR shall prepare a Notice of Condemnation in the name of SCDOT, and submit it to SCDOT for SCDOT to file and serve appropriate condemnation documents and pleadings, and request priority status pursuant to S.C. Code Ann. Section 28-2-310(1976, as amended).
12. SCDOT shall prosecute condemnation proceedings to final judgment pursuant to the requirements of the South Carolina Eminent Domain Procedures Act.

The procedure shall be by way of trial as provided by Section 28-2-240 of “The Act”. SCDOT shall be responsible for obtaining legal representation and CONTRACTOR will be responsible for providing expert witnesses necessary for condemnation actions. All settlements of condemnation cases shall be at SCDOT’s sole discretion.

13. CONTRACTOR will be responsible for all contacts with landowners for rights-of-way or construction items and shall provide the following:

- a) All Notices of Condemnation, issued pursuant to the authority granted, all titles of real estate and all right of way easements, permissions, or right-of easements, recorded with the Office of the Register of Deeds or the Clerk of Court for the county or counties in which properties acquired through condemnation are located;
- b) A right-of-way agent’s worksheet, or documents substantially in the format of SCDOT Form No. 809, for each tract.

14. CONTRACTOR shall provide a right-of-way certification and SCDOT shall approve that certification prior to CONTRACTOR entering the property. Only in exceptional circumstances will a certification be approved based on a right of entry. Certification may be on a tract-by-tract basis.

15. CONTRACTOR shall exercise care in its operations when working in proximity to adjacent developed properties, properties not yet acquired, and residences or businesses that are to be relocated. CONTRACTOR shall submit a plan to the SCDOT’s right-of-way representative for approval to:

- a) Establish a clear zone adjacent to properties occupied by persons to be displaced in which construction equipment may not be operated or parked,
- b) Establish a clear zone for construction for properties occupied by persons to be displaced to prevent undue impacts or hardships,
- c) Establish a method of protecting equipment from vandalism or unauthorized use,
- d) Locate brush piles and mulching/grinding operations more than 500 feet from an occupied business or residence, or as required by South Carolina Department of Health and Environmental Control burning regulations,
- e) Provide reasonable and safe access to residences or businesses that are to be displaced until such time as the property is vacant, and

- f) Observe the property rights of landowners of adjacent and/or yet to be acquired properties.

16. CONTRACTOR shall use reasonable care in determining whether there is reason to believe that property to be acquired for rights-of-way may contain concealed or hidden wastes or other materials or hazards requiring remedial action or treatment. When there is reason to believe that such materials may be present, CONTRACTOR shall take steps consistent with customary SCDOT practices to investigate. SCDOT shall be notified of the presence of such materials before an offer is made to acquire the property.

17. During the acquisition process and for a period of three years after final payment is made to CONTRACTOR for any phase of the work, all project documents and records not previously delivered to SCDOT, including but not limited to design and engineering costs, construction costs, costs of acquisition of rights-of-way, and all documents and records necessary to determine compliance with the laws relating to the acquisition of rights-of-way and the costs of relocation of utilities, shall be maintained and made available to SCDOT for inspection or audit.

B. Acquisition of Right-of-Way

1. The CONTRACTOR is responsible for verification of all information necessary for acquisition of the Right-of-Way and is responsible for all costs, excluding premium cost as defined below, associated with the purchase of the Right-of-Way. The CONTRACTOR shall acquire the property as an agent on behalf of the State of South Carolina.

2. Acquisition of any additional area desired by the CONTRACTOR necessary to complete the project, shall comply with this Article of the Contract, with the exception of cost allocation.

3. All costs associated with the acquisition of any additional area are the sole responsibility of the CONTRACTOR, including premium right-of-way costs. CONTRACTOR shall abide by the provisions of all applicable environmental permits, any conditions of individual right of way agreements, and all environmental commitments. Any necessary permit modifications are the responsibility of the CONTRACTOR.

4. Acquisition of any additional area desired by the CONTRACTOR for, but not limited to, construction staging, access or borrow pits shall be the sole responsibility of CONTRACTOR, and any title or interest shall be secured in the name of the CONTRACTOR. CONTRACTOR shall provide SCDOT the location and documentation for these additional areas. CONTRACTOR shall furnish SCDOT a copy of any agreements, whether for purchase or lease, for the use of additional properties in conjunction with the construction of the Project. CONTRACTOR shall abide by the provisions of all applicable environmental permits, any conditions of individual right of way agreements, and all environmental commitments. Any necessary permit modifications are the responsibility of the CONTRACTOR. CONTRACTOR is

responsible for all costs associated with these additional areas, including premium right-of-way costs. If additional right-of-way is necessary beyond what has been evaluated in the NEPA documentation, CONTRACTOR shall be responsible for any re-evaluation of the approved Environmental Documents.

5. ROW acquisition costs shall be defined as amounts paid for: (1) direct payments for ownership or other property rights, and (2) direct payments for eligible relocation expenses as provided for under the Uniform Act less Premium ROW acquisition costs.

6. Premium ROW acquisition costs shall be the amount a jury award or a settlement that exceeds "Just compensation." "Just compensation" shall be defined as the value SCDOT approves for a parcel after the following procedure: CONTRACTOR shall submit its recommendation for just compensation based on appraisals and appraisal reviews which support the recommendation. If SCDOT approves CONTRACTOR'S recommendations, that value becomes just compensation. If SCDOT does not approve the recommendation, CONTRACTOR or SCDOT shall obtain another appraisal using an appraiser from the SCDOT's approved list and submit this appraisal to SCDOT. SCDOT shall be responsible for the cost of the second appraisal. SCDOT shall assign a value to the parcel which shall be deemed just compensation supported by the appraisals for the parcel.

7. CONTRACTOR shall be responsible for right-of-way service costs and right-of-way acquisition costs.

8. SCDOT shall be responsible for premium right-of-way costs except for those additional areas explained above.

9. Upon final completion of the project, if any right-of-way condemnation actions are still pending, CONTRACTOR shall provide reasonable and adequate security to cover its contractual obligation relating to right-of-way acquisition.

IX. PERMITS

A. All permits necessary for completion of this project shall be procured by the CONTRACTOR. The CONTRACTOR shall comply with all local, state, and federal permitting requirements. Regarding any permit or license that must be obtained in the name of SCDOT, the CONTRACTOR shall perform all functions within its power to obtain the permit or license, and SCDOT shall fully cooperate in this effort and perform any functions that must be performed by SCDOT. The CONTRACTOR shall submit permit applications to SCDOT. SCDOT will submit the permit application to the appropriate permitting agency indicating that CONTRACTOR is acting as an agent for SCDOT. If said regulatory agencies fail to issue permits in a timely manner, SCDOT may, on an individual basis, consider a time extension for permit approval delays when CONTRACTOR can demonstrate that the application was submitted in a timely manner, all reasonable efforts have been made to expedite the permit

approval, and that the delay has a direct impact on the Critical Path. CONTRACTOR shall not be entitled to additional compensation for delays in permit approval.

B. All necessary permit modifications shall be the CONTRACTOR's responsibility. All work associated with permit modifications as a result of changes proposed by CONTRACTOR shall be CONTRACTOR's responsibility. See Article II.B.4 regarding deductions for waived fees.

X. ENVIRONMENTAL COMPLIANCE

A. Compliance with Environmental Commitments

CONTRACTOR shall comply with all Environmental commitments and requirements including, but not limited to, the following:

1. Compliance with the provisions of all environmental permits applicable to the Project. A copy of the environmental document is included in **Attachment B**. Environmental Commitments are included in **Exhibit 4**.
2. Compliance with those stipulations and conditions under which SCDOT received approval of the Environmental Document(s) and any modifications resulting from a re-evaluation of the Document(s). If the CONTRACTOR elects to construct the Project in a manner that is not consistent with the assumptions in the SCDOT prepared environmental documents, the CONTRACTOR will be responsible for revising the environmental documents and provide any additional studies that may be required. All revisions will require SCDOT and FHWA approval prior to any right of way acquisition or construction activity;
3. Compliance with applicable laws and regulations relating to potential or actual hazardous materials that may be encountered in the course of carrying out this Agreement;
4. Carrying out all necessary social, economic, and environmental studies required by regulatory authorities in the course of construction;
5. Preparation, revision, acquisition, compliance, and adherence to conditions of any permits required by federal, state, or local laws or regulations; The CONTRACTOR is responsible for any mitigation required by permits; and
6. The resolution of any deviations from the contract documents, drawings or other information included in the environmental permits that would violate the intent or spirit of the permits. Any proposed changes within the permitted areas would need to be coordinated with SCDOT's Environmental Management Office.

B. Preconstruction / Partnering Conference(s)

CONTRACTOR shall conduct one (or more, if appropriate) pre-construction / partnering conference(s) prior to any construction activity to discuss environmental and permitting issues, which conference shall include all subcontractors, and, to the extent feasible, representatives from the U.S. Army Corps of Engineers, the S.C. Department of Health and Environmental Control Water Quality Division, the Federal Highway Administration, CONTRACTOR, and SCDOT.

C. Protection of Archeological and Paleontological Remains and Materials

1. When archeological or paleontological remains are uncovered, CONTRACTOR shall immediately halt operations in the area of the discovery and notify SCDOT.

2. Archeological remains consist of any materials made or altered by man which remains from past historic or prehistoric times (i.e. older than 50 years) Examples include old pottery fragments, metal, wood, arrowheads, stone implements or tools, human burials, historic docks, structures or not recent (i.e. older than 100 years) vessel ruins. Paleontological remains consist of old animal remains, original or fossilized, such as teeth, tusks, bone, or entire skeletons.

3. SCDOT will have the authority to suspend the work for the purpose of preserving, documenting, and recovering the remains and materials of archeological and paleontological importance for the State. CONTRACTOR shall carry out all instructions of SCDOT for the protection of archeological or paleontological remains, including steps to protect the site from vandalism and unauthorized investigations, from accidental damage and from dangers such as heavy rainfall or runoff.

4. CONTRACTOR's Contract Time and or Contract Price shall be adjusted to the extent CONTRACTOR's cost and /or time of performance have been adversely impacted by the presence of archeological or paleontological remains.

D. Community and Public Relations Plan

The CONTRACTOR shall provide to SCDOT for review and written approval a Community Relations Plan as part of the Project. The Community Relations Plan shall describe how the CONTRACTOR will actively promote good relationships with local elected officials, the news media, and the community at large. All costs associated with community relations will be included in the Total Project Cost. SCDOT will expect the CONTRACTOR to maintain positive communications with the local community (including public meetings as necessary), the adjacent property owners, and local businesses. The Community Relations Plan shall be submitted within 45 calendar days after NTP.

XI. HAZARDOUS MATERIALS

A. The CONTRACTOR is referred to Attachment B for information regarding Hazardous Materials Surveys. The CONTRACTOR shall anticipate that the structural steel components contain lead-based paints. When required by the CONTRACTOR's plan, the CONTRACTOR shall remove and dispose of the structural steel components containing lead-based paints in compliance with all applicable Federal (EPA, OSHA & DOT) and State requirements for lead as waste, lead in air, lead in water, lead in soil, and worker health and safety. The cost the removal and disposal of components containing lead-based paints shall be included in the Contract Price. If the CONTRACTOR's plan includes demolition, removal, or disposal of existing structures not previously surveyed by SCDOT, the CONTRACTOR is required to perform asbestos and lead paint inspections on the existing structures prior to performing those activities. A copy of the lead and asbestos report and a notification of demolition or renovation forms must be submitted to the South Carolina Department of Health and Environmental Control at least ten (10) working days prior to demolition of an existing structure. The CONTRACTOR is responsible for obtaining all required permits to proceed with the work. The CONTRACTOR is responsible for required containment and disposal of the asbestos. The cost of removal and disposal of components containing asbestos shall be included in the Contract Price.

B. Except as noted in paragraph "A" above, CONTRACTOR is not responsible for handling, storage, remediation, or disposal of any materials, wastes, substances and chemicals deemed to be hazardous under applicable state or federal law, (hereinafter "Hazardous Conditions") encountered at the Site which were not previously identified or introduced to the site by CONTRACTOR or any of its agents. Upon encountering any Hazardous Conditions, CONTRACTOR shall stop Work immediately in the affected area and duly notify SCDOT and, if required by state or federal law, all government or quasi-government entities with jurisdiction over the Project or site.

C. Upon receiving notice of the presence of Hazardous Conditions, SCDOT will take necessary measures required to ensure that the Hazardous Conditions are remediated or rendered harmless. Such necessary measures will include SCDOT either (i) retaining qualified independent firm or (ii) negotiating a construction change directive with CONTRACTOR.

D. CONTRACTOR shall resume Work at the affected area of the Project only after written notice from SCDOT that the (i) Hazardous Conditions have been removed or rendered harmless and (ii) all necessary approvals have been obtained from all government and quasi-government entities having jurisdiction over the Project.

E. CONTRACTOR's Contract Price and/or Contract Time shall be adjusted to the extent CONTRACTOR's cost and/or time of performance has been adversely impacted by the presence of Hazardous Conditions.

F. SCDOT is not responsible for Hazardous Conditions actually brought to the Project by CONTRACTOR, CONTRACTOR's design consultants, subcontractors and suppliers or anyone for whose acts they may be or are liable. SCDOT is not responsible for negligent or willful acts by CONTRACTOR, CONTRACTOR's design consultants, subcontractors and

suppliers or anyone for whose acts they may be or are liable relating to Hazardous Conditions found at the site. CONTRACTOR shall indemnify, defend and hold harmless SCDOT and SCDOT's officers, directors, employees and agents from and against all claims, losses, damages, liabilities and expenses, including attorney's fees and expenses arising out of or resulting solely from those Hazardous Conditions actually brought to the Project or negligent or willful acts relating to Hazardous Conditions, or both by CONTRACTOR, CONTRACTOR's design consultants, subcontractors and suppliers or anyone for whose acts they may be or are liable.

XII. DEMOLITION, REMOVAL & DISPOSAL OF STRUCTURES

CONTRACTOR shall be responsible for the demolition, removal and disposal of all structures and their appurtenances within SCDOT Right of Way necessary for the completion of the Project, to include those portions which may extend outside the right of way, but were purchased as a part of the acquisition process. Structures shall include the bridges identified in the scope of work and all buildings acquired for the Project. All necessary permitting shall comply with Articles II.B.4 and IX of the Contract. Handling and disposal of Hazardous Conditions shall be in accordance with Article XI of the Contract. Before demolition of the structures, the CONTRACTOR shall complete and submit a Notification of Demolition and Renovation form to the South Carolina Department of Health and Environmental Control.

XIII. DIFFERING SITE CONDITIONS

A. “Differing Site Conditions” are defined as concealed or latent physical conditions at the Site that (i) materially differ from the conditions reasonably assumed to exist based on the information contained in the RFP, this Agreement and its Exhibits; or (ii) are of an unusual nature, differing materially from the conditions ordinarily encountered and generally recognized as inherent in the work. For this project, subsurface/geotechnical conditions WILL NOT be considered as a Differing Site Condition.

B. Upon encountering a Differing Site Condition, CONTRACTOR shall provide prompt written notice to SCDOT of such condition, which notice shall not be later than twenty (20) days after such condition has been encountered. CONTRACTOR shall provide such notice before the Differing Site Condition has been substantially disturbed or altered and before any work is performed.

C. Upon written notification, SCDOT will investigate the conditions and if it is determined that the conditions differ materially and cause an increase or decrease in the cost or time required for performance of the work, the Contract will be adjusted. No contract adjustment that results in a benefit to CONTRACTOR will be allowed unless CONTRACTOR has provided the required written notice.

XIV. FORCE MAJEURE

Delays or failures of performance shall not constitute breach of the Agreement if and to the extent such delays or failures of performance are caused by severe and not reasonably

foreseeable occurrences beyond the control of SCDOT or CONTRACTOR, including, but not limited to: Acts of God or the public enemy; expropriation or confiscation of facilities; compliance with any order or request of any governmental authority other than SCDOT or a party in privity with it; a change in law directly and substantially affecting performance of the Project; Acts of War; rebellion or sabotage or damages resulting there from; fires, floods, explosions, or extraordinary accidents; riots or strikes or other concerted acts of workman, whether direct or indirect, or any similar causes, which are not within the control of SCDOT or CONTRACTOR respectively, and which by the exercise of reasonable diligence, SCDOT or CONTRACTOR are unable to prevent. Any expense attributable to such occurrence shall not entitle CONTRACTOR to an adjustment in the Contract Price. Any critical path delay attributable to such an occurrence shall be added to the Contract Time.

XV. WARRANTY

A. CONTRACTOR warrants that it will perform all services in accordance with the standards of care and diligence normally practiced by recognized engineering and construction firms in performing services and obligations of a similar nature. CONTRACTOR warrants that all materials and equipment furnished shall be of good quality and new unless otherwise authorized by SCDOT and that the construction shall conform to the Contract requirements. CONTRACTOR agrees to promptly correct, at its own expense, defects or deficiencies in materials and workmanship that appear prior to and during a period of three (3) years after Final Completion of the Project. This shall include all plant-produced materials (i.e. asphalt, concrete, etc.). CONTRACTOR shall not be responsible for damages caused by SCDOT's failure to provide timely notification of potentially damaged or defective work of which SCDOT had actual knowledge. CONTRACTOR shall properly perform, at the written request of SCDOT made at any time within the warranty period after Final Completion of the Project as defined in Article IV.A.5, all steps necessary to satisfy the foregoing warranty and correct any element of the Project or the services that is defective or does not reflect such standards of care and diligence. The cost of such corrective services shall be CONTRACTOR's responsibility.

B. CONTRACTOR further warrants the performance of all bridge components on all structures for three (3) years from Final Completion of the Project. If a component fails to perform properly for any reason, including but not limited to normal wear and tear, the CONTRACTOR shall replace the failed component at no cost to SCDOT.

C. The warranty periods begin at Final Completion of the Project. CONTRACTOR shall immediately abate any warranty deficiency that poses an unsafe condition to the public; otherwise deficiencies shall be corrected no later than 30 days from the determination of corrective action. In the event CONTRACTOR, after notice, fails to immediately abate the deficiency or fails to make correction within the prescribed thirty (30) days, SCDOT may have the deficiency corrected. All costs associated with such correction by SCDOT shall be the responsibility of the CONTRACTOR and his Surety. With respect to any component that is repaired or replaced pursuant to this warranty, the warranty period of that component shall be the longer of one year from repair or replacement of the component or the remainder of the original warranty period.

D. CONTRACTOR shall take all steps necessary to transfer to SCDOT any manufacturer's or other third-party's warranties of any materials or other services used in the construction of the Project.

XVI. INDEMNITY

A. CONTRACTOR shall indemnify, defend and hold SCDOT harmless from any and all claims, liabilities and causes of action for any fines or penalties imposed on SCDOT by any state or federal agency because of violation by CONTRACTOR or any of its subcontractors of any state or federal law or regulation.

B. CONTRACTOR shall indemnify, defend and hold SCDOT harmless from any and all claims, liabilities and causes of action arising out of or resulting from, in whole or in part, the negligence or recklessness of CONTRACTOR or its agents, consultants and/or subcontractors.

XVII. TERMINATION AND CANCELLATION

A. Termination for Default

1. CONTRACTOR shall be in default of the Contract if it:

- a) Fails to supply a sufficient number of properly skilled workmen, tools, materials and equipment to assure the prompt completion of the work;
- b) Fails to perform work in accordance with contract requirements and/or refuses to remove or replace rejected materials or unacceptable work;
- c) Discontinues the prosecution of the work;
- d) Fails to resume work that has been discontinued within a reasonable time after notice to do so;
- e) Becomes insolvent or is declared bankrupt or commits any act of bankruptcy or insolvency;
- f) Allows any final judgment to remain unsatisfied for a period of 15 days;
- g) Makes an assignment for the benefit of creditors;
- h) Fails to maintain the Project schedule;
- i) Commits a substantial breach of the Contract; or
- j) For any other cause whatsoever, fails to carry on the work in an acceptable manner.

2. If CONTRACTOR does not commence work to cure the default within 15 days after receipt of written notice from SCDOT and thereafter diligently prosecute work to completion within a reasonable time as determined by SCDOT, then SCDOT will have full power and authority to terminate CONTRACTOR for default and shall provide written notification of the termination to CONTRACTOR and Surety.

3. Upon termination for default, Surety will have the right to complete the contract and shall be given thirty (30) days, or longer in SCDOT's discretion, in which to resume the work. This procedure shall not in any way serve to extend the contract time. All charges incident to negotiation with the Surety and arranging for work to be resumed, including attorney's fees, shall be charged against CONTRACTOR or Surety as part of the cost of the work.

4. If Surety refuses to complete the work or fails to take over the work promptly as provided by this Agreement, then SCDOT may appropriate or use any or all materials and equipment on the job site as may be suitable and acceptable and may enter into an agreement for the completion of the Contract. All costs and charges incurred by SCDOT together with the cost of completing the work under the Contract will be deducted from any monies due or which may become due CONTRACTOR. If such expense exceeds the sum which would have been payable under the Contract, CONTRACTOR and Surety shall be liable and shall pay to SCDOT the amount of such excess.

5. Upon termination for default, all Project Documents, as defined in Article II.E, shall be surrendered forthwith by CONTRACTOR to SCDOT. SCDOT will be authorized to use the Project documents for the sole purpose of promoting, completing, using, maintaining, upgrading or adding to the Project. This authorization includes allowing design professionals to make changes, corrections, or additions to the Project documents for these purposes.

6. If, after termination, it is determined that the Contractor was not in default, or that the default was excusable, the rights and obligations of the parties shall be the same as if the termination had been issued for the convenience of the State.

B. Termination for Convenience

1. SCDOT reserves the right to cancel the Work upon ten (10) days written notice to CONTRACTOR. Should the Work be so canceled by SCDOT for convenience, CONTRACTOR shall be paid for the value of the Work, based upon the Schedule of Values, performed to the date of cancellation and demobilization together with any cancellation charges by vendors and subcontractors. CONTRACTOR shall also be entitled to the cost of securing the work, provided such cost is approved by SCDOT. In no event, however, shall the total payment to CONTRACTOR pursuant to such a cancellation exceed the Contract Price.

2. Termination of all or a portion of the Contract shall not relieve CONTRACTOR of any responsibility it would otherwise have for the work completed, or for any claims arising from that work.

3. Upon such termination, all Project Documents, as defined in Article II.E, shall be surrendered forthwith by CONTRACTOR to SCDOT. SCDOT will be authorized to use the Project documents for the sole purpose of promoting, completing, using, maintaining, upgrading or adding to the Project. This authorization includes allowing design professionals to make changes, corrections, or additions to the Project documents for these purposes.

XVIII. DISADVANTAGED BUSINESS ENTERPRISES

A. DBE Goal - The DBE goal on this Project is nine percent (9.0 %) of the Contract Price. CONTRACTOR shall comply with the requirements of the SCDOT DBE – Design Build Special Provision, attached hereto in Exhibit 5, and the SCDOT DBE Supplemental Specification. CONTRACTOR is required to submit a DBE Utilization Plan within thirty (30) calendar days of execution of the Agreement in accordance with the requirements of the DBE Special Provision, which shall include, but not be limited to, the designation of a DBE liaison officer who will be assigned the responsibility of administering and promoting an active and inclusive DBE Program as required by 49 CFR Part 26, DBE Special Provision and DBE Supplemental Specification. CONTRACTOR's DBE liaison shall provide SCDOT with updated DBE Committal Sheets, signed quotes, and executed subcontracts in accordance with the approved DBE Utilization Plan. The Final Committal Sheet, signed quotes and executed subcontracts shall be submitted to the SCDOT within 90 calendar days from the Notice to Proceed.

B. Copies of DBE Contracts - CONTRACTOR shall provide SCDOT with copies of executed DBE contracts, including the name of the DBE firm, the name of the subcontractor, if any, for whom the DBE will work, the amount of the contract, the type of work to be performed, and an estimated schedule of DBE performance.

C. Monthly Subcontractor Expenditure Records - CONTRACTOR shall provide SCDOT a monthly report showing amounts paid to subcontractors on the Project. The report shall provide a running total of amounts paid to subcontractors on the Project, including the name of each subcontractor paid, the amount paid to each in that month, and the cumulative amount paid to each as of the date of the report. The report shall also indicate whether the subcontractor is a DBE or non-DBE firm.

D. SCDOT'S Right to Audit - SCDOT will have the right to audit all documentation regarding DBE participation in the Project.

E. Nondiscrimination - CONTRACTOR, or subcontractor, shall not discriminate on the basis of race, color, national origin, or sex in the performance of this contract. CONTRACTOR shall carry out applicable requirements of 49 CFR Part 26 in the award and administration of SCDOT assisted contracts. Failure by CONTRACTOR to carry out these

requirements is a material breach of this contract, which may result in the termination of this contract or such other remedy, as SCDOT deems appropriate.

XIX. ON-THE-JOB TRAINING REQUIREMENTS

There is an On-The-Job Training Requirement for this Project. The number of persons to be trained under the On-the-Job Training Program during this Project is one (1) for Bridge and four (4) for Road. The CONTRACTOR shall comply with the requirements of the Federal-Aid Provisions Project Supplemental Specifications attached hereto as **EXHIBIT 6** as well as the Specific Equal Employment Opportunity Responsibilities Training Special Provisions within the Federal Aid Supplemental Specifications. The CONTRACTOR shall submit its plan for On-the-Job Training to SCDOT for written approval prior to commencing construction activities.

XX. RECORD RETENTION

A. CONTRACTOR shall maintain the following documents for a period of three (3) years or a period equal to the warranty period, whichever is longer, after Final Completion of the Project:

1. All CONTRACTOR samples and test reports;
2. Daily Diaries (substantially in the form of SCDOT's form 647, as revised 7/95);
3. Any other documents required to be retained in accordance with the Quality Control Plan.

B. During the retention period, SCDOT will be granted access to those documents upon reasonable notice. At any time during the retention period, SCDOT will have the option of taking custody of the documents. CONTRACTOR shall obtain a written release from SCDOT prior to destroying the records after the retention period.

XXI. AS-BUILTS

A. In addition to those documents set forth elsewhere in this Agreement, CONTRACTOR shall provide to SCDOT prior to Final Completion, complete sets of as-built drawings (See Article XXI.D for details). As-built plans consist of the final version of the design plan CADD drawings that incorporate all changes, including any adjustments, relocations, additions and deletions that occurred during construction. CONTRACTOR shall certify that the as-built plans are a true and correct representation of the work as constructed. If any design changes occur during construction, the plan sheets (or any other "job site record document" with a seal) revised after award of contract shall include a complete accounting and detail of the revisions and design changes. The P.E. responsible for the revisions shall seal each altered plan sheet (or any other "job site record document" with a seal). This documented information is to be part of the As-Built Plan requirements. The CONTRACTOR shall develop as-built plans in

accordance with the SCDOT Manual of Instructions for the Preparation of As-Built Plans, latest edition.

B. Information regarding major revisions to the plans shall be noted in a revision box on the plans. The information listed in the revision box shall include: the initiator of the revision, a brief explanation of the nature of the revision, and acceptance and approval from CONTRACTOR, along with associated dates.

C. In addition to the revisions that incorporated changes during construction, the as-built plans shall include the following information gathered during construction:

1. The location and elevation of foundations remaining below grade.
2. The final profile of each bridge constructed. The profile shall include the elevation along the centerline (or as specified by SCDOT) and a line three feet inboard of each gutter line. Points on the profile shall be taken at no greater than 25-foot intervals and shall include the beginning and end of each span.
3. If any structure has pile foundations, information concerning the pile driving operation shall be listed to include pile and driving equipment data, final pile bearing, elevation of pile tip when plan bearing was obtained, final pile tip elevation, penetration into the ground, and PDA or WEAP analysis data. This information shall be entered on each footing or bent sheet, or be included as a new sheet inserted immediately following the pertinent footing or bent sheet.
4. If any structure has drilled shaft foundations, information concerning the installation of the shaft shall be listed to include the drilled shaft report. This information shall be entered on each footing or bent sheet, or be included as a new sheet inserted immediately following the pertinent footing or bent sheet.
5. The final horizontal location of all existing and relocated utility lines and structures that are within the right-of-way. Include approved Utility Agreements, No Cost/No Conflict Letters, and Encroachment Permits.
6. The final location of all pipes, culverts, and drainage structures.
7. To include all right-of-way revisions, permissions, and an updated right-of-way data sheet to show the date and manner of acquisition of each tract

D. As-built plans shall be submitted as two (2) full size (36 inch x 22 inch) copies and one (1) copy on compact disc in a format acceptable to SCDOT. The levels and symbology of the as-built CADD drawings shall conform to SCDOT standard levels and symbology used to develop the design drawings for the Project.

XXII. ESCROW PROPOSAL DOCUMENTS

A. Scope and Purpose

The purpose of this article is to preserve the proposal documents of the successful proposer (CONTRACTOR) for use by the parties in any claims or litigation between SCDOT and CONTRACTOR arising out of this contract.

CONTRACTOR shall submit a legible copy of proposal documentation used to prepare the Technical and Cost Proposal for this contract to SCDOT. Such documentation shall be placed in escrow with a banking institution or other bonded document storage facility and preserved by that institution/facility as specified in the following sections of this specification.

B. Proposal Documentation

The term "proposal documentation" as used in this specification means all writings, working papers, computer print outs, charts, and all other data compilations which contain or reflect information, data, and calculations used by CONTRACTOR to prepare the technical and cost proposal in proposing for the Project. The term "proposal documentation" includes, but is not limited to, equipment rates, overhead rates, labor rates, efficiency or productivity factors, arithmetic extensions, and quotations from subcontractors and material suppliers to the extent that such rates and quotations were used by CONTRACTOR in preparing, formulating and determining the technical and cost proposal. The term "proposal documentation" also includes any manuals that are standard to the industry used by CONTRACTOR in determining the proposal for the Project. Such manuals may be included in the proposal documentation by reference. Such reference shall include the name and date of the Publication and the Publisher. The term does not include proposal documents provided by SCDOT for use by CONTRACTOR in proposing on the Project.

C. Submittal of Proposal Documentation

CONTRACTOR shall submit the proposal documentation to SCDOT, in a container suitable for sealing, no later than ten calendar days following award of the Contract by SCDOT. CONTRACTOR will not be allowed to begin work until the acceptable documentation has been received. The container shall be clearly marked "Proposal Documentation" and shall also show on the face of the container CONTRACTOR's name, the date of submittal, the File Number, and the Project Name.

D. Alternative Delivery Method

CONTRACTOR may elect to use a delivery service to escrow the proposal documents directly with the escrow agent/facility as required under this Article. A delivery service with a tracking system such as FedEx, UPS, or DHL shall be used by the CONTRACTOR under this method of delivery. To affect delivery, CONTRACTOR is required to comply with the delivery procedures set forth under ~~special provision~~ the Supplemental Specification entitled ~~Procedures to Escrow Bid Documentation by Delivery Service, dated November 1, 2013, attached hereto as EXHIBIT 7~~. For purposes of this Agreement, the term

bid documentation used in the special provision has the same meaning as proposal documentation in Section B above.

E. Affidavit

In addition to the proposal documentation, an affidavit, signed under oath by an individual authorized by CONTRACTOR to execute contracts shall be included. The affidavit shall list each proposal document with sufficient specificity so a comparison may be made between the list and the proposal documentation to ensure that all of the proposal documentation listed in the affidavit has been enclosed. The affidavit shall attest the following:

1. The affiant has personally examined the proposal documentation,
2. The affidavit lists all of the documents used by CONTRACTOR to determine the proposal for the Project, and
3. All such proposal documentation has been included.

F. Verification

Upon receipt of the proposal documentation, authorized representatives of SCDOT and CONTRACTOR will verify the accuracy and completeness of the proposal documentation compared to the affidavit. Should a discrepancy exist, CONTRACTOR shall immediately furnish SCDOT with any other needed proposal documentation. SCDOT, upon determining that the proposal documentation is complete, will, in the presence of CONTRACTOR's representative, immediately place the complete documentation and affidavit in the container and seal it. Both parties will deliver the sealed container to a banking institution or other bonded document storage facility selected by SCDOT for placement in a safety deposit box, vault or other secure accommodation.

G. Duration and Use

The proposal documentation and affidavit shall remain in escrow during the life of the Contract or until such time as CONTRACTOR files a claim or initiates litigation against SCDOT related to the contract. Receipt of CONTRACTOR's claim, or litigation against SCDOT, shall be sufficient evidence for SCDOT to obtain the release and custody of the proposal documentation. If no such claim is received or litigation initiated, the Final Estimate has been paid and the warranty period for the Contract has expired, SCDOT shall instruct the banking institution or other bonded document storage facility to release the sealed container to CONTRACTOR using the form provided in **EXHIBIT 7**.

CONTRACTOR agrees that the sealed container placed in escrow contains all of the proposal documentation used to determine the proposal and that no other proposal documentation shall be utilized by CONTRACTOR in litigation over claims brought by CONTRACTOR arising out of this contract.

H. Refusal or Failure to Provide Proposal Documentation

Refusal of CONTRACTOR to provide adequate documentation will be considered material breach of the Contract and CONTRACTOR will be declared in default of the Contract. SCDOT may, at its option, terminate the contract for default. These remedies are not exclusive and SCDOT may take such other action as is available to it under the law.

I. Confidentiality of Bid Documentation

The proposal documentation and affidavit in escrow are, and will remain, the property of CONTRACTOR. SCDOT has no interest in, or right to, the proposal documentation and affidavit other than to verify the contents and legibility of the proposal documentation unless a claim is received or litigation ensues between SCDOT and CONTRACTOR. In the event of such claim or litigation, the proposal documentation and affidavit shall become the property of SCDOT.

J. Cost and Escrow Instructions

The cost of escrow will be borne by SCDOT. SCDOT will provide escrow instructions to the banking institution or other bonded document storage facility consistent with this article.

K. Escrow Agreement

CONTRACTOR agrees that it will sign an Escrow Agreement with SCDOT and the escrow agent consistent with this article. Should CONTRACTOR fail to sign the Escrow Agreement, when presented, CONTRACTOR may be declared in default of the Contract. The Escrow Agreement is attached in **EXHIBIT 7**.

L. Payment

There will be no separate payment for compilation of the data, container or cost of verification of the proposal documentation. All cost shall be included in the overall Contract Price.

XXIII. DISPUTE RESOLUTION

A. Each party hereby waives a trial by jury regarding any dispute between them arising out of this Contract and any such trial will be a non-jury trial before the South Carolina Circuit Court in Richland County.

B. In the event of a dispute between the parties, it shall be a condition precedent to litigation that the parties submit the dispute to the Standing Dispute Review Board pursuant to the Claims Procedure set forth in the Project Supplemental Specifications.

C. CONTRACTOR consents that any papers, notices, or process necessary or proper for the initiation or continuation of any disputes, claims, or controversies relating to the

Agreement; for any court action in connection therewith; or for the entry of judgment on any award made, may be served on CONTRACTOR by certified mail (return receipt requested) addressed to CONTRACTOR at the address provided in Article XXVI. Notice by certified mail is deemed duly given upon deposit in the United States mail.

XXIV. SCDOT'S AGENT

SCDOT will appoint an individual who will be authorized to act on behalf of SCDOT, with whom CONTRACTOR may consult at all reasonable times, and whose instructions and decisions will be binding upon SCDOT as to all matters pertaining to this Agreement and the performance of the parties hereunder.

XXV. ASSIGNABILITY

The Contract shall not be assignable by CONTRACTOR without the prior written consent of SCDOT. SCDOT may assign the Contract without the consent of CONTRACTOR.

XXVI. GENERAL PROVISIONS

A. This Agreement shall be governed by and interpreted in accordance with the substantive laws of the State of South Carolina.

B. Headings and titles of the various parts of this Agreement are for convenience of reference only and shall not be considered in interpreting the text of this Agreement. Modifications or amendments to this Agreement must be in writing and executed by duly authorized representatives of each party.

C. In the event that any portion or all of this Agreement is held to be void or unenforceable, the parties agree to negotiate in good faith to reach an equitable agreement which shall affect the intent of the parties as set forth in this Agreement.

D. All notices pertaining to this Agreement shall be in writing and, if to SCDOT, will be sufficient when sent registered or certified mail to SCDOT addressed as follows:

Deputy Secretary for Engineering
South Carolina Department of Transportation
Post Office Box 191
Columbia, South Carolina 29202-0191

All notices to CONTRACTOR shall be sufficient when sent registered or certified mail to CONTRACTOR addressed as follows:

(Insert CONTRACTOR'S address here)

E. The Contract Documents set forth the full and complete understanding of the parties as of the Effective Date defined herein, and supersedes any and all agreements and representations made or dated prior thereto.

F. The parties make no representations, covenants, warranties or guarantees, express or implied, other than those expressly set forth herein. The parties' rights, liabilities, responsibilities and remedies within respect to the work shall be exclusively those expressly set forth in this Agreement.

G. In no event shall any failure by either party hereto to fully enforce any provision to this Agreement be construed as a waiver by such party of its right to subsequently enforce, assert or rely upon such provision.

H. Nothing in this Agreement is intended to create any contract rights for any party other than SCDOT and CONTRACTOR, nor are any third-party beneficiary rights intended to be created hereby.

IN WITNESS WHEREOF, the parties hereto have executed this Agreement as of the Effective Date defined herein. The Effective Date is defined as the date signed by the Director of Construction on behalf of South Carolina Department of Transportation.

Witnesses:

Date: _____

Witnesses:

SOUTH CAROLINA DEPARTMENT
OF TRANSPORTATION

By: _____
Todd Steagall, P.E.
Director of Construction

Recommended:

Jeff Elliott, P.E.
Contract Administration Engineer

CONTRACTOR

Name of Contractor

By: _____

Its: _____

CERTIFICATION OF CONTRACTOR

I hereby certify that I am the duly authorized representative of CONTRACTOR and that neither I nor the above CONTRACTOR I here represent has:

- a) employed or retained for a commission, percentage, brokerage, contingent fee, or other consideration, any firm or person (other than a bona fide employee working solely for me or the above CONTRACTOR) to solicit or secure this contract;
- b) agreed, as an express or implied condition for obtaining this contract, to employ or retain the services of any firm or person in connection with carrying out the contract, or
- c) paid, or agreed to pay, to any firm, organization or person (other than a bona fide employee working solely for me or the above CONTRACTOR) any fee, contribution, donation, or consideration of any kind for, or in connection with, procuring or carrying out the contract except as here expressly stated (if any);
- d) either directly or indirectly, entered into any agreement, participated in any collusion, or otherwise taken any action, in restraint of free competitive bidding in connection with the submitted proposal.

By execution of this Agreement, CONTRACTOR certifies CONTRACTOR and all CONTRACTOR’s consultants, sub-consultants, contractors, employees and agents will comply with South Carolina’s Ethics, Government Accountability, and Campaign Reform Act of 1991, as amended. The following statutes require special attention: (a) Offering, giving, soliciting, or receiving anything of value to influence action of public employee - §8-13-790, 8-13-705, 8-13-720; (b) Recovery of kickbacks - §8-13-790, (c) Offering, soliciting or recovering money for advice or assistance of public official - §8-13-720, (d) Use or disclosure of confidential information - §8-13-725, (e) Persons hired to assist in the preparation of specifications or evaluation of bids - §8-13-1150, (f) Solicitation of state employees - §8-13-755, 8-13-760 and §8-13-725, (g) False Claims Act -§16-13-240. The state may rescind any contract and recover all amounts expended as a result of any action taken in violation of this provision.

I acknowledge that this certificate is to be furnished to the Department, the Federal Highway Administration, and the U. S. Department of Transportation, and is subject to applicable State and Federal laws, both criminal and civil.

I acknowledge that giving false, misleading, or incomplete information on this certification may subject me to prosecution under Section 16-9-10 of the South Carolina Code of Laws.

CONTRACTOR

Name of Contractor

By: _____

Date: _____

Its: _____

CERTIFICATION OF DEPARTMENT

I hereby certify that I am the Director of Construction for the South Carolina Department of Transportation (SCDOT) of the State of South Carolina and that the above CONTRACTOR or its representative has not been required, directly or indirectly, as an express or implied condition in connection with obtaining or carrying out this agreement to:

- (a) employ or retain, or agree to employ or retain, any firm or person, or
- (b) pay, or agree to pay, to any firm, person, or organization, any fee, contributions, donations, or consideration of any kind, except as here expressly stated (if any).

I acknowledge that this certificate is to be furnished to the Federal Highway Administration, and U. S. Department of Transportation, and is subject to applicable State and Federal laws, both criminal and civil.

SOUTH CAROLINA DEPARTMENT OF
TRANSPORTATION

BY: _____

TITLE: DIRECTOR OF CONSTRUCTION

Date: _____

DRUG-FREE WORKPLACE CERTIFICATION

In accordance with Section 44-107-30, South Carolina Code of Laws (1976), as amended, and as a condition precedent to the execution of this agreement, the undersigned, who is an authorized representative of the CONTRACTOR certifies on behalf of the CONTRACTOR that the PROPOSER will provide a drug-free workplace by:

- (1) publishing a statement notifying employees that the unlawful manufacture, distribution, dispensations, possession, or use of a controlled substance is prohibited in the CONTRACTOR's workplace and specifying the actions that will be taken against employees for violations of the prohibition;
- (2) establishing a drug-free awareness program to inform employees about:
 - (a) the dangers of drug abuse in a workplace;
 - (b) the person's policy of maintaining a drug-free workplace;
 - (c) any available drug counseling, rehabilitation, and employee assistance programs; and
 - (d) the penalties that may be imposed upon employees for drug violations;
- (3) making it a requirement that each employee to be engaged in the performance of the agreement be given a copy of the statement required by item (1);
- (4) notifying the employee in the statement required by item (1) that, as a condition of employment of this agreement, the employee will:
 - (a) abide by the terms of the statement; and
 - (b) notify the employer of any criminal drug statute conviction for a violation occurring in the workplace no later than five days after the conviction;
- (5) notifying the South Carolina Department of Transportation within ten days after receiving notice under item (4)(b) from an employee or otherwise receiving actual notice of the conviction;
- (6) imposing a sanction on, or requiring the satisfactory participation in a drug abuse assistance or rehabilitation program by, any employee convicted as required in Section 44-107-50; and
- (7) making a good faith effort to continue to maintain a drug-free workplace through implementation of items (1), (2), (3), (4), (5), and (6)

By execution of this Agreement CONTRACTOR certifies CONTRACTOR and all CONTRACTOR's consultants, sub-consultants, contractors, employees and agents will comply with all applicable provisions of the Drug-Free Workplace Act, Title 44, Chapter 107 of the South Carolina Code of Laws, as amended.

CONTRACTOR: _____
(Signature)

EXHIBIT 1

COST PROPOSAL BID FORM

PROPOSED COST PROPOSAL BID FORM
FOR
WIDENING AND REHABILITATION OF I-77
FROM MM 15 TO MM 27
RICHLAND COUNTY

The Cost Proposal Bid Form, as submitted by the selected PROPOSER, will be included with the completed agreement.

EXHIBIT 2

SCHEDULE OF VALUES

SCHEDULE OF VALUES
FOR
INTERSTATE 77 WIDENING AND REHABILITATION
FROM MM 15 TO MM 27
RICHLAND COUNTY

A Schedule of Values, submitted by the selected PROPOSER and approved by SCDOT, will be included with the completed agreement.

EXHIBIT 3

SCOPE OF WORK

1. Project Summary

This Project consists of widening northbound and southbound I-77 in Richland County with one (1) additional lane in each direction beginning between SC 12 (Percival Road) and I-20 and terminating near the S-52 (Killian Road) interchange. The project also includes interstate rehabilitation along southbound I-77 from Percival Road to S-59 (Blythewood Road) and interstate rehabilitation along northbound I-77 from Percival Road to Killian Road. The pavement for the Project consists of both concrete and asphalt. The CONTRACTOR shall complete the work in accordance with the Agreement and all subsequent exhibits. ~~At the specified locations referenced to the existing I-77 plans provided in Attachment B, the Project includes, but is not limited to, the following general items that are further detailed in subsequent exhibits:~~ The following is a list of major construction items involved in the Project. This list is not intended to comprise all components of the Project nor is it intended to be a complete description of the criteria for each item required. For a full understanding of the scope of the Project and the criteria of the construction items needed for this Project, please review Exhibit 4.

I-77 Mainline Southbound from Station 1160+00 (approx. MM 14.9) to 1170+00 (approx. MM 15):

- extend/install new guardrail at locations that do not meet current standards
- Pave under guardrail adjacent to paved shoulders

I-77 Mainline Northbound & Southbound from Station 1170+00 (approx. MM 15.0) to 1302+50 (approx. MM 17.5):

- Remove existing paved shoulders in median and add one (1) travel lane with paved shoulder toward the median in each direction
- Mill existing lanes and overlay with HMA and OGFC
- Overlay existing ramps with HMA
- Adjust existing ramp tapers, gores, and storage lanes
- Adjust ~~and~~ or improve shoulders, side slopes, ditch banks and paved ditches ~~and rehabilitate or reconstruct paved ditches~~
- Replace damaged and/or substandard guardrail ~~and extend/install new guardrail and concrete bridge pier protection at locations that do not meet current standards~~
- Pave under guardrail adjacent to paved shoulders
- Install new median cable barrier
- Widen and repair existing I-77 mainline bridges
- Install milled-in rumble strips
- Install new and/or upgrade signing and pavement markings
- Repair, ~~and/or~~ replace, ~~or increase capacity of~~ stormwater drainage systems ~~appurtenances~~

EXHIBIT 3 – SCOPE OF WORK

- Provide or improve clear zone, sight distance, and roadside safety Clearing and improving I-77 clear zone
- Re-install signal loop detectors that are damaged by construction along ramps
- Retain the existing vegetated buffer along the west side of southbound I-77 from approximate STA 1178+00 to 1183+00

I-77 Mainline Northbound & Southbound from Station 1302+50 (approx. MM 17.5) to 1510+00 (approx. MM 21.5):

- Remove existing paved shoulders in median and add one (1) travel lane with paved shoulder towards the median in each direction
- Patch existing concrete lanes and/or paved shoulders in various locations
- Overlay existing concrete pavement with HMA and OGFC
- Overlay existing ramps with HMA
- Cross Slope Verification/Correction
- Adjust existing ramp tapers, gores, and storage lanes
- Adjust and/or improve shoulders, side slopes, ditch banks and paved ditches and rehabilitate or reconstruct paved ditches
- Replace damaged and/or substandard guardrail and extend/install new guardrail and concrete bridge pier protection at locations that do not meet current standards Install new guardrail
- Pave under guardrail adjacent to paved shoulders
- Install new median cable barrier
- Widen and repair existing I-77 mainline bridges
- Repair and/or replace control of access fencing
- Install new and/or reset existing signing and install new pavement markings
- Repair, and/or replace, or increase capacity of stormwater drainage systems appurtenances
- Provide or improve clear zone, sight distance, and roadside safety Clearing and improving I-77 clear zone
- Re-install signal loop detectors that are damaged by construction along ramps
- Install milled-in rumble strips

I-77 Mainline Southbound from Station 1510+00 (approx. MM 21.5) to 1801+15 (approx. MM 27.0):

- Patch existing concrete lanes and/or shoulders in various locations
- Overlay existing lanes with HMA and OGFC
- Overlay existing ramps with HMA
- Cross Slope Verification/Correction

EXHIBIT 3 – SCOPE OF WORK

- Adjust ~~and~~ or improve shoulders, side slopes, ditch banks and paved ditches **and rehabilitate or reconstruct paved ditches**
- Replace damaged and/or substandard guardrail **and extend/install new guardrail and concrete bridge pier protection at locations that do not meet current standards**
~~Install new guardrail~~
- Pave under guardrail adjacent to paved shoulders
- ~~Install new median cable barrier~~
- Repair existing I-77 mainline bridge deck
- Repair **and/or replace** control of access fencing
- Install new pavement markings
- **Where the work requires existing pipes to be extended,** repair and/or replace storm drainage appurtenances
- **Provide or improve clear zone, sight distance, and roadside safety** ~~Clearing and improving I-77 clear zone~~
- Re-install signal loop detectors **that are damaged by construction along ramps**
- **Install milled-in rumble strips**

The Project includes widening and rehabilitation of the following ten (10) bridges and approach/transitional slabs:

- I-77 Northbound and Southbound Overpasses over I-20 & I-20 Ramp (two (2) bridges)
- I-77 Northbound and Southbound Overpasses over I-77 Ramp E (File 40.835.6 in existing plans) (two (2) bridges)
- I-77 Northbound and Southbound Overpasses over Windsor Lake Boulevard (S-1196) (two (2) bridges)
- I-77 Northbound and Southbound Bridges over Windsor Lake (two (2) bridges) **and replacement of one (1) approach slab**
- I-77 Northbound and Southbound Overpasses over Little Jackson Creek/Edgewater Drive (S-1722) (two (2) bridges) **and replacement of all transitional slabs**

The Project includes repair/rehabilitation of the following bridge deck **and replacement of transitional slabs:**

- I-77 Southbound Overpass over US 21 (one (1) bridge)

EXHIBIT 4

PROJECT DESIGN CRITERIA

EXHIBIT 4 – PROJECT DESIGN CRITERIA

This exhibit details the criteria by which the project shall be designed and constructed. These criteria are divided into subsections as listed below:

Exhibit 4a – Roadway

Exhibit 4b – Structures

Exhibit 4c – Pavement

Exhibit 4d – Traffic

Part 1 – Signing and Pavement Markings

Part 2 – Work Zone Traffic Control

Part 3 – Traffic Signals

Part 4 – Intelligent Transportation System

Exhibit 4e – Hydraulics

Exhibit 4f – Geotechnical

Exhibit 4g – Environmental

DESIGN REFERENCES

This exhibit describes the general design considerations and criteria for the proposed roadway approaches, hydraulics, structures, and surveys.

Design standards shall be in accordance with the following design references as supplemented or amended by Sections 4a, 4b, 4c, 4d, 4e, 4f, and 4g of this Exhibit. Any variation in design from the included information shall require written approval from SCDOT.

- SCDOT Pre-Construction Survey Manual, effective as of the Final RFP release date
- 2003 SCDOT Highway Design Manual with updates effective as of the Final RFP release date and supplemented with AASHTO A Policy on Geometric Design of Highways and Streets, 2001
- AASHTO A Policy on Design Standards Interstate System, 2005
- AASHTO Roadside Design Guide, with 2006 Chapter 6 update, 3rd Edition
- AASHTO Standard Specifications for Highway Bridges, 17th Edition
- SCDOT Standard Drawings, effective as of the Final RFP release date
- SCDOT Engineering Directives, effective as of the Final RFP release date
- SCDOT Preconstruction Design Memorandum, effective as of the Final RFP release date
- SCDOT Instructional Bulletins, effective as of the Final RFP release date
- AASHTO Guide for the Development of Bicycle Facilities, 1999
- AASHTO Guide for the Planning, Design, and Operation of Pedestrian Facilities, 2004
- SCDOT Americans with Disabilities Act Transition Plan, January 2009
- United States Access Board’s Revised Draft Guidelines for Accessible Public Rights-of-Way (PROWAG), November 23, 2005
- SCDOT Roadside Plants to Avoid/Trees with Limitations on R/W, October 2014
- SCDOT Access and Roadside Management Standards, August 2008 with updates
- SCDOT Plan Preparation Guide, 2000
- SCDOT Standard Specifications for Highway Construction, 2007
- SCDOT Supplemental Specifications (2007), effective as of the Final RFP release date
- SCDOT Supplemental Technical Specifications, effective as of the Final RFP release date
- SCDOT Qualified Product Lists, effective as of the Final RFP release date
- SCDOT Road Design Reference Material for Consultant Prepared Plans, June 2010
- FHWA Manual on Uniform Traffic Control Devices, 2009
- SCDOT Supplement to the MUTCD
- The Rule on Work Zone Safety and Mobility
- SCDOT Procedures and Guidelines for Work Zone Traffic Control Design
- SCDOT Traffic Signal Design Guidelines, 2009 with updates
- Traffic Signal Material Specifications, effective as of the Final RFP release date
- Traffic Signal Supplemental Specifications, effective as of the Final RFP release date
- Highway Capacity Manual, 2010
- AASHTO “Standard Specifications for Structural Supports for Highway Signs, Luminaires and Traffic Signals”, effective as of the Final RFP release date

EXHIBIT 4 – PROJECT DESIGN CRITERIA

- SCDOT Preconstruction Advisory Memorandums, effective as of the Final RFP release date
- SCDOT Bridge Design Manual, 2006
- SCDOT Bridge Design Memoranda, effective between July 1, 2006 and the Final RFP release date
- 2012 AASHTO LRFD Bridge Design Specifications, Sixth Edition (with 2013 Interim Revisions)
- SCDOT Geotechnical Design Manual, 2010 Edition (Version 1.1)
- SCDOT Seismic Design Specifications for Highway Bridges, 2008 (Version 2.0)
- SCDOT Bridge Drawings and Details, effective as of the Final RFP release date
- AASHTO/AWS D1.5M/D1.5:2010 Bridge Welding Code, with 2011 interims
- SCDOT Pavement Design Guidelines, July 2008 Edition
- SCDOT Requirements for Hydraulic Design Studies, May 2009
- SCDOT Stormwater Quality Design Manual, effective as of the Final RFP release date;
- AASHTO “Highway Drainage Guidelines”, 2007
- AASHTO “Drainage Manual”, 2014 first edition
- FEMA Regulations, 44CFR Chapter 1
- The State Stormwater and Sediment and Erosion Control Regulations administered by DHEC, 26 S.C. Code Ann. Regs. 72-405 (Supp. 1995) et seq.
- South Carolina State Water Law
- SCDHEC NPDES MS4 Permit # SCS040001
- SCDHEC NPDES Construction Permit # SCR160000

EXHIBIT 4a

ROADWAY DESIGN CRITERIA

1.0 GENERAL

The Contractor shall prepare the roadway geometric design for the project using the design standards and criteria that are most appropriate based on design speed, functional classification, design traffic volumes, right-of-way, and aesthetics. The design elements shall include, but not be limited to, the horizontal and vertical alignments, lane widths, shoulder widths, median widths, sight distance, clear zone, cross slopes, and side slopes. ~~The geometric design developed by the Contractor shall be an engineering solution that is not merely an adherence to the minimum SCDOT and/or AASHTO standards.~~

2.0 CRITERIA

2.1 Design Speed & Functional Classification

Interstate 77 shall be designed as a principal arterial freeway with rolling terrain classification. A WB-62 design vehicle shall be utilized for all geometric design.

Interstate 77

Begin (Station 1160+00 1170+00) to Station 1188+64-1240+00 60 mph (Meet or Exceed)

Station 1188+64-1240+00 to End (Station 1801+15) 70 mph (Meet or Exceed)

Interchange Ramps

Ramps	45 mph (Meet or Exceed)
Loops	25 mph (Meet or Exceed)

2.2 Pavement, Shoulder & Median Width

Pavement, shoulder, and median widths shall be developed in compliance with SCDOT Highway Design Manual Chapters 9, 13, 16, and 19.

- Through Lanes 12 ft.
- Shoulder (outside) 10 ft. paved/12 ft. total width
- Shoulder (inside) 10 ft. paved/12 ft. total width

Add 3.5 ft. to shoulder width when guardrail is required. Pave entire shoulder width when adjacent to guardrail/concrete barrier.

2.3 Horizontal Curves

Horizontal curves and superelevation shall be developed in compliance with SCDOT Highway Design Manual Chapter 11 and the SCDOT Standard Drawing No. 150-205-00.

2.4 Vertical Curves, Grades, and Clearances

Vertical curves, grades, and clearances shall be developed in compliance with SCDOT Highway Design Manual Chapters 12, 16, and 19 through 22. Grade adjusted K values shall be considered where the grades are 3 percent or greater.

Spline grade shall not be used.

2.5 Side Slopes

Side slopes shall be developed in compliance with SCDOT Highway Design Manual Chapters 13, 14, 16, and 19.

2.6 Cross Slopes

Cross slopes shall be developed in compliance with SCDOT Highway Design Manual Chapters 11, 13, 16, and 19.

- Shoulder (paved) 2' or less Match **travelway** pavement slope
- Shoulder (paved) greater than 2' 24:1
- Shoulder (unpaved) 12:1

Paved shoulder on high side of superelevation will continue the travelway cross slope.

Paved shoulder on low side of superelevation will maintain a 24:1 slope until the superelevation slope exceeds a 24:1 slope. The shoulder then will be sloped at the superelevation rate.

2.7 Clear Zones

~~A crash analysis has been performed for this section of I-77. The clear zone for I-77 mainline shall be 46' for the entire length of project.~~

Mainline Interstate, Collector / Distributor Road, and Ramps

The SCDOT HDM (2003 with updates) Chapter 14 and the *Roadside Design Guide* (AASHTO) edition 2006 with Chapter 6 Update, 3rd Edition shall be used based on traffic volumes, design speed, and slopes. Clear Zones provided in Figure 14.3A in the SCDOT HDM (2003 with updates) shall not be limited to 30 feet as indicated as a possibility in the footnote for this figure. When a range of values is shown; the higher value shall be selected. Also, SCDOT does not typically use a 3H:1V fill slope. See the *Roadside Design Guide* (AASHTO) edition 2006 with Chapter 6 Update, 3rd Edition for clear zone calculations where a 3H:1V fill slope is used. Use 3H:1V fill slope only where fill heights are required to match existing conditions and clear zone can be obtained within the Project limits.

For those areas where no guardrail currently exists, the Contractor shall design fill and cut slopes to obtain clear zones and to avoid the need for protection. In areas

where new right-of-way, wetland impacts, or impacts to frontage roads or immovable obstructions would be a result of achieving the clear zone requirement, substandard areas may be protected.

Where existing fill and cut slopes are presently protected by guardrail, the Contractor shall replace damaged and/or substandard guardrail and extend/install new guardrail at locations that do not meet current standard. Also, Contractor shall clear and grind in accordance with EDM 29.

Any Other Roads

The SCDOT HDM (2003 with updates) Chapter 14 and the *Roadside Design Guide* (AASHTO) edition 2006 with Chapter 6 Update, 3rd Edition shall be used based on traffic volumes, design speed, and slopes.

Clear zone for any facilities using curbs on this project shall comply with SCDOT HDM (2003 with updates) Chapter 14.

2.7.1 Safety Clearing

Clear and grind all trees and shrubs down and ground to a depth of 6" (0.5 feet) below grade or remove including stumps. Remove all debris (trash, limbs, dead logs, etc.). Once clearing and grinding operations are complete, the area shall be properly graded and seeded in accordance with Section 810 of SCDOT Standard Specifications (2007) and any applicable Supplemental Specifications.

Where existing fill slopes are protected by guardrail, clear and grind in accordance with EDM 29.

Safety Clearing shall apply to the following areas:

- The area between the NB SC-277 ramp and I-77
- The area between the SB SC-277 ramp and I-77
- The area bordered by I-77 and the two forks of the WB I-20/Alpine Rd on ramp
- The area between NB I-77 and the on ramp from US-1
- The area between SB I-77 and the on ramp from US-21 NB

~~Clear and grind all trees and shrubs 6" below grade or remove within the 46' clear zone with the following exceptions:~~

- ~~• Where backslopes are steeper than 3:1, clear and grind a distance of 10' beyond the ditch line.~~
- ~~• Where backslopes are equal to or flatter than 3:1, clear and grind to the 46' zone.~~
- ~~• Where existing fill slopes are protected by guardrail, clear and grind in accordance with EDM 29.~~

- In areas where new right of way or wetland impacts would be a result of achieving the clear zone requirement, substandard areas may be corrected or protected. If the shoulder can be graded to acceptable slopes without impacting wetlands, right of way, or immovable obstructions, then existing guardrail shall be removed and the shoulder graded to meet design standards.

All trees within the 46' zone shall be cut down and ground to a depth of 6" (0.5 feet) below grade or removed (including stumps). Remove all debris (trash, limbs, dead logs, etc.) within the 46' zone. Once clearing and grinding operations are complete, this area shall be properly graded and seeded in accordance with Section 810 of SCDOT Standard Specifications (2007) and any applicable Supplemental Specifications.

Clear zone for all other areas shall be developed in compliance with SCDOT Highway Design Manual Chapter 14 and the AASHTO Roadside Design Guide, with 2006 Chapter 6 update, 3rd Edition.

2.8 Sight Distance

Sight distance shall be developed in compliance with SCDOT Highway Design Manual Chapter 10.

The upper range value established in the current edition of AASHTO's "A Policy on Geometric Design of Highways and Streets," 2001, for the appropriate design speed shall be used.

2.9 Ramps

Ramps shall be developed in compliance with SCDOT Highway Design Manual Chapter 16.

Ramps shall be analyzed and corrected if there are deficiencies in acceleration and deceleration lane lengths.

Widen and reconstruct, where applicable, portion of the outside shoulder to provide a continuous auxiliary lane from Percival Road to I-20 along I-77 NB.

From Percival Road to I-20 along I-77 NB, widen and reconstruct as necessary to provide a continuous auxiliary lane between the two ramps.

Provide a two lane bifurcated exit from I-77 NB to I-20 as indicated in the "I-77 Signing Plan" provided in Attachment B.

Eliminate the existing condition (middle lane shared merge) on I-77 NB at SC 277. Provide a two lane parallel entrance ramp for SC 277 plus three thru lanes on I-77 NB. Properly Drop the outside acceleration lane from SC 277 before the SC 555 entrance ramp. Continue four lanes northbound to Killian Road. The fourth lane may be dropped at Killian Road.

Reconstruct and widen, where applicable, portion of the existing ramp to provide a continuous two lanes entrance ramp from Killian Road to I-77 SB. Once two lanes are developed parallel to I-77 SB, the outside lane shall be dropped. Four SB lanes shall continue to SC 277, at which time the lanes shall be bifurcated in accordance with the signing plan provided.

2.10 Roadside Barriers

Roadside barriers shall be developed in compliance with SCDOT Highway Design Manual Chapter 14. The following items shall be included in the work:

Guardrail: The Contractor shall be responsible for determining the existing guardrail or end treatments that do not meet current design standards. All existing mainline guardrail, ramp guardrail, and end treatments within the project limits that is damaged or does not meet current design standards shall be replaced, reset or reused as a part of the project. All new, reset or reused guardrail and end treatments must be listed on the Qualified Products Policies & Listings. New guardrail shall be added where necessary in order to meet current design standards. Pavement under guardrail adjacent to paved shoulders shall be provided utilizing HMA Surface Type B at a rate of 200 300 psy. Paving under guardrail shall be provided in accordance with the guardrail posts in mow strips guidance found in the 2011 AASHTO Roadside Design Guide, Exhibit 5, Special Provisions, Section 403.

Additional length guardrail posts with compressed guardrail shoulder break shall be used only where right of way or environmental impacts dictate that standard guardrail shoulder break cannot be built.

Thrie-beam guardrail with critical offset posts shall not be use at the bridge piers.

Cable Median Barrier: The Contractor shall provide a single run of cable median barrier in all medians less than or equal to 72 feet and greater than or equal to 36 feet. Cable median barrier shall be in installed in accordance with SCDOT standard drawings and specifications. All existing mainline cable median barrier within the project limits that is damaged or does not meet current design standards shall be replaced as a part of the project. This work shall include all necessary median grading, drainage adjustments, and any other work necessary to meet current design standards.

The CONTRACTOR shall not use Double Run Cable Median Barrier. Concrete median barrier shall be used in the areas where median slopes cannot accommodate for a single run of cable barrier. Pave entire area between travelway and concrete median barrier.

Concrete Median Barrier: The Contractor shall provide concrete median barrier in all medians less than or equal to 36 feet in the widened section only. When concrete median barrier is constructed, the inside shoulder shall be paved to barrier. All new concrete median barriers shall be painted in accordance to

SCDOT Standard Specifications. All new concrete median barriers **on I-77** shall be single slope shaped.

NBL & SBL Overpasses over I-20 & I-20 Ramp: Remove and dispose of existing concrete median barrier and glare shield barrier extension on I-20 as necessary to construct the new substructures for the widened bridges. After substructure construction has been completed, replace the removed barrier and extension with new concrete median barrier **(match existing)** and glare shield barrier extension constructed in accordance with SCDOT Standard Drawings 805-806-00 and 805-895-00.

2.11 Right-Of-Way and Control Of Access

If right-of-way is required, it shall be the Contractor's responsibility to secure right-of-way in accordance with Uniform Relocation Assistance and Real Property Acquisition Policies Act of 1970 (Public Law 91-646), as amended and revise environmental document, if needed.

Maintain fully controlled access along interstate, all interchanges, and ramp intersections. SCDOT and FHWA guidelines for Control of Access at interstate interchanges shall be followed.

3.0 DELIVERABLES

All submittals to SCDOT shall be subjected to a thorough QC review by the Contractor prior to submittal. All RFC Plans submittals shall be signed and sealed by the Engineer of Record who shall be licensed and registered as a Professional Engineer in the State of South Carolina.

3.1 Preliminary Plans

The Contractor shall submit to the SCDOT:

- Four (4) half-size sets of preliminary plans shall include, at a minimum: title sheet, roadway typical section, roadway plan and profile, cross sections, clearing limits on plan view and cross sections, drainage features, proposed right-of-way, and preliminary geotechnical reports.
- Contractor shall provide one electronic copy of the plans and reports.
- Contractor shall also provide any design calculations requested in writing by SCDOT.
- If the Contractor does not anticipate the need for Right-of-Way Plans, the conceptual work zone traffic control plans shall be submitted with the Preliminary Plans.

3.2 **Right-of-Way Plans**

The Contractor shall submit to the SCDOT:

- Four (4) half-size sets of right-of-way plans are not a required submittal. However, if right-of-way is required and the Contractor wishes to pursue right-of-way acquisition prior to Final Plan submittal, Contractor has the option to submit right-of-way plans.
- Right-of-Way plans shall include, at a minimum: right-of-way data, roadway typical section, roadway plan and profile, cross sections, drainage features, conceptual work zone traffic control plans, existing right-of-way, and proposed new right-of-way requirements.
- If the Contractor elects to submit right-of-way plans, one electronic copy is also required.

3.3 **Final Plans**

The Contractor shall submit to the SCDOT:

- Four (4) half-size sets of final plans shall include, at a minimum: title sheet, roadway typical section, roadway plan and profile, cross sections, drainage design, sediment and erosion control design, existing right-of-way, proposed right-of-way, proposed barrier locations, and final geotechnical and hydraulic reports. The following traffic elements shall also be included: work zone traffic control plans, signing plans, and pavement markings plans.
- Contractor shall provide one electronic copy of the plans and calculations.
- Contractor shall also provide any design calculations requested in writing by SCDOT.

3.4 **Release for Construction (RFC) Plans**

For roadway plans, Contractor shall provide two full size sets, four half size sets, and one electronic copy of RFC Plans to SCDOT. RFC Plans shall be inserted into plan folders as detailed in the SCDOT plan and preparation guide.

EXHIBIT 4b

STRUCTURES DESIGN CRITERIA

1.0 GENERAL

Exhibit 4b contains requirements for:

- the widening and rehabilitation of the NBL & SBL Overpasses over I-20 & I-20 Ramp, NBL & SBL Overpasses over I-77 Ramp E (File 40.835.6 in existing plans), NBL & SBL Overpasses over Windsor Lake Boulevard (S-1196), NBL & SBL Bridges over Windsor Lake, and NBL & SBL Overpasses over Little Jackson Creek/Edgewater Drive (S-1722),
- the rehabilitation of the bridge deck of the SBL Overpass over US 21,
- any necessary retaining walls, and
- any necessary box culverts or box culvert extensions, and
- concrete median barriers.

2.0 CRITERIA

2.1 Bridges

2.1.1 Design Specifications

Design of the widened bridges shall be based on the AASHTO Standard Specifications for Highway Bridges, Seventeenth Edition – 2002. The design live loading shall be HS 20-44 Loading or an Alternate Military Loading of two axles four feet apart with each axle weighing 24,000 pounds, whichever produces the greater stress. If Load Factor Design (LFD) is used, then live load shall be increased by 25 percent. The Contractor shall demonstrate that any modifications to existing bridges do not lower the existing load rating of the structure. The Contractor shall not make any modifications to the existing bridges that would cause the load ratings of the bridges to be lowered.

No detailed seismic structural analysis of the bridges is required. However, the widened substructures shall be designed/detailed to meet the requirements of the SCDOT Seismic Design Specifications for Highway Bridges for SDC A Bridges.

Design of pier (bent) protection shall be based on the AASHTO LRFD Bridge Design Specifications.

For the Dual Overpasses over I-77 Ramp E, design of the traffic railing and deck overhang of the widened bridge decks shall also conform to the requirements of the AASHTO LRFD Bridge Design Specifications.

2.1.2 Dimensions

The widened bridges shall accommodate an additional 12-ft. inside lane, 12-ft. inside shoulder, and new inside barrier with slab extension. See Typical Section below.

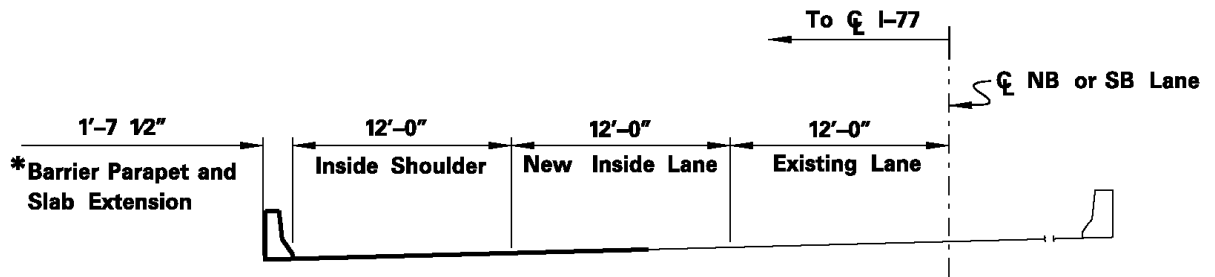

TYPICAL SECTION – WIDENED BRIDGE

* For the Dual Overpasses over I-77 Ramp E, a 42-inch high concrete barrier shall be used on the widened bridge decks.

2.1.3 Superstructure Types

For this project, Section 12.3.3 of the SCDOT Bridge Design Manual shall not be used. Allowable superstructure types are outlined in Sections 12.3.2.2, 12.3.2.3, and 12.3.2.4 of the SCDOT Bridge Design Manual. An Alternative Technical Concept will not be considered if it includes a superstructure type for the bridge widenings other than those listed in Sections 12.3.2.2, 12.3.2.3, and 12.3.2.4 of the SCDOT Bridge Design Manual.

Structural steel girders or beams shall be “I” shaped. Structural steel for the beams, girders, and diaphragms shall conform to the requirements of AASHTO M 270 Gr. 36 or AASHTO M 270 Gr. 50 and shall be painted in accordance with Section 710 of the Standard Specifications. The color of the final coat of paint shall match the color of the existing beams and girders.

At each support, beams and girders shall be connected to the substructure with anchor bolts.

All widenings and construction stages for girder bridges shall consist of a minimum of two lines of girders.

2.1.4 Concrete Strengths

In piles, concrete strengths up to 8,000 psi maximum may be used. All cast-in-place concrete bridge components shall be constructed with Class 4000 concrete. All precast concrete bridge components shall be constructed with concrete having a minimum compressive strength of 5000 psi.

2.1.5 Final Finish of Exposed Concrete Surfaces

Final surface finish will not be required on this project.

2.1.6 Lightweight Concrete

Lightweight Concrete will not be permitted for this project.

2.1.7 Post-Tensioning

Post-tensioning will not be permitted for this project.

2.1.8 Bridge Decks

The wearing surface of the decks shall be concrete. A transverse Grooved Surface Finish shall be applied to all widened decks in accordance with Subsection 702.4.16 of the Standard Specifications for Highway Construction. The new portion of the bridge decks shall have a minimum thickness of 8 inches and the thickness of the widened flat slab spans shall match the thickness of the existing spans.

The connection of the reinforcing of the new deck with the existing deck shall be made by lap-splice or mechanical splice. The existing decks shall be removed to a point beyond the existing gutter line and deck drains. A 1-inch vertical saw cut shall be made in the existing slab where the slab is to be removed. Removal shall conform to Section 202 of the Standard Specifications for Highway Construction.

2.1.9 Stay-in-Place Bridge Deck Forms

Permanent stay-in-place ~~steel~~ bridge deck forms for concrete deck slabs may be used between new beams and girders at the Contractor's option. Permanent stay-in-place bridge deck forms and supports shall be fabricated from steel conforming to ASTM A 446/A 653, Grades 40 or 50, and having a coating class of G165 in accordance with ASTM A 525. Fillers shall not be used in the flutes of the stay-in-place forms. Form flutes shall be filled with concrete as the deck slab is placed. Permanent stay-in-place steel bridge deck forms are not allowed in bays in which longitudinal deck construction joints are located and are not allowed in bays between new and existing beams or girders.

2.1.10 Barriers

With the exception of the Dual Overpasses over I-77 Ramp E, the SCDOT Standard Barrier Parapet shall be used on the widened bridge decks. For the Dual Overpasses over I-77 Ramp E, a 42-inch high concrete barrier shall be used on the widened bridge decks. The 42-inch barrier shall be ~~structurally and geometrically capable of surviving the crash test designed~~

for Test Level 5, as specified in Section 13 of the AASHTO LRFD Bridge Design Specifications. It is acceptable to use a bridge rail design that is similar to a crash tested design based on an analytic comparison using the methodology outlined in Section 13 of the AASHTO LRFD Bridge Specifications. The width of the barrier at the base shall be a minimum of 18 inches, the traffic face shall be vertical and the height shall transition at a 10:1 maximum rate to 32 inches at ends where thrie beam guardrail is attached. At ends where thrie beam is required, the barrier shall be detailed using the standard thrie beam attachment details (the End Wall segment that is 4 feet in length and 32-inch high) shown on Bridge Drawings and Details Drawing 702-30b.

2.1.11 Transition Curbs

For the interstate mainline bridges, construct a transition curb at the ends of barrier parapets that will be retained and that meet both of the following conditions:

- Thrie beam guardrail is attached to the end of the barrier; and
- There is not an existing curb or drainage feature located at the end of the barrier.

For transition curb details and requirements, see SCDOT Standard Drawing No. 403-205-02.

2.1.12 Barrier End Treatment

At the north end of the SBL Overpass over US 21, new reinforced concrete barrier transitions shall be constructed at the ends of the existing barrier parapets and metal railing. The new barriers shall have a height of 40 inches at the end adjacent to the existing rail and the height shall transition at a 10:1 maximum rate to 32 inches at the ends where thrie beam guardrail is attached. At these ends, the barrier shall be detailed using the standard thrie beam attachment details (the End Wall segment that is 4 feet in length and 32-inch high) shown on Bridge Drawings and Details Drawing 702-30b. The barrier transition shall be supported by a moment slab or the transitional slab may be widened as necessary to support the barrier transition. Any existing drainage features that are impacted by the new barrier transitions shall be reconstructed.

2.1.13 Concrete Barrier for Pier Protection

Concrete barrier for pier Pier protection shall be provided for Bent 3 of the Underpass under EBL of SC 277. new and existing bents located within a distance of 30 feet to the edge of a roadway. Concrete barrier for pier Pier protection shall consist of either a structurally independent, crashworthy ground mounted 54-inch high barrier, located within 10 feet from the column or a 42-inch high barrier located at more than 10 feet from the

column. Such barrier shall be structurally and geometrically capable of surviving the crash test for Test Level 5, as specified in Section 13 of the AASHTO LRFD Bridge Design Specifications. Maintain a minimum of 6 inches from the edge of the column to the nearest edge of the pier protection. The pier protection shall be designed and detailed in a manner that will not obstruct drainage and will allow for easy maintenance of the area around/between barriers.

Bents located a distance of 30 feet or greater from the edge of roadway, but are within the clear zone, shall be protected in accordance with the requirements of Exhibit 4a.

2.1.14 Approach and Transitional Slabs

With the exception of the Overpasses over Little Jackson Creek/Edgewater Drive and the north end of the NBL Bridge over Windsor Lake, the approach slabs of the widened bridges shall also be widened to accommodate an additional 12-ft. inside lane, 12-ft. inside shoulder, and new barrier parapet. The approach roadway ends of the new approach slabs shall align with the approach roadway ends of the existing approach slabs. The widened approach slabs shall be constructed at grade (without an asphalt overlay). The new slabs shall be connected to the existing slabs by removing the existing approach slab concrete to a width sufficient to splice to existing steel or by connecting with adhesive anchors.

The Overpasses over Little Jackson Creek/Edgewater Drive and the SBL Overpass over US 21 do not contain traditional approach slabs. Instead, they have two transitional reinforced concrete slabs at each end of each bridge. The transitional slabs connect the bridges to the continuously reinforced concrete approach pavement. These existing transitional slabs shall be completely removed and replaced with new slabs. The width of the new slabs shall match the total width of the ~~travel lanes~~ existing and new portland cement concrete approach pavement. For reinforcing steel size and slab thickness requirements, see the existing plans (File 40.973 & 40.973.3). Class 4000 concrete and ASTM A 706 Grade 60 reinforcing steel shall be used. The joints shall be sealed with a cold applied elastic filler. Fill under the slabs shall be thoroughly compacted in accordance with Section 208 of the Standard Specifications. Where required by staged construction, transverse reinforcing steel shall be lap spliced (Class B minimum) or mechanically connected.

At the north end of the NBL Bridge over Windsor Lake, the existing approach slab shall be removed in accordance with Section 202 of the Standard Specifications for Highway Construction and replaced with a new approach slab. The new approach slab shall be the same length as the existing slab (30 feet plus/minus), shall be 12 inches thick, and shall be

constructed at grade. Fill under the new slab shall be thoroughly compacted in accordance with Section 208 of the Standard Specifications. Where required by staged construction, transverse reinforcing steel shall be lap spliced (Class B minimum) or mechanically connected.

A transverse Grooved Surface Finish shall be applied to all widened approach slabs and to all new **approach and transitional** slabs in accordance with Subsection 702.4.16 of the Standard Specifications for Highway Construction.

2.1.15 Deck Drainage

The bridge deck drainage shall be designed to ensure that minimum requirements of the SCDOT Bridge Design Manual are met and that erosion of the end fill slopes is prevented due to excessive run off at the bridge ends. For decks where the existing drainage will remain in place, the Contractor shall make modifications if capacity needs to be increased to handle the additional runoff from the widened decks. Because there are low points on the Overpasses over Little Jackson Creek/Edgewater Drive, a 50-year Design Flood Frequency shall be used in the deck drainage design for those bridges.

Bridge deck drainage systems of existing overpass bridges shall be modified if necessary to prevent free-falling discharge from spilling onto the new inside shoulder and new inside lane or onto concrete barrier walls. Modifications of existing bridge drainage systems shall comply with the requirements of Chapter 18 of the SCDOT Bridge Design Manual.

2.1.16 Pile Sizes and Types

Minimum pile sizes and acceptable pile types are listed below. No other pile types will be permitted.

PILE TYPE	MINIMUM SIZE
Steel H-Piles	HP12x53
Steel Pipe Piles	12" Diam. (min. wall thickness equal to 1/2")
Solid Prestressed Concrete Piles	18" Square
Prestressed Concrete Pile Points	W8x58

2.1.17 Steel Pipe Pile Connection Details

The pile connection detail described in Item 2 of Section 19.2.6.3 of the SCDOT Bridge Design Manual shall not be used for this project. Steel pipe piles shall be terminated at the bottom of the end bent cap or footing

and the piles must be connected to the bent cap using a reinforced concrete infill, with the reinforcing extending into the cap or footing.

2.1.18 Crosshole Sonic Logging (CSL) Testing

Crosshole sonic logging (CSL) access tubes shall be installed in all drilled shafts in accordance with the SCDOT Standard Specifications for Highway Construction, 2007 Edition. CSL testing will be conducted by SCDOT on all of the shafts.

2.1.19 Substructures

Bridge spread footings will not be permitted. Deep foundations are required to extend below any compacted fill. Existing multi-column interior bents shall be widened using cast-in-place reinforced concrete bent caps and columns supported on cast-in-place reinforced concrete drilled shafts or pile footings. Existing interior pile bents shall be widened using cast-in-place reinforced concrete bent caps and a single row of prestressed concrete piles. The piles may be battered transversely (along the bent centerline), but longitudinal batter (perpendicular to the bent centerline) will not be permitted. **New portions of end bents and interior pile bents shall be connected to the existing end bents and interior pile bents.**

2.1.20 Integral Interior Bent Caps

Integral interior bent caps will not be permitted for this project.

2.1.21 Bridge Rehabilitation Requirements

I-77 Overpasses over I-20 & I-20 Ramp

Reseal existing deflection joints (4 Ea.), replace existing expansion joints (4 Ea.), and replace existing expansion bearings (55 Ea.).

I-77 Overpasses over I-77 Ramp E

Reseal existing deflection joints (4 Ea.), replace existing expansion joints (4 Ea.), and replace existing expansion bearings (30 Ea.).

I-77 Overpasses over Windsor Lake Blvd.

Reseal existing deflection joints (4 Ea.), replace existing expansion joints (4 Ea.), replace existing expansion bearings (45 Ea.), and perform partial depth concrete bridge deck repairs (approx. 10 SY as directed by the RCE).

I-77 Bridges over Windsor Lake

Reseal existing deflection joints (4 Ea.), replace existing expansion joints (12 Ea.), replace existing expansion bearings on NB bridge (7 Ea.), perform partial depth concrete bridge deck repairs (approx. 20

SY as directed by the RCE), perform substructure patching (approx. 135 SF of epoxy mortar patch as directed by the RCE), and replace the approach slab at the north end of the NBL bridge.

I-77 Overpasses over Little Jackson Creek/Edgewater Drive

Reseal existing deflection joints (4 Ea.), replace existing expansion joints (10 Ea.), replace existing expansion bearings (14 Ea.), perform partial depth concrete bridge deck repairs (approx. 50 SY as directed by the RCE), and replace transitional slabs at each end of bridge (See Section 2.1.14).

I-77 SBL Overpass over US 21

Reseal existing deflection joints (2 Ea.), reseal existing expansion joints (3 Ea.), perform partial depth concrete bridge deck repairs (approx. 90 SY as directed by the RCE), perform full depth concrete bridge deck repairs (approx. 15 CY as directed by the RCE), replace transitional slabs at each end of bridge (See Section 2.1.14), and construct barrier end treatments (See Section 2.1.12).

For requirements of resealing joints, replacing joints, replacing bearings, performing deck repairs, and performing substructure patching, see Exhibit 5.

2.1.22 Bridge End Fills

With the exception of the Bridges over Windsor Lake and the southern end of the Overpasses over Little Jackson Creek/Edgewater Drive, provide concrete slope protection on bridge end fills below all widened portions of the bridges. Additionally, concrete slope protection shall be provided on the northern end fills of the existing Overpasses over Little Jackson Creek/Edgewater Drive. Any existing slope protection that is damaged or removed during construction shall be replaced. Concrete slope protection shall have a minimum thickness of 4 inches. Use details and notes as applicable that are located on Drawing No. 804-1 of the Bridge Drawings and Details and the requirements of Section 804 of the Standard Specifications for Highway Construction.

At the Bridges over Windsor Lake and the southern end of the Overpasses over Little Jackson Creek/Edgewater Drive, repair, shape, and firmly compact the end fill slopes beneath the existing bridges.

2.1.23 Barriers Supported by Moment Slabs

When required, barriers supported by moment slabs shall be provided and designed in accordance with the AASHTO LRFD Bridge Design Specifications. The moment slabs shall be detailed independently of any

MSE walls as shown on Drawing No. 713-01d of the Bridge Drawings and Details.

2.1.24 Bridge Plans

As required by the SCDOT Bridge Design Manual, the bridge plans shall include Reinforcing Steel Schedules and Quantities Tables for each bridge component (end bents, interior bents, spans, etc.). When these components are required to be constructed in stages, the Reinforcing Steel Schedules and Quantities Tables shall be broken down by stage.

2.2 Retaining Walls

2.2.1 Mechanically Stabilized Earth (MSE) Walls

See Supplemental Technical Specification SC-M-713 and SCDOT Bridge Drawings and Details, Drawings No. 713-01 and 713-02.

MSE wall facing shall be precast concrete panels with a fractured fin finish at bridge abutments. MSE wall block facing may be implemented along roadway sections, provided the wall face is not visible to interstate traffic.

The minimum clear distance between the fill face of the MSE wall panels and the piles or drilled shafts shall be 3 feet. For two staged walls, the minimum clear distance between the fill face of stage 1 and the piles or drilled shafts shall be 3 feet.

Wall heights and lengths shall be designed to provide adequate cover for roadway and bridge drainage inlets and pipes in the roadway approaches and adequate slope transitions to maintain stable shoulders and slopes and design clearances and templates in accordance with the design criteria.

MSE wall heights greater than the maximum specified wall heights in the SCDOT Geotechnical Design Manual shall be approved by the SCDOT.

A concrete paved drainage ditch shall be provided along the top of the wall as shown on the SCDOT Bridge Drawings and Details.

2.2.2 Reinforced Concrete Walls

Selection criteria for reinforced concrete walls shall be based on FHWA Publication FHWA NHI-07-071 entitled Earth Retaining Structures, 2008.

These walls shall be designed in accordance with the 2012 AASHTO LRFD Bridge Design Specifications, Sixth Edition (with 2013 Interim Revisions) and FHWA Publication FHWA NHI-07-071 entitled Earth Retaining Structures, 2008.

Spread footings are permitted for concrete retaining walls that are not directly supporting bridges.

2.2.3 Other Wall Types

Other acceptable wall types include Precast Counterfort walls (which may be used in conjunction with traditional MSE walls in partial rock cuts), Tangent Pile/Secant Pile walls, Anchored walls, Sheet Pile walls **having reinforced concrete coping**, Soldier Pile and Lagging walls, and Soil-Nailed walls.

Prior to commencing any designs of other wall types as specified herein, the Contractor shall submit to SCDOT the wall type selected, design methodology, design criteria, and material and construction specifications for review. Design criteria shall include wall geometry and location, resistance factors, soil properties, and material properties of the wall. If the walls support bridge embankments, conceptual bridge plans must also be submitted in accordance with Section 3.2 of the SCDOT Bridge Design Manual. Shop plans and any calculations for other wall types shall be submitted in accordance with Section 725 of the SCDOT 2007 Standard Specifications for Highway Construction.

2.2.4 Plans Preparation

Retaining wall plans are typically included within the set of roadway plans and the sheets are numbered using an “S” prefix. **The wall construction plan sheets shall present the following information:**

2.2.4.1 Design Information

The design parameters shall be indicated in the plans.

2.2.4.2 Plan View

A plan view shall be provided that includes the following information and details:

- proposed wall location,
- centerline of roadway,
- stationing,
- stations and offsets of beginning and end of wall,
- length of wall,
- guard rail (if required),
- drainage basins/flumes,
- construction staging (if required),
- north arrow,

- existing structures, features, and utilities in vicinity of the wall if they impact construction,
- temporary shoring (if required), and
- boring locations.

2.2.4.3 Elevation View

An elevation view shall be provided that shows the top of the wall elevations and the existing ground line. The elevation view shall also show the final ground line along each face of the wall.

2.2.4.4 Details

Details of each wall component and requirements of the architectural or finish treatment shall be included.

2.2.4.5 Cross Sections

Section views of the wall shall be provided.

2.2.4.6 Reinforcing Steel Schedule and Quantities

If the construction of the wall includes reinforcing steel, include a reinforcing steel schedule that lists the reinforcing steel required for the wall. The schedule shall include the mark, number of bars required, and dimensions for each reinforcing bar. Also, a table of estimated quantities shall be provided for each wall. For projects requiring stage construction, the reinforcing steel schedule and quantities shall be broken down by stage.

2.2.4.7 Special Details

Details for construction of walls around buried foundations, drainage facilities, pipe penetrations, and utilities shall be included in the plans.

2.2.4.8 Boring Logs

Copies of the boring logs shall be included.

2.3 **Box Culverts**

2.3.1 Design Specifications

All new culverts shall be designed in accordance with the requirements of the AASHTO LRFD Bridge Design Specifications. The design live loading shall be HL-93.

The extensions of existing culverts may be designed in accordance with the Seventeenth Edition of the AASHTO Standard Specifications for Highway Bridges if the existing culvert was designed using the AASHTO Standard Specifications for Highway Bridges. The design live loading for these culvert extensions shall be HS 20-44 Loading or an Alternate Military Loading of two axles four feet apart with each axle weighing 24,000 pounds, whichever produces the greater stress.

Culverts that convey water shall be hydraulically designed in accordance with the requirements of the SCDOT Requirements for Hydraulic Design Studies.

Subsurface investigations for culverts shall comply with the requirements of the SCDOT Geotechnical Design Manual.

Seismic effects for new culverts shall be considered as required by the SCDOT Seismic Design Specifications for Highway Bridges. ~~Seismic effects for culverts need not be considered, except when they are subject to seismically induced ground deformations.~~

2.3.2 Materials

Class 4000 concrete (minimum) shall be used for cast-in-place elements of culverts and Class 5000 concrete (minimum) shall be used for precast elements of culverts.

Reinforcing bars shall conform to the requirements of ASTM A 706, Grade 60. Welded Wire Fabric shall meet the requirements of AASHTO M 55 or AASHTO M 221.

2.3.3 Design and Detailing Requirements

2.3.3.1 General

Culverts will not be allowed as a substitute for bridges specified in this project. Culverts shall have four sides and shall be constructed of reinforced concrete.

The length of the culvert should be established so that, at the end of the culvert, the theoretical fill slope is 1 foot below the top of the top slab. The culvert headwalls should be located outside of the adjusted clear zone (see SCDOT Standard Drawing No. 805-010-00) where practical or the exposed portions of the structure shall be appropriately shielded.

Weep holes and French drains shall be detailed in accordance with Section 702 of the SCDOT Standard Specifications for Highway

Construction. The weep holes shall be located 12 inches above the normal water line.

For culverts that convey water, rip rap and geotextile fabric shall be detailed at both ends of the culvert in accordance with SCDOT Standard Drawing No. 804-205-00.

The maximum allowable settlement for a culvert is 8 inches from the beginning of construction until the end of the 75-year design life of the culvert. The maximum allowable differential settlement along the length of a culvert is limited to 1 inch per 50 feet of culvert length. If deep foundations are used to limit the settlement of a culvert, the longitudinal differential settlement between the culvert and the adjacent paved embankment should not exceed 1 inch in 20 years.

Additional reinforcing steel shall be detailed at openings in the top slab or side walls to meet or exceed the reinforcement shown on SCDOT Standard Drawing No. 722-105-02.

All box culverts, whether cast-in-place or precast, shall be detailed with cast-in-place wing walls, head walls, aprons, and cut-off walls on both the inlet and outlet ends. Precast wing walls, head walls, aprons, cut-off walls, and footings are not permitted.

In situations where guardrail is required and installation of the posts conflicts with the top slab of the culvert, a 12'-6" long span of nested guardrail shall be detailed to bypass the culvert if site and culvert geometry permit. For details of the nested guardrail, see SCDOT Standard Drawing No. 805-565-00. As shown on this drawing, a 10:1 or flatter slope must be detailed for the shoulder area and a minimum 5'-6" offset must be maintained between the face of the guardrail and the back of the head wall. When nested guardrail is required, the plans shall include a note specifying that the guardrail must be installed in accordance with SCDOT Standard Drawing No. 805-565-00.

If guardrail is required and site and culvert geometry do not permit the nested guardrail installation, a moment slab is required to anchor the guardrail. The moment slab shall be designed and detailed to eliminate transfer of moment to the culvert barrel. The moment slab may be attached to the culvert barrel for resistance to sliding forces; the connection must be designed and detailed to resist horizontal sliding forces only.

2.3.3.2 Wing Walls

Wing walls are typically flared out approximately 30 degrees in relation to the centerline of the culvert, but the angle may vary based on site conditions. The wing walls shall be detailed so that the top of the wing wall is at least 12 inches above the finished ground line. The wing wall height should be designed and detailed so that, at the junction of the wing wall and culvert barrel, the top of the wing wall is the same elevation as the top of the top slab of the culvert barrel. The wing wall may be terminated when the height is such that the soil can wrap around the exposed face of the wing wall, using a slope of 2H:1V or flatter, without encroaching on the projected barrel opening.

Wing walls may be supported by footings or aprons, but no support shall be assumed from the culvert barrel(s).

The thickness of wing walls shall be equal to or greater than the exterior wall thickness of the culvert. If the maximum wing wall height is greater than 5 feet and the wing wall has a layer of reinforcing in each face, a minimum of 5 inches of clearance shall be provided between the mats of reinforcing steel.

2.3.3.3 Aprons

For box culverts, aprons shall be detailed as continuously cast-in-place concrete placed from end to end of the wing walls. Aprons may cover the entire area between the wing walls and the ends of the culvert barrel(s) or may follow the edges of the wing wall/culvert barrel(s). The aprons may be designed to support the wing walls. The thickness of the aprons shall be equal to or greater than the thickness of the bottom slab unless the bottom slab thickness exceeds 12 inches. If the bottom slab thickness exceeds 12 inches, the apron thickness need not be greater than 12 inches unless required by design.

2.3.3.4 Cut-off Walls

Cut-off walls shall be detailed with a minimum thickness of 10 inches. Cut-off walls shall be detailed to extend a minimum of 2 feet below the bottom of the bottom slab or apron. Cut-off walls shall also extend to a depth 2 feet below the scour depth or into unweathered rock. If cut-off walls are used as structural elements, appropriate reinforcement must be designed and detailed in the plans.

2.3.3.5 Head Walls

Head walls shall be detailed with a minimum height of 12 inches above the finished ground line and a minimum thickness of 12

inches. Head walls shall extend the full width of the culvert barrel(s).

The head walls shall be anchored to the top slabs of culverts with reinforcing steel that has been designed and detailed to resist overturning and sliding. Each face of the head wall shall be detailed with a minimum of 0.2 square inches of reinforcing steel per foot in each direction.

2.3.3.6 Concrete Cover

For cast-in-place box culverts, concrete cover to reinforcing shall be provided in accordance with the AASHTO LRFD Bridge Design Specifications. For W/C ratios that are less than or equal to 0.4, the concrete cover modification factor shall be taken as 1.0.

Precast box culverts in counties other than Beaufort, Berkeley, Charleston, Colleton, Dorchester, Georgetown, Horry, and Jasper shall have a clear cover as shown in ASTM C 1433 or ASTM C 1577 as appropriate. Precast box culverts that convey intermittent flow in Beaufort, Berkeley, Charleston, Colleton, Dorchester, Georgetown, Horry, and Jasper counties shall have a clear cover as shown in ASTM C 1433 or ASTM C 1577 as appropriate. Precast box culverts that convey permanent flow in Beaufort, Berkeley, Charleston, Colleton, Dorchester, Georgetown, Horry, and Jasper counties shall have a minimum of 3 inches of clear cover for reinforcing.

2.3.3.7 Extensions

~~For any proposed culvert extensions, the designer must evaluate the existing culvert to ensure its current condition is structurally adequate to permit extension rather than replacement and to determine if any rehabilitation work is needed.~~

All box culvert extensions of existing cast-in-place culverts shall be constructed of cast-in-place concrete. Extensions of existing precast culverts may be constructed of either precast sections or cast-in-place concrete. If precast sections are used, the extensions shall be designed and detailed with a cast-in-place concrete transition between the end of the existing barrel and the first new section of precast barrel.

For extensions of existing culverts, adhesive anchors, #6 (#19) or greater in size, shall be detailed at a maximum spacing of 18 inches in the exposed ends of the existing barrel. The interior barrel shape of the new culvert shall match that of the existing

culvert (i.e. chamfers, ledges, etc.) except as noted in Section 2.3.4.3.

2.3.4 Cast-in-Place Concrete Box Culverts

2.3.4.1 General

For culverts with skews greater than 25 degrees, the transverse reinforcing steel shall be designed and detailed perpendicular to the longitudinal reinforcing steel. For lesser skew angles, the transverse reinforcing steel may be designed and detailed parallel to the skew.

At the discontinuous edges of culvert barrel sections, edge beams shall be designed for the top and bottom slabs.

2.3.4.2 Slabs

Cast-in-place box culvert top and bottom slabs shall have a minimum thickness of 10 inches.

2.3.4.3 Walls

Cast-in-place box culvert walls shall be vertical and shall have a minimum thickness of 8 inches. If the vertical opening dimension of the culvert is greater than 5 feet, a minimum of 5 inches of clearance shall be provided between mats of reinforcing in the walls.

For extensions of existing multi-barrel culverts having interior wall thicknesses less than the new wall thicknesses, a minimum 6:1 transition shall be detailed at the junction of the new and existing interior walls.

2.3.4.4 Construction Joints

The maximum pouring length of cast-in-place culvert barrel sections shall be limited to 70 feet. Keyed transverse construction joints must be detailed in the barrel(s) as required to meet this limit. The longitudinal reinforcing steel shall be detailed continuous across the joints.

If the volume of cast-in-place concrete exceeds 225 CY in any pour, provide a pouring sequence on the plans. All concrete pours must be completed in less than 5 hours. If a pouring rate greater than 45 CY/hr is needed, the plans shall indicate the required pouring rate.

A keyed construction joint shall be detailed in the walls, 4 inches above the top of the bottom slab. When the height of the wall, measured from the top of the bottom slab, is 8 feet or greater, a keyed construction joint shall also be detailed between the walls and top slab.

For construction joints located between elevations of extreme low tide and extreme high tide, the plans shall include requirements for the joint to be sealed. Each exterior side of the joint shall be detailed with a ½ inch chamfer on the upper side of the joint. The plans must specify that the ½ inch chamfer be sealed with a bonding epoxy conforming to ASTM C 881, Type IV, Grade 3, and that the epoxy be applied in accordance with the manufacturer's written instructions.

2.3.5 Precast Concrete Box Culverts

2.3.5.1 General

Precast box culvert sections are not allowed if any of the following conditions exist:

- the design earth cover exceeds 20 feet,
- the design earth cover is less than 2 feet,
- the culvert is an extension of an existing cast-in-place culvert, or
- the culvert will be used for pedestrian traffic.

Monolithically cast box culvert sections shall be specified. Precast concrete split box culvert sections are not permitted.

2.3.5.2 Design Requirements

Precast box culvert sections for new culverts shall be designed in accordance with ASTM C 1577 except when clear cover for reinforcing is required to be 3 inches. Precast box culvert sections for culvert extensions of existing precast culverts shall be designed in accordance with either ASTM C 1577 or ASTM C 1433 except when clear cover for reinforcing is required to be 3 inches. For precast culverts having design fill heights greater than 5 feet, the design fill height shall be rounded to the next higher 5 foot increment when using the tabulated design information from ASTM C 1577 or ASTM C 1433.

2.3.5.3 Detailing Requirements

Precast box culverts shall be detailed in accordance with SCDOT Standard Drawing No. 722-305-00 and Section 722 of the SCDOT

Standard Specifications for Highway Construction. The plans shall require all precast box culverts to be placed on a prepared bed of aggregate (Coarse Aggregate No. 5, No. 56, or No. 57) having a minimum thickness of 6 inches. The aggregate bed must extend the entire width and length of the culvert plus 3 inches beyond the outer walls of the barrel(s).

The plans for precast box culverts shall include details for cast-in-place wing walls, head walls, aprons, cut-off walls, and footings. These cast-in-place elements shall comply with the requirements of Section 2.3.3 and shall be attached to the precast culvert barrel(s) using #6 (#19) adhesive anchors detailed at a maximum spacing of 18 inches in the exposed ends of the barrel(s). These elements shall be designed to be self-supporting. The adhesive anchors are intended to control differential settlement only.

Where multiple precast box culvert barrels are placed side by side, the plans shall require a 3½ inch minimum and 6 inch maximum space between adjacent barrel sections. The plans shall require this space to be filled with flowable fill or cast-in-place concrete. If the space is filled with flowable fill, the plans shall require that, at both the upstream and downstream ends, the last 6 inches of space between the barrels (measured along the longitudinal direction of the barrels) be filled with a cast-in-place concrete cap for the full height of the barrels.

2.3.6 Plans Preparation

Culvert plans are typically included within the set of roadway plans and the sheets are numbered using an “S” prefix. The culvert plan sheets shall present the following information:

2.3.6.1 Title Blocks.

The title blocks of the culvert sheets shall include the fill height used to design the culvert, the culvert opening size (span x rise), the station at centerline of culvert, and the slope of fills.

2.3.6.2 Location Sketch.

A location sketch shall be provided that includes the following information and details:

- proposed culvert outline,
- existing culvert outline as a light, dashed line,
- centerline of roadway,
- direction of stationing,

- station of intersection of roadway centerline and culvert centerline,
- dimensions of culvert barrels,
- length of each end of culvert measured from the roadway centerline,
- skew angle,
- construction staging (if required),
- temporary shoring locations (if required for construction),
- permissible types of temporary shoring (if restricted),
- stream name,
- direction of flow,
- limits of riprap or note that riprap shall be in accordance with SCDOT Standard Drawing No. 804-205-00 (if required),
- north arrow,
- existing structures, features, utilities in vicinity of culvert if they impact culvert construction,
- invert elevations at each end of new culvert or both ends of each side being extended,
- boring locations, and
- hydraulic data.

2.3.6.3 Design Information.

The design specification and live load shall be indicated in the plans.

2.3.6.4 Plan View.

A plan view shall be provided that details the culvert, apron, cut-off wall, wing wall, and footing dimensions; the reinforcing bars, bar callouts, and bar spacing; and the location of any required transverse construction joints.

2.3.6.5 Cross Section.

Section views of the barrel(s), wing walls, head walls, aprons, cut-off walls, and footings shall be provided detailing the dimensions; the reinforcing bars, bar callouts, and bar spacing; the weep holes and french drains; and the location of construction joints.

2.3.6.6 Reinforcing Steel Schedule and Quantities.

For each culvert, include a reinforcing steel schedule that lists the reinforcing steel required for the culvert. The schedule shall include the mark, number of bars required, and dimensions for each reinforcing bar. Immediately below the reinforcing steel schedule, include a list of estimated quantities for the culvert. All

quantities required for construction of the culvert (e.g., reinforcing steel, concrete, piling, excavation, riprap, geotextile, etc.) shall be included. For projects requiring stage construction, the reinforcing steel schedule and quantities shall be broken down by stage.

2.3.6.7 Boring Logs.

Copies of the boring logs shall be included in the plans.

2.4 Concrete Median Barriers

Slope the traffic faces of concrete median barrier at a constant 10.78 degrees (1H:5.25V) away from traffic. Provide an 8-inch minimum top barrier width and a minimum height, measured from top of pavement to top of barrier, of 54 inches. Apply the following requirements when designing concrete median barriers:

Condition A – Concrete Median Barrier with grade separations of less than 6 inches: Use details from the SCDOT Standard Drawings.

Condition B – Concrete Median Barrier with grade separations of 6 inches to 20 inches: Reinforce the barrier wall in accordance with Chapter 7 of Midwest States' Regional Pooled Fund Research Program: Development of a TL-5 Vertical Faced Concrete Median Barrier Incorporating Head Ejection Criteria (<http://nlcs1.nlc.state.ne.us/epubs/R6000/B016.0124-2007.pdf>). Calculate and detail the minimum expansion joint spacing required for stability analysis to resist the overturning of the Test Level 4 impact force at the increased moment arm generated by the grade separation.

Condition C – Concrete Median Barrier with grade separations between 20 inches and 36 inches: In addition to the design requirements of Condition B, design the barrier in accordance with AASHTO LRFD Bridge Design Specifications for a Test Level 4 impact, omitting Extreme Event I requirements.

Condition D – Concrete Median Barrier with grade separations 36 inches and greater: In addition to the design requirements of Condition B, design a cantilever wall barrier in accordance with AASHTO LRFD Bridge Design Specifications for a Test Level 4 impact and in accordance with SCDOT seismic design requirements.

For Conditions B, C, and D, use a transverse impact force of 54 kips for the strength design of the barrier as required by AASHTO. However, when evaluating the stability of the barrier, use a transverse force of 10 kips instead of the 54-kip load.

3.0 DELIVERABLES

All submittals to SCDOT shall be subjected to a thorough QC review by the Contractor prior to submittal.

3.1 Preliminary Structural Plans

The Contractor shall submit two half size sets and an electronic copy (in PDF format) of Preliminary Structural Plans for SCDOT’s review. Preliminary Structural Plans shall include, at a minimum, all items described in Chapter 3 of the SCDOT Bridge Design Manual. Partial submittal of the required contents of the preliminary set of plans will not be allowed. The Preliminary Geotechnical Report shall be submitted with the preliminary plans.

3.2 Final Structural Plans

The Contractor shall submit two half size sets and an electronic copy (in PDF format) of Final Structural Plans for SCDOT’s review. Final Structural Plans shall include, at a minimum, all items described in Chapter 3 of the SCDOT Bridge Design Manual. Partial submittal of the required contents of the final set of plans will not be allowed. The Final Geotechnical Report shall be submitted with the final plans.

3.3 Design Calculations

The Contractor shall provide an electronic copy (in PDF format) of all structural design calculations to SCDOT.

3.4 Release for Construction (RFC) Plans

The Contractor shall provide one full size set of RFC Plans to SCDOT. RFC plan submittals to SCDOT shall be signed and sealed by the State of South Carolina licensed Professional Engineer of Record. RFC Plans shall be inserted into plan covers as detailed in the SCDOT Bridge Design Manual.

3.5 Shop Plans

Shop plans, as defined by the Standard Specifications for Highway Construction, shall be submitted to the Contractor’s designer for review and approval. All approved shop plans shall be routed to SCDOT for review and distribution. Shop plan submittals shall meet the criteria of Subsection 725.1.1 of the Standard Specifications for Highway Construction. After reviewing the plans, SCDOT will either distribute the plans or provide comments. Comments shall be reviewed by the Contractor’s designer prior to the plans being resubmitted to the SCDOT for further review. Shop plans shall be stamped “approved” by the Contractor’s designer prior to submittal to SCDOT and shall be stamped and distributed by the SCDOT prior to commencing fabrication and/or construction/erection. All design calculations and shop plans shall bear the legible seal, date, and signature of the responsible engineer registered as a Professional Engineer in the State of South Carolina.

3.6 Working Drawings

Working drawings and design calculations, as defined by the Standard Specifications for Highway Construction, shall be submitted to the Contractor’s designer for review and approval. All approved working drawings and design calculations shall be routed to the SCDOT for review and distribution. Working drawings and design calculation submittals shall meet the criteria of Subsection 725.1.2 of the Standard Specifications for Highway Construction. SCDOT will review the drawings and calculations and either provide acceptance of the drawings as prepared or provide comments. Comments shall be reviewed by the Contractor’s designer prior to resubmittal to SCDOT for further review. Working drawings and design calculations shall be stamped “approved” by the Contractor’s designer prior to submittal to SCDOT and shall be stamped and distributed by the SCDOT prior to commencing construction/erection. All design calculations and working drawings shall bear the legible seal, date, and signature of the responsible engineer registered as a Professional Engineer in the State of South Carolina.

The Contractor is reminded that the SCDOT reviews the working drawings and design calculations only to verify that the specifications have been addressed.

EXHIBIT 4c

PAVEMENT DESIGN CRITERIA

1.0 GENERAL

The pavement shown in the Typical Section included in the SCDOT Conceptual Plans provided in Attachment B is for information only. The design for pavement shall conform to the criteria listed in Section 2.0.

Milled-in rumble strips shall be used on all mainline shoulders, both inside and outside, in accordance with SCDOT Standard Drawings and specifications for the entire project.

Transition areas not requiring pavement reconstruction or rehabilitation but requiring revised pavement markings shall be milled 2-inches and resurfaced utilizing 200 lbs/sy hot mix asphalt HMA Surface Type B and 110 lbs/sy Open Graded Friction Course (OGFC). These areas include, but are not limited to, existing I-20 pavement sections.

Include 2000 SY of 10" 9" full depth concrete patching and 1000 SY of full depth asphalt patching in accordance with the Special Provision in Exhibit 5.

2.0 CRITERIA

2.1 Mainline Pavement New Lane

Construct a composite pavement for the mainline travel lane. Construct a plain jointed portland cement concrete (PCC) pavement overlaid with a HMA pavement having the following characteristics:

2.1.1 HMA Overlay

Place two (2) 200 psy lifts of Surface Type B with PG76-22 and one (1) 110 psy lift of OGFC. Extend OGFC four (4) feet beyond pavement edge line.

2.1.2 PCC Pavement

Thickness:	10"
Transverse Joint Spacing:	15'
Transverse Load Transfer:	1.5" dowels, 18" long, spaced 12" c-c, mainline only
Surface Texture:	Mainline – Heavy Broom
Joint Sealant:	NA (saw cut joints only)
Nominal Compressive Strength:	5500 psi
Base:	6" GABC overlaid with 200 lbs Surface C

PCC pavement elevation shall match existing concrete pavement. When placing PCC pavement adjacent to existing asphalt section (approximate

EXHIBIT 4c – PAVEMENT DESIGN CRITERIA

mile marker 15 to 17.5) saw cut existing pavement structure at the joint to create a clean vertical surface throughout the depth of PCC pavement and base. The new mainline PCC shall meet the requirements of SC-M-502 Section 5.1.6 Profilograph Measurement prior to placement of overlay. Final Rideability will be measured after overlay and be in accordance with SC-M-403.

For all new PCC pavements construct an expansion joint of a design acceptable to the Department when abutting bridges or other structures. At bridge ends and other rigid obstructions, provide three (3) expansion joints one (1) inch in width located at the obstruction and 75 feet and 150 feet away from the obstruction. Obtain approval of expansion joint assembly and detail from the RCE prior to construction.

In Section 5.6.1 of SC-M-501(0308), the compressive strength of 4000 psi is removed and replaced with 5500 psi.

Section 6.3.3.1 of SC-M-501(0308) is removed and replaced with the following:

6.3.3.1 Furnish a suitable concrete compression testing machine meeting the requirements of ASTM C39. Have the machine professionally calibrated after installation in the field laboratory and prior to commencement of work. Maintain proper calibration of the equipment for the duration of the project.

Section 7.4.2 and 7.4.3 of SC-M-501(0308) shall be adjusted for compressive strength of 5500 psi such that the same percentages are applied.

No ATC's will be considered for the above defined pavement types of PCC overlaid with HMA.

2.2 New and Existing Shoulders (Station 1302+50 to 1801+15)

The shoulders shall be surfaced with HMA pavement having a minimum thickness equal to the mainline overlay. Existing shoulders have a Structural Number equal to 3.30. Attachment B provides a limited number of asphalt thickness cores and Falling Weight Deflectometer testing of the existing shoulders. This information should be used at the design build teams risk. Plans from previous projects indicate the existing shoulder sections vary. For new shoulders the base materials can be selected from the following list by the design build team. New and existing shoulders shall not have a structural number less than 5.36 calculated in accordance with SCDOT Pavement Design Guide. Allowable base materials include: Cement Stabilized Aggregate Base, Graded Aggregate Base, Asphalt Aggregate Base, Cement Modified Subbase, PCC

pavement, Roller Compacted Concrete. Submit all pavement design calculations for review. Submittal schedule for pavement design on shoulders shall follow the ATC milestones.

If PCC pavement is selected, tie to new PCC mainline with #5 tie bar, 30" long, 30" c-c. Match adjacent concrete pavement thickness. Do not tie to continually reinforced concrete pavement section. ~~Nominal compressive strength of concrete shall not exceed mainline mixture design.~~

2.3 Existing PCC Pavement

Milling of the existing PCC pavement is not allowed other than for transverse tie-ins. Perform full-depth patching as required in the Exhibit 5 Special Provisions. Tack at a rate of 0.08 to 0.10 gal/yd². Correct the cross slope with Asphalt Surface Type E with PG76-22 for correction up to 1.5 inches and Asphalt Surface Type B (with PG76-22) for greater correction. Overlay with 200 psy Surface Type B (with PG-76-22), 200 psy Surface Type B (with PG-76-22) and 110 psy OGFC matching new mainline composite pavement.

To meet the existing pavement grade, perform two variable milling operations up to 2.5 inches in depth to smoothly tie in the ~~intermediate course for the first operation and the surface and OGFC courses in the second asphalt pavement.~~ This variable milling shall extend a minimum of 75 feet for each lift to ensure smooth transitions.

2.4 Existing HMA Pavement (Station 1170+00 to 1302+50)

Mill 2 inches. Overlay with 200 psy Surface Type B (with PG-76-22) and 110 psy OGFC.

2.5 Ramp Pavement

Existing concrete ramps are to be full depth patched and overlaid with HMA matching mainline without OGFC. Carry the OGFC along the ramp to the gore, then variably mill 0 to 1 inch over a minimum of 75 feet and terminate the OGFC in a neat, smooth transverse joint. The overlay shall extend from the mainline to the edge of travel way of the existing crossing route. To meet the existing pavement grade, perform two variable milling operations up to 2.5 inches in depth to smoothly tie in the asphalt pavement. This variable milling shall extend a minimum of 75 feet for each lift to ensure smooth transitions. The final 75 feet of transition will only have one lift of asphalt. In this final transition, the asphalt overlay shall be sawed and sealed at the existing concrete joint locations.

Existing asphalt ramps are to be milled 2 inches and replaced with 200 lbs Surface

Type B (with PG 76-22). One exception to this is Killian Road on and off ramps South Bound which will be milled 4 inches or to the underlying PCC pavement and replaced with two lifts of 200 lbs Surface Type B (PG 76-22). The overlay shall extend from the mainline to the edge of travel way of the existing crossing route. Concrete patching may be necessary to rehabilitate the underlying concrete pavement in this location prior to overlay.

Existing six-inch curbs/gutters may be filled a maximum of two (2) inches when overlaying with new asphalt, leaving a minimum of four (4) inches of the face of the vertical curb exposed.

The pavement design for the new outside auxiliary lane along I-77 northbound that connects Percival Road onramp and I-20 off ramp will match the new mainline pavement identified in Section 2.1.

2.6 **Temporary Pavement**

Design of temporary pavement, including using the existing shoulder to carry the mainline traffic, is at the discretion of the Contractor. However, temporary pavement must provide a satisfactory rideability to the public prior to opening to traffic and during construction. Satisfactory rideability is defined as any 0.1 mile segment having roughness not to exceed 170 inches per mile when tested in accordance with SC-T-125. In addition to rideability, rutting shall not exceed 1/4" when the wheel paths are measured with a 4' straightedge.

Should potholes appear in the temporary pavement the Contractor shall take action within one calendar day to temporarily fill the pothole for safety. Once per week all temporarily filled pot holes shall be full depth patched varying in depth as necessary but shall be no less than 4 inches.

If temporary pavement is to be incorporated in the final pavement structure, it must minimally meet the structural requirements given in Section 2.2 of this Exhibit. Additionally, the pavement must be free of cracks and distortion prior to overlay. If the pavement has visible wear or deterioration, then take remedial action to improve or repair the pavement to the Department's satisfaction prior to overlaying.

EXHIBIT 4d

TRAFFIC DESIGN CRITERIA

Part 1 – Signing and Pavement Marking

1.0 GENERAL

1.1 Permanent Pavement Markings

Pavement marking work on this project consists of preparing detailed pavement marking plans and applying appropriate markings for the entire length of the project including both the widened and rehabilitated sections. All mainline and ramp edge lines and lane lines shall be to interstate standards as detailed in the Standard Drawings. Lane lines and edge lines shall be 6 inches in width. Exit and entrance gore markings shall be 12 inches in width. The final roadway surface material will determine which type of permanent marking material is to be applied. The CONTRACTOR shall use either polyurea or preformed tape (T-1) markings on concrete surfaces for the applications noted below. Thermoplastic markings shall be used on all asphalt surfaces. The CONTRACTOR shall install surface mounted raised pavement markers in accordance with the Standard Drawings.

1.2 Permanent Signing

Signing work on this project consists of preparing a detailed, comprehensive signing plan for the I-77 mainline and any **modified** interchange ramps **impacted by staging or final design**; and fabricating, furnishing, and erecting new ground mounted and overhead mounted signs, breakaway posts, overhead sign structures and delineators. Also included is the removal and relocation of the signs, delineators, overhead structures and supports to be replaced. The location of the signing work is on I-77 from Percival Road (Milepost 15 – Exit 15) to Killian Road (Milepost 22 – Exit 22) in Richland County. **Signing work is not included on the rehabilitation portion of the project from Milepost 22 to Milepost 27 unless impacted by staging or final design.** Impacts to signing include relocating, removing, or causing to be non-compliant.

2.0 CRITERIA

2.1 Permanent Pavement Markings

2.1.1 Thermoplastic Pavement Markings (Asphalt Surfaces)

All thermoplastic markings installed on the interstate mainline or any crossing routes shall meet the requirement of Section 627 of the Standard Specifications.

2.1.2 Polyurea Pavement Markings (Concrete Surfaces)

2.1.2.1 All polyurea markings installed on the interstate mainline, crossing routes or any bridge decks on this project shall be

a liquid, multi-component system that includes highly reflective elements.

2.1.2.2 The polyurea pavement marking lines shall have a minimum dry thickness of 20 mils when placed on concrete and asphalt pavements. The pavement marking material and highly reflective elements shall be applied in a simultaneous operation.

2.1.2.3 The CONTRACTOR shall apply the polyurea resin, mixed at the proper ratio according to the manufacturer's recommendations, to the pavement surfaces within the proper application temperatures as determined by the material manufacturer. Highly reflective elements shall be injected into the molten (liquid) polyurea pavement markings in accordance with the manufacturer's recommendations using a dispenser approved by the manufacturers of both the polyurea materials and the highly reflective elements.

2.1.2.4 Upon curing, the markings shall be uniformly reflectorized and have the ability to resist deformation caused by traffic throughout the entire length of the line.

2.1.2.5 If requested by the Engineer, the manufacturer of the selected polyurea material shall provide a technical representative, or a manufacturer's certified representative, to assure proper application technique by the contractor during the initial installation of the product.

2.1.2.6 All materials will be accepted based on manufacturer's certifications.

2.1.3 Preformed Patterned Tape (T-1) Pavement Markings (Options for Concrete Bridge Decks)

2.1.3.1 The CONTRACTOR may choose to apply preformed patterned tape markings to concrete bridge decks on this project. If this option is selected the markings shall be preformed patterned tape with a raised diamond pattern covered with ceramic elements having a refractive index of 1.9 or greater. All preformed tape markings installed on the bridge decks on this project shall be installed with a truck mounted application system or other motorized applicator approved by the manufacturer.

2.1.3.2 The CONTRACTOR shall provide to the Department the manufacturer's normal warranty which shall guarantee the tape materials for a period of 72 months from the date of installation from failure to retain the minimum reflectance values provided by the manufacturer and from failure due to loss of material adhesion or complete wear through. If failure occurs, the manufacturer will provide the replacement materials to restore the markings to their original effectiveness.

2.2 **Permanent Signing**

2.2.1 Maintenance of Mainline and Ramp Directional and Information (LOGO) Signing Mounted on I-Beam Breakaway Posts

2.2.1.1 The existing mainline and ramp directional and information signs mounted on I-beam breakaway posts may have to be relocated due to the construction. Where relocation is necessary, the mainline signs should be mounted temporarily on 4"x6" wood posts using the method detailed on Standard Drawing 625-120-00. Ramp information signs (logo) should be mounted temporarily on 4"x4" wood posts. No separate payment will be made for these relocations. All signs are to be maintained throughout construction.

2.2.1.2 In addition, the CONTRACTOR will be responsible for replacing signs damaged during construction which are to be retained (i.e. logo signs) and erected as part of the permanent signing. A Department representative should conduct an inspection/evaluation prior to and at the conclusion of construction to determine in any damage occurred during execution of the contract.

2.2.2 Bridge Clearance and Crossing Route Information Signing

2.2.2.1 The CONTRACTOR will be required to erect bridge vertical clearance and crossing route number flat sheet signs on the new bridge in both directions of travel. The signs shall be fabricated in accordance with the SCDOT sign numbers shown in the table below. The CONTRACTOR shall determine the actual minimum vertical clearance in each direction after all interstate mainline or crossing route surfacing is completed.

SCDOT Sign Number	Sign Description	Crossing Route Type
W12-2P-78	Vertical Clearance	All
OHB M1-1-48	Crossing Route Information	Interstate – 2 or 3 digit
OHB M1-4-48	Crossing Route Information	US Route – 2 digit
OHB M1-4-60	Crossing Route Information	US Route – 3 digit
OHB M1-5-48	Crossing Route Information	SC Route – 2 digit
OHB M1-5-60	Crossing Route Information	SC Route – 3 digit
OHB M1-6-78	Crossing Route Information	Secondary Route – 2 digit
OHB M1-6-84	Crossing Route Information	Secondary Route – 3 digit

2.2.2.2 Detailed layouts for the signs in table are available from SCDOT – Director of Traffic Engineering, (803) 737-1462. Written requests for detailed layouts shall be addressed to the POC.

2.2.2.3 The vertical clearance sign shall be centered over the centerline of the interstate or crossing route travel way. The crossing route number sign shall be placed to the left of the vertical clearance sign with a minimum spacing of 8 feet between the right of the route number sign and the left of the clearance sign.

- 2.2.2.4 The flat sheet panels may be mounted on the outside beam on each side of the bridge using 3-M Very High Bond Tape in accordance with the tape manufacturer's recommendations, or other method, such as direct bolting, approved by the Engineer.

2.3 Special Instructions to the Contractor

- 2.3.1 A conceptual signing plan is included in Attachment B of the RFP which shows the proposed sign locations and sign layouts for all overhead signs as well as all signs mounted on I-beam breakaway posts. Notes are provided on the plan for each sign location that details the sign size, sign identification numbers and a brief description of work to be accomplished. The conceptual plan does not show the location of flat sheet signs mounted on u-section posts (mile markers, warning signs, regulatory signs, etc.) along the I-77 mainline. These signs should be included in the comprehensive signing plan and replaced as part of this contract.
- 2.3.2 The CONTRACTOR shall contact the Director of Traffic Engineering within 30 days of the issuance of the Notice to Proceed to review the conceptual signing plan and the overall signing requirements of the contract. A complete as built set of signing plans should be submitted to the Director of Traffic Engineering at the conclusion of the project. The Director of Traffic Engineering will provide an example set of interstate signing plans to the Contractor at this meeting to use as a guide in preparation of the as built signing plans.
- 2.3.3 The CONTRACTOR is advised that SignCAD files for the all of the signs shown on the conceptual signing plan are available from the Director of Traffic Engineering. Written requests for the SignCAD files shall be addressed to the POC. The signs are designed using SignCAD software and Clearview Fonts.
- 2.3.4 Walkways should be included in the design of all new overhead structures as noted in the Standard Specifications. Sign lighting systems will not be required on the new overhead structures.
- 2.3.5 Guard rail should be included for all overhead uprights located within the clear zone on either side of the travel way. For guardrail installations that protect sign uprights, typically the face of the guardrail is located approximately 1 foot behind the edge of shoulder. The center of the upright should be located approximately 9 feet behind the face of guardrail.

- 2.3.6 The CONTRACTOR will be responsible for obtaining soil borings to be used for foundation designs for all new overhead sign structures.
- 2.3.7 The CONTRACTOR is advised that Logo signs may have to be relocated and I-beam supports replaced if exit ramps are significantly lengthened. Likewise, if entrance ramps are significantly lengthened, Speed Limit and Post Interchange Mileage signs that are noted as “Replace Sign – Refurbish Posts” will have to be relocated and I-beam supports replaced. Correct location for Speed Limit signs is 1500 feet beyond the end of the entrance taper. Correct location for Post Interchange Mileage Signs is 2500 beyond the end of the entrance taper.
- 2.3.8 The CONTRACTOR is advised that all signs have a unique barcode sticker attached to the back of each sign and each sign assembly has a unique barcode sticker attached to one post of the assembly. The CONTRACTOR will be required to record the barcode number for each sign and the associated assembly that is removed, replaced or relocated. These numbers and the date that the sign and assembly were removed, replaced or relocated shall be recorded on a form and the form shall be and turned into the Resident Construction Engineer.

3.0 DELIVERABLES

3.1 Permanent Pavement Marking Plans

The Contractor shall submit Permanent Pavement Marking Plans with the Final Plans for SCDOT’s review. Permanent Pavement Marking Plans shall include, at a minimum, all items described in this section of the RFP and all other applicable design references listed in Exhibit 4.

3.2 Permanent Signing Plans

The Contractor shall submit Permanent Signing Plans with the Final Plans for SCDOT’s review. Permanent Signing Plans shall include, at a minimum, all items described in this section of the RFP and all other applicable design references listed in Exhibit 4.

3.3 As-Built Signing Plans

A complete as-built set of signing plans, including SignCAD copies of all layouts, shall be submitted to the SCDOT as directed by the Director of Traffic Engineering at the conclusion of the project.

EXHIBIT 4d

TRAFFIC DESIGN CRITERIA

Part 2 – Work Zone Traffic Control

1.0 GENERAL

The Contractor shall execute the item of Traffic Control as required by the Standard Specifications, the Standard Drawings For Road Construction, the Special Provisions, all Supplemental Specifications, the SCDOT Procedures and Guidelines for Work Zone Traffic Control Design, the MUTCD, the Plans, and the Engineer. This is an amendment to the Standard Specifications to require the following:

2.0 CRITERIA

2.1 GENERAL REGULATIONS

These special provisions shall have priority to the plans and comply with the requirements of the MUTCD and the standard specifications. Revisions to the traffic control plan through modifications of the special provisions and the plans shall require approval by the Department. Final acceptance of any revisions to the traffic control plan shall be pending upon review by the member of the Design-Build team representing the Director of Traffic Engineering through the Design-Review Process.

In accordance with the document, *Rule on Work Zone Safety and Mobility: Implementation, Maintenance, and Safety Guidelines*, this project has been classified as “SIGNIFICANT” and all components of the Transportation Management Plan prepared by the CONTRACTOR are required and shall be implemented.

Install and utilize changeable message signs in all lane closures installed on high volume high-speed multilane roadways. Use of changeable message signs in lane closures installed on low volume low speed multilane roadways is optional unless otherwise directed by the plans and the Engineer. Install and use a changeable message sign within a lane closure set-up as directed by the *Standard Drawings For Road Construction*. When a lane closure is not present for any time to exceed 24 hours, remove the changeable message sign from the roadway. Place the sign in a predetermined area on the project site, as approved by the Engineer, where the sign is not visible to passing motorists. Utilize preprogrammed messages in accordance with the *Standard Drawings For Road Construction* when using the changeable message sign as part of the traffic control set-up for lane closures. Only those messages pertinent to the requirements of the traffic control situation and the traffic conditions are permitted for display on a changeable message sign at all times. At no time will the messages displayed on a changeable message sign duplicate the legends on the permanent construction signs.

During operation of changeable message signs, place the changeable message sign on the shoulder of the roadway no closer than 6 feet between the sign and the near edge of the adjacent travel lane. When the sign location is within 30’ of the

near edge of a travel lane open to traffic, supplement the sign location with no less than 5 portable plastic drums placed between the sign and the adjacent travel lane for delineation of the sign location. Install and maintain the drums no closer than 3 feet from the near edge of the adjacent travel lane. This requirement for delineation of the sign location shall apply during all times the sign location is within 30' of the near edge of a travel lane open to traffic, including times of operation and non-operation. Oversized cones are prohibited as a substitute for the portable plastic drums during this application.

All signs mounted on portable sign supports shall have a minimum mounting height of 5' from the bottom of the sign to the ground. All signs mounted on ground mounted u-channel posts or square steel tube posts shall have a minimum mounting height of 7' from the bottom of the sign to the grade elevation of the near edge of the adjacent travel lane or sidewalk when a sidewalk is present.

Temporary "Exit" signs (M1025-00) shall be located within each temporary gore during lane closures on multilane roadways. Mount these signs a minimum of 7' from the pavement surface to the bottom of the sign in accordance with the requirements of the MUTCD.

When mounting signs on ground mounted u-section or square steel tube posts, utilize either a sign support / ground support post combination with an approved breakaway assembly or a single direct driven post for each individual sign support of a sign assembly installation. Do not combine a sign support / ground support post combination and a direct driven post on the same sign assembly installation that contains two or more sign supports. Regarding sign support / ground support post combination installations, ensure that post lengths, stub heights and breakaway assemblies comply with the manufacturer's requirements and specifications. Use approved breakaway assemblies found on the *Approved Products List For Traffic Control Devices in Work Zones*.

When covering signs with opaque materials, the Department prohibits attaching a covering material to the face of the sign with tape or a similar product or any method that will leave a residue on the retroreflective sheeting. Residue from tape or similar products, as well as many methods utilized to remove such residue, damages the effective reflectivity of the sign. Therefore, contact of tape or a similar product with the retroreflective sheeting will require replacement of the sign. Cost for replacement of a sign damaged by improper covering methods will be considered incidental to providing and maintaining the sign; no additional payment will be made.

Overlays are prohibited on all rigid construction signs. The legends and borders on all rigid construction signs shall be either reversed screened or direct applied.

Signs not illustrated on the typical traffic control standard drawings designated for permanent construction signs shall be considered temporary and shall be included in the lump sum price bid item for “Traffic Control” unless otherwise specified.

Install “Grooved Pavement” signs (W8-15-48) supplemented with the “Motorcycle” plaque (W8-15P-30) in advance of milled or surface planed pavement surfaces. On primary routes, install these signs no further than 500 feet in advance of the beginning of the pavement condition. On interstate routes, install these signs no less than 500 feet in advance of the beginning of the pavement condition. Install two sign assemblies at each sign location, one on each side of the roadway, on multilane roadways when the pavement condition is present. Install these signs immediately upon creation of this pavement condition and maintain these signs until this pavement condition is eliminated.

Install “Steel Plate Ahead” signs (W8-24-48) in advance of an area of roadway where temporary steel plates are present. Install these signs no further than 300 feet in advance of locations where steel plates are present. On multilane roadways, comply with the same guidelines as applied to all other advance warning signs and install two sign assemblies at each sign location, one on each side of the roadway, when roadway conditions warrant. Install these signs immediately upon installation of a temporary steel plate and maintain the signs until the temporary steel plates are removed.

Install and maintain any necessary detour signing as specified by the typical traffic control standard drawings designated for detour signing, Part VI of the MUTCD, these Special Provisions, and the Engineer. The lump sum price bid item for “Traffic Control” includes payment for installation and maintenance of the detour signing.

The Contractor shall maintain the travel patterns as directed by the traffic control plans and shall execute construction schedules expeditiously. The Contractor shall provide the Resident Engineer with no less than a two-week prior notification of changes in traffic patterns.

During nighttime flagging operations, flaggers shall wear a safety vest and safety pants that comply with the requirements of ANSI / ISEA 107 standard performance for Class 3 risk exposure, latest revision, and a fluorescent hard hat. The safety vest and the safety pants shall be retroreflectorized and the color of the background material of the safety vest and safety pants shall be fluorescent orange-red or fluorescent yellow-green.

During nighttime flagging operations, the contractor shall illuminate each flagger station with any combination of portable lights, standard electric lights, existing street lights, etc., that will provide a minimum illumination level of 108 Lx or 10 fc.

During nighttime flagging operations, supplement the array of advance warning signs with a changeable message sign for each approach. These changeable message signs are not required during daytime flagging operations. Install the changeable message signs 500' in advance of the advance warning sign arrays. Messages should be "Flagger Ahead" and "Prepare To Stop".

During surface planing and milling operations, grade elevation differences greater than 1 inch in areas with pavements composed of hot mixed asphalt (HMA) base courses, intermediate courses or surface courses and Portland cement concrete are PROHIBITED unless otherwise directed by the Department. However, during surface planing and milling operations for removal of Open-Graded Friction courses ONLY, a grade elevation difference of 1½ inches between adjacent travel lanes opened to traffic may exist unless otherwise directed by the Department. During the paving operations, the length of roadway with an acceptable grade elevation difference less than or equal to 2" shall be restricted to 4 miles.

During the milling and surface planing operations, the length of roadway with an acceptable grade elevation difference less than or equal to 1" shall be restricted to 4 miles.

During construction on the ramps, the contractor shall conduct flagging operations. The flagging operations shall either stop traffic or direct the traffic around the work area. Installation and operation of these flagging operations shall be according to these special provisions and the MUTCD.

Supplement and delineate the shoulder edges of travel lanes through work zones with traffic control devices to provide motorists with a clear and positive travel path. Utilize portable plastic drums unless otherwise directed by the Department. Vertical panels may be used where specified by the plans and directed by the RCE. The installation of traffic control devices are required in all areas where those areas immediately adjacent to a travel lane open to traffic have been altered in any manner by work activities, including but not limited to activities such as grading, milling, etc. Install the traffic control devices immediately upon initiating any alterations to the areas immediately adjacent to or within 15 feet of the near edge line of the adjacent travel lane. When sufficient space is available, place the traffic control devices no closer than 3 feet from the near edge of the traffic control device to the near edge line on the adjacent travel lane. When sufficient space is unavailable, place the traffic control device at the maximum distance from the near edge of the adjacent travel lane available.

2.2 LANE CLOSURE RESTRICTIONS

The lane closure restrictions stated below are project specific, for all other restrictions, see supplemental specification, "Restrictions", dated January 3, 2013.

EXHIBIT 4d – TRAFFIC DESIGN CRITERIA – PART 2

On primary and secondary routes, the Department prohibits lane closures during any time of the day that traffic volumes exceed 800 vehicles per hour per direction. The Department reserves the right to suspend a lane closure if any resulting traffic backups are deemed excessive by the Engineer. Maintain all lane closure restrictions as directed by the plans, these special provisions, and the Engineer.

On Interstate 77, the Department prohibits lane closures on northbound I-77 as described in the following three tables. Monday through Friday from 6:00 am to 9:00 pm, Saturday from 7:00 am to 9:00 pm, and Sunday from 9:00 am to 9:00 pm. The Department prohibits lane closures on southbound I-77 Monday through Wednesday from 6:00 am to 8:00 pm, Thursday from 6:00 am to 9:00 pm, Friday from 6:00 am to 9:00 pm, Saturday from 7:00 am to 8:00 pm, and Sunday from 8:00 am to 8:00 pm.

HOURLY LANE CLOSURE PROHIBITIONS (NORTHBOUND I-77)	HOURLY LANE CLOSURE PROHIBITIONS (SOUTHBOUND I-77)
MON-FRI: 6A-9P	MON-WED: 6A-8P
SAT: 7A-9P	THU-FRI: 6A-9P
SUN: 9A-9P	SAT: 7A-8P
	SUN: 8A-8P

I-77 LANE CLOSURE PROHIBITIONS (6-LANE SECTION FROM I-20 SOUTHERLY)			
NB I-77 (Single Closure)	SB I-77 (Single Closure)	NB I-77 (Dual Closure)	SB I-77 (Dual Closure)
MON-THU: 4P-6P	MON-THU: 7A-8A 4P-6P	MON-THU: 6A-8P	MON: 6A-7P
			TUE-THU: 6A-8P
FRI: 3P-6P	FRI: 7A-8A 1P-6P	FRI: 6A-9P	FRI: 6A-9P
SAT: -----	SAT: 10A-2P	SAT: 7A-8P	SAT: 7A-8P
SUN: -----	SUN: -----	SUN: 10A-8P	SUN: 9A-8P

I-77 LANE CLOSURE PROHIBITIONS (4-LANE SECTION FROM I-20 TO SC 277)			
NB I-77 (Single Closure)	SB I-77 (Single Closure)	NB I-77 (Dual Closure)	SB I-77 (Dual Closure)
MON-THU: 7A-8P	MON-WED: 6A-7P THU: 6A-8P	NA	NA
FRI: 7A-9P	FRI: 6A-8P		
SAT: 8A-8P	SAT: 8A-7P		
SUN: 10A-8P	SUN: 9A-8P		

I-77 LANE CLOSURE PROHIBITIONS (6-LANE SECTION FROM SC 277 NORTHERLY)			
NB I-77 (Single Closure)	SB I-77 (Single Closure)	NB I-77 (Dual Closure)	SB I-77 (Dual Closure)
MON-WED: 4P-6P THU: 3P-6P	MON-THU: 7A-9A	MON-WED: 7A-8P THU: 7A-9P	MON-TUE: 6A-7P WED-THU: 6A-8P
FRI: 2P-6P	FRI: 7A-9A 2P-6P	FRI: 7A-9P	FRI: 6A-9P
SAT: 1P-5P	SAT: 10A-2P	SAT: 8A-9P	SAT: 8A-9P
SUN: 2P-4P	SUN: -----	SUN: 9A-9P	SUN: 9A-9P

On Interstate 20, the Department prohibits lane closures on eastbound I-20 as described in the following table. Monday through Tuesday from 7:00 am to 7:00 pm, Wednesday through Friday from 7:00 am to 8:00 pm, Saturday from 8:00 am to 8:00 pm, and Sunday from 10:00 am to 8:00 pm. The Department prohibits lane closures on westbound I-20 Monday through Thursday from 7:00 am to 7:00 pm, Friday from 7:00 am to 8:00 pm, Saturday from 9:00 am to 7:00 pm, and Sunday from 10:00 am to 8:00 pm.

HOURLY LANE CLOSURE PROHIBITIONS (EASTBOUND I-20)	HOURLY LANE CLOSURE PROHIBITIONS (WESTBOUND I-20)
MON-TUE: 7A-7P	MON-THU: 7A-7P
WED-FRI: 7A-8P	FRI: 7A-8P
SAT: 8A-8P	SAT: 9A-7P
SUN: 10A-8P	SUN: 10A-8P

I-20 LANE CLOSURE PROHIBITIONS (6-LANE SECTION FROM MP 68-84)			
EB I-20 (Single Closure)	WB I-20 (Single Closure)	EB I-20 (Dual Closure)	WB I-20 (Dual Closure)
MON-TUE: 7A-7P	MON-THU: 7A-7P	MON-TUE: 6A-10P	MON-WED: 6A-10P
WED-THU: 7A-8P		WED-THU: 6A-11P	THU: 6A-11P
FRI: 7A-8P	FRI: 7A-8P	FRI: 6A-12A (Mid-Night)	FRI: 6A-12A (Mid-Night)
SAT: 8A-8P	SAT: 9A-7P	SAT: 7A-11P	SAT: 7A-11P
SUN: 10A-8P	SUN: 10A-8P	SUN: 8A-10P	SUN: 8A-10P

On SC 277, the Department prohibits lane closures on Monday through Friday from 7:00 am to 9:00 am and 4:00 pm to 6:00 pm.

All other routes with lane closure prohibitions for this project are listed on the SCDOT website under Doing Business with SCDOT in the Publications and Manuals section for Traffic Engineering.

These restrictions also apply to all road closures and pacing operations. The Department reserves the right to suspend a lane closure if any resulting traffic backups are deemed excessive by the Engineer. Maintain all lane closure restrictions as directed by the plans, these special provisions, and the Engineer.

Installation and maintenance of a lane closure is PROHIBITED when the Contractor is not actively engaged in work activities specific to the location of the lane closure unless otherwise specified and approved by the Engineer. The length of the lane closure shall not exceed the length of roadway anticipated to be subjected to the proposed work activities within the work shift time frame or the maximum lane closure length specified unless otherwise approved by the Engineer. Also, the maximum lane closure length specified does not warrant installation of the specified lane closure length when the length of the lane closure necessary for conducting the work activity is less. The length and duration of each lane closure, within the specified parameters, shall require approval by the Engineer prior to installation. The length and duration of each lane closure may be reduced by the Engineer if the work zone impacts generated by a lane closure are deemed excessive or unnecessary.

On multilane primary and secondary routes, a reduced regulatory speed limit of 35 MPH shall be in effect during lane closures. Erect temporary regulatory “Speed Limit” signs (R2-1-48-35) and “Speed Reduction 35 MPH” signs (W3-5-48-35) on temporary supports according to the typical traffic control standard drawings. Cover the existing regulatory speed limit signs when reduced speed limits are in place. Immediately remove or cover the “Speed Limit” signs (R2-1-

48-35) and the “Speed Reduction 35 MPH” signs (W3-5-48-35) upon the removal of the lane closures.

On interstate routes, a reduced regulatory speed limit of 45 MPH shall be in effect during lane closures. Erect temporary regulatory “Speed Limit” signs (R2-1-48-45) and “Speed Reduction 45 MPH” signs (W3-5-48-45) on temporary supports according to the typical traffic control standard drawings. Cover the existing regulatory speed limit signs when reduced speed limits are in place. Immediately remove or cover the “Speed Limit” signs (R2-1-48-45) and the “Speed Reduction 45 MPH” signs (W3-5-48-45) upon the removal of the lane closures.

On interstate routes, the presence of temporary signs, portable sign supports, traffic control devices, trailer mounted equipment, truck mounted equipment, vehicles and vehicles with trailers relative to the installation or removal of a closure and personnel are prohibited within 30 foot clear zone during the prohibitive hours for lane closures specified by these special provisions.

Truck mounted changeable message signs shall be required during all interstate lane closures. The Contractor shall provide, install, and maintain these signs in accordance with all requirements of the Standard Specifications for Highway Construction (latest edition) and the typical traffic control standard drawings designated for interstate lane closures.

The truck mounted changeable message signs are in addition to the requirements for trailer mounted changeable message signs. Truck mounted changeable message signs and trailer mounted changeable message signs are not interchangeable.

The Contractor shall discontinue and remove a lane closure when the work activities requiring the presence of the lane closure are completed or are discontinued or disrupted for any period of time to exceed 60 minutes unless the presence of unacceptable grade elevation differences greater than 1” in milled areas or greater than 2” in all other areas are present unless otherwise directed by the Engineer.

2.3 SHOULDER CLOSURE RESTRICTIONS:

On primary and secondary routes, the Department prohibits the Contractor from conducting work within 15’ of the near edge of the adjacent travel lane on an outside shoulder or a median area under a shoulder closure during any time of the day that traffic volumes exceed 800 vehicles per hour per direction. The hourly restrictions for lane closures shall also apply to work activities conducted under a shoulder closure within 15’ of the near edge of an adjacent travel lane or a median area. The Department reserves the right to suspend work conducted under a shoulder closure if any traffic backups develop and are deemed excessive by the

Engineer. Maintain all shoulder closure restrictions as directed by the plans, these special provisions, and the Engineer.

On primary and secondary roadways, the Department prohibits the Contractor from conducting work within 1' or less of the near edge of an adjacent travel lane under a shoulder closure. All work that may require the presence of personnel, tools, equipment, materials, vehicles, etc., within 1' of the near edge of an adjacent travel lane shall be conducted under a lane closure.

On Interstate 77, the Department prohibits the Contractor from conducting work within 15' of the near edge of the adjacent travel lane on the outside shoulders or the median areas during the times listed in section 2.2 Lane Closure Restrictions of northbound I-77 Monday through Friday from 6:00 am to 9:00 pm, on Saturdays from 7:00 am to 9:00 pm, and on Sundays from 9:00 am to 9:00 pm. The Department prohibits the Contractor from conducting work within 15' of the near edge of the adjacent travel lane on the outside shoulders or the median areas of southbound I-77 Monday through Wednesday from 6:00 am to 8:00 pm, on Thursdays from 6:00 am to 9:00 pm, on Fridays from 6:00 am to 9:00 pm, on Saturdays from 7:00 am to 8:00 pm, and on Sundays from 8:00 am to 8:00 pm. The hourly restrictions for lane closures shall also apply to work activities conducted under a shoulder closure within 15' of the near edge of an adjacent travel lane or a median area. The Department reserves the right to suspend work conducted under a shoulder closure if any traffic backups develop and are deemed excessive by the Engineer. Maintain all shoulder closure restrictions as directed by the plans, these special provisions, and the Engineer.

On interstate highways, the Department prohibits the Contractor from conducting work within the limits of a paved shoulder or within 10' of the near edge of an adjacent travel lane under a shoulder closure. All work that may require the presence of personnel, tools, equipment, materials, vehicles, etc., within the limits of a paved shoulder or within 10' of the near edge of an adjacent travel lane shall be conducted under a lane closure.

The Contractor shall install all shoulder closures as directed by the typical traffic control standard drawings designated for shoulder closures, and the Engineer. Substitution of the portable plastic drums with oversized cones during nighttime shoulder closures is PROHIBITED.

2.4 MOBILE OPERATIONS

A mobile operation moves continuously at all times at speeds of 3 mph or greater without any stops. The minimal traffic flow impacts generated by these operations involve brief traffic flow speed reductions and travel path diversions. Conduct work operations that cannot be performed at speeds of 3 mph or greater under standard stationary lane closures.

The distance intervals between the vehicles, as indicated in the *Standard Drawings For Road Construction*, may require adjustments to compensate for sight distance obstructions created by hills and curves and any other conditions that may obstruct the sight distance between the vehicles. However, adjustments to the distance intervals between the vehicles should be maintained within the range of variable distance intervals indicated in the standard drawings unless otherwise directed by the Engineer.

Maintain two-way radio communication between all vehicles in the vehicle train operating in a mobile operation.

Supplement the work vehicles and the shadow vehicles with amber colored flashing dome lights. The vehicles may also be supplemented with advance warning arrow panels and truck mounted attenuators as directed in the *Standard Drawings For Road Construction* and the Standard Specifications.

The Contractor shall install, operate and maintain all advance warning arrow panels, truck mounted attenuators and truck mounted changeable message signs as required by these special provisions, the manufacturer's specifications, the *Standard Drawings For Road Construction*, the Standard Specifications, the plans and the Engineer.

2.5 TYPICAL TRAFFIC CONTROL STANDARD DRAWINGS:

The typical traffic control standard drawings of the “Standard Drawings For Road Construction”, although compliant with the MUTCD, shall take precedence over the MUTCD. The typical traffic control standard drawings of the “Standard Drawings For Road Construction” shall apply to all projects let to contract.

Install the permanent construction signs as shown on the typical traffic control standard drawings designated for permanent construction signing.

2.6 ADDENDUMS

(Addendums to the “2007 Standard Specifications for Highway Construction”)

2.6.1 Construction (Sub-section 601.4) –

Sub-section 601.4.2 Construction Vehicles (paragraph 2) -

When working within the rights-of-way of access-controlled roadways such as Interstate highways, the Contractor's vehicles may only change direction of travel at interchanges. These vehicles are prohibited from crossing the roadway from right side to the median or vice versa. Use a flagger to control the Contractor's vehicles when these vehicles attempt to enter the roadway from a closed lane or the median area. Ensure the

flagger does not stop roadway traffic, cause roadway traffic to change lanes, or affect roadway traffic in any manner. The Contractor's vehicles may not disrupt the normal flow of roadway traffic or enter the travel lane of the roadway until a sufficient gap is present.

The Contractor shall have flaggers available to control all construction vehicles entering or crossing the travel lanes of secondary and primary routes. The RCE shall determine the necessity of these flaggers for control of these construction vehicles. The RCE shall consider sight distance, vertical and horizontal curves of the roadway, prevailing speeds of roadway traffic, frequency of construction vehicles entering or crossing the roadway and other site conditions that may impact the safety of the workers and motorists when determining the necessity of these flaggers. Ensure these flaggers do not stop roadway traffic, cause roadway traffic to change lanes or affect roadway traffic in any manner. The Contractor's vehicles may not disrupt the normal flow of roadway traffic or enter the travel lane of the roadway until a sufficient gap is present.

When working within the rights-of-way of access-controlled roadways with posted regulatory speed limits of 55 MPH or greater and average daily traffic volumes {ADT} of 10,000 vehicles per day or greater, i.e. Interstate highways, all construction and work vehicles possessing any one or more of the vehicular characteristics listed below are only permitted to enter and exit a right or left shoulder work area during the presence of active lane closures unless otherwise directed by the RCE. These vehicles are not permitted to enter or exit these work areas without the presence of active lane closures unless otherwise directed by the RCE. Shoulder closures are unacceptable and insufficient methods for control of traffic at ingress / egress areas for these vehicles. The restrictive vehicular characteristics include the following:

- Over six (6) tires
- Tandem rear axles
- A base curb weight greater than 8000 lbs.
- A gross vehicular weight greater than 12000 lbs. unless performing duties as a shadow vehicle while supporting a truck mounted attenuator
- A trailer in tow except under the following conditions:
 - Trailers transporting traffic control devices (including but not limited to standard and 42" oversized traffic cones, portable plastic drums, signs, portable sign supports, u-channel and square steel tube sign posts) relative to the installation of lane closures, shoulder closures or other traffic control operations approved by the RCE

- Trailer mounted traffic control devices (including but not limited to advance warning arrow panels, changeable message signs, temporary traffic signals, highway advisory radios, work zone intelligent transportation systems and trailer towed truck mounted attenuators)

2.6.2 **Construction** (Sub-section 601.4) –

Sub-section 601.4.2 Construction Vehicles -

Auxiliary Warning Lights for Vehicles and Equipment -

Supplement all construction and/or construction-related vehicles and equipment that operate in a stationary or mobile work zone within or adjacent to a roadway within the highway rights-of-way with AMBER or YELLOW colored high intensity rotating or strobe type flashing auxiliary warning light devices. Utilize, install, operate and maintain a single or multiple lighting devices as necessary to provide visibility to approaching motorists.

All auxiliary warning light models shall meet *Society of Automotive Engineers* (SAE) Class I standards and SAE Standard J575 relative to *Tests for Motor Vehicle Lighting Devices and Components* and these specifications.

The amber/yellow color of the dome/lens of an auxiliary warning light device shall meet SAE Standard J578 for amber/yellow color specifications.

Auxiliary warning lights with parabolic reflectors that rotate shall rotate around a halogen lamp at a rate to produce approximately 175 flashes per minute. The parabolic reflector shall produce a minimum 80,000 candle power and a minimum 54,000 candela through an SAE Standard J846 approved amber dome.

Equip strobe type flashing auxiliary warning light devices with photosensitive circuit controls to adjust the lighting intensity in response to changes in ambient light conditions such as from day to night. These lights shall have a double-flash capability rated at approximately 80 double flashes per minute and produce a minimum 24 joules of flash energy at the highest power level setting.

Acceptable auxiliary warning light models shall provide sufficient light output to be clearly recognizable at a minimum distance of 1750 feet.

Mount all auxiliary warning light devices intended to function as the auxiliary warning light system or as an element thereof on vehicles and equipment at locations no less than 3 feet above the ground and in conspicuous locations to provide visibility to approaching motorists.

Auxiliary warning light devices and/or models that mount in the locations of the standard vehicle lighting system are unacceptable as the specified auxiliary warning light system due to restrictive simultaneous visibility capabilities from multiple sight angles. However, auxiliary warning light devices that mount in the standard vehicle lighting system locations are acceptable as supplements to the specified lighting devices mounted in locations that do meet the minimum height requirements and provide simultaneous visibility capabilities from multiple sight angles.

Standard vehicle hazard warning lights are only permitted as supplements to the specified auxiliary warning light devices.

2.6.3 Category I Traffic Control Devices (Section 603) –

Sub-section 603.2.2 Oversized Traffic Cones (paragraph 6) -

Reflectorize each oversized traffic cone with 4 retroreflective bands: 2 orange and 2 white retroreflective bands. Alternate the orange and white retroreflective bands, with the top band always being orange. Make each retroreflective band not less than 6 inches wide. Utilize Type III – Microprismatic retroreflective sheeting for retroreflectorization on all projects let to contract after May 1, 2010 unless otherwise specified. Separate each retroreflective band with not more than a 2-inch non-reflectorized area. Do not splice the retroreflective sheeting to create the 6-inch retroreflective bands. Apply the retroreflective sheeting directly to the cone surface. Do not apply the retroreflective sheeting over a pre-existing layer of retroreflective sheeting.

Sub-section 603.2.3 Portable Plastic Drums (paragraph 3) -

Reflectorize each drum with Type III – Microprismatic retroreflective sheeting: 2 orange and 2 white retroreflective bands, 6 inches wide on all projects let to contract after May 1, 2010 unless otherwise specified. Alternate the orange and white retroreflective bands with the top band always being orange. Ensure that any non-reflectorized area between the orange and white retroreflective bands does not exceed 2 inches. Do not splice the retroreflective sheeting to create the 6-inch retroreflective bands. Apply the retroreflective sheeting directly to the drum surface. Do not apply the retroreflective sheeting over a pre-existing layer of retroreflective sheeting.

2.6.4 Category II Traffic Control Devices (Section 604) –**Sub-section 604.2.1 Type I and Type II Barricades (paragraph 3) -**

Reflectorize these barricades with Type VIII or IX Prismatic retroreflective sheeting on all projects let to contract after May 1, 2012 unless otherwise specified. Ensure that the retroreflective sheeting has alternate orange and white stripes sloping downward at a 45-degree angle in the direction of passing traffic. The stripes shall be 6 inches wide.

Sub-section 604.2.2 Type III Barricades (paragraph 3) -

Reflectorize these barricades with Type VIII or IX Prismatic retroreflective sheeting on all projects let to contract after May 1, 2012 unless otherwise specified. Ensure that the retroreflective sheeting has alternate orange and white stripes sloping downward at a 45-degree angle. Apply the sloping orange and white stripes in accordance with the requirements of the Plans, SCDOT Standard Drawings and the MUTCD. The stripes shall be 6 inches wide.

2.6.5 Temporary Concrete Barrier (Sub-section 605.2.3.2) –**Sub-section 605.2.3.2 Temporary Concrete Barrier (paragraph 6) -**

Previously used temporary concrete barrier walls are subject to inspection and approval by the RCE before use. Ensure that previously used temporary concrete barrier walls are in good condition. Defects to a temporary concrete barrier wall that may disqualify a section of wall for use include gouges, cracks, chipped, or spalled areas. A defect that exposes reinforcing steel warrants immediate disqualification. A disqualification grade type defect shall consist of measurements in excess of 1 inch, entirely or partially within the boundaries of the end connection areas and the drainage slot areas as illustrated in the “Standard Drawings for Road Construction”, and/or in excess of 4 inches for all areas beyond the end connection areas. To warrant disqualification, these measurements shall exceed the specified dimensions in all three directions, width, height, and depth. A defect that exceeds the specified dimensions in only one or two of the three directions does not warrant disqualification.

Temporary concrete barrier walls with defects less than 6 inches in all three directions, width, height, and depth that do not expose reinforcing steel may be repaired in accordance with the following requirements. Repair is prohibited on temporary concrete barrier walls with defects 6 inches or greater in all three directions, width, height, and depth.

For repair of temporary concrete barrier walls with defects less than 6 inches in all three directions, width, height, and depth that do not expose reinforcing steel, repair the defect with a premanufactured patching material specifically fabricated for patching structural concrete. The strength of the patch must meet or exceed the design strength of the class 3000 concrete of the temporary concrete barrier wall. Perform the repair procedures in accordance with all requirements and instructions from the manufacturer of the patch material. Use a bonding compound between the patch material and the concrete unless specifically stated by the manufacturer that a bonding compound is not required. If the manufacturer states that application of a bonding compound is optional, SCDOT requires application of a bonding compound compatible with the patch material. If cracking occurs within the patched area, remove the patch material completely and repeat the repair process. The contractor shall submit documentation stating all repairs have been conducted in accordance with these requirements prior to installing any temporary concrete barrier walls with repairs. Utilization of temporary concrete barrier walls with repairs shall require approval by the RCE prior to installation.

The Contractor shall submit certification documents for the patch material utilized for repairs to the Engineer prior to placing temporary concrete barrier walls that have been repaired on the project site.

2.6.6 Truck-Mounted Attenuator (Sub-section 605.4.2.2) –

Sub-section 605.2.2.2.3.3 Color (paragraph 1) -

Use industrial grade enamel paint for cover of the metal aspects of the unit. Provide and attach supplemental striping to the rear face of the unit with a minimum Type III high intensity retroreflective sheeting unless otherwise directed by the Department. Utilize an alternating 4 to 8 inch black and 4 to 8 inch yellow 45-degree striping pattern that forms an inverted “V” at the center of the unit that slopes down and to the sides of the unit in both directions from the center.

2.6.7 Truck-Mounted Attenuator (Sub-section 605.4.2.2) –

Sub-section 605.4.2.2 Truck-Mounted Attenuators (paragraph 6) -

A direct truck mounted truck mounted attenuator is mounted and attached to brackets or similar devices connected to the frame of a truck with a minimum gross vehicular weight (GVW) of 15,000 pounds (actual weight) unless otherwise directed. A trailer towed truck mounted attenuator is towed from behind and attached via a standard pintle hook / hitch to the

frame of a truck with a minimum gross vehicular weight (GVW) of 10,000 pounds (actual weight) unless otherwise directed.

Each truck utilized with a truck mounted attenuator shall comply with the manufacturer's requirements to ensure proper operation of the attenuator. The minimum gross vehicular weight (GVW) (actual weight) for each truck shall comply with these specifications unless otherwise directed within the "Remarks" column of the *Approved Products List For Traffic Control Devices in Work Zones* in regard to specific requirements for the device in question.

If the addition of supplemental weight to the vehicle as ballast is necessary, contain the material within a structure constructed of steel. Construct this steel structure to have a minimum of four sides and a bottom to contain the ballast material in its entirety. A top is optional. Bolt this structure to the frame of the truck. Utilize a sufficient number of fasteners for attachment of the steel structure to the frame of the truck to ensure the structure will not part from the frame of the truck during an impact upon the attached truck mounted attenuator. Utilize either dry loose sand or steel reinforced concrete for ballast material within the steel structure to achieve the necessary weight. The ballast material shall remain contained within the confines of the steel structure in its entirety and shall not protrude from the steel structure in any manner.

2.6.8 Trailer-Mounted Changeable Message Signs (Sub-section 606.3.2) -

Sub-section 606.5 Measurement (paragraph 2) -

Trailer-mounted changeable message signs are included in the lump sum item for Traffic Control in accordance with **Subsections 107.12** and **601.5** of the "2007 Standard Specifications for Highway Construction". No separate measurement will be made for trailer-mounted changeable message signs unless the contract includes a specific pay item for trailer-mounted changeable message signs.

The Contractor shall provide, install, operate, and maintain the trailer-mounted changeable message sign per traffic control set-up as directed by the Plans, the "Standard Drawings for Road Construction", these Special Provisions, the Specifications, and the Engineer.

Sub-section 606.6 Payment (paragraph 2) -

In addition to **Subsections 107.12** and **601.6**, the payment for Traffic Control is full compensation for providing, installing, removing, relocating, operating, and maintaining trailer-mounted advance warning arrow panels and trailer-mounted changeable message signs as specified

or directed and includes providing the units' primary power source; repairing or replacing damaged or malfunctioning units within the specified time; providing traffic control necessary for installing, operating, and maintaining the units; and all other materials, labor, hardware, equipment, tools, supplies, transportation, incidentals, and any miscellaneous items necessary to fulfill the requirements of the pay item in accordance with the Plans, the Specifications, and other items of the Contract.

Sub-section 606.6 Payment (paragraph 3) -

Disregard this paragraph unless the Contract includes a specific pay item for trailer-mounted changeable message signs.

2.6.9 Temporary Pavement Markings (Sub-section 609.4.1) –

Sub-section 609.4.1.1.1 Application Requirements General (in addition to paragraph 3) -

On two-lane two-way roadways, apply and place temporary or permanent pavement markings, as specified hereupon, prior to the end of each day's work or shift or reopening a closed travel lane to traffic. These pavement markings shall include 4-inch wide solid lines on edge lines and solid center lines and 4-inch wide by 10 feet long broken lines with a 30-foot gap for broken center lines and lane lines unless otherwise specified. The center line pavement markings shall be either double yellow solid lines, yellow broken lines or an appropriate combination of a yellow solid line and yellow broken lines for passing / no passing zones. Placement of a singular yellow solid line for a center line pavement marking is unacceptable. The edge line pavement markings shall be a white solid line.

On multilane primary and secondary roadways, apply and place temporary or permanent pavement markings, as specified hereupon, to the travel lanes prior to reopening a closed travel lane to traffic. These pavement markings shall include 4-inch wide solid lines, utilized for edge lines and solid center lines, and 4-inch wide by 10 feet long broken lines with a 30-foot gap, utilized for lane lines and turn lanes, unless otherwise specified. The center line pavement markings shall be either double yellow solid lines or an appropriate combination of a yellow solid line and 4-inch wide by 10 feet long yellow broken lines for two-way left turn median areas. The right edge line pavement markings shall be a white solid line and the left edge line shall be a yellow solid line except in areas where the travel lanes separate to create a gore type situation and then the color schemes shall comply with SCDOT application practices for gore areas. The lane

lines between travel lanes and turn lanes shall be 4-inch wide by 10 feet long white broken lines with a 30-foot gap.

However, on two-lane two-way and multilane primary and secondary roadways, application of a 4-inch wide solid line utilized for an edge line adjacent to an earth shoulder, white or yellow, may be delayed up to 72 hours after eradication of the original line when the length of eradicated line at a single location is no longer than 250 feet. In the event of multiple locations along the same line, each location must be separated from the adjacent location by no less than 250 feet with a cumulative total distance of eradicated line of no more than 1300 feet within any continuous 1 (one) mile length of roadway measured from a selected location. If the length of eradicated line exceeds 250 feet at any single location, the distance interval between multiple adjacent locations is less than 250 feet or a cumulative total distance of multiple locations of eradicated line exceeds 1300 feet within any continuous 1 (one) mile length of roadway measured from a selected location, replace the eradicated line(s) prior to reopening the adjacent travel lane to traffic.

On interstate roadways, apply and place temporary or permanent pavement markings, as specified hereupon, to the travel lanes prior to reopening a closed travel lane to traffic. These pavement markings shall include 6-inch wide solid lines, utilized for edge lines, and 6-inch wide by 10 feet long white broken lines with a 30-foot gap, utilized for lane lines between travel lanes and auxiliary lanes, unless otherwise specified. The right edge line pavement markings shall be a white solid line and the left edge line shall be a yellow solid line except in areas where the travel lanes separate to create a gore type situation and then the color schemes shall comply with SCDOT application practices for gore areas.

On all roadways, apply and place white stop bars and white triangle yield bars in all locations where previous stop bars and triangle yield bars have been eradicated by the work. Apply and place white stop bars and white triangle yield bars at intersections controlled by stop and yield signs within 72 hours of the eradication of the original pavement marking. Apply and place white stop bars at signalized intersections controlled by traffic control signals and at railroad crossings prior to reopening a closed travel lane to traffic.

Within the limits of existing turn lanes on all roadways, apply and place white arrows in all locations where previous arrows have been eradicated by the work unless otherwise directed by the RCE. Apply and place white arrows within 72 hours of the eradication of the original pavement markings. However, in regard to newly constructed turn lanes, apply and place white arrows the within turn lanes as directed by the RCE.

Within the limits of existing lane-drop sites on all roadways, apply and place white arrows in all locations where previous arrows have been eradicated by the work prior to the end of each day’s work or shift or reopening the closed travel lane to traffic. In regard to newly constructed lane-drop sites, apply and place white arrows within the travel lane to be terminated prior to opening the travel lane to traffic and as directed by the RCE.

2.6.10 Flagging Operations (Sub-section 610.4.1) –

Sub-section 610.4.1.1 Flagging Operations (paragraph 1) -

Use a flagging operation to control the flow of traffic when two opposing directions of traffic must share a common travel lane. A flagging operation may be necessary during a lane closure on a two-lane two-way roadway, an intermittent ramp closure or an intermittent encroachment of equipment onto a portion of the roadway. Utilize flagging operations to direct traffic around work activities and maintain continuous traffic flow at reduced speeds when determined to be appropriate by the RCE. As stated above, flagging operations shall direct traffic around the work activities and maintain continuous traffic flow; therefore, stopped traffic shall not be required to stop for time durations greater than those listed below unless otherwise directed by the RCE. Begin measurement of the time interval immediately upon the moment the Flagger rotates the Stop/Slow paddle to display the “Stop” condition to the approaching motorists.

LENGTH OF CLOSURE	MAXIMUM TIME DURATION FOR STOPPED TRAFFIC
1 MILE or LESS	5 Minutes
1 to 2 MILES	7 ½ Minutes

If the work activities require traffic to be stopped for periods greater than 5 to 7 ½ minutes as stated above, consider alternate work methods, conducting work activities during times of lowest traffic volumes such as during the hours of darkness or complete road closure with detour installation.

2.6.11 Paving and Resurfacing (Sub-section 611.4.1) –**Sub-section 611.4.1.2 Requirements (paragraph 8) -**

Whenever travel lanes with acceptable grade elevation differences are open to traffic, provide “Uneven Lanes” signs (W8-11-48) or “Uneven Pavement” signs (W8-11A-48). Reflectorize these signs with a fluorescent orange colored prismatic retroreflective sheeting unless otherwise specified. Install these signs adjacent to roadways with uneven pavement surfaces between travel lanes or between travel lanes and the adjacent paved shoulders. Install these signs at intervals no greater than 2600 feet.

2.7 STAGING**2.7.1 Traffic Control Restrictions (Project Specific Widening and Rehabilitation)**

Maintain the existing number of I-77 mainline lanes of traffic in each direction during the times of the lane closure restrictions (3 lanes from I-20 southerly and SC 277 northerly, 2 lanes from I-20 to SC 277). Maintain the existing number of travel lanes for all on-ramps and off-ramps during the times of the lane closure restrictions unless otherwise approved by the Department. Ramp traffic must be maintained at all times, no detours allowed. All I-20, US 1, SC 277, and Killian Road ramps must maintain free-flow operation (no yield control) unless otherwise approved by the Department. Reference section 2.7.2 for the US 21 Bridge Rehabilitation including exceptions to the lane and ramp closure restrictions listed above.

Once the northbound I-77 at SC 277 merge is converted to a parallel type acceleration lane, it SHALL NOT return to the existing condition (middle lane shared merge) in future staging.

During the widening of the I-77 mainline bridges over I-20, 3-lanes shall be maintained on I-20 in each direction during the times of the lane closure restrictions. Consider widening the median along I-20 asymmetrically for the work area; widen as much as possible on eastbound I-20 to limit the impacts associated with the Alpine Road entrance ramp in the westbound direction. If the Alpine Road entrance ramp is reduced, it shall maintain a minimum 300' acceleration lane and 200' taper onto westbound I-20 unless otherwise directed by the Department.

The Contractor shall have no more than 72 hours to begin elimination of any grade elevation differences between or adjacent to the travel lanes of I-77. The 72 hour time period shall begin upon creation of the grade

elevation difference. This restriction shall apply to all acceptable grade elevation differences less than or equal to 1” in milled areas or less than or equal to 2” in paved areas.

During surface planing and milling operations, the length of roadway with a milled surface open to traffic is restricted to 4 miles. This restriction does not apply to concrete diamond grinding operations.

During surface planing and milling operations, the length of roadway with an acceptable grade elevation difference less than or equal to 1” adjacent to a single travel lane or between multiple travel lanes open to traffic is restricted to a maximum distance of 4 miles.

During asphalt paving operations, the length of roadway with an acceptable grade elevation difference less than or equal to 2” adjacent to a single travel lane or between multiple travel lanes open to traffic is restricted to a maximum distance of 4 miles.

The Contractor may conduct various work activities in the same direction at various locations concurrently if approved by the Department. Various work activities in the same direction requiring simultaneous closures in the same travel lane or shoulder shall be separated by no less than 2 miles from the end of the first closure that a motorist will encounter to the beginning of the taper of the second closure. Also, various work activities in the same direction requiring simultaneous right and left lane closures or shoulder closures shall be separated by no less than 4 miles from the end of the first closure that a motorist will encounter to the beginning of the taper of the second closure.

2.7.2 Traffic Control Restrictions (Project Specific US 21 Bridge Rehabilitation) -

Maintain 2-lanes of mainline I-77 traffic in each direction at all times during the US 21 bridge rehabilitation. If both lanes of southbound I-77 are diverted from the southbound bridge to the I-77 northbound bridge, then all traffic staging related to the bridge rehab will be limited to a maximum of 15 calendar days. If one lane of southbound I-77 mainline traffic is maintained on the southbound bridge and one lane is diverted to the I-77 northbound bridge, then all traffic staging related to the bridge rehab will be limited to a maximum of 30 calendar days. The Contractor is advised that this Staging Restriction will be strictly enforced. Should any staging related to the bridge rehabilitation remain in place or not be completely removed by the time listed above, a penalty will be assessed at the rate of \$5,000.00 (Five Thousand Dollars) for each 24 hour interval exceeded.

The existing posted speed limit prior to construction shall be used to design the crossovers for all temporary detour shifts and staging.

Loop ramps at the US 21 interchange must remain a free-flow movement into an acceleration lane onto the interstate. If the loop ramp acceleration lane is removed or reduced to a distance less than 400' and 200' taper, the loop ramp shall be closed. Traffic must be detoured from the loop to a newly constructed 12' wide left turn lane with 300 feet of storage in the median of US 21 and a connection made to the appropriate ramp. All new construction for the detour must meet current SCDOT design standards unless otherwise directed by the Department. ~~A temporary signal is expected at the new left turn lane on US 21 as a result of the southbound loop ramp detour. All SCDOT signal design standards and guidelines shall be followed for the temporary signal. The only exemption to these standards and guidelines shall be the use of wooden poles and video vehicle detection. The elements associated with the detour must be removed at the conclusion of the detour and traffic shifted back to the existing loop.~~

2.7.2.1 Temporary Signal

A temporary signal is expected at the new left turn lane on US 21 as a result of the southbound loop ramp detour. The signal shall be fully actuated and provide a phase for both the left turn onto the ramp and the left turn from the off-ramp. The right turn onto the on ramp shall be converted to a YIELD condition.

All SCDOT signal design standards and guidelines shall be followed for the temporary signal. The only exemption to these standards and guidelines shall be the use of wooden poles and video vehicle detection.

The elements associated with the detour must be removed at the conclusion of the detour and traffic shifted back to the existing loop. Raised concrete islands shall be constructed to prevent traffic from making this turn after removal.

3.0 DELIVERABLES

3.1 Traffic Management Plan

The Contractor shall submit a Traffic Management Plan in accordance with the document, *Rule on Work Zone Safety and Mobility: Implementation, Maintenance, and Safety Guidelines*. All components of the Transportation Management Plan prepared by the CONTRACTOR are required and shall be

submitted for review by the Department ~~before approval~~ and shall be approved before any construction activities can begin.

3.2 Conceptual Work Zone Traffic Control Plans

The Contractor shall submit Conceptual Work Zone Traffic Control Plans in the Right-of-Way Plans. The plans shall include, but not be limited to, the following:

- Staging Narrative
- Concept Staging Plans
 - Widening/Rehabilitation Typical Sections for each Stage of Construction and any critical points
 - Show areas where additional Right-of-Way is warranted for the purposes of Staging
 - Show the Separation of Adjacent Travel Lanes / Traffic Splits as described in the SCDOT Procedures and Guidelines for Work Zone Traffic Control Design
 - Show areas where the travel lane leaves the existing roadway bed or direction on new alignment (transition area) and returns (termination area)

3.3 Work Zone Traffic Control Plans

The Contractor shall submit **Conceptual** Work Zone Traffic Control Plans in the Right-of-Way Plans **Submittal** and **Work Zone Traffic Control Plans (including Temporary Signal Plans)** in the Final Plans **Submittal**. The plans shall be in accordance with the SCDOT Procedures and Guidelines for Work Zone Traffic Control Design and all other applicable design references listed in Exhibit 4.

EXHIBIT 4d

TRAFFIC DESIGN CRITERIA

Part 3 – Traffic Signals

1.0 GENERAL

The Contractor shall repair and maintain all signal related equipment during the construction of this project. During the ramp rehabilitation it is anticipated that there will be impacts associated to the detection at the traffic signals listed below. The project should include any temporary detection measures (such as video detection cameras) that would be required if damage to the existing inductive loops occurs during this project. In addition, once the rehabilitation is completed, the **damaged** inductive loops should be replaced in accordance with the latest SCDOT design standards for stop bar loops.

In addition to maintaining the detection, any work at the ramps that impact the traffic signal, such as damage to fiber interconnect or any other signal appurtenances, shall be immediately repaired/replaced to SCDOT standards. Coordination with the District 1 Signal Staff should occur to ensure the work will avoid damaging traffic signal utilities as much as is feasible.

The intersections involved are shown in the list below. **Maintain detection at ALL times.**

- I-77 SB @ US 1 (Two Notch)
- I-77 NB @ US 1 (Two Notch)
- I-77 SB @ SC 555 (Farrow Rd)
- I-77 NB @ SC 555 (Farrow Rd)
- I-77 NB @ S-52 (Killian Rd)
- I-77 SB @ S-52 (Killian Rd)

2.0 CRITERIA

All criteria listed in Exhibit 5 and all other applicable design references in Exhibit 4 shall be incorporated into the signal design, maintenance, and construction.

3.0 DELIVERABLES

3.1 As-Built Signal Plans

Provide As-Built “red-lined” signal plans to the District Signal Shop after the signal work is completed.

EXHIBIT 4d

TRAFFIC DESIGN CRITERIA

Part 4 – Intelligent Transportation System

1.0 GENERAL

The CONTRACTOR is not responsible for the maintenance or construction of ITS elements. ITS elements have been installed within the limits of this project. The CONTRACTOR shall call PUPs for locating the existing ITS underground infrastructure. Contact the ITS Field Operations Manager at 1408 Shop Road (803) 737-1163 or the ITS Coordinator at 1412 Shop Road (803) 737-1646 for information concerning the existing ITS infrastructure within this project.

The Final As-Built ITS Plans will be provided to the CONTRACTOR once completed.

EXHIBIT 4e

HYDRAULIC DESIGN CRITERIA

1.0 GENERAL

All hydrologic and hydraulic drainage designs associated with this project shall be performed in accordance with the “SCDOT’s Requirements for Hydraulic Design Studies”, May 2009, Water Quality Design Manual, and the Project Design Criteria as listed in EXHIBIT 4. Designs to be addressed include:

- Ditch Stability
- Storm Sewer Systems
- Cross-line Pipes and Non-Bridge Sized Culverts
- Bridge-Sized Culverts and Bridges
- Scour
- Sediment and Erosion Control
- Best Management Practices
- Stormwater Quality Design

2.0 CRITERIA

The Stormwater Management Design Report (SMDR) prepared by HDR, dated May 2015 and received by the SCDOT on May 7, 2015, contains hydrological and hydraulic information for **the widening section** of this project and is included under ATTACHMENT B. This report provides direction for repair and/or replacement of existing pipes, culverts, inlets and corrective actions required for outfalls **from MM 15.0 to MM 21.5**.

2.1 Roadway Drainage, MM 15.0 to MM 21.5

- 2.1.1 The Contractor shall evaluate roadway and offsite drainage at locations where: additional imperviousness will be constructed, to include roadway and bridge widenings, the road crown will be shifted, temporary drainage will be affected by staging (to include underpasses), existing flood-prone areas and outfalls have been noted, and replacement of existing drainage structures is required, at a minimum.
- 2.1.2 The Contractor shall perform hydraulic analyses on all cross-drainage structures, to include those originating from median ditches. The analyses shall include the 100-yr storm event for overtopping and the 50-yr storm event for surcharging at median inlets.
- 2.1.3 Interstate ramps shall be considered primary roads for drainage design.
- 2.1.4 The drainage design and road profile shall take into account the backwater effects of any natural dams or other downstream controls.

- 2.1.5 When design calculations indicate an existing pipe/culvert requires upsizing and it discharges to wetlands areas, the SCDOT’s Environmental Office shall be notified.
- 2.1.6 The Contractor shall ensure temporary drainage systems are in place during staging and ponding is minimized. These systems shall be designed for the 5-yr storm event. Additional attention shall be given to expected spread areas, in particular for areas that are flood sensitive and on the low side of barrier walls.
- 2.1.7 The Contractor is directed to Section 4.10 and Table 4.10 of the SMDR for information on existing median inlets that have been inspected. If the inlets noted below are to be retained, the Contractor shall:

Inlet ID	Requirements for retained inlets
EX-0801	Bring existing ground up to rim elevation. Install paved apron.
EX-0901	Replace paved apron.
EX-1404	Excavate and replace subgrade adjacent to box. Replace paved apron.
EX-1501	Excavate and replace subgrade adjacent to box. Replace paved apron.
EX-1607	Clear and grub around adjacent to inlet. Install paved apron.
EX-1701	Excavate and replace subgrade adjacent to box. Replace paved apron.

- 2.1.8 The Contractor shall perform the necessary repairs and/or rehabilitations to existing inlets/junctions that have not been inspected but are to be retained.
- 2.1.9 The Contractor shall incorporate existing underdrainage systems as shown on the as-built plans, as well as others that may be present and not noted, in the drainage designs.
- 2.1.10 The Contractor shall meet the Railroad’s requirements when impacts due to construction occur within their right-of-way or outfalls discharge to the Railroad’s right-of-way. When applicable, prepare a report summarizing the pre- and post- runoff conditions for ditches and drainage structures within the Railroad’s right-of-way. A copy of the report shall also be submitted to SCDOT Right-of-Way Office – Railroad Coordinator.

2.2 Pipes and Culverts

- 2.2.1 For existing pipes and culverts inspected from MM 15.0 to MM 21.5 within the project limits, the Contractor is directed to the below table

EXHIBIT 4e – HYDRAULIC DESIGN CRITERIA

column heading “Evaluation of Pipe”, for direction regarding repair or replacement. The Contractor shall:

- Repair the pipe/culvert as noted or replace any pipe/ culvert in lieu of repair. When structural liners are used for repairs, the analyses shall reflect the “n” value for the liner material and any reduction in diameter.
- Verify hydraulic capacity of the pipes/culverts through hydraulic analyses performed by a SC Registered Professional Engineer to demonstrate compliance with the Hydraulic Design Requirements and Project Design Criteria. When analyses do not demonstrate compliance, the pipes shall be replaced or improvements made to the system.
- Refer to Table 4.9 for the preliminary hydraulic analyses of existing cross-line structures.
- Obtain necessary permits to perform the replacement or repairs.

Pipe ID	I-77 Station	Pipe / Culvert Type	Measured Footage (ft)	Evaluation of Pipe
EC-0102	1152+00	6' x 6' Conc. Box Culvert	1660	Patch cracks in culvert (approximately 94 locations).
EC-0103	1152+00	6' x 6' Conc. Box Culvert	596	Clean sediment buildup throughout. Patch cracks in culvert (approximately 17 locations).
EC-0211	1152+00	8' x 6' Conc. Box Culvert	2087	Headwall in good condition. Patch cracks in culvert (approximately 140 locations). Clean sediment build-up from 2080' to end.
EP-0302	1173+55	18" RCP	153.1	If existing pipe is to remain, repair last joint located 8' prior to downstream end. Preliminary hydro analysis indicates that additional capacity may be needed at this location.
EP-0305	1181+00	18" RCP	124.3	Pipe in good condition.
EP-0306	1187+35	48" RCP	673.3	Pipe in good condition.
EP-0401	1187+80	24" RCP	79.7	Remove root issue at first joint 5' from downstream end.
EP-0402	1192+50	42" RCP	512.9	Remove medium root issue at joint approx. 323' from downstream end. Remove and replace cracked pipe from approx. 387'-403' from downstream end.

EXHIBIT 4e – HYDRAULIC DESIGN CRITERIA

EP-0403	1187+65	18" RCP	101.9	Pipe in good condition.
EP-0404	1201+10	42" RCP	376.7	Slip line existing pipe due to joint deficiencies and minor root issues.
EP-0405	1198+00	18" RCP	133.4	Pipe in good condition.
EP-0406	1198+60	18" RCP	136.9	Repair first joint of existing pipe 8' from upstream end.
EP-0407	1192+85	18" RCP	111.4	8' of existing pipe prior to downstream end shall be replaced.
EP-0408	1197+40	42" RCP	492.6	Slip line existing pipe due to joint deficiencies and minor root issues.
EP-0503	1204+40	42" RCP	332	Slip line existing pipe due to joint deficiencies.
EP-0504	1204+25	36" RCP	30.9	Pipe in good condition.
EP-0505	1204+70	24" RCP	85.3	Slip line existing pipe due to cracks and joint separations.
EP-0506	1205+05	18" RCP	107	Pipe in good condition.
EP-0507	1206+10	18" RCP	129.9	Pipe in good condition.
EP-0508	1205+90	18" RCP	68.5	Pipe in good condition. Clean debris from both ends.
EP-0613	1229+50	18" RCP	101.2	Replace existing pipe section between approx. 23' and 31' from upstream end and repair separated/broken joint at approx. 88' from upstream end.
EP-0614	1230+00	18" RCP	69.3	Pipe in good condition.
EP-0701	1236+00	18" RCP	195.6	Slip line existing pipe due to joint deficiencies and cracks. Repair slope failure in vicinity of and above outlet pipe.
EP-0702	1246+60	18" RCP	104.1	76' of existing pipe prior to outlet shall be replaced due to cracks in pipe and major joint separations.
EP-0801	1252+00	18" RCP	180	Pipe in good condition.
EP-0802	1253+25	24" RCP	242.8	Slip line existing pipe due to joint separations.
EP-0803	1261+45	18" RCP	199.2	Pipe in good condition. Clean out.
EP-0901	1270+50	18" RCP	167.7	8' of existing pipe prior to outlet shall be replaced due to cracked pipe with hole in it.
EC-0906	1273+15	7.5' x 5' Conc. Box Culvert	240	Patch cracks in culvert (approximately 13 locations).
EP-1002	1286+60	30" RCP	367.3	Pipe in good condition.
EP-1003	1286+45	24" RCP	84.9	Pipe in good condition.
EP-1004	1286+35	24" RCP	84.8	Pipe in good condition.

EXHIBIT 4e – HYDRAULIC DESIGN CRITERIA

EP-1005	1286+40	24" RCP	62.2	Pipe in good condition.
EP-1006	1289+60	24" RCP	305	Replace first 32' of existing pipe from upstream end due to root issues and broken pipe.
EP-1007	1290+50	18" RCP	108	Pipe in good condition.
EP-1008	1290+05	18" RCP	99.5	Pipe in good condition.
EP-1010	1283+70	30" RCP	384.5	Clean out.
EP-1101	1297+50	18" RCP	97.7	Slip line existing pipe due to joint separations.
EP-1102	1297+50	24" RCP	91.3	Pipe in good condition.
EP-1103	1296+55	18" RCP	16.8	20' of existing pipe from upstream end shall be replaced due to collapse and deficiencies. Clean pipe.
EP-1104	1297+45	24" RCP	111.7	Replace pipe due to cracks, major root issues, and joint separations.
EP-1105	1298+55	24" RCP	65.8	Replace pipe due to joint deficiencies and major root issues.
EP-1106	1299+15	24" RCP	53.9	Pipe in good condition. Clean downstream pipe end and drop inlet.
EP-1111	1304+40	24" RCP	266.9	Pipe in good condition.
EP-1114	1303+60	24" RCP	312.6	Pipe in good condition.
EP-1201	1320+10	24" RCP	108.2	Clean out.
EP-1202	1320+00	18" RCP	110.5	Pipe in good condition.
EP-1203	1323+40	36" RCP	686	Pipe in good condition.
EP-1204	1327+70	36" RCP	93.4	Slip line existing pipe due to joint deficiencies.
EP-1301	1332+20	24" RCP	171.5	Pipe in good condition.
EP-1302	1341+90	24" RCP	116.1	Pipe in good condition.
EP-1303	1342+10	18" RCP	115.8	If retained, clean pipe (large debris item near 75' from upstream end). Preliminary hydro analysis indicates that additional capacity may be needed at this location.
EP-1401	1350+05	18" RCP	264.6	Pipe in good condition.
EP-1402	1352+05	18" RCP	224.7	Pipe in good condition.
EP-1403	1353+85	30" RCP	127.8	Pipe in good condition.
EP-1404	1355+00	30" RCP	101.6	Pipe in good condition.
EP-1405	1355+40	36" RCP	187.8	Clean out.
EP-1406	1357+50	24" RCP	363.4	Replace first section of pipe due to major joint offset. Pipe in good condition otherwise. Clean out.
EC-1407	1358+00	6' x 5' Conc. Box Culvert	440	Headwalls in good condition. Patch cracks in culvert (approximately 35 locations). Clean downstream sediment buildup.

EXHIBIT 4e – HYDRAULIC DESIGN CRITERIA

EP-1408	1357+85	18" RCP	180.5	Slip line existing pipe due to joint deficiencies and major root issues.
EP-1409	1358+25	18" RCP	214.8	Slip line existing pipe due to joint separations.
EP-1501	1362+45	18" RCP	136.7	Pipe in good condition.
EC-1503	1366+80	4' x 4' Conc. Box Culvert	680.5	Patch cracks in culvert (approximately 41 locations). Repair connection with EP-1599 at approx. 385' from downstream end.
EP-1506	1372+00	18" RCP	134.5	Pipe in good condition.
EP-1507	1372+00	18" RCP	51.1	Pipe in good condition.
EP-1601	1379+80	18" RCP	35.9	Pipe in good condition. Clean debris from pipe and box catch basin at upstream end.
EP-1602	1379+80	18" RCP	106.2	Remove root issues at first joint approx. 8' from downstream end and second joint approx. 16' from downstream end. Clean pipe.
EP-1603	1379+85	18" RCP	121.9	Pipe in good condition.
EP-1604	1379+85	24" RCP	50.1	Pipe in good condition.
EP-1606	1383+85	30" RCP	400.6	Pipe in good condition.
EP-1607	1383+45	18" RCP	39.8	Slip line existing pipe due to joint separations.
EP-1608	1383+50	18" RCP	105.4	Remove and replace pipe 13' from downstream end to repair major root issues in joints. Clean pipe.
EP-1609	1383+65	18" RCP	122.1	Remove and replace pipe between 30' from upstream end to repair major root issues in joints. Clean pipe.
EP-1610	1383+80	24" RCP	53.5	Pipe in good condition.
EP-1701	1399+90	18" RCP	171	10' of existing pipe prior to downstream end shall be replaced due to joint separations and offsets.
EC-1702	1407+70	8' x 6' Conc. Box Culvert	280	Headwall in good condition. From upstream end, repair top of culvert where square block of concrete is giving way at approx. 70'. Patch cracks in culvert (approximately 6 locations).
EC-1703	1407+70	8' x 6' Conc. Box Culvert	280	Headwalls in good condition. Patch cracks in culvert (approximately 8 locations).
EC-1704	1407+70	8' x 6' Conc. Box Culvert	280	Headwalls in good condition. Patch cracks in culvert (approximately 4 locations). Clean sediment buildup at downstream end.

EXHIBIT 4e – HYDRAULIC DESIGN CRITERIA

EP-1801	1416+20	24" RCP	147.9	Pipe in good condition. Clean pipe. Standing water and sediment in pipe from outfall OP-1896 silting in.
EP-1802	1416+50	24" RCP	115.5	Repair joint separations at approx. 16' and 24' from upstream end.
EP-1803	1423+70	30" RCP	154.5	Pipe in good condition. Clean pipe. Standing water and sediment in pipe from outfall OP-1895 silting in.
EP-1804	1424+10	30" RCP	122.2	Pipe in good condition. Preliminary hydro analysis indicates that additional capacity may be needed at this location.
EP-1806	1410+75	24" RCP	130.4	Pipe in good condition.
EP-2101	1458+55	36" RCP	133.7	Pipe in good condition. Preliminary hydro analysis indicates that additional capacity may be needed at this location.
EP-2102	1459+00	36" RCP	101.4	Pipe in good condition. If retained, clean pipe. Standing water and sediment in pipe from outfall OP-2199 silting in. Preliminary hydro analysis indicates that additional capacity may be needed at this location.
EC-2103	1468+95	12' x 12' Conc. Box Culvert	288	Headwall in good condition. Patch cracks in culvert (approximately 6 locations).
EP-2104	1471+90	18" RCP	156.2	Repair joint separations at approx. 4' and 12' from downstream end.
EC-2105	1468+95	12' x 12' Conc. Box Culvert	288	Headwall in good condition. Patch cracks in culvert (approximately 9 locations).
EC-2106	1468+95	12' x 12' Conc. Box Culvert	288	Headwall in good condition. Patch cracks in culvert (approximately 7 locations). Clean sediment buildup throughout culvert.
EP-2201	1475+65	24" RCP	159.2	Pipe in good condition.
EP-2202	1476+70	24" RCP	152.2	Pipe in good condition.
EP-2203	1485+00	36" RCP	145.8	Pipe in good condition.
EP-2204	1485+95	36" RCP	138.9	Pipe in good condition. Large HDPE pipe debris inside of drop inlet EX-2204 and upstream end of EP-2204. If retained, clean entire pipe of sediment and debris.

EXHIBIT 4e – HYDRAULIC DESIGN CRITERIA

EP-2301	1500+90	24" RCP	43.5	Pipe in good condition. Clean pipe. Standing water and sediment in pipe from outfall OP-2399 silting in.
EP-2303	1503+95	18" RCP	142.3	8' of existing pipe prior to outlet shall be replaced due to collapse. Slip line existing pipe due to joint separations and deficiencies.
EP-2403	1499+95	24" RCP	21.3	Pipe in good condition. Clean pipe. Standing water in pipe.
EP-2404	1522+40	18" RCP	61.7	Remove and replace last segment of pipe at downstream end to repair major root issues in joint.

2.2.2 For existing pipes not inspected from MM 15.0 to MM 21.5 within project limits that will be retained, the Contractor shall:

- Provide video inspection reports to verify structural soundness.
- Perform the necessary repairs and/or rehabilitations as required.
- Verify hydraulic capacity of the pipes through hydraulic analyses performed by a SC Registered Professional Engineer to demonstrate compliance with the Requirements and Design Criteria. When analyses do not demonstrate compliance, the pipes shall be replaced or improvements made to the system.
- Obtain necessary permits to perform the replacement or repairs.

2.2.3 For existing pipes that will be lengthened from MM 21.5 to MM 27.0 Southbound, the Contractor shall verify the structural integrity of the pipes per SCDOT EDM 24. All pipes retained shall be cleaned of all debris and video inspected prior to acceptance of the project.

2.2.4 All pipes that are to be abandoned shall be filled with flowable fill.

2.2.5 Traffic control needs to be considered when working on, to include cleaning, the pipes and culverts.

~~2.2.6 The Contractor shall verify structural integrity of the pipe when existing pipe is to be lengthened or retained.~~

2.2.67 The Contractor shall implement corrective actions to fix the existing scour holes at inlet EX-1796 of EC-1702 and inlet EX-2196 of EC-2103 and. ~~The Contractor~~ shall be responsible for any permitting requirements.

2.3 Hydraulic Modeling, MM 15.0 – MM 21.5

2.3.1 The Contractor shall model natural, existing, and proposed conditions for bridges and/or bridge-sized culverts that are to be replaced, widened,

and/or extended over stream crossings using the 1-D model HECRAS. Refer to the HEC-RAS Reference Manual v4.1 or latest edition for guidance on setting up cross sections and other inputs within the model. In addition to the four cross sections described within the Manual, add additional cross sections as necessary to achieve a downstream limit where a change in starting elevation will not affect the computed high-water depth at the bridge and the upstream limit extends to the limit of backwater from the bridge.

- 2.3.2 The preliminary model setup shall be approved by the SCDOT before finalizing the model. Summarize model inputs, results, include beginning and end stations for the structure, the finished grade and low chord elevations.
- 2.3.3 The Contractor shall compare model results for the proposed conditions to the unrestricted (natural conditions) for the 100-yr storm event to show 1.0 ft or less of backwater.
- 2.3.4 The Contractor shall demonstrate through modeling that 2.0 ft of freeboard exists between the 50-yr design storm event and the low chord for bridge structures and 2.0 ft of freeboard exists between the 50-yr design storm event and the inside top of bridge-sized culverts.
- 2.3.5 HECRAS models are included under Attachment B for information. These models have been setup for the bridges and the bridge-sized culverts at Jackson, Little Jackson, Crane and Cumbess Creeks. The models indicate the bridge-sized culverts at Cumbess and Crane Creeks do not meet the required 1.0 ft of backwater and 2.0 feet of freeboard for the 100-yr and 50-yr storm events respectively. The Contractor shall demonstrate through modeling that the proposed headwater and flow rates at the upstream end of these two crossings are equal to or less than those of existing conditions. The Contractor shall not alter the existing lengths and sizes of these existing culverts. If these conditions are met, design variances shall not be required for backwater and freeboard at these two crossings.
- 2.3.6 The Contractor shall prepare a scour study for each structure that is hydraulically modeled.

2.4 Floodplains and Floodways

- 2.4.1 The Contractor shall minimize impacts within the Special Flood Hazard Areas (SFHA) defined by FEMA as Zones A or AE on the Richland County FIRM maps during construction. There are four regulated stream crossings within the project limits. Richland County maps are currently being updated. The Contractor is responsible to coordinate

with the County and FEMA to ensure the maps being used are the most current ones available throughout the design and construction process.

2.4.2 When impacts occur within these SFHAs, the Contractor shall coordinate with the appropriate agencies in accordance with the “SCDOT’s Requirements for Hydraulic Design Studies”, May 2009 and obtain the necessary approvals and/or certifications that are required.

~~2.4.3 The Contractor shall coordinate with FEMA and the Local Agencies as needed throughout the review process to ensure the Flood Insurance Rate Maps (FIRM) maps and stream models are updated.~~

2.5 Outfalls, MM 15.0 – MM 21.5

2.5.1 The Contractor shall include treatment at outfalls through vegetative practices where possible and utilize structural controls when vegetative practices are not applicable.

2.5.2 Outfalls shall be evaluated for post-construction treatment on a case specific basis against the Maximum Extent Practicable standard (control measures are designed to be effective as possible given financial, social, and right-of-way constraints).

2.5.3 For existing outfalls that have not been inspected, the Contractor shall perform the necessary repairs and/or rehabilitations as required.

2.5.4 The Contractor is directed to Section 4.12 of the SMDR for existing outfall information. The outfalls (stations approximated) listed below shall be cleaned and/or reworked as recommended below.

Station	Outlet Number	Offset	Recommendation	Right-of-Way Concerns
1151+85	OP-0100	188’ RT	Remove sediment.	No
1167+30	OP-0286	146’ RT	Excavate buried pipe end and beyond to ensure positive drainage.	No
1171+30	OP-0398	200’ RT	Excavate buried pipe end, remove sediment and vegetation to ensure positive drainage. Right-of-issues may exist.	Yes
1177+35	OP-0394	118’ LT	Remove debris in ditch.	No
1224+45	OP-0683	115’ RT	Locate outfall and excavate to ensure positive drainage.	No
1246+60	OP-0798	155’ RT	Locate outfall, replace collapsed pipe, and excavate to ensure positive drainage.	No

EXHIBIT 4e – HYDRAULIC DESIGN CRITERIA

1236+00	OP-0799	155' RT	Repair slope failure in vicinity of and above outfall pipe.	No
1259+70	OP-0897	93' RT	Clean concrete channel downstream of outfall approximately 470'.	No
1271+65	OP-0999	118' LT	Outfall pipe and ditch partially silted in. Clean and re-excavate to the edge of right-of-way.	No
1278+00	OP-0995	119' LT	Remove vegetation and debris and re-excavate to the edge of right-of-way.	No
1281+80	OP-1010	117' LT	Clean and re-excavate to the edge of right-of-way.	No
1332+10	OP-1396	166' RT	Remove tree at pipe outlet.	No
1347+75	OP-1499	134' LT	Remove vegetation in ditch to re-establish positive drainage within existing right-of-way.	No
1364+80	OP-1598	129' RT	Remove debris at baffles along concrete outlet apron of box culvert within existing right-of-way, within the I-77/I-277 interchange.	No
1379+05	OP-1699	263' RT	Locate outfall and excavate to ensure positive drainage.	Yes
1396+05	OP-1799	201' RT	Remove sediment from pipe and re-excavate approximately 25' between pipe end and concrete lined channel.	No
1423+20	OP-1895	148' LT	Re-excavate approximately 20' between pipe end and downstream ditch.	No
1433+10	OP-1999	121' LT	Remove sediment and debris. Re-excavate to ensure positive drainage.	No
1433+15	OP-1998	123' RT	Remove sediment and debris. Re-excavate to ensure positive drainage.	No
1451+70	OP-1896	170' LT	Re-excavate to ensure positive drainage. Right-of-way issues may exist.	Yes
1459+55	OP-2199	162' LT	Remove sediment and debris to ensure positive drainage. Right-of-way issues may exist.	Yes
1472+25	OP-2195	162' LT	Remove sediment and debris to ensure positive drainage. Right-of-way issues may exist.	Yes
1474+60	OP-2299	114' LT	Remove sediment and debris to ensure positive drainage.	No

EXHIBIT 4e – HYDRAULIC DESIGN CRITERIA

1484+00	OP-2298	162' LT	Remove sediment and debris to ensure positive drainage. Right-of-way issues may exist.	Yes
1499+65	OP-2398	175' LT	Locate outfall and re-excavate to ensure positive drainage.	No.
1500+30	OP-2399	147' RT	Remove sediment and debris to ensure positive drainage.	No
1503+15	OP-2397	239' LT	Fix/Replace last pipe joint. Re-excavate to ensure positive drainage.	No
1505+50	OP-2396	310' LT	Re-excavate to ensure positive drainage.	No

2.6 Sediment and Erosion Control

- 2.6.1 The Contractor shall develop a plan that outlines methods for minimizing the amount of erosion and sedimentation during construction for the *entire* project length, to include the Southbound lane from MM 21.5 to 27.0. ~~stations where no new imperviousness will be constructed.~~
- 2.6.2 The plan shall be summarized on the Erosion Control Data Sheet(s) (ECDS) that are to be included within the construction plans. Inlet filter locations shall be noted on the drainage sheets.
- 2.6.3 The Contractor shall ensure sufficient right-of-way has been allocated to properly maintain erosion and sediment control measures during construction and post-construction.
- 2.6.4 The Contractor shall perform the necessary repairs and/or rehabilitations ~~as required~~ to existing slope failures and/or washouts, and specifically, in the vicinity of SB I-77 before the I-20 bridge on the right side. ~~Prior to performing these repairs, the CONTRACTOR shall obtain the RCE's approval of the repair and/or rehabilitation methods.~~

2.7 NPDES Permitting

- 2.7.1 The Contractor is responsible for the preparation of the NPDES permit package. The package includes:
- Notice of Intent (NOI)
 - Stormwater Pollution Prevention Plan (SWPPP)
 - SCDOT/SCDHEC checklist
 - A half-sized set of signed and sealed final drainage plans
- 2.7.2 The SCDOT will review, sign and submit the package to SCDHEC. The Contractor is responsible for all required coordination to obtain the permit.

- 2.7.3 When TMDLs are identified on the NOI, the Contractor shall ensure that the discharge will not further contribute to the impairment or will comply with the TMDL by implementing appropriate BMPs.

3.0 DELIVERABLES

All submittals shall be subjected to a thorough QC review by the Contractor prior to submitting to the SCDOT and shall be signed and sealed by the Engineer of Record, a licensed and registered Professional Engineer in the State of South Carolina.

3.1 Preliminary Hydraulic Design Submittal

The Contractor shall submit to the SCDOT:

- One (1) Set of Preliminary Roadway Drainage Plans
- One (1) Hard Copy and Electronic Copy of the Preliminary Hydraulic Design Report, to include:
 - Roadway Drainage Design and Supporting Documentation, to include flowrates, inlet spacing calculations, Hw/D, geopak summaries, outlet protection
 - Sediment and Erosion Control Plan and Supporting Documentation
 - Preliminary Hydraulic Model Design and Supporting Documentation (for each applicable location), to include a summary of the design flow rates, design storm event freeboard and backwater
 - Address Permitting Requirements associated with Federal, State and Local Agencies
 - ~~Anticipated~~ Design Exception Request(s), when applicable
 - Railroad Coordination (if applicable)

3.2 Final Hydraulic Design Submittal

The Contractor shall submit to the SCDOT:

- Two (2) Hard Copies of the CLOMR and/or “No Impact” Certification and Supporting Documentation, when applicable
- Three (3) Hard Copies of the NPDES Permit Package (and 1 additional copy of the NOI)
- One (1) Hard Copy and One (1) Electronic Copy of the Final Hydraulic Design Report and Final Drainage Plans.
 - Finalized Version of the Preliminary Design Report
 - Scour Study and Supporting Documentation (for each applicable location)
 - Drainage Plan Sheets shall include Inlet Filter Types and Locations for all Existing and Proposed Inlet Structures.

EXHIBIT 4f

GEOTECHNICAL DESIGN CRITERIA

1.0 GENERAL

The following items, at a minimum, shall be included in the geotechnical design for this project:

- Design foundations for the proposed 10 bridge structure widenings. All subsurface exploration, geotechnical design, and construction for the Project shall be carried out in accordance with the design criteria below.
- Evaluate new pavement subgrades within the proposed widening sections of the I-77 mainline and any other proposed new pavements on the project.
- As necessary, provide pile and drilled shaft dynamic and/or static load testing as outlined in the design criteria and in accordance with the project specifications and Special Provisions. The results shall be used to determine capacities of the associated foundation system.

2.0 CRITERIA

The Geotechnical Base Line Report prepared by S&ME dated May 19, 2015, has been provided in Attachment B for geotechnical information. In addition, soil test boring log input files have been provided electronically in gINT format.

All geotechnical testing shall comply with the requirements of the SCDOT Geotechnical Design Manual (GDM). Geotechnical design shall comply with the requirements stated below and the Special Provisions listed in Exhibit 5. Geotechnical information provided in the Appendix of the Geotechnical Base Line Report (field and lab data) as part of this RFP is intended for use in the design of this project. The Contractor shall verify that geotechnical information provided in **ATTACHMENT B** meets the requirements for a geotechnical investigation for this specific project as contained in the GDM. If the requirements of the GDM are not met, then the Contractor shall provide additional geotechnical investigation to meet the geotechnical requirements for this specific project.

2.1 Bridge

The 10 bridge structures proposed for widening on this project are to be designed in accordance with the AASHTO Standard Specifications for Highway Bridges, 17th Edition. Design criteria for minimum Factors of Safety have been modified and are provided in the following table. Geotechnical design criteria for bridge foundations are shown below.

The Contractor shall be responsible for the load testing of all foundations used on this project. All testing reports whether for driven piles or drilled shafts shall bear the legible seal, signature, and date of the testing firm's engineer registered as a Professional Engineer in the State of South Carolina. The Contractor's designer shall review and approve, in writing, all load test reports prior to submitting the reports to SCDOT for review and acceptance or comment. Comments made by SCDOT shall be reviewed and rectified by the Contractor's designer prior to the results of the load testing being used in design.

Bridge Foundations

DEEP FOUNDATIONS	Static Minimum Factor of Safety
Driven Piles with Wave Equation	3.00
Driven Piles with Dynamic Testing (PDA)	2.50
Driven Piles with Static Load Test	2.00
Drilled Shafts (Static Analysis)	3.00
Drilled Shafts with Static Load Test	2.00

2.1.1 Pile Dynamic Load Testing with Pile Driving Analyzer

If driven piles are used and a Factor of Safety of 2.5 is used for design, Pile Driving Analyzer (PDA) testing in the form of a pile index program shall be performed. In addition to the PDA testing, CAPWAP (Case Pile Wave Analysis Program) analysis shall also be performed. If prestressed concrete piles are used, regardless of the Factor of Safety used for design, PDA testing shall be performed for verification of pile driving induced stresses in the pile during installation. For PDA testing, the Contractor shall select a testing firm from those firms currently approved to provide foundation testing services on SCDOT’s Foundation Testing On-Call Contract. The Contractor shall provide a Pile Installation Plan (PIP) that shall include the pile index testing program. The pile index testing program shall at a minimum include the Bent and Pile number of each pile to be tested as well as the number of index piles to be tested. The number of index piles shall conform to the SCDOT GDM.

2.1.2 Shaft Load Testing

If drilled shafts are used and a Factor of Safety of 2.0 is used for design, a non-production drilled shaft shall be tested prior to the construction of any production drilled shafts. The number of load tests shall conform to the requirements of the latest version of the GDM. Any drilled shaft testing shall consist of either a static load test (bi-directional Osterberg Cell), a rapid load test (Statnamic), or a high-strain load test (Apple). The Contractor shall provide a Drilled Foundation Installation Plan (DFIP) that shall also include which load test procedure will be used (i.e. static, rapid, or high strain). The test shaft shall have a minimum diameter of 48 inches. The test shaft shall be located at least 25 feet from any existing bridge foundation and shall be positioned such that construction and testing operations do not adversely affect the existing bridges. In addition, the test shaft shall be located a minimum of 25 feet and a maximum of 50 feet from any future bridge drilled shaft foundation location. The location

shall avoid conflicts with any construction staging, necessary work trestle, and/or utilities.

2.2 Roadway

Any new structures required for the Project shall be designed in accordance with the SCDOT Geotechnical Design Manual, 2010 Edition. Geotechnical evaluation of existing embankments will not be required. Geotechnical evaluation of new embankments less than 3 feet in height will not be required for slope stability. Geotechnical evaluation of new embankments ~~greater than~~ 3 feet ~~and greater~~ in height will be required for slope stability **for the strength and service limit states only** and must be evaluated in accordance with the SCDOT GDM. All new embankments must be evaluated for settlement **for the service limit state only.**

The Contractor shall provide a geotechnical exploration for I-77 mainline pavements including soil test borings at 500 foot intervals as recommended by the SCDOT Pavement Design Guidelines, July 2008 to verify pavement subgrades within the proposed widening sections of the Project.

Miscellaneous overhead structure foundations such as lighting and signage shall be designed in accordance with AASHTO Standard Specifications for Structural Supports for Highway Signs, Luminaires, and Traffic Signals, effective as of the Final RFP release date.

2.3 Seismic

Geotechnical seismic design of the 10 bridge structure widenings and new or existing embankments will not be required. However, seismic design of any new structures will be required in accordance with the SCDOT Geotechnical Design Manual and SCDOT Seismic Design Specifications for Highway Bridges.

Three-Point Acceleration Design Response Spectrum (ADRS) curves have been generated for each bridge structure. For simplicity, single ADRS curves have been developed for the entire project and are supplied in this criteria for the SEE and FEE design events. The ADRS curves are provided below and shall be used in the design of all structures on this project.

A summary table of the applicable seismic coefficients is outlined below.

Design EQ	PGA	S _{DS}	S _{D1}
FEE	0.13	0.25	0.11
SEE	0.33	0.64	0.30

Based on shear wave velocity measurements at the site, the final seismic Site Class has been determined to be “C” for all bridge structures to be widened under this scope of work.

EXHIBIT 4f – GEOTECHNICAL DESIGN CRITERIA

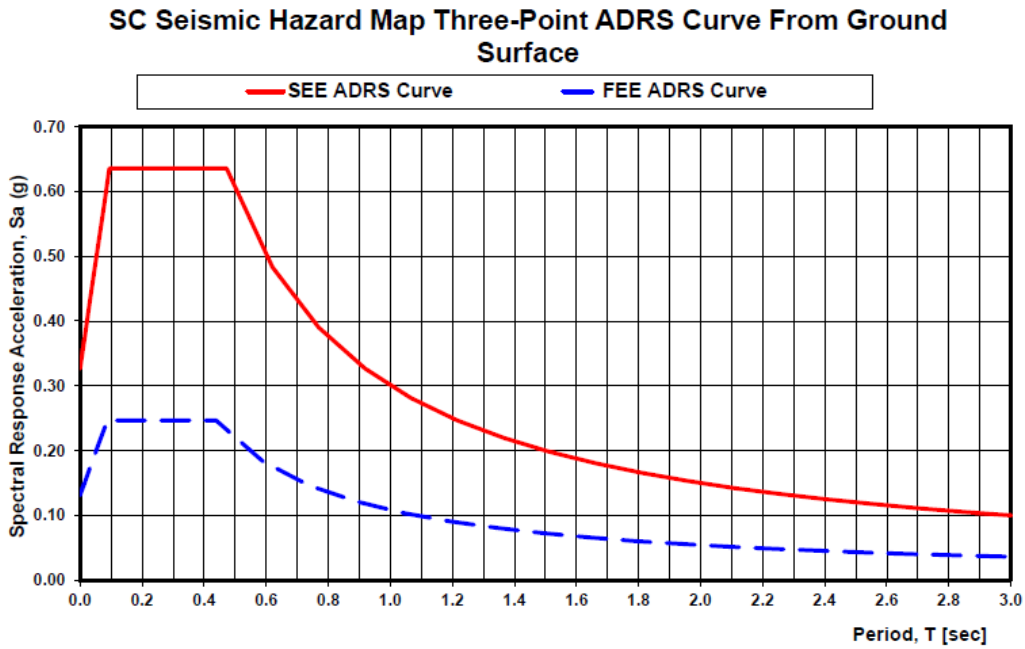

FEE ADRS Curve Three-Point Method		SEE ADRS Curve Three-Point Method	
T	S _a	T	S _a
0.00	0.13	0.00	0.33
0.01	0.15	0.02	0.38
0.03	0.17	0.03	0.43
0.04	0.19	0.05	0.48
0.06	0.21	0.06	0.53
0.07	0.23	0.08	0.58
To	0.25	To	0.64
0.12	0.25	0.13	0.64
0.15	0.25	0.16	0.64
0.18	0.25	0.19	0.64
0.20	0.25	0.22	0.64
0.23	0.25	0.25	0.64
0.26	0.25	0.28	0.64
0.29	0.25	0.31	0.64
0.32	0.25	0.35	0.64
0.35	0.25	0.38	0.64
0.38	0.25	0.41	0.64
0.41	0.25	0.44	0.64
0.44	0.25	0.47	0.64
Ts	0.25	Ts	0.64
0.50	0.18	0.62	0.48
0.74	0.15	0.77	0.39
0.89	0.12	0.92	0.33
1.04	0.10	1.07	0.28
1.19	0.09	1.22	0.25
1.34	0.08	1.36	0.22
1.49	0.07	1.51	0.20
1.64	0.07	1.66	0.18
1.79	0.06	1.81	0.17
1.95	0.06	1.96	0.15
2.10	0.05	2.11	0.14
2.25	0.05	2.26	0.13
2.40	0.05	2.41	0.12
2.55	0.04	2.55	0.12
2.70	0.04	2.70	0.11
2.85	0.04	2.85	0.11
3.00	0.04	3.00	0.10

3.0 DELIVERABLES

Geotechnical reports shall, as a minimum, contain all that is described in Chapter 21 of the SCDOT Geotechnical Design Manual and the latest design memorandums. The reports shall have design details and plan notes along with data that are consistent with that shown in the preliminary and final bridge and road plans. In addition, the Contractor's designer shall prepare the required geotechnical bridge and roadway plan sheets that clearly detail any geotechnical requirements outlined in the reports. The reports and plans shall bear the legible seal, date, and signature of the responsible engineer registered as a Professional Engineer in the State of South Carolina. Each report shall be submitted to SCDOT along with the preliminary or final bridge or roadway plan submittal. The review of the reports and plans will be performed in accordance with the submittal plan review process.

All submittals to SCDOT shall be subjected to a thorough QC review by the Contractor prior to submittal and all final submittals shall be signed and sealed by the Engineer of Record who shall be licensed and registered as a Professional Engineer in the State of South Carolina.

3.1 Preliminary Geotechnical Design Submittals

The Contractor shall submit to SCDOT:

- One (1) Hard and Electronic Copy of the Preliminary Bridge Geotechnical Engineering Report for each of the five interstate mainline bridge crossings (two bridge structures per report).
- One (1) Hard and Electronic Copy of the Preliminary Roadway Geotechnical Engineering Report to include roadway embankments, retaining walls, culverts, and/or any other roadway structure.

3.2 Final Geotechnical Design Submittals

The Contractor shall submit to SCDOT:

- One (1) Hard and Electronic Copy of the Final Bridge Geotechnical Engineering Report for each of the five interstate mainline bridge crossings (two bridge structures per report).
- One (1) Hard and Electronic Copy of the Final Roadway Geotechnical Engineering Report to include roadway embankments, retaining walls, culverts, and/or any other roadway structure.

3.3 Foundation Installation Plan Submittals

The Contractor shall prepare Drilled Foundation Installation Plans (DFIP) and/or Pile Installation Plans (PIP) in accordance with the SCDOT Standard Specifications for Highway Construction, 2007 Edition. The Contractor shall submit all foundation installation plan submittals electronically. The Contractor's designer shall review and approve all DFIP and PIP (including pile driving criteria) prior to submitting the foundation installation plans to SCDOT for review

and acceptance. SCDOT will review the foundation installation plans and provide either acceptance or comments. Comments must be resolved by the Contractor's designer prior to re-submittal to SCDOT. The Contractor is reminded that SCDOT reviews the DFIP and/or the PIP only to verify that the specifications have been addressed. After construction of the foundations is complete, the Contractor shall provide a supplement to the report containing the actual field conditions encountered and as-built foundation data and information.

3.4 Foundation Testing Submittals

The Contractor shall submit to SCDOT an electronic copy of all applicable Foundation Testing reports for all bridge and roadway structures to include but not limited to Shaft Load Test and Pile Driving Analyzer test reports.

EXHIBIT 5

SPECIAL PROVISIONS

TABLE OF CONTENTS

(1)	SECTION 101: STANDARD DRAWINGS:.....	3
(2)	SECTION 102: STANDARD DRAWING ERRATA:	3
(3)	SECTION 103: BONDS AND INSURANCE:.....	4
(4)	SECTION 103: MOBILIZATION – SUBCONTRACTOR:.....	4
(5)	SECTION 106: SOURCE OF SUPPLY AND QUALITY OF MATERIALS:	5
(6)	SECTION 106: PLANT/FABRICATOR INSPECTION:	5
(7)	SECTION 106: QUALIFIED PRODUCT LISTINGS	5
(8)	SECTION 106: SOUTH CAROLINA MINING ACT:	6
(9)	SECTION 107: PROJECT BULLETIN BOARDS:.....	6
(10)	SECTION 107: FAIR LABOR STANDARDS ACT OF 1938, AS AMENDED:	6
(11)	SECTION 107: CONTRACT PROVISION TO REQUIRE CERTIFICATION AND COMPLIANCE CONCERNING ILLEGAL ALIENS:	6
(12)	SECTION 107: DISADVANTAGED BUSINESS ENTERPRISES (DBE) GOALS AND REQUIREMENTS:	7
(13)	SECTION 107: MONITORING OF CONSTR.-RELATED EARTHBORNE VIBRATIONS:.....	9
(14)	SECTION 107: MONITORING OF EXISTING SUBSTRUCTURES:.....	12
(15)	SECTION 107: COMMUNITY AND PUBLIC RELATIONS PLAN:	12
(16)	SECTION 108: PARTNERING:	14
(17)	SECTION 109: REFERENCES TO UNIT PRICING:	14
(18)	SECTION 109: FUEL ADJUSTMENT INDEXES:	14
(19)	SECTION 202: RECLAIMING EXISTING ROADWAY:	14
(20)	SECTION 202: REMOVAL OF EXISTING GUARDRAIL:.....	15
(21)	SECTION 203: MUCK EXCAVATION:.....	15
(22)	SECTION 203: BORROW EXCAVATION:	17
(23)	SECTION 203: BORROW EXCAVATION (FOR SHOULDERS):	18
(24)	SECTION 203: BORROW PITS:	18
(25)	SECTION 204: TEMPORARY SHORING WALL:	19
(26)	SECTION 205: BRIDGE LIFT MATERIALS:	20
(27)	SECTION 205: LIGHTWEIGHT AGGREGATES:	21
(28)	SECTION 205: GEOGRID SOIL REINFORCEMENT:	23
(29)	SECTION 205: HIGH-STRENGTH GEOTEXTILE FOR EMBANKMENT REINFORCEMENT:	28
(30)	SECTION 205: MONITORING DEVICES – PIEZOMETER:.....	35
(31)	SECTION 205: SETTLEMENT PLATES:.....	36
(32)	SECTION 208: GEOTEXTILES FOR SEPARATION AND STABILIZATION:.....	41
(33)	SECTION 305: GRADED AGGREGATE BASE COURSE:.....	46
(34)	SECTION 305: MAINTENANCE STONE:	46
(35)	SECTION 308: CEMENT STABILIZED AGGREGATE BASE:	46
(36)	SECTION 401: DRESSING OF SHOULDERS:.....	46
(37)	SECTION 401: HOT MIX ASPHALT (HMA) QUALITY ASSURANCE:	46
(38)	SECTION 401: HOT-MIX ASPHALT RIDEABILITY:	46
(39)	SECTION 401: ASPHALT BINDER ADJUSTMENT INDEX:.....	46
(40)	SECTION 401: SURFACE PLANING OF ASPHALT PAVEMENT:.....	47
(41)	SECTION 401: FULL DEPTH ASPHALT PAVEMENT PATCHING:.....	49
(42)	SECTION 403: PAVING UNDER GUARDRAIL:	50
(43)	SECTION 501: ROLLER COMPACTED CONCRETE:	54
(44)	SECTION 502: FULL DEPTH CONCRETE PAVEMENT PATCHING:.....	63
(45)	DIVISION 600: TRAFFIC SIGNALS	63
(46)	DIVISION 600: FURNISH AND INSTALL DETECTOR LOOPS:	71
(47)	DIVISION 600: EVALUATION OF RETROREFLECTIVITY:.....	71
(48)	DIVISION 600: MANUAL ON UNIFORM TRAFFIC CONTROL DEVICES:	72
(49)	DIVISION 600: RULE ON WORK ZONE SAFETY AND MOBILITY:	72
(50)	SECTION 601: PENALTY FOR VIOLATING LANE CLOSURE RESTRICTIONS:	72
(51)	SECTION 601: HOLIDAY RESTRICTIONS:	72
(52)	SECTION 605: PERMANENT CONSTRUCTION SIGNS:	72
(53)	SECTION 610: WORK ZONE TRAFFIC CONTROL PROCEDURES:	72

EXHIBIT 5 – SPECIAL PROVISIONS

(54)	SECTION 653: RETROREFLECTIVE SIGN POST PANELS:	73
(55)	DIVISION 700: BEARING REPLACEMENT:	74
(56)	DIVISION 700: CONNECTIONS TO EXISTING STRUCTURAL STEEL:	74
(57)	DIVISION 700: JOINT REPLACEMENT:	75
(58)	DIVISION 700: SUBSTRUCTURE PATCHING:	75
(59)	SECTION 701: NON-CONFORMING CONCRETE:	76
(60)	SECTION 703: REINFORCING STEEL:	76
(61)	SECTION 711: PILE AND DRIVING EQUIPMENT DATA FORM:	76
(62)	SECTION 712: DRILLED SHAFT FORMS:	76
(63)	SECTION 712: BI-DIRECTIONAL STATIC LOAD TESTING OF DRILLED SHAFTS:	76
(64)	SECTION 712: RAPID LOAD TESTING OF DRILLED SHAFTS:	82
(65)	SECTION 712: HIGH STRAIN DYNAMIC LOAD TESTING OF DRILLED SHAFTS:	87
(66)	SECTION 714: SMOOTH WALL PIPE:	91
(67)	SECTION 714: PIPE END TREATMENTS (2/5/2010):	94
(68)	SECTION 714: LINE EXISTING PIPE:	97
(69)	SECTION 719: CAST IN PLACE CONCRETE PIPE COLLAR:	98
(70)	SECTION 726: PARTIAL DEPTH AND FULL DEPTH CONCRETE BRIDGE DECK REPAIR:	99
(71)	SECTION 727: CROSSHOLE SONIC LOGGING OF DRILLED SHAFT FOUNDATIONS:	99
(72)	SECTION 805: GEOTEXTILE FOR DRAINAGE FILTRATION:	100
(73)	SECTION 805: GEOCOMPOSITE WALL DRAIN:	101
(74)	SECTION 805: THREAD LOCKING GUARDRAIL HARDWARE:	104
(75)	SECTION 805: TL3 TYPE T TANGENT END TERMINALS:	104
(76)	SECTION 805: REPLACING DAMAGED GUARDRAIL:	105
(77)	SECTION 805: RESETTING GUARDRAIL:	105
(78)	SECTION 805: GUARDRAIL POSTS:	105
(79)	SECTION 806: REPAIR EXISTING CONTROL OF ACCESS FENCE:	105
(80)	SECTION 815: EROSION CONTROL MEASURES:	105
(81)	SECTION 815: SAFETY FENCE:	107
(82)	SECTION 815: ANIONIC POLYACRYLAMIDE FOR EROSION CONTROL:	108

EXHIBIT 5 – SPECIAL PROVISIONS

(1) SECTION 101: STANDARD DRAWINGS:

The Bidders are hereby advised that this project shall be constructed using the 2013 Standard Drawings with all updates effective at the time of the letting. The Standard Drawings are available for download at http://www.scdot.org/doing/sd_Disclaimer.aspx. . All drawings that are updated are labeled with their effective letting date in red.

The Standard Drawings are available to purchase through the SCDOT Engineering Publications Sales Center. The Engineering Publication Sales Center is located in Room G-19 (basement level) of the SCDOT Headquarters Building, 955 Park Street, Columbia, South Carolina.

All references in the plans, standard specifications, supplemental specifications, supplemental technical specifications or special provisions to drawings under the previous numbering system are hereby updated to the new drawing numbers. Refer to sheets 000-205-01 through 000-205-07 to find new drawing numbers when looking for references to older drawing numbers.

(2) SECTION 102: STANDARD DRAWING ERRATA:

The Bidders are hereby advised that the following note changes apply to the published Standard Drawings.

On sheet **000-205-05**, add the following information under the columns below:

OLD DRAWING NAME	NEW DRAWING NAME
720-905-01 to 720-905-05	720-901-01 to 720-993-32

On sheet **605-005-05**, replace entire text of General Note #4 with the following text:

4. The square footage of sign panels attached to 2½" x 2½" 12 gauge sign support secured to a 3" x 3" 7 gauge breakaway anchor shall not exceed 20 square feet.

On sheet **720-305-00**, delete the entire note directly above main detail:
~~If sidewalk exists, the driveway opening should...~~

On sheet **720-405-00** Detail 2 replace dimension 2'-6" maximum with:
2'-6" minimum

On sheet **720-901-01** replace note 5.04 with:

5.04 When a mid-block crossing is required, consider mid-block staggered crossing (720-955-41) to encourage eye contact between the pedestrian and the oncoming traffic. Always angle the stagger so that the pedestrian travels through the refuge facing the oncoming traffic.

On sheet **722-305-00** Detail 4 replace note "French Drain see note 21" with:
French Drain see note 4.5.

On sheet **722-305-00** table 722-305A, 4th column, change the following:
Delete (SF)

Replace text "up to 36" with "up to 3'X3' "

Replace text "larger than 36" with "larger than 3'X3' "

On sheet **804-105-00** Title Block replace text "Riprap (Bridge End)" with:
Riprap (Bridge End)

On sheet **805-325-00** detail 2 replace text "rectangular washers (FWR03) See 805-005-00" with:
"rectangular washers (FWR03) See 805-090-00"

EXHIBIT 5 – SPECIAL PROVISIONS

On sheet 805-325-00 change text of note 5 to the following:

5. For project specific requirements such as additional offset blocks, extra length posts, and post attachment details, see Project Plans. Include all costs of project specific requirements in the Guardrail Thrie-Beam Bridge Connector pay item.

On sheet 805-330-00 detail 2 replace text “rectangular washers (FWR03) See 805-005-00” with: “rectangular washers (FWR03) See 805-090-00”

On sheet 805-330-00 change text of note 4 to the following:

4. For project specific requirements such as additional offset blocks, extra length posts, and post attachment details, see Project Plans. Include all costs of project specific requirements in the Guardrail Thrie-Beam Bridge Connector pay item.

On sheet 805-510-00 detail 3 replace guardrail base plate note with the following:

See standard drawings 805-655-xx for guardrail base plate options.

On sheet 805-655-M1 replace note 30.4 with the following:

30.4 Install adhesive anchors to a depth sufficient to develop a minimum factored (reduced) ultimate tensile capacity of 21 kips per anchor bolt. Increase minimum embedment shown in detail 4 as required by adhesive manufacturer’s recommendations for the existing material properties, anchor bolt pattern, edge conditions, and any other design reduction.

On sheet 805-811-01 Type 11A barrier wall reinforcement add the following note:

Provide reinforcement equal to the stem reinforcement and bending details shown for the Type 11B concrete barrier (drawing 805-811-02).

On sheet 815-002-00 Type B, D1, & D2 Inlet Structure Filters, revise as follows:

Replace all references of #5 stone with #5 or #57 stone.

On sheet 815-305-00 Sediment Control Structure and Basin, revise as follows:

Replace all references of #5 stone with #5 or #57 stone.

On sheet 815-405-00 Sediment Dams, revise as follows:

Replace all references of #5 stone with #5 or #57 stone.

Payment for either #5 or #57 stone will be made under the pay item for **Aggregate No. 5 for Erosion Control (6 “ Uniform)**

(3) SECTION 103: BONDS AND INSURANCE:

Bonds and Insurance consists of all Bonds and Insurance required of the contractor. A maximum allowable amount of 2.0% of the total contract amount will be paid on the first pay estimate after work begins. If there is a remaining amount of the lump sum price for Bonds and Insurance after payments are made according to the limit above, then the remaining amount will be paid on the final estimate.

If special insurance is required by the contract provisions, such as railroad or coastal insurance, no maximum limit will apply to this bid item.

Item No.	Pay Item	Unit
1032010	BONDS AND INSURANCE	LS

(4) SECTION 103: MOBILIZATION – SUBCONTRACTOR:

Mobilization – Subcontractor consists of the preparatory operations for subcontractors including: moving personnel and equipment to the project site; paying bond and insurance premiums; establishing offices, buildings, and other facilities necessary for work on the project; and all other preparatory work or costs incurred before beginning work on the project.

EXHIBIT 5 – SPECIAL PROVISIONS

Mobilization - Subcontractor is paid at the lump sum price bid, which price and payment is full compensation for organizing and moving all subcontractor forces, supplies, equipment and incidentals to the project site, regardless of the number of times such moves are made. The price and payment also includes costs for demobilization.

When the item Mobilization – Subcontractor is included in the bid items, payment will be made on the first four construction estimates. Each payment is for 25% of the lump sum price for Mobilization - Subcontractor, subject to the maximum total limit of 5.0% of the total contract amount.

If there is a remaining amount of the lump sum price for Mobilization after payments are made according to the limit above, then the remaining amount is paid after all work on the project has been completed and accepted.

Partial payment for this item in no way acts to preclude or limit any of the provisions of partial payments otherwise provided for by the Contract or these specifications.

Payment for this item includes all direct and indirect costs and expenses required to complete the work.

Pay items under this section include the following:

Item No.	Pay Item	Unit
1031100	MOBILIZATION – SUBCONTRACTOR	LS

(5) SECTION 106: SOURCE OF SUPPLY AND QUALITY OF MATERIALS:

Delete Paragraph 3 of Subsection 106.1 and replace it with the following:

“When materials, components, or elements that are not specifically covered in the Standard Specifications, Supplemental Specifications, Supplemental Technical Specifications, or Project Special Provisions are proposed to be incorporated into the work, submit to the RCE a specification covering the proposed material, component, or element for review and acceptance prior to incorporating it into the work. Ensure that such materials, components, or elements meet the requirements of the AASHTO specifications that were effective as of the date of the Final RFP. If the materials, components, or elements are not covered in the AASHTO specifications, ensure that they meet the requirements of the ASTM specifications that were effective as of the date of the Final RFP. Submission of a specification for a material, component, or element not covered in the Standard Specifications, Supplemental Specifications, Supplemental Technical Specifications, or Project Special Provisions does not guarantee approval for use on the Project.”

(6) SECTION 106: PLANT/FABRICATOR INSPECTION:

Subsection 106.4, **Plant Inspection**, of the Standard Specifications shall be amended with the following:

Change the subsection title to **Plant/Fabricator Inspection** and add the following sentence after the first sentence:

“Provide 14 calendar days written notice to the Materials and Research Engineer prior to beginning fabrication work for Department projects.”

(7) SECTION 106: QUALIFIED PRODUCT LISTINGS

All references to “Approval Sheet” or “Approval Policy” are to be replaced with “Qualified Products Listings (QPL)” and “Qualified Products Policies (QPP)” respectively. This change includes all references in the SCDOT Standard Drawings, SCDOT Standard Specifications, SCDOT Supplemental Specifications, SCDOT Special Provisions, SCDOT Supplemental Technical

EXHIBIT 5 – SPECIAL PROVISIONS

Specifications, SCDOT Internet and Intranet websites, and all other documents produced by SCDOT.

(8) SECTION 106: SOUTH CAROLINA MINING ACT:

This Supplemental Specification is hereby modified as follows:

Paragraph 9 is hereby deleted and replaced with the following:

The deputy secretary for engineering, or his duly appointed representative, will make a final inspection of the reclaimed area and keep a permanent record of his approval thereof. A map or sketch providing the location and approximate acreage of each pit used on the project will be provided to the resident construction engineer for inclusion in the final plans.

The last paragraph is hereby deleted and replaced with the following:

The contractor shall comply with the provisions of the plan that are applicable to the project as determined by the engineer. Seeding or other work necessary to comply with the plan on pits furnished by the contractor shall be at the expense of the contractor. Seeding shall be in accordance with SC-M-810 (latest version) which can be found at http://www.scdot.org/doing/road_SupTechSpec.aspx.

(9) SECTION 107: PROJECT BULLETIN BOARDS:

In accordance with the Required Contract Provisions Federal-Aid Construction Contracts Section II, Item 3, Part d, add the following:

Single Location Projects – On projects in which work is performed at a single location (such as bridge replacement projects, two-lane to five-lane widening projects, etc.), mount the project bulletin board in a permanent location within the project limits so that it is visible and accessible at all times.

Multiple Location Projects – On projects in which work is being performed or has the capability of being performed at multiple locations (such as resurfacing projects, pavement marking projects, etc.), display a portable bulletin board with at least one of the prime contractor’s work crews. If the prime contractor is not performing work, display the portable bulletin board with at least one of the subcontractor’s work crews. Display the portable bulletin board in a location and a manner that is acceptable to the RCE. Notify the RCE and all subcontractors as to the location of the portable bulletin board. On resurfacing projects, mount an additional project bulletin board in a permanent location at the asphalt plant supplying asphalt mix to the project so that it is visible and accessible at all times.

(10) SECTION 107: FAIR LABOR STANDARDS ACT OF 1938, AS AMENDED:

Attention is directed to this Federal Legislation, which has been enacted into law. The contractor will be responsible for carrying out all of the provisions of this legislation, which may affect this contract.

(11) SECTION 107: CONTRACT PROVISION TO REQUIRE CERTIFICATION AND COMPLIANCE CONCERNING ILLEGAL ALIENS:

By submission of this bid, the bidder as the prime contractor does hereby agree:

- a. to certify its compliance with the requirements of Chapter 14 of Title 8 of the S.C. Code of Laws regarding Unauthorized Aliens and Public Employment;
- b. to provide SCDOT with any documents required to establish such compliance upon request; and
- c. to register and participate and require agreement from subcontractors and sub-subcontractors to register and participate in the federal work authorization program to verify the employment authorization of all new employees, or to employ only workers who supply the documents required pursuant to S.C.Code 8-14-20(B)(2).

(12) SECTION 107: DISADVANTAGED BUSINESS ENTERPRISES (DBE) GOALS AND REQUIREMENTS:**1. GENERAL**

For Design Build Projects, PROPOSER shall comply with the Disadvantaged Business Enterprises (DBE) Supplemental Specification, dated May 2, 2014, except as specifically modified pursuant to this special provision. This special provision modifies the timing and steps for which the PROPOSER is to obtain DBE committals for a design build project.

2. DBE PROGRAM RELATED CERTIFICATIONS

By submitting a proposal and by entering into any contract on the basis of that proposal, the PROPOSER certifies to each of the following DBE Program-related conditions and assurances:

- a. That the PROPOSER agrees to comply with the project construction and administration obligations of the USDOT DBE Program, 49 CFR Part 26 as amended, and the DBE Supplemental Specifications setting forth the SCDOT's DBE Program requirements.
- b. PROPOSER shall comply fully with the DBE Program requirements in the execution and performance of the Contract. PROPOSER acknowledges that failure to comply may result in any one or more of the sanctions listed in the SCDOT's DBE Supplemental Specification.
- c. To ensure that DBE firms have been given full and fair opportunity to participate in the performance of the contract, PROPOSER certifies that all reasonable steps were, and will be, taken to ensure that DBE firms had, and will have, an opportunity to compete for and perform work on the contract. The PROPOSER further certifies that the PROPOSER shall not discriminate on the basis of race, color, age, national origin, or sex in the performance of the contract or in the award of any subcontract. Any agreement between a PROPOSER and a DBE whereby the DBE promises not to provide quotations for performance of work to other PROPOSERS is prohibited.
- d. PROPOSER shall make good faith efforts to obtain DBE participation in the proposed contract at or above the goal. The PROPOSER, by submitting its proposal, certifies the DBE participation information that will be submitted within the required time as specified herein is true, correct, and complete, and that the information to be provided includes the names of all DBE firms that will participate in the contract, the specific item(s) that each listed DBE firm will perform, and the dollar amounts of the participation of each listed DBE.
- e. By submitting its proposal, the PROPOSER certifies that good faith efforts will be made on work that it proposes to subcontract; and that it will seek out and consider DBE firms as potential subcontractors and sub-consultants. The PROPOSER shall, as a continuing obligation, contact DBE firms to solicit their interest, capability, and prices in sufficient time to allow them to respond effectively, and shall retain on file proper documentation to substantiate its good faith efforts.
- f. PROPOSER shall comply fully with all contractual and legal requirements of the USDOT DBE Program and SCDOT DBE Program, and shall cause each DBE firm participating in the Contract to fully perform the designated work items with the DBE firm's own forces and equipment under the DBE firm's direct supervision, control, and management. Where a contract exists and where the PROPOSER, DBE firm, or any other firm retained by the PROPOSER has failed to comply with federal or SCDOT DBE Program requirements, SCDOT has the authority and discretion to determine the extent to which the DBE contract regulations have not been met, and will assess against the PROPOSER any remedies available at law or provided in the contract.
- g. If a bond surety assumes the completion of work, if for any reason the SCDOT has terminated the PROPOSER, the surety shall be obligated to meet the same DBE contract terms and requirements as were required of the original PROPOSER in accordance with the requirements of this contract.

3. DBE PROGRAM COMPLIANCE PROCEDURES

a. DBE Utilization Plan

- (1) Within thirty (30) calendar days from the effective date of the Agreement, the PROPOSER shall submit to the SCDOT a DBE Utilization Plan for review and approval. This plan shall include the following information:
 - i. The various work elements the PROPOSER anticipates subcontracting to DBE firms in order to meet the established contract goal;
 - ii. The expected dollar amount and contract percentages of each work element to be applied towards meeting the contract goal; and
 - iii. Anticipated timeframes for which PROPOSER expects DBE subcontracts to be executed for each of the work elements identified.
- (2) The SCDOT will not accept or review any design submittals from the PROPOSER nor make any progress payments until the DBE Utilization Plan is approved by SCDOT. However, failure to promptly submit the DBE Utilization Plan will not delay the SCDOT's issuance of the Notice to Proceed thereby commencing Contract Time.
- (3) As the Project proceeds through the design phase, the PROPOSER may submit revisions to the approved DBE Utilization Plan, if necessary, for the SCDOT's consideration and approval. Reasons for the revisions shall be documented by the PROPOSER and included in the revision request.
- (4) In the DBE Utilization Plan submittal, CONTRACTOR shall designate and make known to the SCDOT a DBE liaison officer who is assigned the responsibility of administering and promoting an active and inclusive DBE program as required by 49 CFR Part 26, the SCDOT's DBE Supplemental Specifications, and this Special Provision.
- (5) After approval of the DBE Utilization Plan, PROPOSER may begin submitting DBE Committal Sheets for review and acceptance at the monthly Progress Meetings.

b. Establishing DBE Committals

- (1) The PROPOSER shall aggressively implement the approved DBE Utilization Plan by submitting DBE Committal Sheets listing specific DBE firms to carry out the identified work elements. **The use of DBE firms and the information to be provided on the DBE Committal Sheet shall be as instructed in Part A of the SCDOT's DBE Supplemental Specification (Exhibit 7).**
- (2) The PROPOSER shall obtain the SCDOT's approval of all subcontracts as set forth in the SCDOT DBE Supplemental Specification.
- (3) PROPOSER shall not unilaterally terminate, substitute for, or replace any DBE firm listed on the Committal Sheet in whole or in part with another DBE, any non-DBE firm, or with the PROPOSER's own forces without the prior written consent of SCDOT as set forth in the SCDOT DBE Supplemental Specification.
- (4) The PROPOSER's Final DBE Committal Sheet, signed quotes, and all DBE executed subcontracts are to be submitted to the SCDOT within **180 90** calendar days from the "Notice To Proceed." If the PROPOSER fails to meet the **180 90** calendar day deadline, SCDOT shall withhold progress payments until the Final DBE Committal Sheet is submitted.
- (5) If the Final DBE Committal Sheet falls short of the DBE contract goal, the PROPOSER shall submit good faith efforts documentation in accordance with Part A of the DBE Supplemental Specification. This information is due within three (3) business days following the due date of the Final DBE Committal Sheet. If upon review of the Final DBE Committal Sheet, good faith efforts documentation and, if necessary, the findings of the Reconsideration Panel, the PROPOSER fails to meet the contract DBE goal or demonstrate good faith, the SCDOT will withholding monthly progress payments until compliance with DBE contract goal or PROPOSER's good faith efforts have been accepted by SCDOT.

- c. Progress Review Meetings / Monthly Updates
- (1) Implementation of the PROPOSER's DBE Utilization Plan shall be a discussion point during each progress review meeting (as required in the Agreement) until such time as the SCDOT deems it a closed issue. The PROPOSER's DBE liaison officer shall attend all progress review meetings until such time the issue is closed. At each progress review meeting, the DBE liaison officer shall provide a summary of the PROPOSER's progress towards implementing the DBE Utilization Plan as well as provide an updated DBE Committal sheet.
 - (2) The PROPOSER shall provide the SCDOT monthly updates of its progress in accomplishing the DBE Utilization Plan. Monthly updates must include a copy of the latest committal sheet, signed quotes and copies of executed DBE subcontracts. The SCDOT's approval date of the DBE Utilization Plan will establish the date for which monthly updates are required of the PROPOSER.
 - (3) The SCDOT, at its discretion, may withhold progress payments if the PROPOSER fails to submit monthly updates or any other submittal requirement on time or if the SCDOT believes the efforts of the PROPOSER in implementing the DBE Utilization Plan are insufficient.
- d. PROPOSER's Obligation Post DBE Committal
- (1) **Once a firm is listed on the DBE Committal sheet, the PROPOSER shall administer the subcontract with the firm in accordance with the instructions provided in Part B of the SCDOT DBE Supplemental Specification.**
 - (2) It is the PROPOSER's responsibility to comply with all elements of the SCDOT's DBE Program and to continuously pursue DBE participation as the project progresses. If the PROPOSER's Final DBE Committal Sheet and good faith efforts fall short of meeting the project goal and/or payments to committed DBE firms were less than the committed amounts, SCDOT may impose one of the sanction set forth under Part B of the SCDOT DBE Supplemental Specifications.
 - (3) PROPOSER, for itself, for its design build team, and for its subcontractors and suppliers, whether certified DBE firm or not, commits to complying fully with all federal and state DBE provisions and agrees to assume these contractual obligations and to bind the design build team contractually to the same at the PROPOSER's expense.

(13) SECTION 107: MONITORING OF CONSTR.-RELATED EARTHBORNE VIBRATIONS:

July 8, 2015

1.0 DESCRIPTION:

The project construction will generate vibrations that will travel through the earth, which will subsequently be received or "sensed" by nearby structures and inhabitants. Specific procedures that will generate earthborne vibrations during bridge and roadway construction include (but are not limited to) the installation of piles, earthquake drains, shoring walls, general foundation construction, and vibratory compaction of unclassified or borrow excavation. To mitigate the risk of vibration-related damage to nearby structures, this specification outlines the Contractor's responsibility for performing a program of pre-construction condition assessment and vibration monitoring during construction.

This specification is based, in part, on AASHTO R 8-96 (2004) *Standard Recommended Practice for Evaluation of Transportation-Related Earthborne Vibrations*. As discussed in AASHTO R 8-96 (2004), humans respond to a much broader range of vibration frequencies and intensities than structures. Intrusive vibration levels can annoy humans at much lower intensities than levels considered critical for structures. Thus, occupants of adjacent properties may perceive that the construction-induced vibrations may present risk to their structures. The recommended safe vibration limits are intended to mitigate the risk of structure damage, and more specifically, reduce the development of "threshold cracks" or

cosmetic cracking. Such cracks may appear at lower vibration levels than the level at which architectural or minor structural damage would be expected to occur.

2.0 PRE-CONSTRUCTION CONDITION ASSESSMENT:

The Contractor shall retain a geotechnical engineering firm to perform a pre-construction condition assessment to document the conditions of nearby buildings and other sensitive nearby structures prior to the beginning of construction. The assessment shall be performed on all properties adjacent to the project site and any other properties as directed by the Engineer. The assessment shall include any structures within 300 feet of any vibration inducing construction activity. The assessment should include video and photographic documentation of all exteriors and interiors, and installation of crack monitors on cracks that might propagate due to construction vibrations. All documentation of existing building conditions and information concerning the type and location of crack monitors shall be presented to the Engineer in a report prior to construction.

3.0 CRACK MONITORING DURING CONSTRUCTION:

During all construction, the Contractor shall perform periodic readings of the crack monitors that were installed during the pre-construction condition assessment. All readings shall be provided to the Engineer within 48 hours of taking the reading. Provided that the crack readings confirm that vibrations are not contributing to increasing the crack width, the crack monitors may be read once per week. More frequent readings may be directed by the Engineer during activities that are expected to have greater earthborne vibrations (e.g., pile driving). If the crack readings suggest that vibrations from the project site are contributing to crack width, then the Contractor shall immediately notify the Engineer and review those activities that are generating the earthborne vibrations. The Contractor and his or her geotechnical firm shall then submit a detailed plan for repair, perform the repair at no cost to the Department and develop and submit for review a revised construction plan to address the vibration problems and minimize further damage and complaints.

4.0 VIBRATION MONITORING DURING CONSTRUCTION:

- A. Procedure - The Contractor shall monitor vibrations at no less than four locations **at each specific site of construction activity** along the perimeter of the project during all foundation and embankment construction activities. The locations shall be selected by the Contractor based on the location of the construction activities and their relative position to nearby offsite structures. Prior to construction, a plan of the monitoring locations shall be submitted to the Engineer for acceptance. The locations of the vibration monitors shall be adjusted during construction with acceptance by the Engineer. The vibration monitors shall be established at the site so that background vibrations may be determined prior to beginning foundation or embankment construction. The sensitivity range of the seismograph shall be selected so that the recording is initiated below the maximum allowable particle velocity shown in Figure 1 and extends above the highest expected intensity. Specific activities of the vibration source shall be indexed in time to allow correlation with the arrivals on the vibration
- B. Project Vibration Criteria - The maximum allowable particle velocity is shown in Figure 1. If the data from the monitors indicate that vibrations are exceeding the established criteria, then the Contractor shall immediately notify the Engineer and suspend those activities which are generating the earthborne vibrations, until the Contractor and his or her geotechnical firm have developed a revised construction plan to resolve the problem. The problem shall be resolved at no additional cost to the Department.
- C. Instrumentation – The vibration monitors shall consist of digital seismographs that display the particle velocities and associated frequencies plotted against the criteria for this project (i.e., Figure 1). Each seismograph shall contain geophones with response capability in three mutually perpendicular axes or components: one vertical and two horizontal (radial and transverse). The frequency response of the geophones shall be linear from at least 4 Hz to more than 200 Hz. The sensitivity shall range from less than

EXHIBIT 5 – SPECIAL PROVISIONS

0.02 in/sec to more than 5.0 in/sec. The BlastMate III by InstanTel is one type of seismograph that is suitable for this project.

- D. Calibration and Instrument Use - The Contractor shall field calibrate the vibration monitors before the start of each recording period. The transducer shall be positioned with the longitudinal axis toward the vibration source. Transducers must be adequately coupled with the ground. Operation of all vibration monitors shall be in accordance with the instrument manufacturer's instructions and recommendations. Vibration records shall be collected in waveform plot or strip chart plot. The peak vector sum of the particle velocity in longitudinal, transverse, and vertical planes shall be shown along with the respective dominant or principle frequencies. The highest recorded particle velocity (i.e., the vector sum of the three orthogonal directions), when indexed to a particle vibration event, shall be reported as the peak particle velocity. The recorded peak particle velocity shall be compared to criteria appropriate for the subject of concern.
- E. Complaints - In the event of a complaint, the Contractor shall immediately contact the Engineer and review those construction activities that are inducing vibrations into the earth. The Contractor shall prepare a report documenting all relevant data such as the time and date presented in the complaint, a description of the construction activities during the subject time/date, data from the monitoring instruments for the subject time/date, complaint information and a description (including photographs, if possible) of the alleged damage. The Contractor and his or her geotechnical firm shall then submit a detailed plan for repair, perform the repair at no cost to the Department and develop and submit for review a revised construction plan to address the vibration problems and minimize further damage and complaints.

5.0 METHOD OF MEASUREMENT:

In addition to the pre-construction condition assessment report, the Contractor shall also provide monthly reports containing the results of the crack monitors and vibration monitors during those activities that generate earthborne vibrations, including (but not limited to) ground improvement and foundation construction. The reports shall document that the Contractor is providing the work described by this specification.

6.0 BASIS OF PAYMENT:

Payment shall be made in proportion with the percent of the project that is complete. Final payment of the remaining lump sum balance shall be made when vibration monitoring is complete as approved by the Engineer. Payments shall be made under:

Item No.	Pay Item	Pay Unit
1075001	MONITORING OF CONSTRUCTION-RELATED EARTHBORNE VIBRATIONS	Lump Sum

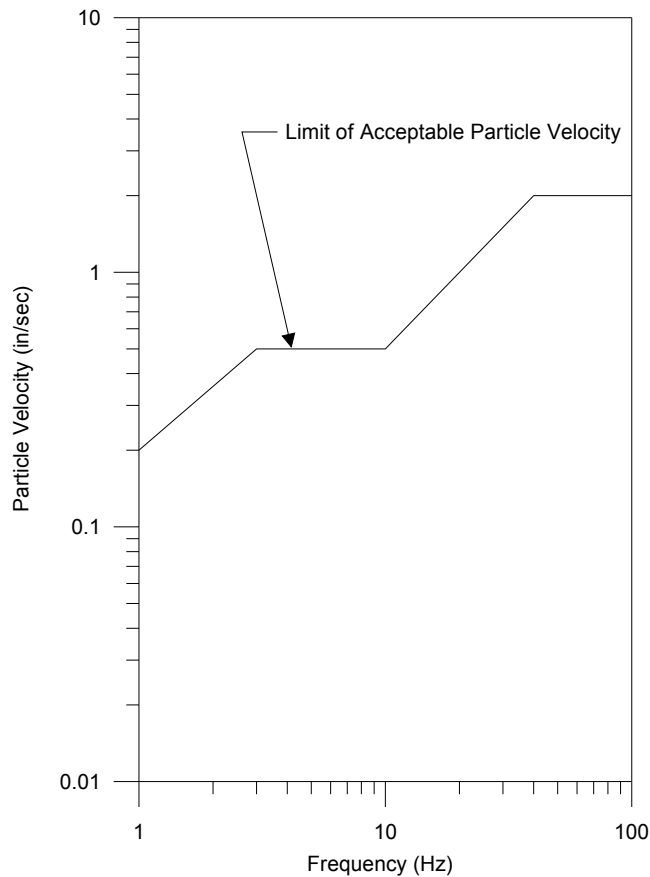

Figure 1 - Vibration Criteria (adapted from AASHTO R8-96)

(14) SECTION 107: MONITORING OF EXISTING SUBSTRUCTURES:

Bents 2 and 5 of the NBL and SBL Overpasses over I-20 & I-20 Ramp are supported by shallow foundations. The Contractor shall monitor these four bent locations for settlement during construction of the new substructures for the widened bridges. The Contractor shall prepare a plan for existing bridge settlement monitoring and submit the plan to SCDOT for concurrence. The monitoring plan shall include data points and collection of elevation data at each existing interior bent column of Bents 2 and 5. During construction activities at Bents 2 and 5, adjacent column data points shall be continuously monitored by the Contractor.

At any time, if settlement occurs simultaneously with construction activities, the Contractor shall immediately stop those activities. The Contractor shall then submit a detailed plan for any repair that is needed, perform the repairs at no cost to SCDOT, and develop and submit for review a revised construction plan to address the problem and minimize further damage.

(15) SECTION 107: COMMUNITY AND PUBLIC RELATIONS PLAN:

SCDOT will take the lead role on this project and be responsible for a portion of the public information efforts. Unless noted otherwise elsewhere in this RFP, the SCDOT responsibilities include:

Developing and maintaining the project website

Soliciting and administering advertisements and media announcements, as deemed necessary

The CONTRACTOR shall coordinate with the Department to promote public awareness for this project. The amount of public involvement required for this project is directly based on the

EXHIBIT 5 – SPECIAL PROVISIONS

CONTRACTOR's Transportation Management Plan and construction details. The Design- Build Team's responsibilities shall include:

- Providing details surrounding the impacts to the public
- Providing advance notice to the Department of upcoming project impacts
- Assisting the Department in the development of the target audience list
- Attending and/or speaking at public meetings
- Hand delivery of time sensitive informational materials
- Preparing advertisements and media announcements
- Preparing and forwarding direct mailers, flyers, and other promotional materials as necessary
- If required, organizing public meetings, including venue selection, reservation and fee

The CONTRACTOR shall hold an initial project coordination meeting with SCDOT at least one month prior to start of construction to discuss project impacts to the public. This information will be used by the CONTRACTOR to create a Public Information Plan.

The CONTRACTOR shall inform the Department at least twenty-one (21) calendar days in advance of any construction activity that will have significant impact on the public, including, but not limited to, the start of construction, major traffic shifts, road closures, ramp closures, detours, night work and project completion.

The CONTRACTOR will develop, with the assistance of SCDOT, the specific list of target audiences for this project. The following groups are identified as typical target audiences to receive informational materials:

- State Senator(s) and Representative(s)
- Chairman of the County Council
- County Administrator/Manager
- County Planner
- City Mayor (as appropriate)
- City Manager (as appropriate)
- Transportation services
- Emergency services
- Neighborhood groups and private homes
- Industry and businesses
- Chamber(s) of Commerce
- Individual schools effected by the project
- Public School District(s) and Transportation Office(s)
- Post Office
- Any other organization as deemed necessary by the Department

The minimum public information requirements solely associated with the Transportation Management Plans shall include, but not be limited to the following:

Public Meetings - If Beginning of Construction meeting for area businesses and residents is held, attending and I or speaking at this event.

Distribution of Informational Materials - For beginning of construction and for all road closures with detour routes, the CONTRACTOR shall be responsible for delivering time sensitive informational material provided by the SCDOT directly to portions of the target audience. If the CONTRACTOR informs the Department of the aforementioned activities less than twenty-one (21) calendar days in advance, the CONTRACTOR shall hand deliver the informational materials to the impacted target audiences.

The Department will be responsible for establishing, creating, maintaining and updating the project website for this project. However, throughout the project duration, the CONTRACTOR shall coordinate with the RCE to ensure the accuracy of the aforementioned project website. At a minimum, the CONTRACTOR shall designate a contact for public information inquiries and coordination. Throughout construction, at a minimum, this contact shall provide bi-weekly updates to the RCE, including, but not limited to, traffic control phasing, graphic illustrations, project pictures, etc.

The CONTRACTOR shall include in their Total Cost to Complete, all costs associated with their involvement in the Community and Public Relations Plan.

(16) SECTION 108: PARTNERING:

(A) Covenant of Good Faith and Fair Dealing

This Contract imposes an obligation of good faith and fair dealing in its performance and enforcement. The CONTRACTOR and Department, with a positive commitment to honesty and integrity, agree to the following mutual duties:

- (1) Each will function within the laws and statutes applicable to their duties and responsibilities.
- (2) Each will avoid hindering the other's performance.
- (3) Each will proceed to fulfill its obligations diligently.
- (4) Each will cooperate in the common endeavor of the Contract.

(B) Partnering

The Department encourages the foundation of cohesive partnering with the CONTRACTOR and its principle subcontractors and suppliers. This partnering is not a legal partnership as defined by South Carolina law. Partnering will be structured to draw on the strengths of each organization to identify and achieve reciprocal goals. The objectives are effective and efficient contract performance and completion within budget, on schedule, and in accordance with the Contract.

The establishment of a partnering charter will not change the legal relationship of the parties to the contract nor relieve either party from any of the terms of the Contract. Any cost associated with effectuating partnering will be agreed to by the Department and the CONTRACTOR and will be shared equally between them.

(17) SECTION 109: REFERENCES TO UNIT PRICING:

Any references in the contract documents to unit price, measurement, and payment, are typical references for design-bid-build contracts and are not applicable to the extent they effect payment on Design-Build contracts. The Design-Build contractor's schedule of values shall provide sufficient detail to compare work progress to the contractor's schedule and determine appropriate periodic payments.

(18) SECTION 109: FUEL ADJUSTMENT INDEXES:

No fuel adjustment will be made on this Project.

(19) SECTION 202: RECLAIMING EXISTING ROADWAY:

Description:

This work consists of the restoration of paved areas. These areas are typically shown as hatched areas on the plans when outside the construction limits.

Materials:

None

Construction Requirements:

- 1.) Asphalt Pavement with Earth Base: Remove and dispose of areas of pavement shown as hatched areas on the plans. Grade the area to properly drain. Seed the area in accordance with Section 810.
- 2.) Asphalt Pavement with Stone Base: Remove and dispose of areas of pavement and base shown as hatched areas on the plans. Grade the area to properly drain. Seed the area in accordance with Section 810.
- 3.) Earth roadway or Bituminous Surfacing with Earth Base: Scarify existing areas of roadway. Grade the area to properly drain. Seed the area in accordance with Section 810.
- 4.) Bituminous Surfacing with Stone Base: Remove and dispose of areas of pavement and base shown as hatched areas on the plans. Grade the area to properly drain. Seed the area in accordance with Section 810.

Suitable materials may be used for embankment construction on the project. In the event that removed materials are used for embankment construction a corresponding deduction in Unclassified Excavation will be made by the Resident Construction Engineer.

Measurement:

Removed asphalt pavement greater than 2 inches in depth will be measured by the square yard. Removed bituminous surfacing with stone base will be measured by the cubic yard. Removed stone base will be measured by the cubic yard. Scarified areas will not be measured for payment.

Payment:

Removed asphalt pavement which is greater than 2 inches in depth will be paid at the unit price bid for Removal and Disposal of Existing Asphalt Pavement. Removed bituminous surfacing with stone base will be paid for at the unit price bid for Unclassified Excavation. Removed stone base will be paid for at the unit bid price for Unclassified Excavation. No payment will be made for scarifying earth roadway or bituminous surfacing with earth base. No separate or additional payment will be made for grading necessary to obtain proper drainage.

(20) SECTION 202: REMOVAL OF EXISTING GUARDRAIL:
Section 202.4.4.3 applies on this project.

(21) SECTION 203: MUCK EXCAVATION:

September 19, 2011

Section 203.2.1.3 is amended as follows:

Any areas identified on the plans and any additional areas defined by the RCE that are discovered to deflect or settle may require corrective action by the Contractor. This may include undercutting, placing granular aggregate, placing stone aggregate that is separated from other fine aggregate materials by a geotextile for separation of sub-grade and sub-base, and/or additional compacting to the approval of the Engineer.

In areas that require mucking or undercutting, borrow excavation soil may be placed as a bridge lift as long as the grade on which the material is being placed is at least 2 feet above ground water level. In the event that groundwater does not allow backfilling with a borrow excavation soil, a stone or granular material shall be used as the bridge lift material. This stone or granular material shall be in accordance with the Bridge Lift Materials Special Provision. Stone bridge lift

EXHIBIT 5 – SPECIAL PROVISIONS

materials shall have a thickness of 2 feet and shall extend a minimum of 6 inches above the ground/surface water level. Granular lift materials shall also have a thickness of 2 feet, but shall extend a minimum of 2 feet above ground/surface water level. Individual granular bridge lifts shall not exceed a 2-foot thickness without some type of limited compactive/tamping effort. The depth at which mucking or undercutting shall take place is dependent upon encountering a suitable bearing material within the excavation or a predetermined elevation or depth. In most cases, undercutting shall not exceed 3 to 5 feet in depth, but the final mucking or undercutting thickness shall be based on the decision of the RCE, unless otherwise specified in the project plans and/or specifications. If a suitable bearing soil is not encountered within this depth range or unless otherwise specified in the plans and/or specifications, a P1 biaxial geogrid with an aperture size of less than or equal to 1 inch shall be placed beneath the stone or granular bridge lift material. The geogrid shall be placed in the bottom of the excavation and up the excavation side slopes. If additional compacted borrow excavation soil is needed to reach grade, a geotextile for separation of sub-grade and sub-base shall be placed between any stone bridge lift material and the overlying compacted soil. A bridge lift consisting of borrow excavation soil or granular bridge lift material should not be placed within 3 feet of the base of the pavement section. Only compacted borrow excavation soil or stone bridge lift material shall be placed within this zone. The biaxial geogrid shall be in accordance with the Special Provision provided in the project documents.

The quantities associated with mucking and undercutting, i.e. mucking, stone and granular bridge lift materials, geogrid, and geotextile for separation of sub-grade and sub-base, are for bid estimation purposes only. These bid items shall not be purchased and stockpiled on site without written approval from the RCE unless specific areas and details are defined in the plans.

EXHIBIT 5 – SPECIAL PROVISIONS

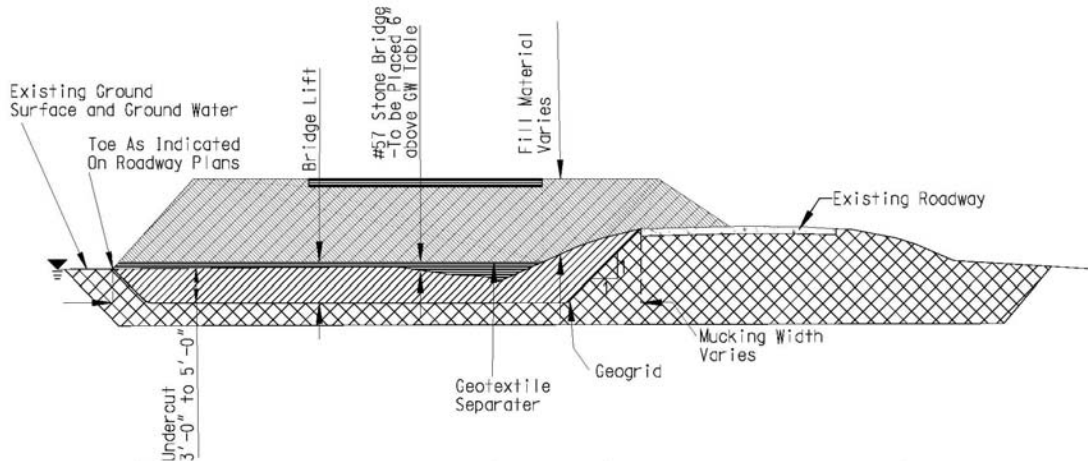

UNDERCUT, GEOGRID, AND STONE BRIDGE LIFT

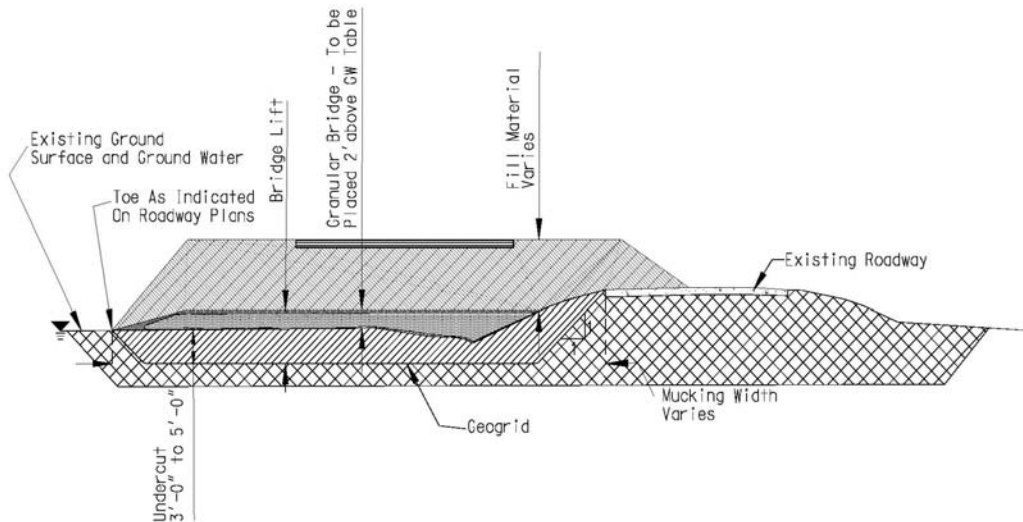

UNDERCUT, GEOGRID, AND GRANULAR BRIDGE LIFT

(22) SECTION 203: BORROW EXCAVATION:

March 6, 2013

Section 203.2.1.8 of the Standard Specifications is amended as follows:

Ensure that all borrow material placed on embankments meet or exceed the requirements for total and effective internal friction angle, cohesion, and total moist unit weight as specified by the geotechnical design engineer of record. These requirements shall be determined by the following tests:

- Internal friction angle determined from either direct shear (AASHTO T236) or triaxial (AASHTO T297) testing on remolded specimens performed by the Contractor.
- Cohesion determined by triaxial (AASHTO T297) testing on remolded specimens performed by the Contractor.
- Total moist unit weight determined by standard proctor test (AASHTO T99) on remolded specimens performed by the Contractor.

EXHIBIT 5 – SPECIAL PROVISIONS

Remold all samples to 95 percent of the maximum dry density as determined by the Standard Proctor test (AASHTO T99) and test at normal/consolidation stresses specified by the geotechnical design engineer of record. Conduct shear strength and soil classification testing (AASHTO M145) at the initial selection of the borrow pit, any subsequent changes in borrow pits, and for every 50,000 cubic yards of materials placed. This testing is in addition to the normal embankment and borrow sampling and testing requirements for classification and compaction in accordance with Section 205 of the SCDOT Standard Specifications for Highway Construction that are used for daily acceptance.

Perform additional shear strength testing and/or soil classification testing at no additional cost to the Department when the Department deems that the materials being placed appear to be different from those originally tested. Submit all test results to the RCE for approval prior to use in embankment construction. The RCE will also submit copies of the test reports to the Quality Assurance Engineer at the Office of Materials and Research. Use only qualified laboratories that are appropriately accredited by AASHTO to perform the test procedures required by this specification.

Do not use material derived from Unclassified Excavation to construct embankments unless that material meets the requirements for Borrow Material as stated above.

(23) SECTION 203: BORROW EXCAVATION (FOR SHOULDERS):

This work shall consist of satisfactory placement of all materials necessary to bring the shoulder grade to within 2 inches of the final pavement edge grade. The Contractor shall furnish all earth material necessary to eliminate any edge of final pavement to shoulder gradient differential that exceeds 2 inches. The quantities shown on the plans are the Engineering estimate of the number of units that will be necessary for this project, actual field measurements may cause these quantities to vary.

Selected materials shall be used for this operation. The selected material shall consist of a friable material such as topsoil, etc., containing grass roots and having the properties of being comparatively porous, capable of growing grass and of a stable nature in that when compacted it will resist erosion and be capable of supporting vehicles when relatively wet. When the area where material is to be placed, is greater than 4 feet in width, it shall be scarified and/or disked to a minimum depth of 3 inches prior to placing any material. Scarifying or diskings is not required for areas less than 4 feet in width. Borrow shall be mixed with the existing scarified and/or disked shoulder material in such a manner as to provide a seed bed in accord with Section 810.15 of the Standard Specifications. The Contractor has the option of placing the borrow material (a) Prior to placing final surface course or (b) Following the placing of the finished surface course.

The method of measurement will be the volume in cubic yards, determined in accordance with Section 203 of the Standard Specifications. The Contractor, at his option, may elect to base the quantity measured on the loose volume at the point of delivery by scaling and counting the loads, with a deduction of 35 percent made for shrinkage. All cost for borrow material including obtaining, hauling, and placing shall be included in the unit price.

(24) SECTION 203: BORROW PITS:

Permitting of Borrow Pits

Prior to using borrow material from commercial or other borrow pits located wholly or in part in wetland areas, the contractor shall submit written evidence that operations to obtain fill material from the borrow pit(s) have received all appropriate and necessary authorizations from federal, state, and/or local authorities.

Permitted Borrow Pits

If the appropriate federal, state, and local authorities have issued permits, the contractor shall provide to SCDOT copies of all permits issued for such borrow pit sites.

Borrow Pits Without Section 404 Permit

For borrow pit sites for which a Section 404 permit under the Clean Water Act has not been issued, the contractor shall provide SCDOT with copies of documentation provided by the contractor or its subcontractor(s) to the U.S. Army Corps of Engineers, which shall, at a minimum, clearly define the location of the borrow pits and any wetlands on the borrow pit site; describe the proposed activities and processes that will be used to prepare the site, obtain fill material from the site, and store material at the site; and request the U.S. Army Corps of Engineers to confirm in writing that no Section 404 permit is required for those operations. No operations shall take place at the borrow sites for at least thirty days from the date of the submission of confirmation request to the U.S. Army Corps of Engineers. After thirty-one days the contractor may begin work. The contractor shall also provide copies to SCDOT of any response(s) provided by the U.S. Army Corps of Engineers to its documentation.

Responsibility

SCDOT has no obligation or duty to review, assess, evaluate, or act upon such documentation and maintains no authority or responsibility to alter, amend, reject, accept, or otherwise exercise any control over the contractor or subcontractor regarding compliance with Clean Water Act Section 404 and the implementing regulations for Section 404. Documentation submitted to SCDOT is for public information and coordination purposes only. The contractor is responsible for all costs related to the selection, operation, and/or activities at any borrow pit site in wetlands including fines, additional mitigation, and impact delays related to failure to obtain any and all necessary federal, state, and local permits and approvals for borrow pits and operations. Nothing herein shall affect in any way SCDOT's right to accept or reject any fill material not meeting the required technical specifications.

(25) SECTION 204: TEMPORARY SHORING WALL:

Subsection 204.4.5.2 is amended to include the addition of the following section:

"The retaining wall system shall be designed to limit deformations (vertical and lateral displacements) that would affect the stability or performance of any adjacent structures (MSE walls, Bridge foundations, Pavement Structure, Approach Slabs, Embankment (stage construction), etc.). Deformations that must be limited shall include, but not be limited to, vertical settlement, sliding, bulging, bowing, bending, and buckling. Design criteria for allowable deformations shall be dependent on the type of structure that will be influenced by any deformation of the temporary shoring wall. Regardless of the type of structure being retained, the deformation criteria shall not exceed 3 inches without acceptance from the Geotechnical Design Support Engineer. An instrumentation plan for monitoring deformations of the temporary shoring and any adjacent structure shall be submitted along with the shop drawings. The instrumentation plan shall indicate the maximum allowable deformations of the temporary shoring and adjacent structures. Typical instrumentation used for monitoring deformations are survey targets, settlement monuments, crack gages, inclinometers, and tilt monitors. The monitoring locations shall be established in a manner that they can be monitored consistently and obtain repeatable measurements for the entire construction period. A monitoring schedule that the Contractor will use during construction will also be included with the instrumentation plan. The Contractor shall submit periodic monitoring reports to the RCE in accordance with the approved instrumentation plan. Any changes in frequency of monitoring or report submittal must be sent to the Geotechnical Design Support Engineer for acceptance. If the initial instrumentation plan is found not to be documenting adequately the movements of the temporary shoring or adjacent structures, the Contractor will revise the instrumentation plan and resubmit the revised plan for review and acceptance. If the measured deformations exceed the maximum allowable deformations shown in the instrumentation plan, the Contractor will be required to stop work immediately, and at his own expense, correct the situation to the satisfaction of the Department prior to resumption of construction activities. Extended monitoring after construction may be required if adjacent structures have been affected by the construction. The extended monitoring of the adjacent structures shall continue until the structures have stabilized and the Department

EXHIBIT 5 – SPECIAL PROVISIONS

concurs with the results and conclusions of the monitoring report. All costs associated with developing the instrumentation plan, purchasing instrumentation, installing instrumentation, and monitoring of the instrumentation shall be included in the unit cost of the temporary shoring item.”

(26) SECTION 205: BRIDGE LIFT MATERIALS:

September 1, 2015

1.0 DESCRIPTION

The requirements of this specification shall consist of furnishing all necessary submittals and materials for providing bridge lift materials in accordance with the details shown on the plans and the requirements of the Supplemental Specifications. The bridge lift materials shall be installed at locations show on the plans, unless otherwise directed by the Department.

2.0 MATERIALS

The materials provided for under this specification shall be used for bridge lifts. Bridge lift materials shall consist of two general types, first materials that can be placed through water and those materials that are placed over soft exposed subgrades without water being present. The materials placed through water shall consist of either stone or coarse granular materials. The materials placed on soft exposed subgrades may consist of borrow excavation, stone or coarse granular materials.

2.1 Stone Materials: The stone materials shall meet the specification requirements of No. 5, No. 57 or No. 67 Coarse Aggregate (stone) as described in the current edition of the SCDOT Standard Specifications for Highway Construction. In addition, No. 4 Ballast may also be used. The No. 4 Ballast shall meet the gradation indicated in the following table.

Sieve Size	Percent Passing
2-inch	100
1-1/2-inch	90 – 100
1-inch	20 – 55
3/4-inch	0 – 15
3/8-inch	0 – 5

The stone shall consist of durable particles that are comprised of naturally occurring materials including durable marine limestone or man-made materials. The man-made materials are limited to lightweight materials that meet the gradation requirements previously indicated of No. 5, No. 57, or No. 67 stone and have a unit weight of at least 65 pounds per cubic foot. The natural materials shall have a dry unit weight of at least 105 90 pounds per cubic foot. The dry unit weight shall be a rodded unit weight determined according to AASHTO T-19M. Recycled materials may not be used.

2.2 Granular Materials: The granular materials shall meet the specification requirements for an A-1-a (AASHTO M-145) as indicated in the following table.

Sieve Analysis	Percent Passing
No. 10	50 max.
No. 40	30 max.
No. 200	15 max.
Plasticity Index	6 max.
Organics	1 max.

The granular materials shall consist of durable, naturally occurring particles. The granular materials shall have a dry unit weight of at least 110 pounds per cubic foot. The

EXHIBIT 5 – SPECIAL PROVISIONS

dry unit weight shall be determined according to AASHTO T-99. Recycled materials may not be used.

2.3 Borrow Excavation Materials: Borrow excavation materials used as a bridge lift shall be limited to A-1, A-2 and A-3 materials (AASHTO M-145). The borrow excavation materials shall meet the requirements as described in the current edition of the SCDOT Standard Specifications for Highway Construction.

2.4 Submittals: The contractor is required to submit copies of gradation testing to the Department prior to delivery of the material to the site and at the discretion of the RCE as placement proceeds, if in the opinion of the RCE additional verification of the gradation is required.

3.0 METHOD OF MEASUREMENT

Stone bridge lift materials shall be measured by the ton (TON) when included in the Contract. Granular bridge lift materials shall be measured by the cubic yard (CY) when included in the Contract. The quantity of granular bridge lift material includes the material acceptably excavated and is measured in its original position and determined from cross-sections by the method of average-end-areas, complete and accepted. Borrow excavation bridge lift materials shall be measured and included in the total borrow material required for the project.

4.0 BASIS OF PAYMENT

Unless otherwise specified, payment for the accepted quantity of material, as specified herein, measured in accordance with this specification, is determined using the contract unit bid price for the applicable pay item. Payment is full compensation for obtaining, hauling and placing the material and all other materials, labor, equipment, tools, supplies and incidentals necessary to satisfactorily complete the work as required in the Plans, Project Specifications and other terms in the Contract.

Where the Contractor is required to furnish the borrow pits for granular bridge lift material, payment for the granular bridge lift material includes the cost of the borrow pit, clearing and grubbing of pits, necessary haul roads, hauling of the borrow material to the designated location on the project and for all other pertinent stipulations stated above.

Payment of borrow excavation bridge lift material shall be included in the quantity of borrow excavation used on the project.

Payments shall be made under:

Item No.	Pay Item	Pay Unit
2052010	Stone Bridge Lift Material	TON
2052020	Granular Bridge Lift Material	CY

(27) SECTION 205: LIGHTWEIGHT AGGREGATES:

July 23, 2010

1.0 Description.

This work shall consist of furnishing, loading, hauling, placing and compacting lightweight aggregates (either man-made or natural) for use as fill materials in accordance with these specifications. The lightweight aggregate must be manufactured by expanding shale, clay, or slate in a rotary kiln operation or be naturally made. Wood fiber, blast furnace slag, fly ash, shredded tires, or boiler slag will not be allowed. The material must be sub angular to angular conforming to ASTM C 330 (latest edition). The material requirements presented in this specification are appropriate for borrow materials placed in embankments or placed as

EXHIBIT 5 – SPECIAL PROVISIONS

retained materials. If lightweight aggregates are used as reinforced backfill materials for the construction of Mechanically Stabilized Earth (MSE) walls or other reinforced soil structures, additional material properties, construction, and testing frequency requirements may be required based on the appropriate specifications.

2.0 Material.

The Lightweight aggregate must have a proven record of durability, be non-corrosive, and conform to the following requirements:

- pH (AASHTO T-289): pH values shall range between 5 and 10.
- Organic Content (AASHTO T-267): Organic content shall be less than 0.1 percent (weight of organic material to weight of total sample).
- Soundness Loss (AASHTO T104): Soundness loss shall be less than 15% when subjected to 5 cycles of Sodium Sulfate.
- Los Angeles Abrasion (AASHTO T96): Abrasion loss shall be less than 45%.
- Chloride Content (AASHTO T291): Chloride content shall be less than 100 ppm.
- Sulfate (AASHTO T-290): Sulfate content shall be less than 200 ppm.
- Resistivity (ASTM D1125): Resistivity must be greater than 3000-ohm-cm. If resistivity is greater than 5000-ohm-cm, chloride and sulfate requirements and testing are waived.
- Absorption (AASHTO T19): Absorption must be less than 6%.
- Gradation (ASTM 136): The gradation will be as shown in the following Table. Other gradations may be acceptable upon approval by the Engineer.

Table – Lightweight Aggregate Gradation

Sieve Size or Number	Percent Passing
¾ inch	100
½ inch	90 – 100
3/8 inch	50 – 90
No. 4	0 – 50
No. 8	0 – 20
No. 16	Less than 10
No. 30	Less than 10
No. 50	Less than 5
No. 100	Less than 5

- The coefficient of uniformity, C_u , shall be 4 or greater. The coefficient of uniformity, C_u , shall be computed as follows:

$$C_u = \frac{D_{60}}{D_{10}}$$

Where D_{60} is the particle diameter at 60% passing and D_{10} is the particle diameter at 10% passing. Written approval from the DOC will be required to use soils with a coefficient of uniformity, C_u , less than 4.

- Aggregate loose unit weight (ASTM C29): The loose unit weight must be less than 45 lbs/ft³.
- In-place density: (ASTM D4253, and D4254): The in-place compacted dry unit weight must be between 55 and 60 lbs/ft³. Material must be compacted to a minimum 65% relative density as determined by ASTM D4253 and D4254. Use a vibratory table when determining the maximum index density and unit weight in accordance with ASTM D4253. Determine the minimum index density and unit weight in accordance with ASTM D4254.
- Angle of Internal Friction (AASHTO T 236): The minimum angle of internal friction must be 40 degrees. Test a saturated representative sample (with particles larger than larger than 0.75 inch removed) in a round or square shear box that is a

EXHIBIT 5 – SPECIAL PROVISIONS

minimum of 12 inches across. Test sample shall be compacted to a minimum 65% relative density as determined by ASTM D4253 and D4254.

3.0 Construction.

Place the lightweight fill in uniform layers. When required by the Engineer, compact each layer using vibratory compaction equipment weighing no more than 10 tons. Place layers no more than 12 inches in depth loose thickness and compact. Compact with three passes of an 8 – 10 ton vibratory roller in the vibratory mode if necessary, or as directed by the Engineer. In confined areas use vibratory plate compaction equipment (5 hp to 20 hp) with a minimum of two passes in 6" lifts for a 5 hp plate and 12" lifts for a 20 hp plate. The contractor must take all necessary precautions when working on or near the lightweight fill to ensure that the material is not over compacted. Construction equipment, other than for placement and compaction, must not operate on the exposed lightweight fill. Low ground pressure equipment (D6 LGP or lighter) is recommended for spreading and placing the lightweight aggregate.

4.0 Testing Frequency.

All soil property requirements shall be tested during initial source evaluation or if a change in source is requested. Lightweight aggregate material shall be sampled once every 2,000 cubic yards and tested for gradation and pH. Lightweight aggregate material shall be sampled once every 5,000 cubic yards and tested for internal friction angle, organic content, resistivity, chloride content, and sulfate content. Chloride and sulfate content testing will not be required if resistivity test results indicate 5000 ohm-cm or greater. The internal friction angle shall be tested every 2,000 cubic yards if the gradation indicates that the coefficient of uniformity, C_u , is less than 4. A variation in testing frequency may be required if a variation in material gradation or composition is observed.

5.0 Measurement and Payment.

Measurement of lightweight aggregate shall be the actual volume in-place at the project site. All costs for furnishing, loading, hauling, placing and compacting lightweight aggregates (either man-made or natural) shall be included in the unit price of the lightweight aggregates.

Payment will be made under:

Item No.	Pay Item	Pay Unit
2033020	Borrow Excavation (Lightweight)	CY

(28) SECTION 205: GEOGRID SOIL REINFORCEMENT:

April 14, 2015

1.0 Description

This work shall consist of furnishing primary geogrid soil reinforcement in accordance with these specifications.

2.0 Reference Documents

The latest edition of the test standards shall be used. Substitution of standards will require the prior written approval of the Research and Materials Engineer.

3.0 Material

Geogrid design requirements shall be as shown in the plans and specified in the design drawings. Geogrid soil reinforcement shall consist of a regular network of integrally connected polymer tensile elements with aperture geometry sufficient to permit significant mechanical interlock with the surrounding soil, aggregate, or other material. The structure of the geogrid reinforcements shall be dimensionally stable and able to retain its geometry under construction stresses and shall have high resistance to damage during construction, to

EXHIBIT 5 – SPECIAL PROVISIONS

ultraviolet degradation, and to all forms of chemical and biological degradation encountered in the soil being reinforced.

3.1 Primary Reinforcement

Primary geogrids shall provide the following minimum allowable long-term reinforcement tension load, T_{al} .

Property	Method	P1 ⁽³⁾	P2	P3	P4	P5	P6	P7	P8
Allowable Long-term Tension Load, T_{al} ^{(1) (2)} (lb/ft)	FHWA NHI-00-043	450	800	1450	2300	3000	3600	4000	9000

(1) Minimum T_{al} in machine direction unless otherwise specified

(2) Minimum pullout friction factor $F^*=C_i \tan \Phi$, where soil interaction coefficient, $C_i \geq 0.6$

(3) Biaxial Geogrid – Minimum T_{al} in strong direction, minimum T_{al} in weak direction is 360 lb/ft.

where $T_{al} = \frac{T_{ult}}{RF}$ and $RF = RF_{CR} \times RF_D \times RF_{ID}$ and $RF \geq 3.0$

3.2 Secondary Reinforcement

Secondary reinforcement, Type S1, shall meet the following minimum average physical properties:

Property	Method	Value
1. Tensile Strength ⁽¹⁾		
a. 5% strain, lb/ft ⁽²⁾	ASTM D 4595	800
b. Ultimate Tensile Strength, T_{ult} (lb/ft)	ASTM D 4595	1400
c. Allowable Long-Term Strength, T_{al} (lb/ft)	FHWA NHI-00-043	200
2. Apparent Opening Size	ASTM D 4751	>50, <80

NOTE: ⁽¹⁾ In direction perpendicular to the slope face.

⁽²⁾ No offset allowance is permitted.

4.0 Certification

Prior to construction the Contractor shall submit to the Geotechnical Engineer of Record (GEOR) a Certification Package prepared by the geogrid reinforcement manufacturer. The Contractor shall allow 15 calendar days from the day the submittals are received by the GEOR for review and acceptance. The Certification shall state that the furnished geogrid soil reinforcement is in full compliance with the design requirements as stated in this specification and the design drawings and is fit for use in long-term critical soil reinforcement applications. The submittal shall certify the following values for each geogrid soil reinforcement used on the project:

1. The allowable long-term tensile load, T_{al} , for geogrid soil reinforcements
2. The ultimate tensile strength, T_{ULT} , (MARV) for geogrid soil reinforcements.
3. The geogrid's pullout coefficients (F^* , α)

The manufacturer shall also provide written certification that the material is capable of withstanding direct exposure to sunlight for 120 days with no measurable deterioration as measured per ASTM D 4355. The Contractor's submittal package shall include, but not be

limited to, actual test results for tension, creep, durability, construction damage, joint strength, pullout and quality control. A person having the legal authority to bond the manufacturer shall attest to the certificate. Any tests required shall be performed at no additional cost to the Department. If in the opinion of the GEOR, the required documentation is not provided for individual reduction factors (RF) or pullout coefficients (F^* , α), default values for these design parameters shall be used in accordance with this specification.

The submittal shall certify the following values and document for each geogrid soil reinforcement used on the project:

4.1 Ultimate Tensile Strength (T_{ult}):

The ultimate tensile strength, T_{ult} , shall be determined from wide width tensile tests (ASTM D 4595) or rib tensile test for geogrids (ASTM D 6637). Geogrid samples tested in accordance with ASTM D 4595 shall have at least two geogrid apertures and a minimum gage length of 4 inches. All geogrid strength tests (ASTM D 4595 and ASTM D 6637) shall be conducted at a strain rate of 10% per minute based on actual gage length necessary to meet the testing sample dimension requirements. Laboratory test results documenting the ultimate tensile strength, T_{ult} , in the reinforcement direction shall be based on the minimum average roll values (MARV) for the product.

4.2 Allowable Long-term Tensile Load (T_{al}):

The allowable tensile load, T_{al} , per unit width of geosynthetic soil reinforcement in accordance to the backfill type used shall be computed as follows:

$$T_{al} = \frac{T_{ult}}{RF}$$

4.3 Reduction Factor (RF):

The total reduction factor, RF, is the combined reduction factor for long-term degradation due to installation damage, creep, and durability. The total reduction factor, RF, shall be defined as follows:

$$RF = RF_{ID} \times RF_{CR} \times RF_D \geq 3.0$$

The individual reduction factors shall be documented in accordance with the site conditions, design calculations, and specifications. When sufficient documentation is not provided for individual reduction factors, RF_{ID} , RF_{CR} , and RF_D , a reduction factor RF of 7.0 shall be used. The reinforcement manufacturer shall certify and document the individual reduction factors as follows:

4.3.1 Installation Damage Reduction Factor (RF_{ID}):

The reduction factor for installation damage, RF_{ID} , shall be documented by field and laboratory test results and literature review, as described in ASTM D 5818 for the reinforced backfill specified or for more severe soils. Samples subjected to installation damage shall be tested for tensile strength and deformation characteristics in accordance with ASTM D 4595 (modified for geogrid testing). Recommended values for reduction factors for installation damage (RF_{ID}) for various soils shall also be documented. The minimum installation damage reduction factor, RF_{ID} , shall be 1.1, regardless of product specific test results.

4.3.2 Creep Reduction Factor (RF_{CR}):

Laboratory test results documenting creep performance over a range of load levels, for a minimum duration of 10,000 hours based on tension creep test (ASTM D 5262) shall be required. Creep test samples shall be of sufficient width to be representative of overall product creep response (fiber creep testing will not be accepted).

The creep-limiting strength, T_1 , shall be based on extrapolating the 10,000 hours (or longer duration) tension creep tests to a 75-year design life, unless a 100-year design life is specified in the plans. The creep extrapolation method shall be based on methods described in FHWA NHI-00-43, *"Mechanically Stabilized Earth Walls and Reinforced Soil Slopes"* - Appendix "B". Laboratory test results and extrapolation methodology shall be documented.

The reduction factor for creep, RF_{CR} , is defined as the ratio of the average lot specific ultimate tensile strength, T_{ULTLOT} , to the creep-limiting strength, T_1 . The average lot specific ultimate tensile strength, T_{ULTLOT} , for the lot of material used for creep testing, T_{ULTLOT} , shall be determined from wide width tensile test, ASTM D 4595, (modified for geogrid testing).

4.3.3 Durability Reduction Factor (RF_D):

The total reduction factor for durability, RF_D , shall be defined as the combined effects of chemical and biological degradation. Laboratory test results, extrapolation techniques, and a comprehensive literature review shall document the reduction factor for durability for all material components in accordance with FHWA NHI-00-044, *"Corrosion/Degradation of Soil Reinforcements for Mechanically Stabilized Earth Walls and Reinforced Soil Slopes"*. The minimum durability reduction factor, RF_D , shall be 1.1, regardless of product specific test results.

4.4 Soil Reinforcement Pullout Coefficients (F^* , α)

The Certification Package shall document the pullout coefficients (F^* , α) meet or exceed the required coefficients necessary to obtain the T_{al} provided above.

The pullout friction factor, F^* , and the scale effect correction factor, α , shall be documented by laboratory testing from pullout tests. Pullout testing shall be conducted for site-specific materials or for materials representative of the reinforced backfill at confining pressures specified by the Engineer. When laboratory tests are used from representative soils, the representative soils shall be documented by providing the soil's angle of internal friction, gradation, and coefficient of uniformity ($C_u = D_{60}/D_{10}$). Recommended pullout coefficients for various soil types shall also be documented. The pullout coefficients shall be determined by using the quick effective stress pullout tests ("Measuring Geosynthetic Pullout Resistance in Soil" per ASTM D 6706) and through-the-junction creep testing of the geogrid per ASTM D 5262. The soil interaction coefficient, C_i , shall be documented when computing the pullout friction factor, F^* . When sufficient documentation is not provided for pullout coefficients, F^* and α , and the coefficient of uniformity, C_u , is greater or equal to 4, the default values indicated in this specification can be used. If the coefficient of uniformity of the reinforced backfill is less than 4, laboratory pullout test shall be required to determine pullout friction factor, F^* , and the default scale effect factor, α .

5.0 Manufacturing Quality Control

The Contractor shall provide to the RCE a manufacturing quality control certificate and conformance testing results for all geosynthetic soil reinforcement delivered to the site. Sampling and conformance testing shall be in accordance with ASTM D 4354. Geosynthetic product acceptance shall be based on ASTM D 4759. Geogrid samples tested in accordance with ASTM D 4595 shall have at least two geogrid apertures and a minimum gage length of 4 inches. All geogrid strength tests (ASTM D 4595 and ASTM D 6637) shall be conducted at a strain rate of 10% per minute based on actual gage length necessary to meet the testing sample dimension requirements. Laboratory test results documenting the ultimate tensile strength, T_{ult} , in the reinforcement direction shall be based on the minimum average roll values (MARV) for the product. Conformance testing of the applicable index testing shown in Table 5.0 shall be provided for all geosynthetic

EXHIBIT 5 – SPECIAL PROVISIONS

soil reinforcement. The quality control certificate shall include roll numbers and identification, sampling procedures, and results of the conformance testing with a description of test methods used. The geogrid manufacturer shall have a manufacturing quality control program that includes QC testing no less frequently than each 200,000 sf (20,000sm) of production.

Table 5.0 – Applicable Index Testing

Type	Property	Test Method	Criteria
Polypropylene (PP)	UV Oxidation Resistance	ASTM D 4355	Minimum 70% strength retained after 500 hrs. in weatherometer
	Melt Flow Rate	ASTM D 1238	≤ 12 g/10 min
Polyethylene (HPDE)	UV Oxidation Resistance	ASTM D 4355	Minimum 70% strength retained after 500 hrs. in weatherometer
	Melt Flow Rate	ASTM D 1238	< 0.4 g/10 min
	Specific Gravity	ASTM D 792	1.2 Average
Polyester (PET)	Hydrolysis Resistance	Intrinsic Viscosity Method (ASTM D 4603 and GRI Test Method GG8) with Correlation or Determine Directly Using Gel Permeation Chromatography	Minimum Number Average Molecular Weight of 25,000
	Hydrolysis Resistance	GRI GG7	Maximum Carboxyl End Group (CEG) Content of 30
All Polymers	Survivability	Weight per Unit Area ASTM D 5261	Minimum 270 g/m ² (7.9 oz/yd ²)
	% Post Consumer Recycled Material by Weight	Certification of Material Used	Maximum 0%

6.0 Measurement and Payment. All costs for installing the geogrid soil reinforcement (primary and secondary) is to be included in the amount bid for the pay items below.

Measurement of primary and secondary geogrid soil reinforcement is on a square yard basis and will be computed based on the total area of primary or secondary geogrid soil reinforcement shown in the plans, exclusive of the area of geogrids used in any overlaps. Overlaps and any geogrid waste are an incidental item. The quantity of primary geogrid soil reinforcement (biaxial or uniaxial) shall be paid at the contract unit price for Geogrid Reinforcement.

EXHIBIT 5 – SPECIAL PROVISIONS

Payment will be made under:

Item No.	Pay Item	Pay Unit
2037000	Geogrid Reinforcement (Uniaxial)	SY
2037010	Geogrid Reinforcement (Biaxial)	SY

(29) SECTION 205: HIGH-STRENGTH GEOTEXTILE FOR EMBANKMENT REINFORCEMENT:

April 21, 2015

1.0 DESCRIPTION

This work shall consist of furnishing and installing construction geotextiles in accordance with the details shown in the plans, specifications, or as directed by the RCE.

2.0 MATERIALS

A geotextile is defined as any permeable polymeric textile used with foundation, soil, rock, earth, or any other geotechnical engineering related material, as an integral part of a civil engineering project, structure, or system. Use geotextiles and thread used in joining geotextiles manufactured from fibers consisting of long-chain polymers, composed of at least 95 percent by weight of polyolefins or polyesters. Use geotextiles with fibers formed into a stable network such that the fibers or yarns retain their dimensional stability relative to each other, including selvages (edges) during shipping, handling, placement, and in service. Use geotextile free from defects or tears.

A. Minimum Average Roll Values: All property values, with the exception of Apparent Opening Size (AOS), represent Minimum Average Roll Values (MARV) in the weakest principal direction. Provide geotextiles whose average test results from any roll sampled in a lot for conformance or quality assurance testing meets or exceeds minimum values provided in this Section.

B. Apparent Opening Size: Values for Apparent Opening Size (AOS) represent maximum average roll values. Acceptance will be based on ASTM D 4759.

C. Reinforcement Geotextile: Use reinforcement geotextile within existing and/or proposed fills for slope reinforcement.

Furnish geotextiles meeting the property requirements outlined in Table 1.

Table 1: High Strength Geotextile Properties (Design Requirements)^{1,2}

<u>Property</u>	<u>Test Method</u>	<u>Geotextile Property Requirements</u>
Long-Term Design Strength, T_{al} , MD		22,800 lb/ft
Long-Term Design Strength, T_{al} , XD		2,280 lb/ft
Sewn Seam Breaking Strength ³	ASTM D4884	900 lbs/ft
AOS	ASTM D4751	$\leq (1.0 \text{ to } 2.0)D_{85(\text{soil})}$
Permeability	ASTM D4491	$\geq 10K_{\text{soil}}$
Default Pullout Friction Factor, F^*	ASTM D6706	$0.6 \tan \phi$
Default Alpha, α	ASTM D6706	0.6
Ultraviolet Stability	ASTM D4355	$\geq 50\%$ after 500 hrs of exposure

- Notes: 1. The test procedures shall conform to the most recently approved ATSM geotextile test procedures.
 2. All numeric values represent Minimum Average Roll Value (MARV).
 3. Applies to factory or field sewn seams.

2.1 Source Approval and Certification.

Prior to construction, the Contractor shall submit to the Resident Construction Engineer (RCE) a Certification Package prepared by the geotextile reinforcement manufacturer. The Contractor shall allow 21 calendar days from the day the submittals are received by the RCE for review and acceptance. Submit the following information regarding each geotextile proposed for use:

EXHIBIT 5 – SPECIAL PROVISIONS

- Manufacturer's name and current address;
- Full product name/number, including roll number;
- Geosynthetic material (i.e. polymer type) and structure (including fiber/yarn type);
- Proposed geotextile use(s); and
- Certified test results for the properties outlined in Table 1 and below in Section 2.

The Certification shall state that the furnished geotextile soil reinforcement is in full compliance with the design requirements as stated in this specification and the design drawings and is fit for use in long-term critical soil reinforcement applications. In addition to the minimum required properties in Table 1, the submittal shall also certify the following values for each geotextile soil reinforcement used on the project:

1. The ultimate tensile strength, T_{ULT} , (MARV) for geogrid soil reinforcements, MD/XD
2. The tensile strength at 5% strain, MD
3. The creep reduced tensile strength, MD
4. The geotextile's pullout coefficients (F^* , α)

The Contractor's submittal package shall include, but not be limited to, actual test results for tension, creep, durability, construction damage, joint/seam strength, pullout and quality control. A person having the legal authority to bond the manufacturer shall attest to the certificate. Any tests required shall be performed at no additional cost to the Department. If in the opinion of the RCE, the required documentation is not provided for individual reduction factors (RF) or pullout coefficients (F^* , α), default values for these design parameters shall be used in accordance with this specification.

2.1.1 Ultimate Tensile Strength (T_{ult}):

The ultimate tensile strength, T_{ult} , shall be determined from wide width tensile tests (ASTM D 4595). Geotextile samples tested in accordance with ASTM D 4595 shall be with an 8-inch width specimen, or a 4-inch specimen width with correlation to an 8-inch width. Correlation methodology shall be submitted to, and is subject to acceptance by the RCE. All geotextile strength tests (ASTM D 4595 and ASTM D 6637) shall be conducted at a strain rate of 10% per minute based on actual gage length necessary to meet the testing sample dimension requirements. Laboratory test results documenting the ultimate tensile strength, T_{ult} , in the reinforcement direction shall be based on the minimum average roll values (MARV) for the product.

2.1.2 Long-Term (Allowable) Design Tensile Strength (T_{al}):

The allowable tensile load per unit width of geotextile soil reinforcement, T_{al} , in accordance to the backfill type used shall be computed as follows:

$$T_{al} = \frac{T_{ult}}{RF}$$

2.1.3 Reduction Factor (RF):

The total reduction factor, RF, is the combined reduction factor for long-term degradation due to installation damage, creep, and durability. The total reduction factor, RF, shall be defined as follows:

$$RF = RF_{ID} \times RF_{CR} \times RF_D \geq 3.0$$

The individual reduction factors shall be documented in accordance with the site conditions, design calculations, and specifications. When sufficient documentation

is not provided for individual reduction factors, RF_{ID} , RF_{CR} , and RF_D , a reduction factor RF of 7.0 shall be used. The reinforcement manufacturer shall certify and document the individual reduction factors as follows:

2.1.4 Installation Damage Reduction Factor (RF_{ID}):

The reduction factor for installation damage, RF_{ID} , shall be documented by field and laboratory test results and literature review, as described in ASTM D 5818 for the reinforced backfill specified or for more severe soils. Samples subjected to installation damage shall be tested for tensile strength and deformation characteristics in accordance with ASTM D 4595. Recommended values for reduction factors for installation damage (RF_{ID}) for various soils shall also be documented. The minimum installation damage reduction factor, RF_{ID} , shall be 1.1, regardless of product specific test results.

2.1.5 Creep Reduction Factor (RF_{CR}):

Laboratory test results documenting creep performance over a range of load levels, for a minimum duration of 10,000 hours based on tension creep test (ASTM D 5262) shall be required. Creep test samples shall be of sufficient width to be representative of overall product creep response (fiber creep testing will not be accepted).

The creep-limiting strength, T_i , shall be based on extrapolating the 10,000 hours (or longer duration) tension creep tests to a 75-year design life, unless a 100-year design life is specified in the plans. The creep extrapolation method shall be based on methods described in FHWA NHI-10-025, *"Design and Construction of Mechanically Stabilized Earth Walls and Reinforced Soil Slopes"* - Appendix "D". Laboratory test results and extrapolation methodology shall be documented.

The reduction factor for creep, RF_{CR} , is defined as the ratio of the average lot specific ultimate tensile strength, T_{ULTLOT} , to the creep-limiting strength, T_i . The average lot specific ultimate tensile strength, T_{ULTLOT} , for the lot of material used for creep testing, T_{ULTLOT} , shall be determined from wide width tensile test, ASTM D 4595.

2.1.6 Durability Reduction Factor (RF_D):

The total reduction factor for durability, RF_D , shall be defined as the combined effects of chemical and biological degradation. Laboratory test results, extrapolation techniques, and a comprehensive literature review shall document the reduction factor for durability for all material components in accordance with FHWA NHI-09-087, *"Corrosion/Degradation of Soil Reinforcements for Mechanically Stabilized Earth Walls and Reinforced Soil Slopes"*. The minimum durability reduction factor, RF_D , shall be 1.1, regardless of product specific test results.

2.1.7 Soil Reinforcement Pullout Coefficients (F^* , α):

The Certification Package shall document the pullout coefficients (F^* , α) meet or exceed the required coefficients necessary to obtain the T_{ai} provided above where,

F^* = Minimum pullout friction factor = $C_i \tan \Phi$,

C_i = Soil interaction coefficient ≥ 0.6

Φ = Soil Angle of Internal Friction

The pullout friction factor, F^* , and the scale effect correction factor, α , shall be documented by laboratory testing from pullout tests. Pullout testing shall be conducted for site-specific materials or for materials representative of the reinforced backfill at confining pressures specified by the Engineer. When

laboratory tests are used from representative soils, the representative soils shall be documented by providing the soil's angle of internal friction, gradation, and coefficient of uniformity ($C_u = D_{60}/D_{10}$). Recommended pullout coefficients for various soil types shall also be documented. The pullout coefficients shall be determined by using the quick effective stress pullout tests ("Measuring Geosynthetic Pullout Resistance in Soil" per ASTM D 6706). The soil interaction coefficient, C_i , shall be documented when computing the pullout friction factor, F^* . When sufficient documentation is not provided for pullout coefficients, F^* and α , and the coefficient of uniformity, C_u , is greater or equal to 4, the default values indicated in this specification can be used. If the coefficient of uniformity of the reinforced backfill is less than 4, laboratory pullout test shall be required to determine pullout friction factor, F^* , and the default scale effect factor, α .

2.2 Sample Approval.

To confirm that the on-site geotextile meets the property values specified, random samples shall be submitted to the RCE for evaluation. The machine direction shall be marked clearly on each sample submitted for evaluation. The machine direction is defined as the direction perpendicular to the axis of the roll.

Cut a sample from the geotextile roll with the minimum dimensions of 4 feet by the full width of the roll beyond the first wrap. The geotextile samples shall be cut from the roll with scissors, sharp knife, or other suitable method that produces a smooth edge and does not cause geotextile ripping or tearing. Submit a manufacturer's certificate of compliance signed by an authorized manufacturer's official. The certificate must attest that the geotextile meets all the Minimum Average Roll Value (MARV) requirements specified in Table 1 as evaluated under the manufacturer's quality control program. Geotextiles supplied for construction of the project shall be certified in accordance with the following criteria. The tests described in the specification shall be conducted by the manufacturer or by an approved independent testing laboratory on samples taken from the same lot number as the material actually shipped to the project and at the specified frequency. The manufacturer or independent testing laboratory shall maintain the appropriate accreditations and must be preapproved by the Department. All rolls shall be marked with individual and distinct roll numbers. All roll numbers shall have traceable certified mill test reports from the given lot that they were manufactured. These test reports must be supplied to the Department prior to installation of any geotextile materials. After the sample and the required information have been submitted to the RCE, allow 30 calendar days for evaluation.

Product acceptance is determined by comparing the average test results of all specimens within a given sample to the Minimum Average Roll Values (MARV) listed in Table 1. Install geotextiles only after the material has been tested and/or evaluated and accepted. Replace all geotextiles installed prior to acceptance that do not meet specifications at Contractor's expense.

2.2.1 Sewn Seam Approval.

If the geotextile seams are to be sewn in the field, the Contractor shall provide a section of sewn seam that can be sampled by the RCE before the geotextile is installed. The sewn seam shall be in accordance with ASTM 6193.

The seam sewn for sampling shall be sewn using the same equipment and procedures as will be used to sew the production seams. The seam sewn for sampling must be at least 6 feet in length. If the seams are sewn in the factory, the Contractor shall provide samples of the factory seam at random from any of the rolls to be used. Regardless of whether the seam is to be sewn in the factory or the field, the manufacturer and/or Contractor shall certify that the strength meets the requirement set forth in Table 1. If seams are to be sewn in both the machine

and cross-machine direction, provide samples of seams from both directions. The seam assembly description shall be submitted by the Contractor to the Engineer and will be included with the seam sample obtained for testing. This description shall include the seam type, stitch type, sewing thread type(s), and stitch density.

If sewn seams are used for seaming the geotextile, use thread that consists of high strength polypropylene or polyester. Do not use nylon thread. Use thread that is of contrasting color to that of the geotextile itself.

If the manufacturer can provide a T_{al} MD that is greater than the sum of the required T_{al} MD and sewn seam breaking strength (for each specified in the project plans), the sewn seams may be eliminated and a minimum overlap of 1 foot may be used.

2.3 Identification, Shipment and Storage.

Conform to ASTM D 4873, *Standard Guide for Identification, Storage, and Handling of Geotextiles*. Clearly label each roll of geotextile shipped to the project with the name and address of the manufacturer, full product name/number, quantity, and roll number.

The RCE will reject materials that are mislabeled or misrepresented. Wrap each roll with a material that protects the geotextile, including ends of the roll, from damage due to shipment, water, sunlight, and contaminants. Maintain the protective wrapping during periods of shipment and storage. Do not damage the geotextile or wrapping when unloading or transferring from one location to another. Do not drag the rolls.

During storage, elevate geotextile rolls off the ground and adequately cover to protect them from the following:

- Site construction damage;
- Precipitation;
- Ultraviolet radiation including sunlight;
- Chemicals that are strong acids or strong bases;
- Flames including welding sparks, temperatures in excess of 140 °F (60 °C); and
- Mud, dirt, dust, debris and any other environmental condition that may damage the physical property values of the geotextile.

3.0 CONSTRUCTION REQUIREMENTS

3.1 General.

Prepare the surface on which the geotextile is to be placed so that no damage occurs to the geotextile. Do not drive or operate any construction equipment on the geotextile. Dispose of material with defects, rips, holes, flaws, deterioration, or other damage. Do not use defective material in the work. The manufacturer shall be present on site for a minimum of two days of geotextile installation such that the manufacturer observes any field-sewn seams.

3.2 Installation Plan.

Within thirty (30) calendar days after award of the contract or no later than thirty (30) calendar days before beginning high-strength geotextile installation, the Contractor shall submit to the Department for review a high-strength geotextile installation plan that includes as a minimum the following information:

- a) The Contractor shall certify and provide proof to the Department of experience in the work described. The Contractor shall have successfully installed at least 500,000 square yards of any geotextile that has sewn seams during the last five years. In addition, the Contractor shall have successfully completed at least five

projects within the last five years of similar size and complexity to that of the Project.

The Contractor's experience shall be documented by providing a project summary that includes for each referenced project, the project start and completion dates, total quantity of geotextile installed (specifically indicate if high-strength geotextile installed), and a detailed description of the project, site conditions, and subsurface conditions. The project description shall include details of the geotextile materials, the equipment and technique used to install the geotextiles, the average and maximum area of geotextile installed, the client name and address, the name and telephone number of the representative of the consultant and owner for whom the work was performed and who can attest to the successful completion of the work, and any other information relevant to demonstrating the Contractor's qualifications.

- b) Resume of supervisor documenting experience and qualifications in the installation of both normal and high-strength geotextile. The Contractor shall have a full-time supervisor who has been in responsible charge of supervising geotextile installation operations for at least five projects in the last five years. The supervisor shall be present at the work site at all times during installation operations. The acceptability of the supervisor, as well as any replacement for the supervisor, will be subject to the approval of the Department.
- c) Shop drawings showing the planned locations and elevations of all high-strength geotextiles. The installation sequence shall also be provided including any required staging. The shop drawings shall also show the location of the bridge abutment, and the limits of the final embankment and construction staging.
- d) Detailed description of proposed installation procedures.
- e) Proposed methods and equipment for sewn seams.

3.3 Site Preparation.

Prepare the installation site by clearing, grubbing, and excavating or filling the area to the design grade. This includes removal of topsoil or vegetation. The RCE will identify soft spots and unsuitable areas during site preparation. This may include but not be limited to proof-rolling specific areas defined by the RCE. Excavate these areas and backfill with approved borrow or bridge lift material and compact as specified. The area to be covered by the geotextile shall be graded to a smooth, uniform condition free from ruts, potholes, and protruding objects such as rocks or sticks.

The Contractor may construct a working platform, up to 2 feet in thickness, in lieu of grading the existing ground surface. A working platform is required where stumps or other protruding objects which cannot be removed without excessively disturbing the subgrade are present. These areas shall be prepared in accordance with the 2007 Standard Specifications for Highway Construction. The stumps shall be covered with at least 6 inches of fill before placement of the first geotextile layer.

3.4 Geotextile Placement.

The geotextile shall be spread immediately ahead of the covering operation. The geotextile shall be laid with the machine direction perpendicular or parallel to centerline as shown in Plans. All seams shall be sewn. Seams to connect the geotextile strips end to end will not be allowed. The geotextile shall not be left exposed to sunlight during installation for a total of more than 14 calendar days. The geotextile shall be laid smooth without excessive wrinkles. Under no circumstances shall the geotextile be dragged through mud or over sharp objects, which could damage the geotextile.

EXHIBIT 5 – SPECIAL PROVISIONS

Small soil piles or the manufacturer's recommended method shall be used as needed to hold the geotextile in place until the specified cover material is placed. Remove wrinkles and folds by pulling the geotextile taut as required.

Should the geotextile be torn or punctured or the sewn joints disturbed, as evidenced by visible geotextile damage, subgrade pumping, intrusion, or roadbed distortion, the backfill around the damaged or displaced area shall be removed and the damaged area repaired or replaced by the Contractor at no expense to the Department. The repair shall consist of a patch of the same type of geotextile placed over the damaged area. The patch shall be sewn at all edges.

If geotextile seams are to be sewn in the field or at the factory, the seams shall consist of two parallel rows of stitching, or shall consist of a J-seam, Type SSn-2. The two rows of stitching shall be 1 inch apart with a tolerance of plus or minus 0.5 inches and shall not cross, except for restitching. The stitching shall be a lock-type stitch. The minimum seam allowance, i.e., the minimum distance from the geotextile edge to the stitch line nearest to that edge, shall be 1.5 inches if a flat or prayer seam, Type SSa-2, is used. The minimum seam allowance for all other seam types shall be 1 inches. The seam, stitch type, and the equipment used to perform the stitching shall be as recommended by the manufacturer of the geotextile and as approved by the RCE.

The seams shall be sewn in such a manner that the seam can be inspected readily by the RCE or his representative. The seam strength will be tested and shall meet the requirements stated herein.

3.5 Fill Placement.

Embankment construction shall be kept symmetrical at all times to prevent localized bearing capacity failures beneath the embankment or lateral tipping or sliding of the embankment. Place fill over the geotextile by dumping onto previously placed material and pushing the material into place. Stockpiling of fill on the geotextile will not be allowed.

The cover material shall be placed on the geotextile in such a manner that a minimum of 8 inches of uncompacted material will be between the equipment tires or tracks and the geotextile at all times. Construction vehicles shall be limited in size and weight such that rutting in the initial lift above the geotextile is not greater than 3 inches deep, to prevent overstressing the geotextile. Do not blade material down to remove ruts. Fill any ruts or depressions with additional material and compact to the specified density. Turning of vehicles on the first lift above the geotextile will not be permitted. If the geotextile is being placed on soft ground, compaction of the first lift above the geotextile shall be limited to routing of placement and spreading equipment only. If groundwater is present within 2 feet of the any lift, vibratory compaction shall not be used. If the subgrade is very soft with an undrained shear strength less than 500 psf minimize pile heights to less than 3 feet and spread piles as soon as possible after dumping to minimize the potential for localized subgrade failure due to overloading of the subgrade.

A sandy material that meets the requirements of an A-2 AASHTO soil classification shall be the only borrow excavation soil allowed for placement between the lowest elevation geotextile and the bottom of the pavement section. The embankment fill soils shall be compacted in accordance with the 2007 Standard Specifications for Highway Construction. Fill shall be placed in 12-inch maximum lift thicknesses where heavy compaction equipment is to be used and 6-inch maximum uncompacted lift thicknesses where hand-operated equipment is used.

The geotextile shall be pretensioned during installation using either Method 1 or Method 2 as described herein. The method selected will depend on whether or not a mudwave

EXHIBIT 5 – SPECIAL PROVISIONS

forms during placement of the first one or two lifts. If a mudwave forms as fill is pushed onto the first layer of geotextile, Method 1 shall be used. Method 1 shall continue to be used until the mudwave ceases to form as fill is placed and spread. Once mudwave formation ceased, Method 2 shall be used until the uppermost geotextile layer is covered with a minimum of 1 foot of compacted fill. These special construction methods are not needed for fill construction above this level. If a mudwave does not form as fill is pushed onto the first layer of geotextile, then Method 2 shall be used initially and until the uppermost geotextile layer is covered with at least 1 foot of compacted fill.

Method 1

After the working platform, if needed, has been constructed, the first layer of geotextile shall be laid as outlined in the project plans and the joints sewn together. The geotextile shall be stretched manually to ensure that no wrinkles are present in the geotextile. The fill shall be end-dumped and spread from the edge of the geotextile. The fill shall first be placed along the outside edges of the geotextile to form access roads. These access roads will serve three purposes: to lock the edges of the geotextile to form access roads, to contain the mudwave, and to provide access as needed to place fill in the center of the embankment. These access roads shall be approximately 16 feet wide. The access roads at the edges of the geotextile shall have a minimum height of 2 feet completed. Once the access roads are approximately 50 feet in length, fill shall be kept ahead of the filling operation, and the access roads shall be kept approximately 50 feet ahead of this filling operation. Keeping the mudwave ahead of this filling operation and keeping the edges of the geotextile from moving by use of the access roads will effectively pre-tension the geotextile. The geotextile shall be laid out no more than 20 feet ahead of the end of the access roads at any time to prevent overstressing of the geotextile seams.

Method 2

After the working platform, if needed, has been constructed, the first layer of geotextile shall be laid and sewn as in Method 1. The first lift of material shall be spread from the edge of the geotextile, keeping the center of the advancing fill lift ahead of the outside edges of the lift. The geotextile shall be manually pulled taut prior to fill placement. Embankment construction shall continue in this manner for subsequent lifts until the uppermost geotextile layer is completely covered with 1 foot of compacted fill.

4.0 METHOD OF MEASUREMENT

Measurement of geotextile is on a square yard basis and will be computed based on the total area of geotextile shown in the plans, exclusive of the area of geotextiles used in any overlaps, seams, and/or joints. This shall include all costs associated with installation of the geotextile. Overlaps and any geotextile waste are an incidental item.

5.0 BASIS OF PAYMENT

Payment at the contract unit price is full compensation for all resources necessary to complete the item of work under the contract. Payment for the completed and accepted quantities is made under the following:

Item No.	Pay Item	Unit
2037110	GEOTEX REINF.	SY

(30) SECTION 205: MONITORING DEVICES – PIEZOMETER:

May 09, 2013

Supplemental Specification for Monitoring Devices – Piezometer is revised as follows:

Section 2 Paragraphs 2 and 3 shall be replaced with the following:

“Piezometer shall be installed from the working surface to the depths shown on the plans. These depths refer to the middle of the piezometer referenced to the original ground surface. Enough cable shall be provided to run from the pressure cell to the location of the Vibrating Wire Data Collection Center (VW-DCC) plus 10 feet for each instrument. The cable used to connect the pressure cell to the VW-DCC shall meet the requirements of the instrument manufacturer/supplier. The Contractor shall supply non-conductive conduit to encase the cable between the pressure cell and VW-DCC. The conduit shall have a minimal nominal diameter of 1 inch and meet the requirements of Schedule 80 materials. Provide enough conduit to enclose all lengths of buried cable from the pressure cells to the VW-DCC. All connects in the conduit and in the cable between the pressure cell and VW-DCC shall be water proof.

During roadway construction and any delay period for settlement, the piezometers will be read and analyzed by the Engineer at the same times outlined in the Special Provision for Settlement Plates. If the piezometers indicate excessive excess pore pressures at a given location during embankment placement operations, the placing of embankment material shall be suspended.”

The following shall be added to the end of Section 2 Paragraph 4:

“Figure 1 depicts the installation of a single piezometer in a borehole; however, multiple piezometers may be placed in the same borehole. The installation of multiple piezometers is not shown for clarity.”

Section 4 Paragraph1 shall be replaced with the following:

“Unit price bid for "Monitoring Devices-Piezometer" shall include all costs associated with supplying, installing, and maintaining the monitoring devices. The Contractor will monitor the devices throughout construction of the embankment and for up to a period of one year after the final delay period for settlement when embankment construction is completed. The Contractor will be responsible for ensuring the piezometers are in working order and accessible once the embankment is complete.”

(31) SECTION 205: SETTLEMENT PLATES:

May 09, 2013

1.0 GENERAL

1.1 Scope

The work under this Section consists of furnishing all supervision, labor, material, equipment, and related services necessary to furnish and install settlement plates as indicated on the Drawings and specified herein. The Contractor shall accommodate the Engineer in the monitoring of settlement plates.

The purpose of the settlement-monitoring program is to:

1. Confirm estimates of the time rate of settlement of embankments and retaining walls during construction so that construction methods may be adjusted, if necessary, to meet the project schedule;
2. Confirm that settlement is sufficiently completed prior to final grading and paving of roadways supported on embankments and retaining walls.

Consolidation settlement of the foundation soils is expected to occur during and for a period after construction of new embankments and retaining walls. The magnitude and

EXHIBIT 5 – SPECIAL PROVISIONS

rate of the settlement will depend on the variation of the stratigraphy and consolidation properties of the foundation soils. To effectively manage the post-construction settlement, settlement plates shall be used to monitor the magnitude and rate of settlement during construction.

Settlement plates shall be furnished and installed by the Contractor in the presence of the Engineer. Settlement plates shall consist of a steel plate with coupling for attaching the central rod and protective PVC casing. A benchmark shall be established on stable ground that is not subject to settlement.

1.2 Responsibilities of Contractor:

The Contractor shall notify the Engineer at least five (5) working days prior to the installation of settlement plates.

The Contractor shall furnish and install the settlement plates in the presence of the Engineer.

The Contractor shall provide a licensed surveyor to stake out and provide as-built locations and elevations of all settlement plate locations and benchmarks.

The Contractor shall protect the settlement plates and benchmarks from damage for the duration of the Contract.

The Contractor shall provide the Engineer safe access to the settlement plates for the purpose of data collection for the duration of the Contract.

The Contractor shall be responsible for locating all settlement plates in the field and ensuring that no conflicts exist between settlement plates and existing and proposed structures, utilities or other construction proposed or present at the site.

1.3 Site Preparation

The Contractor shall ensure a firm base on which heavy equipment and/or other necessary equipment can be operated safely under its own power for installation of settlement plates.

The Contractor shall accurately locate all settlement plates in accordance with Drawings. Settlement plates may be adjusted by the Contractor, with the approval of the Engineer, to avoid utilities, foundations, and all other underground construction.

1.4 Existing Soil Conditions:

The subsurface conditions encountered at the site are presented in the Contract Plans and documents.

2.0 PRODUCTS

2.1 Settlement Plate

The settlement plate shall consist of a 30-in. square, 1/2-in. thick steel plate with a coupling centered on the plate for attaching a central steel rod. In addition, the plate shall have a means for keeping the protective PVC casing centered on the steel rod.

2.2 Central Steel Rod

A central steel rod shall extend from the plate vertically to allow for measurements of the elevation of the settlement plate. The rod shall be of sufficient diameter to prevent buckling or swaying over the height of the fill. In addition, the rod will either be threaded at both ends or will be threaded rod to allow for the addition of extensions. The central steel rod will include the necessary couplers to allow for the extension. Metal pipe may

EXHIBIT 5 – SPECIAL PROVISIONS

be substituted for the rod, provided the pipe is manufactured from similar material as the settlement plate.

2.3 Protective PVC Casing

A schedule 40 PVC pipe shall be installed around the central steel rod to protect the rod from compaction operations. The PVC casing will have an inside diameter of no less than 3 inches. The casing may have either glued or threaded joints. The joints should form a watertight seal. A protective cap shall be placed at the top of the PVC casing to prevent soil, water and other debris from being introduced into the casing. In addition, the casing shall extend a minimum of 1 foot and no more than 5 feet above the ground surface at the base of casing during fill placement. Further, the contractor shall visibly identify the location of the PVC casing to prevent damage to the casing during the placement of fill materials.

2.4 Incidentals

Incidental hardware, fasteners, tools, and the like, as necessary to install the system in accordance with these specifications, shall be provided.

3.0 SUBMITTALS

The Contractor shall submit a plan for the settlement plates indicating where the coupling and protective casing supports are to be located and the method to be used to attach the coupling and casing supports.

Within 1 week following installation, the contractor shall submit an installation record for each settlement plate, which includes the plate designation, station, offset, and elevation of the Settlement plate. The settlement plate shall be located to an accuracy of 0.01 ft (both vertically and horizontally).

4.0 EXECUTION

4.1 Settlement Plate Installation

The Contractor shall furnish and install settlement plates in accordance with the Drawings and these specifications and in the presence of the Engineer. Settlement plates shall be installed prior to embankment or retaining wall construction and following installation of wick drains, stone columns, or other ground improvement, and grubbing and clearing in the immediate vicinity of each settlement plate. The Contractor, only with the approval of the Engineer, may adjust settlement plate locations. The settlement plates shall be placed on a firm, level area as indicated in the plans.

4.2 Allowance for Settlement Plate Monitoring

The Contractor shall accommodate the Engineer during construction to provide safe and timely access to settlement plates for the purpose of obtaining measurements, as construction progresses. The Contractor shall retain a licensed land surveyor to monitor the settlement of the plates. Evaluation of the settlement plate data will be the responsibility of the Engineer.

4.3 Fill Height Survey

The Contractor shall make a survey of the central rods daily while fill is being placed, and twice weekly after completion of fill placement, unless directed otherwise by the Engineer. Additionally, surveys shall be made at the addition of an extension rod. The measurements shall be obtained both before and after the addition of the extension rod. Surveys made by the Contractor shall be provided to the Engineer within one week. In addition, the Contractor shall provide all readings as the elevation of the plate to the nearest 0.01 ft. Further the Contractor will provide the temperature in degrees Fahrenheit (°F) and the time (actual) of obtaining the settlement plate elevations.

EXHIBIT 5 – SPECIAL PROVISIONS

4.4 Protection of Settlement Plates

The Contractor shall protect settlement plates from damage and vandalism for the duration of the Contract and repair or replace damaged or inoperative settlement plates at no cost to the Department.

4.5 Abandonment of Settlement Plates

Once the Engineer has determined that the settlement plates have served their purpose and are no longer needed, they shall be abandoned in-place. The Contractor shall remove as much of the central steel rod as can be recovered and shall cut the PVC casing off two feet beneath the finished subgrade. The Contractor shall fill the PVC casings remaining in the ground with lean grout and shall place two feet of properly compacted fill on top of the testing location.

5.0 METHOD OF MEASUREMENT

The number of settlement plates, as provided in the plans, will be paid for at the contract unit price bid for "Monitoring Device - Settlement Plates" which shall include all equipment, including but not limited to the settlement plates; mobilization; labor; surveys; materials; incidentals and abandonment required by these Specifications.

6.0 BASIS OF PAYMENT

The price and payment for this work shall be full compensation for furnishing the necessary Settlement Plates, including the settlement plates, surveys and incidental items based on the acceptance of the Settlement Plate installation by the Engineer.

Payments shall be made under:

Item No.	Pay Item	Pay Unit
2038110	MON. DEVICE – SETTLEMENT PLATE	EA

EXHIBIT 5 – SPECIAL PROVISIONS

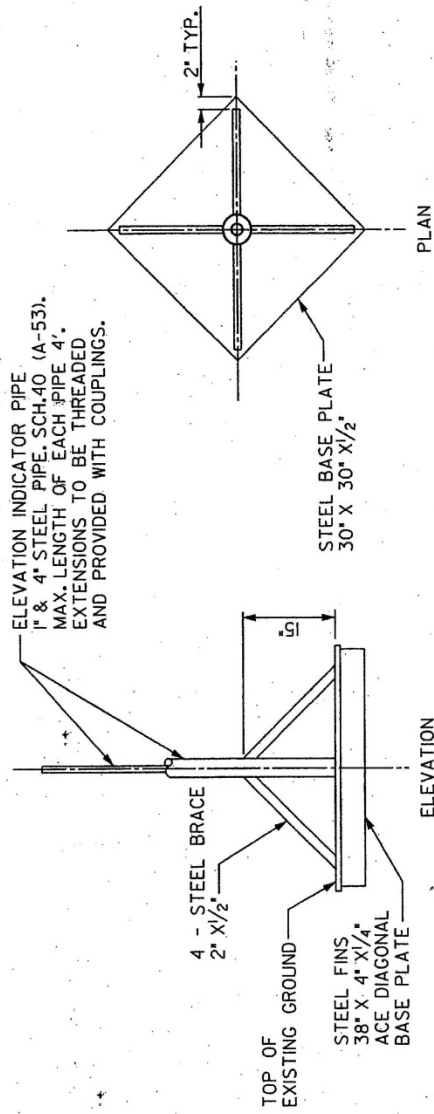

MONITORING DEVICE - SETTLEMENT PLATE DETAIL
NOT TO SCALE

(32) SECTION 208: GEOTEXTILES FOR SEPARATION AND STABILIZATION:

December 23, 2009

1.0 DESCRIPTION

This work is furnishing and installing geotextiles.

2.0 MATERIALS

A geotextile is defined as any permeable polymeric textile used with foundation, soil, rock, earth, or any other geotechnical engineering related material, as an integral part of a civil engineering project, structure, or system. Use geotextiles and thread used in joining geotextiles manufactured from fibers consisting of long-chain polymers, composed of at least 95 percent by weight of polyolefins or polyesters. Use geotextiles with fibers formed into a stable network such that the fibers or yarns retain their dimensional stability relative to each other, including selvages (edges) during shipping, handling, placement, and in service. Use geotextile free from defects or tears.

- A. **Minimum Average Roll Values.** All property values, with the exception of Apparent Opening Size (AOS), represent Minimum Average Roll Values (MARV) in the weakest principal direction. Provide geotextiles whose average test results from any roll sampled in a lot for conformance or quality assurance testing meets or exceeds minimum values provided in this Section.
- B. **Apparent Opening Size.** Values for Apparent Opening Size (AOS) represent maximum average roll values. Acceptance will be based on ASTM D 4759.
- C. **Separation Geotextile.** Use separation geotextile for unsaturated firm subgrade conditions.
- D. **Stabilization Geotextile.** Use stabilization geotextile for soft, wet, saturated subgrade conditions.

Furnish geotextiles meeting the strength property requirements of Table 1 and the AOS, permittivity, and ultraviolet stability requirements of Table 2 for separation geotextile, Table 3 for stabilization geotextile. The geotextile properties required for each class of survivability are dependent upon geotextile type, i.e. woven or nonwoven. When sewn seams are used, the strength of the sewn seams must be equal to or greater than 90 percent of the specified grab tensile strength.

TABLE 1 - GEOTEXTILE STRENGTH PROPERTY REQUIREMENTS

			GEOTEXTILE SURVIVABILITY ¹			
			Moderate Survivability (CBR ≥ 3; c _u ≥ 1,800 psf)		High Survivability (CBR < 3; c _u < 1,800 psf)	
PROPERTY	TEST METHODS	UNITS	Woven	Non-woven	Woven	Non-woven
Grab Elongation	ASTM D 4632	%	< 50	≥ 50	< 50	≥ 50
Grab Strength	ASTM D 4632	lbs.	250	160	315	200
Sewn Seam Strength ²	ASTM D 4632	lbs.	225	145	285	180
Tear Strength	ASTM D 4533	lbs.	90	55	110	80
Puncture Strength	ASTM D 4833	lbs.	90	55	110	80
Apparent Opening Size	ASTM D 4751	Sieve Size	Required property values for AOS, permittivity, and UV stability are based on the geotextile applications. Refer to Table 2 for separation geotextile, Table 3 for stabilization geotextile.			
Permittivity	ASTM D 4491	sec. ⁻¹				
Ultraviolet Stability (retained strength)	ASTM D 4355	%				

Notes:

1. All numeric values represent Minimum Average Roll Value (MARV) in the weaker principal direction.
2. When sewn seams are required. Refer to Section 3, Table 4 for overlap requirements.

2.1 Separation Geotextile.

Provide geotextile meeting the strength requirements from Table 1 for the level of survivability specified on the plans or in the special provisions. Provide geotextile meeting the permittivity, apparent opening size, and ultraviolet stability requirements of Table 2.

TABLE 2 - SEPARATION GEOTEXTILE PROPERTY REQUIREMENTS

	TEST METHODS	UNITS	REQUIREMENTS
Geotextile Survivability	As specified from Table 1		
Permittivity ¹	ASTM D 4491	sec. ⁻¹	≥ 0.02
Apparent Opening Size	ASTM D 4751	Sieve Size (mm)	#30 (≤ 0.60)
Ultraviolet Stability (Retained Strength)	ASTM D 4355	%	≥ 50 after 500 hrs. of exposure

Notes:

1. Minimum value. Permittivity of the geotextile must be greater than that required for the soil. Use greater value as specified on the plans or in the special provisions.

2.2 Stabilization Geotextile.

Do not use woven slit film geotextiles (i.e. geotextiles made from yarns of a flat, tape-like character). Provide geotextile meeting the strength requirements for high survivability from Table 1. Provide geotextile meeting the permittivity, apparent opening size, and ultraviolet stability requirements of Table 3.

TABLE 3 - STABILIZATION GEOTEXTILE PROPERTY REQUIREMENTS¹

	TEST METHODS	UNITS	REQUIREMENTS
Geotextile Survivability	High Survivability from Table 1		
Permittivity ²	ASTM D 4491	sec. ⁻¹	≥ 0.10
Apparent Opening Size	ASTM D 4751	Sieve Size (mm)	#40 (≤ 0.43)
Ultraviolet Stability (Retained Strength)	ASTM D 4355	%	≥ 50 after 500 hrs. of exposure

Notes:

1. Do not use woven slit film geotextiles.
2. Minimum value. Permittivity of the geotextile must be greater than that required for the soil. Use greater value as specified on the plans or in the special provisions.

2.3 Source Approval.

Submit the following information regarding each geotextile proposed for use:

- Manufacturer's name and current address;
- Full product name/number;
- Geosynthetic material and structure; and
- Proposed geotextile use(s).

Submit a sample to the RCE for evaluation. Product acceptance is determined by comparing the average test results of all specimens within a given sample to the Minimum Average Roll Values (MARV) listed in Table 1.

Install geotextiles only after the material has been tested and accepted. Replace all geotextiles installed prior to acceptance that do not meet specifications at Contractor's expense.

2.4 Sampling.

Cut a sample from the geotextile roll with the minimum dimensions of 4 feet by the full width of the roll beyond the first wrap. After the sample and the required information have been submitted to the RCE, allow 30 calendar days for evaluation.

2.5 Identification, Shipment and Storage.

Conform to ASTM D 4873, *Standard Guide for Identification, Storage, and Handling of Geotextiles*. Clearly label each roll of geotextile shipped to the project with the name and address of the manufacturer, full product name/number, quantity, and roll number. Submit a manufacturer's certificate of compliance signed by an authorized manufacturer's official. The certificate must attest that the geotextile meets all the Minimum Average Roll Value (MARV) requirements specified in Table 1 as evaluated under the manufacturer's quality control program.

The RCE will reject materials that are mislabeled or misrepresented. Wrap each roll with a material that protects the geotextile, including ends of the roll, from damage due to shipment, water, sunlight, and contaminants. Maintain the protective wrapping during

periods of shipment and storage. Do not damage the geotextile or wrapping when unloading or transferring from one location to another. Do not drag the rolls.

During storage, elevate geotextile rolls off the ground and adequately cover to protect them from the following:

- Site construction damage;
- Precipitation;
- Ultraviolet radiation including sunlight;
- Chemicals that are strong acids or strong bases;
- Flames including welding sparks, temperatures in excess of 140 °F (60 °C); and
- Mud, dirt, dust, debris and any other environmental condition that may damage the physical property values of the geotextile.

3.0 CONSTRUCTION REQUIREMENTS

3.1 General.

Prepare the surface on which the geotextile is to be placed so that no damage occurs to the geotextile. Do not drive construction equipment on the geotextile. Dispose of material with defects, rips, holes, flaws, deterioration, or other damage. Do not use defective material in the work.

If sewn seams are used for seaming the geotextile, use thread that consists of high strength polypropylene or polyester. Do not use nylon thread. Use thread that is of contrasting color to that of the geotextile itself.

For seams that are sewn in the field, provide at least a 10-foot length of sewn seam for sampling by the RCE before the geotextile is installed. For seams that are sewn in the factory, provide samples as directed and witnessed by the RCE at random from any roll of geotextile that is used on the project.

For seams that are field sewn, use the same equipment and procedures for both the sampling and production seams. If seams are to be sewn in both the machine and cross-machine direction, provide samples of seams from both directions.

Submit the seam assembly description along with the sample of the seam. Include in the description the seam type, stitch type, sewing thread, and stitch density.

1.2 Separation/Stabilization Geotextile.

Prepare the installation site by clearing, grubbing, and excavating or filling the area to the design grade. This includes removal of topsoil or vegetation. The RCE will identify soft spots and unsuitable areas during site preparation. Excavate these areas and backfill with approved granular material and compact as specified. Grade the area to be covered by the geotextile to a smooth, uniform condition, free from ruts, potholes, and protruding objects such as rocks or sticks.

Spread the geotextile immediately ahead of the covering operation. Lay the geotextile smooth without wrinkles or folds on the prepared subgrade in the direction of construction traffic. Remove wrinkles and folds by pulling the geotextile taut as required. Use soil piles or the manufacturer's recommended method (as approved by the RCE) to hold the geotextile in place until the specified cover material is placed. Overlap, sew or join adjacent geotextile rolls and roll ends as shown on the plans or as directed by the RCE. Overlap in the direction shown on the plans. Overlap in accordance with the requirements of Table 4, or as specified on the plans or in the special provisions.

EXHIBIT 5 – SPECIAL PROVISIONS

TABLE 4 - OVERLAP REQUIREMENTS

UNDRAINED SHEAR STRENGTH OF SUBGRADE	MINIMUM OVERLAP
> 2,000 psf	1 foot
500-2,000 psf	3 feet or Sewn
< 500 psf	Sewn
All roll ends	3 feet or Sewn

On curves, cut or fold the geotextile to conform to the curve. Fold or overlap in the direction of construction and hold in place using pins, staples, or piles of fill or rock.

Do not cover the geotextile until inspected for damage by the RCE. Repair or replace all damaged geotextile at Contractor's expense. Make repairs following the manufacturer's recommendation or use a patch of the same material placed over the damaged area, overlapped at least 3 feet from the edge of any part of the damage. Sewing repairs are an acceptable alternative.

Place fill over the geotextile by dumping onto previously placed material and pushing the material into place. Do not operate any construction equipment directly on the geotextile under any circumstances. Place the fill material in uniform layers so that there is the minimum specified lift thickness between the geotextile and equipment tires or tracks at all times. The minimum thickness of the first lift is 8 inches. Do not allow construction equipment to turn on the first lift of material above the geotextile. Do not blade the first lift placed over the geotextile. If the subgrade is very soft with an undrained shear strength less than 500 psf minimize pile heights to less than 3 feet and spread piles as soon as possible after dumping to minimize the potential for localized subgrade failure due to overloading of the subgrade.

Do not use sheepsfoot or studded compaction equipment on the first lift placed over the geotextile. Stop vibrator on compaction equipment if pumping occurs. Do not operate any construction equipment that results in rutting in excess of 3 inches on the first lift. If rutting exceeds 3 inches, decrease the construction equipment size and/or weight or increase the lift thickness. Use only rubber-tired rollers for compaction if any foundation failures occur when placing subsequent lifts. Compact all lifts to the moisture and density requirements for earth embankment specified in the Standard Construction Specifications. Do not blade material down to remove ruts. Fill any ruts or depressions with additional material and compact to the specified density.

4.0 METHOD OF MEASUREMENT

Geotextiles are measured by the square yard as staked by the RCE. Measurement excludes laps, seams, and joints.

5.0 BASIS OF PAYMENT

Payment at the contract unit price is full compensation for all resources necessary to complete the item of work under the contract. Payment for the completed and accepted quantities is made under the following:

<u>Pay Item</u>	<u>Pay Unit</u>
Geotextile, Separation/Stabilization	Square Yard

- (33) **SECTION 305: GRADED AGGREGATE BASE COURSE:**
Only one type of Graded Aggregate Base Course is to be selected. The Contractor is to indicate on the attached form on page **Error! Bookmark not defined.** which type has been selected for use on this project. This form is to be submitted to the Resident Construction Engineer at the Preconstruction Conference.
- (34) **SECTION 305: MAINTENANCE STONE:**
Maintenance Stone used on this project shall conform to the gradation requirements of Section 305, or to the gradation specified for Aggregate No. CR-14 in the Standard Specifications.
- (35) **SECTION 308: CEMENT STABILIZED AGGREGATE BASE:**
Reference is made to Supplemental Technical Specification SC-M-308 “Cement Stabilized Aggregate Base.” For the purposes of applying this Supplemental Technical Specification when applying pay factor adjustments for thickness tolerances, a unit price of **\$15 per square yard** will be used.
- (36) **SECTION 401: DRESSING OF SHOULDERS:**
Prior to the placement of asphalt mixtures on existing roadways, the contractor will be required to remove all vegetation adjacent to the edge of pavement which impedes the placement of the asphalt mixture to the specified width. The contractor shall also remove and dispose of all excess asphalt which is disturbed during minor grading for widening, or during removal of debris or grass from existing surface during preparation of surface for new lift. After the asphalt mixture has been placed, the contractor shall blade the disturbed material to the extent that the shoulder is left in a neat and presentable condition. All excess material shall be removed from the project. No direct payment shall be made for this work, all costs are to be included in the price of other items of work.
- (37) **SECTION 401: HOT MIX ASPHALT (HMA) QUALITY ASSURANCE:**
Reference is made to the Supplemental Technical Specification “Hot Mix Asphalt (HMA) Quality Assurance.” For the purposes of applying this Supplemental Technical Specification, there will be no pay factor adjustment greater than 100% for any given lot. When applying pay factor adjustments of less than 100%, a unit price of **\$75 per ton** will be used.
- (38) **SECTION 401: HOT-MIX ASPHALT RIDEABILITY:**
Reference is made to the Supplemental Technical Specification “Hot-Mix Asphalt Rideability.” For the purposes of applying this Supplemental Technical Specification, there will be no pay factor adjustment greater than 100%. When applying pay factor adjustments of less than 100%, price Adjustments will be calculated based on **\$75 per ton**.
- (39) **SECTION 401: ASPHALT BINDER ADJUSTMENT INDEX:**
Reference is made to the Supplemental Specification Dated **March 3, 2009** on SCDOT’s Internet Website: http://www.scdot.org/doing/road_SupSpec.aspx#2000 . The SCDOT will establish the Basic Bituminous Index and the unit price for liquid asphalt to be used for bituminous adjustments as the most recent Liquid Asphalt Cement Index shown on the SCDOT website: http://www.scdot.org/doing/constructionLetting_MonthlyIndex.aspx at the time the proposals are due.

The Contractor shall provide the SCDOT with a copy of each Daily Report of Asphalt Plant Inspection within 7 calendar days. These reports will be used to determine the amount of liquid asphalt placed each estimating period.

A price adjustment (negative or positive) will be applied each estimate period to the liquid asphalt binder as appropriate throughout the life of this contract. The following Section of the Supplemental Specification is hereby modified:

Additional Provisions:

- A. The Department will calculate and apply fuel adjustments to estimates based on index values set at the beginning of the estimate period.
 - o Estimate period begins on the 1st of the month and ends on the last day of the month. The 1st of the month Index will be compared to the contract Base Index to determine index adjustments for the estimate period.

(40) SECTION 401: SURFACE PLANING OF ASPHALT PAVEMENT:

1. GENERAL

1.1 Description:

This Special Provision replaces all references to Surface Planing of Asphalt Pavement in Subsection 401 of the Standard Specifications in their entirety. It does not replace or amend Subsection 611 of the Standard Specifications. It describes the material and construction requirements for the surfacing planing of existing asphaltic concrete pavement by micro-milling to remove wheel ruts and other surface irregularities, restore proper grade and/or transverse slope of pavement as indicated in the Plans or as instructed by the RCE. Ensure that the planed surface provides a texture suitable for use as a temporary riding surface or an overlay with OGFC with no further treatment or overlays. Do not use the planed surface as a temporary riding surface for more than ten days if no corrective action is required and no more than 21 days if corrective action is required unless otherwise instructed by the RCE.

1.2 Pay Factor Adjustments:

When applying pay factor adjustments for surface planing discussed in Sections 5.2 below a unit price of **\$2.00 per square yard** shall be used. For the purposes of applying the table in SC-M-502 Supplemental Technical Specification referenced in this special provision, there will be no pay factor adjustment greater than 100%.

2. REFERENCED DOCUMENTS

2.1 SCDOT Standard Specifications, Edition of 2007

2.2 SC-M-502, Rideability of PCC Pavement

3. EQUIPMENT

3.1 Provide power-driven, self-propelled micro-milling equipment that is the size and shape that allows traffic to pass safely through areas adjacent to the work. Also, use equipment with the following characteristics.

3.1.1 Ensure that the equipment is equipped with a cutting mandrel with carbide-tipped cutting teeth designed for micro-milling HMA and bituminous treated pavement to close tolerances.

3.1.2 Ensure that the equipment is equipped with grade and slope controls operating from a stringline or ski and based on mechanical or sonic operation.

3.1.3 Ensure that the equipment is capable of removing pavement to an accuracy of 0.0625 inches.

3.1.4 Ensure that the equipment is furnished with a lighting system for night work, as necessary.

3.1.5 Ensure that the equipment is provided with conveyors capable of transferring the milled material from the roadway to a truck located to the side, rear, or front while minimizing airborne dust and debris.

4. CONSTRUCTION REQUIREMENTS

- 4.1 Follow the Plans to micro-mill the designated areas and depths, including bridge decks, shoulder, and ramps, as required. Ensure that the following requirements are met.
- 4.1.1 Prior to commencement of the Work, construct a test section that is 1156 feet in length with a uniformly textured surface and cross section on the road to be treated as approved by the RCE. Ensure that the final pavement surface has a transverse pattern of 0.2 inches center to center of each strike area and the difference between the ridge and valley of the mat surface in the test section does not exceed 0.0625 inches.
- 4.1.2 Milling depth may range up to 2 inches as necessary to fully remove existing OGFC surface, which has a typical nominal depth of one inch, as well as lesser depths on shoulders to provide a planar surface that allows appropriate drainage prior to placement of new OGFC. While milling depths over one inch are anticipated to ensure OGFC removal in low spots as well as to meet rideability requirements, milling depth should be minimized when possible to avoid excessive removal of the pavement structure while still removing all existing OGFC.
- 4.1.3 The Department will test the test section for rideability following Subsection 6 of SC-M-502 for diamond ground and textured existing concrete pavement, except that the maximum acceptable rideability is 90 inches per mile for each 0.1 mile segment. The first and last 50 feet of the test section will not be included in the two 0.1 mile segments. Provide the RCE with at least three business days of notice prior to need of rideability testing.
- 4.2 If any of the requirements of Section 4.1 are not met, do no further work and provide a written plan of action to the RCE detailing what steps will be taken to improve operations. The RCE may require corrective action to the test section prior to acceptance or accept the test section as is. Once the plan has been approved by the RCE, construct a second test section at a different location from the first. If the second test section meets the requirements of Section 4.1 and is approved by the RCE, continuous milling may commence. If the second test section fails to meet the requirements of Section 4.1, continue to construct test 1156 foot sections until satisfactory results are achieved.
- 4.3 Once continuous operations commence, continue to produce a uniform finished surface and maintain a constant cross slope between extremities in each lane.
- 4.4 Provide positive drainage to prevent water accumulation on the micro-milled pavement as shown on the Plans or as directed by the RCE.
- 4.5 Bevel back the longitudinal vertical edges greater than one inch that are produced by the removal process and left exposed to traffic. Bevel back at least 1.5 inches for each one inch of material removed. Use an attached mold board or other approved method.
- 4.6 When removing material at ramp areas and ends of milled sections, the transverse edges may be temporarily tapered 10 feet to avoid creating a traffic hazard and to produce a smooth surface. However, ensure that a neat transverse joint is created prior to the placement of the OGFC; do not terminate OGFC by “pinching” the OGFC over a tapered area.
- 4.7 Remove dust, residue, and loose milled material from the micro-milled surface. Do not allow traffic on the milled surface and do not place overlying layers on the milled surface until removal is complete.

5. ACCEPTANCE

EXHIBIT 5 – SPECIAL PROVISIONS

- 5.1 Ensure that the micro-milling operation produces a uniform pavement texture that is true to line, grade, and cross section.
- 5.2 The Department will test and accept the milled surface for rideability as given in Subsections 6.2 through 6.4 of SC-M-502. The Adjusted Schedule of Payment given in Table 2 of Subsection 6 of SC-M-502 will apply to the contract unit price for the micro-milling as given in Subsection 6 of this special provision.
- 5.3 Micro-milled pavement surfaces are also subject to visual and straightedge inspections. Keep a 10-foot straightedge near the micro-milling operation to measure surface irregularities of the milled surface. Repair any areas exceeding 0.125 inches between the ridge and valley of the mat surface to the satisfaction of the RCE at no additional cost to the Department. Provide a written plan of action to the RCE for approval prior to performing any corrective action on the basis of rideability, grade, or surface texture.

6 MEASUREMENT AND PAYMENT

- 6.1 Measurement: The quantity measured for payment under this special provision is the number of square yards of micro-milled surface in place and accepted.
- 6.2 Basis of Payment: The quantity, as measured above, will be paid for at the contract unit price subject to the adjustments given herein, for which price and payment is full compensation for furnishing all materials, equipment, tools, labor, hauling, stockpiling, temporary asphalt, and any other incidentals necessary to satisfactorily complete the work. All reclaimed asphaltic pavement (RAP) becomes the property of the Contractor unless otherwise specified. No adjustment in the unit price for this item or other items will be considered for variations in the amount of RAP actually recovered.

Payment includes all direct and indirect costs and expenses required to complete the work. Payment will be made under:

Item No.	Pay Item	Unit
4013099	Surface Plane Asphalt Pavement, Variable	Square Yard

(41) SECTION 401: FULL DEPTH ASPHALT PAVEMENT PATCHING:

Description: The Contractor shall patch existing asphalt pavement at locations of high severity fatigue cracking and failed patches as directed by SCDOT. This work shall consist of the removal of deteriorated pavement and replacing with a 6 inch full depth asphalt plant mix patch.

Construction Process: The deteriorated pavement shall be removed to the width and length indicated by the RCE, with the face of the cut being straight and vertical. The pavement shall be removed to a depth of six (6) inches as directed by the RCE. In the event unstable material is encountered at this point, then such additional material shall be removed as directed by the RCE.

The volume of material removed below the patch shall be backfilled with crushed stone and thoroughly compacted in 4-inch layers with vibratory compactors. Prior to placing the asphalt patch material in the hole, the sides of the existing asphalt pavement shall be thoroughly tacked. The patch material shall then be placed in layers not exceeding 3 inches with each layer being thoroughly compacted with a vibratory compactor and pneumatic roller. The patch material shall be an approved SCDOT Asphalt Concrete Binder Course Mix. Patches shall be opened and filled in the same day. Asphalt mixture shall not be applied when the existing surface is wet or frozen. The finished patch shall be smooth riding. The patches are to be no less than six feet by six feet in size and should be spaced at not less than 25 feet between patches.

The quantity of full depth asphalt pavement patching to be paid for will be the actual number of square yards of existing asphalt pavement which has been patched and accepted. The work

EXHIBIT 5 – SPECIAL PROVISIONS

includes cleaning, removing, and disposing of debris from the patching work, furnishing and placement of crushed stone and asphalt patching material, and all other materials, labor, equipment, tools, supplies, transportation, and incidentals necessary to fulfill the requirements of this item of work.

The Contractor's bid shall include 1000 square yards of 6 inch full depth asphalt pavement patching. If more than the estimated square yards of patching are required by SCDOT, the Contractor will be paid a unit price of \$40.00 per square yard. If less than the estimated square yards of patching are required by SCDOT, the Contractor shall reimburse SCDOT for the quantity of full depth patching that was not needed. Reimbursement will be paid to SCDOT at a unit price of \$40.00 per square yard.

(42) SECTION 403: PAVING UNDER GUARDRAIL:

August 17, 2011

Section 403 is expanded as follows:

GENERAL:

Provide paving under guardrail as shown in the plans, in accordance with plan details and these special provisions. Pavement under guardrail shall only be placed where shown in the plans or as directed by the Engineer.

MATERIALS:

Pavement material under guardrail shall be the same as the hot mix asphaltic concrete surfacing being used on the adjacent roadway. Liquid asphalt binder shall be the same as that used for paving on the adjacent roadway.

Low-density Flowable Fill with a maximum 28-day compressive strength of 120PSI shall be used to fill leave out areas.

CONSTRUCTION:

Place hot mix asphaltic concrete surfacing under guardrail in accordance with Section 401 of the Standard Specifications where indicated on the plans or as directed by the Engineer. Refer to details provided in this special provision for typical limits of paving and requirements for leave out areas around guardrail posts.

Pave area between the edge of pavement and the face of the guardrail when that distance is less than 20 feet.

Extend paving under guardrail to bridge end at locations where concrete approach slabs are used.

When at least one opening between parallel lines of guardrail is less than 20 feet wide, pave the entire area between the lines of guardrail.

When openings between parallel lines of guardrail are more than 20 feet wide, but obstructions such as bridge columns reduce the access between the guardrail and the obstruction to less than 20 feet and/or the distance between any two obstructions is less than 20 feet then the area with any single point of access less than 20 feet wide shall be paved.

When areas around obstructions are paved, no area should remain unpaved that will sustain plant life.

EXHIBIT 5 – SPECIAL PROVISIONS

The top of pavement shall be constructed to be flush with surrounding earth shoulders and slopes.

Damage to pavement during subsequent construction, especially during driving of guardrail posts, should be minimized. Any damaged pavement must be restored to its original line and grade to the satisfaction of the Engineer.

Leave outs shown in the details shall be either formed or sawcut.

MEASUREMENT AND PAYMENT:

Hot mix asphalt surface course shall be measured and paid for in accordance with Section 401 of the Standard Specifications.

Liquid asphalt binder shall be measured and paid for in accordance with Section 401 of the Standard Specifications.

When additional excavation is required to obtain the depth of pavement specified, this additional excavation will be measured separately and paid for by the cubic yard as unclassified excavation in accordance with section 203 of the Standard Specifications.

When borrow is needed to construct the area to be paved to meet the typical section, this borrow excavation will be measured and paid for separately as borrow excavation in accordance with section 203 of the Standard Specifications.

The costs to provide the leave outs shall be considered incidental to the hot mix asphalt surface course and no separate measurement or payment shall be made for providing leave out areas.

Flowable fill for leave out areas will be measured and paid for in accordance with section 210 of the Standard Specifications.

Payment under this section will include the following:

Item No.	Pay Item	Unit
2031000	UNCLASSIFIED EXCAVATION	CY
2033000	BORROW EXCAVATION	CY
2103000	FLOWABLE FILL	CY
40110XX	LIQUID ASPHALT BINDER PG __-22	TON
40303XX	HOT MIX ASPHALT CONCRETE SURFACE COURSE TYPE _	TON

EXHIBIT 5 – SPECIAL PROVISIONS

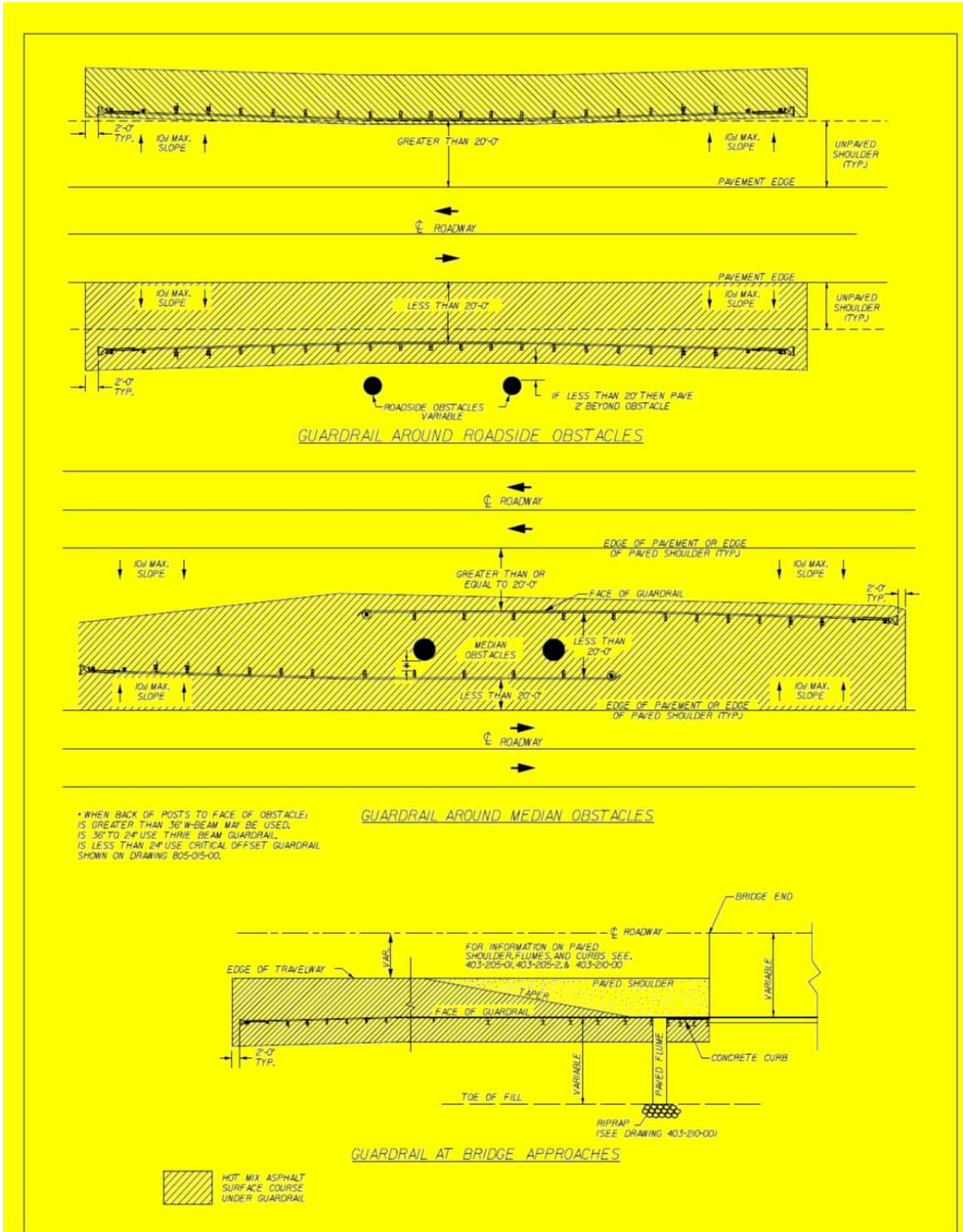
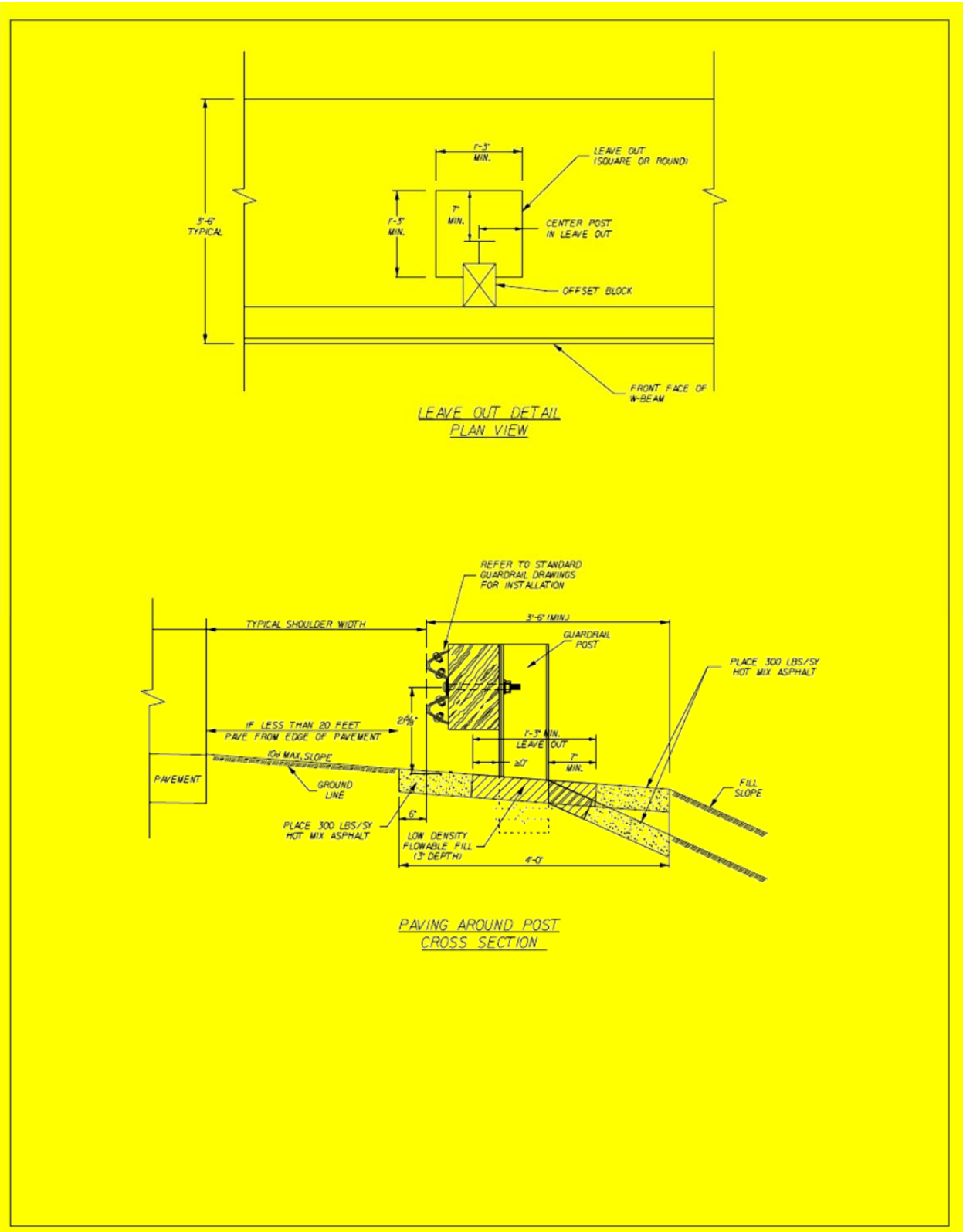

EXHIBIT 5 – SPECIAL PROVISIONS



(43) SECTION 501: ROLLER COMPACTED CONCRETE:

1. GENERAL

1.1 Description: Roller Compacted Concrete (RCC) consists of aggregate, portland cement and possibly other supplementary cementitious materials (fly ash, slag), and water. RCC is proportioned, mixed, placed, compacted, and cured in accordance with these specifications. Ensure that the RCC conforms to the lines, grades, thickness, and typical cross section shown in the plans or otherwise established by the RCE. When used as base course, it will be covered with one or more lifts of asphalt as shown on the Plans. Otherwise, the RCC will provide the final riding surface.

1.2 Pay Factor Adjustments: When applying pay factor adjustments for RCC thickness tolerances discussed in Sections 6.6.5 and 6.13 below a unit price of **\$40 per square yard** shall be used.

2. SUBMITTALS

2.1 Proposed RCC mix design: At least 45 days prior to the beginning of placing of RCC in the roadway, submit a proposed mix design to the State Materials Engineer at the SCDOT Office of Materials and Research for review. If the mix design appears satisfactory to the SCDOT, prepare and test a trial batch mixture at the Contractor's facilities to verify that the design criteria for strength are met. Perform batch mixture preparation and testing in the presence of representatives of the SCDOT Office of Materials and Research. Make no production until an approved mix design has been obtained.

3. MATERIALS

3.1 General: The RCE will approve all materials to be used for RCC construction based on laboratory tests or certifications of representative materials that will be used in the actual construction. All materials must conform to Section 700 of the *SCDOT Standard Specifications for Highway Construction*, unless otherwise modified herein.

3.2 Portland Cement, Fly Ash, and Water-Granulated Blast Furnace Slag: All cementitious material must conform to Section 501.2.1. Pozzolanic substitution for portland cement shall be allowed as specified in Section 701.4.9. If the use of silica fume is desired, have the type and usage pre-approved by the SCDOT State Materials Engineer.

3.3 Aggregates: Obtain all aggregates to be used from qualified sources appearing on the SCDOT Qualified Products Listing for aggregates. Use no aggregate where the plasticity index of the aggregate exceeds 5. Aggregates may be obtained from a single source or borrow pit, or may be a blend of fine and coarse aggregates. Use well-graded aggregate without gradation gaps and conforming to the following gradation:

Sieve Size	Percent Passing by Weight
1 inch	100
¾ inch	90-100
½ inch	70-100
3/8 inch	60-85
#4	40-60
#16	20-40
#100	6-18
#200	2-8

3.4 Water: Use only water conforming to Section 701.2.11 of the Standard Specifications.

3.5 Curing Compound: Where curing compounds are used, only those white-pigmented products shown in the current edition of SCDOT Qualified Products List 33 shall be used.

4. DESIGN STRENGTH

Use a mix design that demonstrates a compressive strength of 4000 psi within 28 days when specimens prepared according to ASTM C 1435 are tested according to AASHTO T 22. At least two sets of three cylinders will be produced, with one set being tested at 4 days and the other at 28 days. To determine the compressive strength for a set, two of the specimens will be tested. If the weaker of the two specimens is at least 90 percent of the strength of the stronger specimen, then the two values will be averaged to determine the overall compressive strength. If the weaker specimen has less than 90 percent of the strength of the stronger specimen, then the third specimen will be broken and all three specimens will be averaged. If one individual result is much lower or much higher than the other two due to defects in the specimen, that value may be discarded at the State Materials Engineer's discretion.

5. EQUIPMENT

5.1 General: Construct roller compacted concrete with any combination of equipment that will produce a completed pavement meeting the requirements for mixing, transporting, placing, compacting, finishing, and curing as provided in this specification.

5.2 Mixing Plant: Locate the mixing plant within a thirty-minute haul time from the point of RCC placement. Use only plants capable of producing an RCC pavement mixture in the proportions defined by the final approved mix design and within the specified tolerances. The capacity of the plant must be sufficient to produce a uniform mixture at a rate compatible with the placement equipment. If the plant is unable to produce material at a rate adequate to prevent unnecessary cold joints and frequent paver stoppages, the RCE may halt production until such time that a plant of appropriate capacity is used. Have the plant inspected and approved by the SCDOT Office of Materials and Research prior to production of material under these specifications.

5.2.1 Pugmill Plant: Use only pugmill plants of the central plant type with a twin-shaft pugmill mixer, capable of batch or continuous mixing, equipped with synchronized metering devices and feeders to maintain the correct proportions of aggregate, cement, pozzolan, and water. Other pugmill plant requirements are as follows:

5.2.1.1 *Aggregate Storage*: If previously blended aggregate is furnished, storage may be in a stockpile from which it is fed directly to a conveyor feeding the mixer. If aggregate is furnished in two size groups, follow proper stockpiling techniques to ensure aggregate separation.

5.2.1.2 *Aggregate Feed Rate*: Use aggregate bins with a feed rate controlled by a variable speed belt, or an operable gate calibrated to accurately deliver any specified quantity of material. If two aggregate size stockpile sources are used, the feed rate from each bin must be readily adjustable to change aggregate proportions, when required. Feed rate controls must maintain the established proportions of aggregate from each stockpile bin when the combined aggregate delivery is increased or decreased.

5.2.1.3 *Plant Scales*: Plant scales, if utilized, for any weigh box or hopper must comply with Section 701.3.2.

EXHIBIT 5 – SPECIAL PROVISIONS

- 5.2.1.4 *Cement and Pozzolan Material Storage:* Supply separate and independent storage silos for portland cement and pozzolan. At plants with two or more silos in which different types of cement or cementitious materials are stored, ensure that each silo has a sign at each fill inlet to reduce the potential for loading errors. Make the sign from a durable material, with minimum two-inch high by ¼-inch wide letters that are raised, indented, or cut. Ensure that the sign clearly identifies the material that is in the silo and may be easily read even when completely coated with dust. Flat signs with painted or applied letters are not acceptable.
- 5.2.1.5 *Preblended Portland Cement and Pozzolan:* If using preblended portland cement and pozzolan (such as fly ash or slag), employ blending equipment acceptable to the RCE and demonstrate, with a testing plan, the ability to successfully produce a uniform blended material meeting the mix design requirements. Perform testing on at least a daily basis to ensure both uniformity and proper quantities.
- 5.2.1.6 *Cement and Pozzolan Feed Unit:* Provide a satisfactory means of dispensing portland cement and pozzolan, volumetrically or by weight, to ensure a uniform and accurate quantity of cementitious material enters the mixer.
- 5.2.1.7 *Water Control Unit:* Use a water control unit capable of measuring the required amount of water for the approved mix by weight or volume. Ensure that the unit is equipped with an accurate metering device. Vary the amount of water to be used only with the approval of the RCE.
- 5.2.1.8 *Gob Hopper:* For continuous operating pugmills, provide a gob hopper attached to the end of the final discharge belt to temporarily hold the RCC discharge in order to allow the plant to operate continuously.
- 5.2.2 *Rotary Drum Mixer:* Provide a rotary drum batch mixer capable of producing a homogeneous mixture, uniform in color, and having all coarse aggregate coated with mortar. Equip the mixer with batching equipment to meet the following requirements:
- 5.2.2.1 *Weighing Equipment:* Measure the amounts of cement, pozzolan, and aggregate entering into each batch of RCC by direct weighing equipment. Use only weighing equipment that is readily adjustable in order to compensate for the moisture content of the aggregate or to change the proportionate batch weights. Include a visible dial or equally suitable device that will accurately register the scale load from zero to full capacity. The cement and pozzolan may be weighed separately or cumulatively in the same hopper on the same scale, provided the cement is weighed first.
- 5.2.2.2 *Weigh Hoppers:* Use only bulk cement and pozzolan weigh hoppers that are equipped with vibrators to operate automatically and continuously while weighing hoppers are being dumped. Ensure that the weigh hopper has sufficient capacity to hold not less than 10 percent in excess of the cementitious material required for one batch.

EXHIBIT 5 – SPECIAL PROVISIONS

5.2.2.3 *Water Metering:* Measure the amount of water entering each batch of RCC by weight or volume. Use only equipment capable of measuring the water to within a tolerance of plus or minus one percent and equipped with an accurate gauge or dial measuring device. Vary the amount of water to be used only with the approval of the RCE. During batching, admit water to the mixer only through the water measuring device and then only at the time of charging.

5.2.2.4 *Mixing Time:* Use only drum mixers equipped with an accurate clock or timing device, capable of being locked, for visibly indicating the time of mixing after all the materials, including the water, are in the mixer.

5.2.2.5 *Recharging:* Discharge all material in the drum before recharging. Ensure that the volume of mixed material per batch does not exceed the manufacturer's rated capacity of the mixer.

- 5.3 Paver: Place RCC with a high-density asphalt-type paver subject to approval by the RCE. Use only pavers equipped with compacting devices capable of producing an RCC pavement with a minimum of 90 percent of the maximum density in accordance with AASHTO T 180, Method D prior to any additional compaction. Ensure that the paver is of suitable weight and stability to spread and finish the RCC material, without segregation, to the required thickness, smoothness, surface texture, cross-section, and grade.
- 5.4 Compactors: Use self-propelled steel drum vibratory rollers having a minimum static weight of 10 tons for primary compaction. For final compaction, use either a steel drum roller, operated in a static mode, or a rubber-tired roller of equal or greater weight. Only use walk-behind vibratory rollers or plate tampers for compacting areas inaccessible to large rollers.
- 5.5 Haul Trucks: Use trucks for hauling the RCC material from the plant to the paver with covers available to protect the material from inclement weather. To ensure adequate and continuous supply of RCC material to the paver, have a sufficient number of trucks. If the number of trucks is inadequate to prevent frequent starts and stops of the paver, cease production until additional trucks are obtained.
- 5.6 Water Trucks: Keep at least one water truck, or other similar equipment, on-site and available for use throughout the paving and curing process. Equip such equipment with a spreader pipe containing fog spray nozzles capable of evenly applying a fine spray of water to the surface of the RCC without damaging the final surface.
- 5.7 Inspection of Equipment: Before start-up, the Contractor's equipment will be carefully inspected. Should any of the equipment fail to operate properly, cease work until the deficiencies are corrected.
- 5.8 Access for Inspection and Calibration: Provide the RCE or RCE's representative access at all times for any plant, equipment, or machinery to be used in order to check calibration, scales, controls, or operating adjustments.
6. CONSTRUCTION REQUIREMENTS
- 6.1 Preparation of Subgrade: Before the RCC processing begins, prepare the subgrade in accordance with Section 208 of the SCDOT Standard Specifications.
- 6.2 Quality Control Test Specimens: For each day's production, up to 1500 cubic yards of mix produced, prepare at least three sets of test specimens in accordance with ASTM C 1435 under the direct observation of the RCE or RCE's representative. A set of

EXHIBIT 5 – SPECIAL PROVISIONS

specimens consists of three cylinders. Make an additional three sets for each additional 1500 cubic yards or fraction thereof. Cure and transport the specimens to the Contractor's (or mix producer's) Office of Materials and Research-approved laboratory in accordance with ASTM C 31. Test two cylinders for compressive strength in accordance with ASTM C 39 at 3 days, 7 days, and 28 days under the direct observation of the RCE or RCE's representative. If the measured compressive strength between two cylinders varies by more than 10 percent of the stronger cylinder, test the third cylinder and average the results of the three cylinders. Otherwise, average the measured compressive strengths of the two cylinders tested at 28 days to determine the compressive strength of the lot. Retain the compressive strength test results for inspection by the RCE.

If the compressive strength measured at 3 days indicates that the 28-day compressive strength will be less than 3500 psi, investigate the potential causes of the low strengths and report to the RCE within 24 hours. If the compressive strength measured at 3 days indicates 28-day compressive strengths less than 3200 psi, immediately stop production and notify the RCE. Do not resume production until the cause of the discrepancy has been determined to the satisfaction of the RCE. The RCE may adjust compressive strength targets at 3 days as production continues based on field experience.

6.3 Mixing Process: Use the same mixture for the entire project unless otherwise stated in the project documents. If, during production, the source of portland cement, pozzolan, or aggregates is changed, then suspend production and submit a new mix design to the RCE for approval. Do not exceed the manufacturer's rated capacity for dry concrete mixtures in the mixing chamber. Keep the sides of the mixer and mixer blades free of hardened RCC or other buildups. Routinely check mixer blades for wear and replace if wear is sufficient to cause inadequate mixing.

6.3.1 *Mixing Time*: Use a mixing time adequate to ensure a thorough and complete mixing of all materials. Do not allow the mixing time, after all materials including water are in the mixer, to be less than 1½ minutes for one cubic yard and 20 seconds for each additional cubic yard.

6.3.2 *Mixture Ingredient Tolerances*: Ensure that the mixing plant receives the quantities of individual ingredients to within the following tolerances:

Material	Variation by Weight
Cementitious Material	±2.0%
Water	±3.0%
Aggregates	±4.0%

6.3.3 *Plant Calibration*: Prior to commencement of RCC production, carry out a complete and comprehensive calibration of the plant in accordance with the manufacturer's recommended practice. Provide all scales, containers, and other items necessary to complete the calibration. After completion of the initial calibration, calibrate the plant periodically as directed by the RCE. Plants listed on SCDOT Qualified Product List 28 at the time of RCC production are exempt from this requirement, although the SCDOT reserves the right to require additional calibration if variation in mixture quantities are suspected.

6.3.4 *Daily Reports*: Supply daily plant records of production and quantities of materials used that day to the RCE. These records may be used as a check on plant calibration.

6.4 Transportation: Transport the RCC pavement material from the plant to the areas to be paved in dump trucks equipped with retractable protective covers for protection from rain

or excessive evaporation. Ensure that the trucks are dumped clean with no buildup or hanging of RCC material in the corners. Have the dump trucks deposit the RCC material directly into the hopper of the paver or into a secondary material distribution system that deposits the material into the paver hopper. Dump truck delivery must be timed and scheduled so that RCC material is spread and compacted within the specified time limits.

6.5 Placing:

6.5.1 *Subbase Condition:* Prior to RCC placement, ensure that the surface of the subbase is clean and free of foreign material, ponded water, and frost. Ensure that the subbase is uniformly moist at the time of RCC placement. If sprinkling of water is required to remoisten certain areas, ensure that the method of sprinkling will not form mud or pools of freestanding water. Correct soft or yielding subbase areas prior to placement of RCC as specified in Section 6.1 above.

6.5.2 *Weather Conditions:*

6.5.2.1 *Cold Weather Precautions:* Employ cold weather precautions as detailed in Section 501.4.6 of the Standard Specifications.

6.5.2.2 *Hot Weather Precautions:* During periods of hot weather or windy conditions, take special precautions to minimize moisture loss due to evaporation. Cooling of aggregate stockpiles by shading or the use of a fine mist may be required. Protective covers may be required on dump trucks. Keep the surface of the newly placed RCC pavement continuously moist.

6.5.2.3 *Rain Limitations:* Conduct no placement of RCC pavement during rain conditions sufficient to be detrimental to the finished product. Placement may continue during light rain or mists provided the surface of the RCC pavement is not eroded or damaged in any way. Use dump truck covers during these periods. The RCE may terminate paving at any time when, in the RCE's judgement, the rain is detrimental to the finished product.

6.5.3 *Paver Requirements:* Place all RCC with an approved paver as specified in Section 5.3 and also meet the following requirements:

6.5.3.1 *Filling the Paver:* Do not allow the quantity of RCC material in the paver to approach empty between loads. Maintain the material above the auger at all times during paving.

Stopping the Paver: Ensure that the paver proceeds in a steady, continuous operation with minimal starts and stops, except to begin a new lane. Maximum paver speed during laydown is 10 feet per minute. Higher paver speeds may be allowed at the discretion of the RCE if the higher speeds may be obtained without distress to the final product or cause additional starts and stops.

6.5.3.2 *Surface Condition:* Ensure that the surface of the RCC pavement is smooth, uniform, and continuous without excessive tears, ridges, or aggregate segregation once it leaves the paver.

EXHIBIT 5 – SPECIAL PROVISIONS

- 6.5.4 *Inaccessible Areas*: Pave all areas inaccessible to either roller or paver with cast-in-place concrete meeting the compressive strength requirements of these specifications.
- 6.5.5 *Adjacent Lane Pavement*: Place adjacent paving lanes within 60 minutes. If more than 60 minutes elapses between placement of adjacent lanes, the vertical joint must be considered a cold joint and prepared in accordance with Section 6.7 below. At the discretion of the RCE, this time may be increased or decreased depending on ambient conditions of temperature, wind, and humidity. Multiple pavers may be used in tandem to reduce the occurrence of cold joints.
- 6.5.6 *Hand Spreading*: Broadcasting or fanning the RCC material across areas being compacted is not permissible. Such additions of materials may only be done immediately behind the paver and before any compaction has taken place. Any segregated coarse aggregate shall be removed from the surface before rolling.
- 6.5.7 *Segregation*: If segregation occurs in the RCC during paving operations, placement shall cease until the cause is determined and corrected to the satisfaction of the RCE. If the segregation is judged by the RCE to be severe, remove and replace the segregated area at no additional cost to the Department.

6.6 Compaction:

- 6.6.1 *Time to Compaction Start*: Ensure that compaction begins with the placement process and is completed within 60 minutes of the start of the mixing at the plant. The time may be increased or decreased at the discretion of the RCE depending on ambient conditions of temperature and humidity. Do not permit delays in rolling unless approved by the RCE. Plan operations and supply sufficient equipment to ensure that these criteria are met.
- 6.6.2 *Rolling*: Determine the sequence and number of passes by vibratory and non-vibratory rollers to obtain the specified density and surface finish. Only operate rollers in the vibratory mode while in motion. Rubber-tire rollers may be used for final compaction. Use additional rollers if specific density requirements are not obtained or if placing operations get ahead of the rolling operations.
- 6.6.3 *Rolling Longitudinal and Transverse Joints*: Do not operate the roller within 2 feet of the edge of a freshly placed lane until the adjacent lane is placed. Then, roll both edges of the two lanes together within the allowable time. If a cold joint is planned, then roll the complete lane and follow cold joint procedures as specified in Section 6.7 below.
- 6.6.4 *Inaccessible Areas*: Compact areas inaccessible to large rollers using walk-behind rollers or hand tampers.
- 6.6.5 *Density Requirements*: Field density tests will be performed in accordance with SC-T-33 as soon as possible, but no later than 30 minutes after the completion of the rolling. Only wet density is used for evaluation. The required minimum density is 98 percent of the maximum laboratory density obtained according to AASHTO T 180 (Method D). The in-place density and moisture content may be determined with a nuclear moisture-density gauge. The gauge will be calibrated for moisture content at the beginning of the work and at any time during the work. RCC properly placed and compacted, but not meeting the density requirements, shall be cored and tested at the Contractor's expense. If the tested area achieves 28-day design strength, it will be paid at the full unit price. If the tested area indicates

EXHIBIT 5 – SPECIAL PROVISIONS

strength less than 3500 psi but greater than 3150 psi, payment will be made as follows:

Compressive Strength (psi)	Price Reduction (Percent of Unit Bid Price)
3300-3499	5
3150-3299	15

If the cores indicate strengths less than 3150 psi at 28 days or longer, the Department will evaluate the results and may reject the affected area and require removal and replacement or elect to pay at a reduced rate.

6.7 Joints:

6.7.1 Fresh Vertical Joints: A joint is considered a fresh joint when an adjacent RCC lane is placed within 60 minutes of placing the previous lane or as specified by the RCE based on ambient conditions. Fresh joints do not require special treatment.

6.7.2 Cold Vertical Joints: Any planned or unplanned construction joints that do not qualify as fresh joints are considered cold joints. Prior to placing fresh RCC mixture against a compacted cold vertical joint, thoroughly clean the cold joint of loose or foreign material. Wet the vertical joint face and maintain it in a moist condition immediately prior to placement of the adjacent lane.

6.7.2.1 Sawing Cold Vertical Joints: For uncompacted surfaces or slopes more than 15 degrees from the vertical, cut the joint vertically for the full depth. Within 2 hours of final compaction, the edge of a cold joint may be cut with approved mechanical equipment. For edges cut after 2 hours, sawcut to the full depth of the pavement. Demonstrate any modification or substitution of the sawcutting procedure to the RCE for approval prior to use. In no case allow cutting of the edge to cause raveling or tearing of the surface. Moisten the cut edge immediately prior to placement of the adjacent lane.

6.7.3 RCC Pavement Joints at Structures: Line structures such as manholes, valves, or concrete curb and gutter with joint filler as defined in Section 501.2.6.1 of the Standard Specifications.

6.7.4 Control Joints: Construct transverse contraction joints at regular intervals up to 20-feet in the RCC pavement to induce cracking at pre-selected locations unless otherwise indicated on the Plans or as directed by the RCE. At the option of the Contractor, soft-cut or green-cut saws may be utilized as soon as possible behind the rolling operation and set to manufacturer's recommendations. Conventional cut saws must be used as soon as the sawing operation will not result in raveling or other damage to the RCC pavement, but not more than 18 hours after RCC placement. Cut all joints to 1/4 the depth of the RCC pavement to a single saw blade width.

6.8 Finishing:

Ensure that the finished surface of the RCC pavement, when tested with a 10-foot straightedge or crown surface template, does not vary from the straightedge or template by more than 1/4 inch at any one point and shall be within 5/8 inch of the specified finished grade. When surface irregularities are outside these tolerances, diamond-grind the surface to meet the tolerance at no additional cost to the SCDOT.

6.9 Curing:

Immediately after final rolling and compaction testing, keep the surface of the RCC pavement continuously moist until an approved curing compound, a suitable prime coat, or a layer of asphalt concrete is applied.

6.9.1 *Water Cure:* Apply water cure by water trucks equipped with fog spray nozzles, soaking hoses, sprinkling system, or other means such that a uniform moist condition on the surface of the RCC is ensured. Apply this moisture in a manner that will not erode or damage the surface of the finished RCC pavement.

6.9.2 *Curing Compound:* Do not use curing compounds when the RCC material is to be promptly covered with asphalt. Apply curing compound as indicated in Section 501.4.11 of the Standard Specifications, except that the minimum rate of curing compound application is 0.09 gallons per square yard (11 square yards per gallon) unless a higher rate is specified by the curing compound manufacturer.

6.10 *Traffic:* Protect the RCC from vehicular traffic during the curing period. Completed portions of the RCC pavement may be opened to automotive and light truck traffic as soon as the strength is sufficient to prevent damage to the RCC. The pavement may be opened to unrestricted traffic after 4 days. If the temperature drops below 40° F, then the period of time the temperature is below 40° F will be added to the minimum time to opening.

6.11 *Maintenance:* Maintain the RCC pavement in good condition until all work is completed and accepted. Perform such maintenance at no additional cost to the SCDOT.

6.12 *Thickness:* Provide and operate equipment capable of extracting a small (approximately 1 inch diameter or greater) core to determine the pavement thickness. Extract samples in the presence of the RCE or RCE's representative unless otherwise directed .

6.13 *Thickness Tolerance -* The thickness of the completed RCC is measured at staggered intervals not to exceed 250 feet in length for two-lane roads. Measure the core to the nearest 1/8 inch at three different, evenly spaced locations and record the average. Where the RCC is deficient by more than 1/2 inch, correct such areas by removal and replacement. Where the measured thickness is more than 1/2 inch thicker than shown on the Plans, it is considered as the specified thickness, plus 1/2 inch. The average job thickness is the average of the depth measurements determined as specified above. Should this average thickness be more than 1/4 inch below the specified thickness, an adjusted unit price is used in calculating payment. This adjusted contract unit price bears the same ratio to the contract unit price as the square of the average thickness bears to the square of the specified thickness. When the contract includes more than one road, each road is considered separately.

7. MEASUREMENT AND PAYMENT

7.1 *Measurement:* The quantity measured for payment under this supplemental specification is the number of square yards of RCC Pavement completed and accepted, and measured in place along the surface of normal width of through-lane pavement. Pavement constructed outside the area designated to be paved will be disregarded in computing the number of square yards. Construction of control joints will not be measured separately and no direct payment will be made for this work.

EXHIBIT 5 – SPECIAL PROVISIONS

7.2 Basis of Payment: The quantity, as measured above, will be paid for at the contract unit price for RCC Pavement, of the thickness specified, which price and payment will be full compensation for furnishing all materials, equipment, tools, labor, and incidentals necessary to satisfactorily complete the work. Pavement that is deficient in thickness, but is permitted to be left in place, will be paid at the reduced unit price as provided in Section 6.13. No compensation will be allowed for the materials or labor involved in the removal of defective material.

Payment includes all direct and indirect costs and expenses required to complete the work. Payment will be made under:

Item Number	Description	Unit
5010100	ROLLER COMPACTED CONCRETE PAVEMENT	SY

(44) SECTION 502: FULL DEPTH CONCRETE PAVEMENT PATCHING:

Description: The Contractor shall patch existing concrete pavement at locations of high severity scaling, cracking and punchouts as directed by SCDOT. This work shall consist of the removal of deteriorated pavement and replacing with a 9 inch full depth Portland Cement Concrete Pavement.

Construction Process: The deteriorated pavement shall be removed to the width and length indicated by the RCE, with the face of the cut being straight and vertical. The pavement shall be removed to a depth of nine (9) inches as directed by the RCE. In the event unstable material is encountered at this point, then such additional material shall be removed as directed by the RCE.

The volume of material removed below the patch shall be backfilled with crushed stone and thoroughly compacted in 4-inch layers with vibratory compactors. Patching shall be performed in accordance with Section 502 of the Standard Specifications and the Concrete Pavement Patching Drawings in Attachment B. The finished patch shall be smooth riding.

The quantity of full depth concrete pavement patching to be paid for will be the actual number of square yards of existing concrete pavement which has been patched and accepted. The Contractor's bid shall include 2000 square yards of 9 inch full depth concrete pavement patching. If more than the estimated square yards of patching are required by SCDOT, the Contractor will be paid a unit price of \$105.00 per square yard. If less than the estimated square yards of patching are required by SCDOT, the Contractor shall reimburse SCDOT for the quantity of full depth patching that was not needed. Reimbursement will be paid to SCDOT at a unit price of \$105.00 per square yard.

(45) DIVISION 600: TRAFFIC SIGNALS

1. LIST OF TRAFFIC SIGNALS WITHIN PROJECT

Intersection No.	Intersection Name	Description of Signal
	I-77 SB @ US 1 (Two Notch)	Maintain detection at all times
	I-77 NB @ US 1 (Two Notch)	Maintain detection at all times
	I-77 SB @ SC 555 (Farrow Rd)	Maintain detection at all times
	I-77 NB @ SC 555 (Farrow Rd)	Maintain detection at all times
	I-77 NB @ S-52 (Killian Rd)	Maintain detection at all times
	I-77 SB @ S-52 (Killian Rd)	Maintain detection at all times

2. PROJECT DESCRIPTION

During rehabilitation of the ramps along this project it is anticipated there will be impacts associated to the detection at the traffic signals listed above. It is unacceptable for these traffic signals to operate in a pre-timed manner during the construction project. Therefore, the project should include any temporary detection measures (such as video detection cameras) that would be needed if damage to the existing inductive loops occurs during this project. In addition, once the rehabilitation is completed, the inductive loops should be replaced in accordance with the latest SCDOT design standards for stop bar loops.

In addition to maintaining the detection, any work at the ramps that impacts the traffic signal, such as damage to fiber interconnect or any other signal appurtenances shall be immediately repaired/replaced. Coordination with the District 1 Signal Staff should occur to ensure the work will avoid damaging traffic signal utilities, as much as is feasible.

The intersections involved are shown on the above "List of Traffic Signals within Project".

All signal work shall be inspected by the District Signal Shop. Any modifications to the signal work shall be approved by the District Traffic Engineer.

Include the District Signal Shop in all Preconstruction conferences.

Provide a redline signal plan to the District Signal Shop after the signal work is completed.

Full Continuity of Operation shall be provided; and shall include the installation of a temporary controller, if needed. Operation shall be transferred to the temporary controller, simultaneously turning off the old controller.

Below is more information concerning any changes, revisions, or clarifications to the SCDOT Traffic Signal Supplemental Specifications and/or pay items for this particular contract:

Mobilization: 103.1 Mobilization, 103.2 Mobilization of Material

No changes, revisions, or clarifications.

Wiring: 675.1 Electrical Conduit, 677.1 Electrical Cable, 680.2 Splice Box/Junction Box, 680.1 Electric Service

No changes, revisions, or clarifications.

Communications: 676.1 Fiber Optic Training, 676.2 Fiber Optic Test Equipment, 677.2 Communication Cable, 677.3 Fiber Optic Cable, 677.4 Fiber Interconnect Center, 677.5 Fiber Optic Modem, 677.6 Factory Terminated Patch Panel, 677.7 Spread Spectrum Radio Assembly

No changes, revisions, or clarifications.

Detection: 678.1 Detector Loop, 688.3 Video Detection – Loop Emulation System

Provide video detection cameras as necessary for temporary detection during rehabilitation. These cameras will become SCDOT property and may remain in place at the discretion of the District Traffic Engineer in addition to the inductive loops. Replace any damaged inductive loops and reconnect to traffic signal.

EXHIBIT 5 – SPECIAL PROVISIONS

Signal Supports: 682.1 Wood Pole, 682.2 Back Guy, 682.3 Steel Cable, 688.5 Steel Strain Pole and Foundation, 688.6 Concrete Strain Pole, 690.1 Steel Pole with Mast-Arm

No changes, revisions, or clarifications.

Signal Heads, Pedestrian Treatments, Illuminated signs, solar flashing assemblies: 682.4 Pedestrian Pole and Base, 686.1 LED Modules and/or Polycarbonate Vehicle Signal Head and/or Backplate, 686.2 Optically Programmable Vehicle Signal Head, 686.3 Pedestrian Signal Head, 686.4 Pedestrian Push Button Station Assembly with Sign, 686.5 Symbolic LED Blankout Sign, 688.9 Solar Powered Flasher Assembly

No changes, revisions, or clarifications.

Cabinet Items: 688.7 Controller and 332/336 Cabinet, 688.8 Remote Splice/Flasher Cabinet

No changes, revisions, or clarifications.

Service Items: 688.1 Removal Salvage and Disposal of Equipment and Materials, 688.2 Temporary Adjustment of Traffic Signal Equipment and Timings, 689.2 System Integration and Testing, 689.3 Traffic Signal System Training

No changes, revisions, or clarifications.

3. QUANTITY LISTS

No quantities are provided in a design build project.

4. EQUIPMENT

- a. SCDOT Supplied Equipment - The Department will not furnish signal equipment.
- b. Contractor Supplied Equipment
 - i. The CONTRACTOR shall furnish all **new** equipment (submittal of invoices required), including incidental items; used, refurbished equipment or any equipment past warranty will not be accepted.
 - ii. Compatibility
 1. To insure compatibility, any additional equipment required during the life of this contract, as Change Order or Extra Work, shall be purchased by the CONTRACTOR from the same Manufacturer as the original item.
 2. When installing equipment such as signal heads or pedestrian equipment, where some existing equipment is being retained, the contractor shall provide the same type of equipment, as is remaining, for visual compatibility.
 - iii. The CONTRACTOR shall submit for approval a list of equipment including make, model number, manufacturer serial numbers, and warranty information, in a format similar to chart on next page. The chart shows a list of potential furnished signal equipment. Documentation only has to be submitted for the furnish items required for this contract. At the time of such submission, the CONTRACTOR shall provide a copy of the Transmittal Letter, to the Engineer.
 - iv. If equipment is on the SCDOT Equipment Contract or the SCDOT QPL, catalog cut sheets do not have to be provided. On all other equipment, the CONTRACTOR shall submit for approval, catalog descriptions and documentation--THREE (3) COPIES--for each class of

EXHIBIT 5 – SPECIAL PROVISIONS

signal equipment and materials furnished by the CONTRACTOR. They are to be submitted TWO WEEKS PRIOR TO INSTALLATION to the Construction Office FOR APPROVAL. At the time of such submission, the CONTRACTOR shall provide a copy of the Transmittal Letter, to the Engineer.

- v. Equipment substitutions in the life of the contract are only allowed if the contractor can show a valid hardship in remaining with the originally submitted equipment. A valid hardship may include drastic price increases, non-availability of type of equipment due to unforeseen delivery or material shortages (contractor ordering equipment late does not apply), vendor going out of business, etcetera. SCDOT may allow equipment substitutions if product is of better quality than originally submitted or if contractor is replacing non-QPL items with QPL or SCDOT Equipment Contract items, or if equipment is experimental in nature and SCDOT wants to test said equipment.
- vi. SCDOT will not pay for furnish and or installation costs of any materials installed without prior approval and acceptance, in accordance with iii and iv above.
- vii. Contractor to provide letter from the manufacturer of the cabinet and from the manufacturer of the controller indicating the equipment provided is the SCDOT QPL qualified equipment; Contractor to ensure all warranties, serial numbers, documentation, and receipts are provided with cabinet assembly and controller delivery.

Item	Make	Model #	Manufacturer	Is item on current QPL or is item under current SCDOT equipment contract (y or n)	If no, is cut sheet attached (y or n)	Serial #'s attached	Warranty info attached	Purchase date	Purchase invoice attached
Traffic Signal Cabinet									
Traffic Signal Controller									
Conflict Monitor									
Electrical Cable									
Communication Cable									
Fiber Optic Cable									
Fiber Interconnect Center / Fiber Splice Trays									
Loop Wire and Sealant Splice Boxes / Junction Boxes									
Steel Cable									
Vehicle Signal Head with LED Modules									
LED Blank Out Signs									
Optically Programmable Vehicle Signal Head									
Pedestrian Signal Head									
Pedestrian Push Button Station Assembly									
Steel Strain Pole									
Mast Arm									
Concrete Strain Pole									
Controllers and 332/336 Cabinets									
Spread Spectrum Radio Assembly									
Ethernet Extender									
Video Detection Systems									

5. SIGNAL INTEGRATION

Signal integration is not anticipated to be needed for this project. If damage to a cabinet occurs and a new cabinet/controller is required, integration would be the responsibility of the design build team, in accordance with 689.2 System Integration and Testing.

6. GENERAL PROVISIONS

- a. All work under this Contract shall be performed under: the SOUTH CAROLINA DEPARTMENT OF TRANSPORTATION, "STANDARD SPECIFICATIONS FOR HIGHWAY CONSTRUCTION", Latest Edition; the SCDOT SUPPLEMENTAL SPECIFICATIONS FOR TRAFFIC SIGNALS; the SCDOT STANDARD DRAWINGS; these SCDOT TRAFFIC SIGNAL SPECIAL PROVISIONS; the "MANUAL ON UNIFORM TRAFFIC CONTROL DEVICES FOR STREETS AND HIGHWAYS" (latest revision); the SCDOT TRAFFIC SIGNAL DESIGN GUIDELINES; and the PLANS.
- b. Unless noted otherwise on the plans or in these Special Provisions this is a "turn-key" project, with the contractor furnishing and installing all equipment, complete and operational to the satisfaction of the Engineer.
- c. The PLANS are schematic in nature, showing what is generally expected at each intersection. The CONTRACTOR must devise/refine the final details, working within the Supplemental Specifications, the Design Details, the Standards, and with the Engineer.
- d. Any deviation from the Plans must be approved by the Engineer.
- e. At Project completion all traffic signals/equipment shall be complete and operational, to the satisfaction of the Engineer.
- f. The CONTRACTOR will install the traffic signal to provide a completely modern installation.
- g. Notifications
Prior to beginning construction, the CONTRACTOR shall participate in a "Pre-Construction Conference" at a time and place to be scheduled by the Department's Resident Construction Engineer (RCE).
- h. Unauthorized Work
Any work performed without notification of the proper parties in the Department, will be treated as un- authorized work (see Section 105.11 of the Standard Specifications), and could result in nonpayment to the CONTRACTOR for that work.
- i. Power
The CONTRACTOR, prior to the beginning of any construction activity, shall coordinate as necessary with the Utility Company supplying the power for this project. A representative of the Utility Company should be present at the RCE's Pre-Construction Conference.
- j. Maintenance during construction
The design build team shall be responsible for the maintenance and operation of all existing signals, from notice to proceed until the final acceptance of the project. Final acceptance occurs 60 days after all punch list items are completed and signal is accepted by SCDOT. This shall include all daily maintenance of signals and any emergencies which may arise. There is no separate pay item for maintenance during construction; maintenance is simply part of the construction process. Additional details on maintenance responsibility are found in these Special Provisions, *Section 10 Maintenance of Operations* and in the *SCDOT Traffic Signal Supplemental Specifications, 688.2 Temporary Adjustment of Traffic Signal Equipment and Timings*.

7. PERMITS, CODES, LICENSES, & ABILITIES

- a. All work shall be done in a workmanlike manner to meet the highest industry standards, all in accordance with the requirements of the latest editions of the National Electrical Code (NEC), the National Electrical Safety Code (NESC), the Illuminating Engineering Society (IES), the American National Standards Institute (ANSI), the National Electrical Manufacturer's Association (NEMA), and the regulations and standards of the local power company.
- b. The prime contractor or subcontractor responsible for the performance of the work covered by these SCDOT TRAFFIC SIGNAL SPECIAL PROVISIONS **must be licensed by the SC Licensing Board For Contractors and possess a Journeyman Card issued**

by the South Carolina Municipal Association or as required by the city in which work occurs at the time work is performed.

- c. Further, at least one '**ON-SITE**' field supervisor shall have **LEVEL II** or higher, Traffic Signal Certification by the International Municipal Signal Association (IMSA). Photo copies of the license and certificate (for both above) shall be submitted before work commences. The CONTRACTOR shall retain employee(s) holding the above certificate for the duration of the project; and the employee(s) shall be present **DAILY** and at the **FINAL INSPECTION**.
- d. The CONTRACTOR shall employ persons capable of programming traffic signal controllers of the type used by this project. The CONTRACTOR shall possess both a desktop and a portable (laptop) computer, and be capable of using them to upload and download signal operating parameters.
- e. In addition to the state requirements, all permits and licenses required by a City/County are the responsibility of the CONTRACTOR. The CONTRACTOR shall arrange with the utility company for hookup connections and attachment agreements.

8. INSPECTION

a. Engineer

During construction, the INSPECTION will be the responsibility of the Department. The Department's Construction Office, shall designate those individuals responsible for inspection, and may include a number of qualified persons, including DISTRICT ELECTRICAL SUPERVISOR (DES). For signals located within a local government that SCDOT has a signal maintenance agreement, the inspection personnel may include the local government's Electrical Supervisor to perform inspection for SCDOT.

b. Disputes

The CONTRACTOR is advised that in any dispute between the Contractor and the Manufacturer, concerning the operation/maintainability/reparability of any piece of equipment, **THE DECISION OF THE ENGINEER SHALL BE FINAL.**

c. Faulty Equipment

When equipment supplied by the Department is designated faulty by the Engineer, if it is under warranty, the Contractor shall return it to the Manufacturer for replacement. The Manufacturer shall furnish a replacement unit.

9. MAINTENANCE OF OPERATION

- a. Fixed time operation of signals is not acceptable for this project. In accordance with **688.2 Temporary Adjustment of Traffic Signal Equipment and Timings – Continuity of Signal Operation** CONTRACTOR shall provide temporary actuation devices such as video detection to maintain actuated signal control at all times. The temporary actuation devices shall be installed and operational, and operation shall be transferred to the temporary devices prior to demolition of the existing loop detector systems. It is not permissible to adopt "uncoordinated" operation of adjacent signals; and if the existing interconnection system is broken or disconnected, it shall be repaired immediately. If possible, the District Traffic ENGINEER should be requested to provide temporary controller time settings.
- b. Existing traffic signals shall **REMAIN IN OPERATION** until the new/modified installation has been satisfactorily tested, and it has been placed in operation after approval by the Engineer. The Testing shall be accomplished without hazard to the traveling public and while the signal heads are suitably **BAGGED WITH BURLAP**. All signal heads in place, but not in use, shall be covered with **BURLAP**. **NOTE: PLASTIC BAGS ARE NOT ACCEPTABLE.**
- c. After approval is received from the Engineer, the new signal heads shall be switched into service during that controller phase being displayed by the existing equipment; and the existing equipment shall be turned off simultaneously. Immediately after the new signal equipment has been made operational, the existing signal heads shall be turned off, and removed.
- d. The Contractor is cautioned to PLAN their work to cause minimum interference with any existing signal operation. Adjustments in the existing equipment made necessary by the

EXHIBIT 5 – SPECIAL PROVISIONS

new installation will be made at the expense of the Contractor.

- e. The Contractor shall retain ownership of the materials and equipment after the intersection has been made operational, until Inspection and Acceptance (either partial or final) has been made by the Engineer, when it then becomes SCDOT property. Prior to Acceptance, if the materials or equipment is damaged by whatever cause, the Contractor shall be responsible for repair or replacement.

- f. Operation, Maintenance and Emergency Service-

The contractor shall be responsible for the maintenance and operation of all existing signals in the "LIST OF PROJECT TRAFFIC SIGNALS" from the date of the "NOTICE TO PROCEED" of the contract until the final acceptance of the project. This shall include all daily maintenance of signals and any emergencies which may arise. The CONTRACTOR is also responsible and liable for proper and safe operation of each signal. Herein, this activity will be termed "Maintenance".

- i. Restriction

The CONTRACTOR shall not change the phasing or other operation of a signalized intersection without Departmental approval.

- ii. Procedure

At that point in the project when construction activity is about to occur which could Affect the operation of a particular signal, the CONTRACTOR shall request the Department's concurrence, and the CONTRACTOR shall assume responsibility for operations and maintenance of that traffic signal. This request shall be in writing to the ENGINEER and shall have a written response. In the absence of the request, any activity of the CONTRACTOR which affects the operation of a signal shall be deemed evidence of the CONTRACTOR's assumption of responsibility for the operation and maintenance of the signal.

- iii. New Signals

Signals installed by the CONTRACTOR shall be maintained by the CONTRACTOR until the Department formally accepts the work.

- iv. Requirements

The CONTRACTOR shall perform EMERGENCY REPAIRS AND SERVICES as required, to insure continuity of operation of listed traffic signals and associated equipment. **This shall include replacement of malfunctioning LED modules.**

- v. Technician

The CONTRACTOR shall provide at least one (1) qualified LOCAL signal technician, subject to call at all times, to provide emergency services as required to assure continuous and efficient operation of signal installations and systems. This shall include non-business hours, weekends, and holidays. The Technician shall be fully qualified to trouble-shoot, service, repair and/or replace traffic controllers and components, both electro-mechanical and solid-state. At the PRE- CONSTRUCTION CONFERENCE, the CONTRACTOR shall furnish the RCE with a LIST OF THE SIGNAL TECHNICIANS who will be responsible for performing the emergency service, and the LOCAL PHONE NUMBER(S) of the CONTRACTOR's agent(s) (answering service, etc.), who will receive emergency calls during and after the CONTRACTOR's normal business hours.

- vi. Repair Time

The CONTRACTOR shall be ON-SITE of the malfunctioning signal for emergency service within the maximum time listed in the following schedule-

<u>Weekdays or Saturday</u>	<u>Maximum Time</u>
6 AM to 6 PM	1 hour
6 PM to 6 AM	4 hours
<u>Sundays or Holidays</u>	
Day or Night	4 hours

EXHIBIT 5 – SPECIAL PROVISIONS

- vii. Restoration of Normal Service
Once the CONTRACTOR has started repair work/emergency service, the CONTRACTOR shall restore a malfunctioning signal to normal phase operations uninterrupted.
- viii. Time Changes (EST/DST)
As part of Maintenance, the CONTRACTOR shall reset all time clocks to local legal time.
- ix. Records
The CONTRACTOR shall maintain a LOG of all trouble calls received, the response time, and the corrective action taken. The records and logs shall be available to Department personnel for review during normal working hours. All records and logs shall be turned over to the Department at FINAL ACCEPTANCE.
- x. Failure To Perform
In the event the CONTRACTOR fails to perform in accordance with requirements and schedules of this Specification, the Department reserves the right, without notice to the CONTRACTOR, to engage a Third Party to perform the maintenance and emergency service necessary to assure continuous traffic signal operation. Further, all expenses incurred by the Department in implementing this option, shall be deducted from the payment due the CONTRACTOR, plus a FIFTEEN HUNDRED (\$1500) DOLLAR PENALTY FOR EACH OCCASION. FOR EACH DAY (UNTIL CORRECTED). The penalty shall be forfeited as liquidated damages.

10. CONTRACT SCHEDULE

The CONTRACTOR shall furnish the Engineer with a WEEKLY SCHEDULE for the **TRAFFIC SIGNAL CONSTRUCTION** work, each Friday, for the week to come, listing the location and date of each intended activity. This will permit scheduling signal inspection personnel. Deviation from this schedule may cause the Department to delay Inspection and Payments.

11. PAYMENT FOR MATERIALS ON HAND

The attention of the CONTRACTOR is directed to Section 109.7 of the STANDARD SPECIFICATIONS; which is amended to include the following paragraphs.

When permitted by the Engineer, partial payment will be made for major traffic signal items that are being furnished by the CONTRACTOR. Certain items such as wooden poles, and other very heavy units not readily movable or vandalized, may be stored in un-secured locations either ON- or OFF-SITE. Other items such as signal heads, detector amplifiers, controllers, cabinets, and certain other major items may be stored in a secured/protected location either ON- or OFF-SITE. The equipment shall be labeled stating SCDOT, and the Project Name. Other requirements of Paragraph 109.8 remain applicable. Payment shall be in accordance with the following criteria:

1. For MATERIALS ON HAND, the Contractor may be paid at: FIFTY (50%) PERCENT OF THE CONTRACT UNIT PRICE OF ITEM, NOT TO EXCEED THE PAID INVOICE AMOUNT.
2. ONLY ITEMS MEASURED BY --EACH-- SHALL BE ELIGIBLE.
3. ONLY ITEMS WITH A UNIT PRICE EXCEEDING \$100 SHALL BE ELIGIBLE.
4. THE TOTAL INVOICE PRICE OF THE ITEMS SHALL EXCEED \$5000.

12. SUBMITTING AS-BUILT PLANS

After the completion of the project, the CONTRACTOR shall furnish to the Engineer, three (3) "red-lined" sets of Plans showing the exact locations and sizes of all conduits, poles, pedestals, splice boxes, detectors, and the routing and destination of all wires leaving the control cabinets.

13. FINAL INSPECTION

a. Request

The CONTRACTOR shall request Final Inspection one week prior to the desired day of inspection. Confirmation to the Resident Construction Engineer shall be provided forty-eight (48) hours prior to Final Inspection, that the project is on schedule and ready for inspection.

b. System Test

Upon completion of the Final Inspection and correction of any deficiencies, the work will be subject to a **sixty (60) day operational test** for the System, and for individual intersections. If during this period a problem arises in either the System or an individual traffic signal, it must be resolved, and a **NEW sixty (60) day test** period shall begin.

14. MAINTENANCE OF TRAFFIC

The Contractor shall execute the item of Traffic Control as required by the Standard Specifications, the plans, the Standard Drawings For Road Construction, these special provisions, all supplemental specifications, the MUTCD, and the Engineer.

(46) DIVISION 600: FURNISH AND INSTALL DETECTOR LOOPS:

The Contractor is hereby notified that All Catalog descriptions and documentation are to be submitted within (5) days after the bid openings to the Contracts Administrator.

The loops shall be installed in the surface course on all projects in Engineering Districts 3, 4, 5, 6, & 7.

The loops shall be installed in the binder course for all projects in Engineering District 1.

The loops shall be on installed in the binder course on new construction projects, and in the surface for resurfacing projects in Engineering District 2.

(47) DIVISION 600: EVALUATION OF RETROREFLECTIVITY:

Within 20 days of initial application, the Contractor shall arrange for an independent party to evaluate the retroreflectivity of the pavement markings using a mobile retroreflectometer utilizing 30 meter CEN geometry. All lines shall be measured in both directions. The independent party conducting the measurements shall furnish directly to the Department a report detailing the average of the readings over one mile segments for each type of long line (white edgeline, white lane lines, yellow edgelines) along the length of the project. Average measurements shall also be provided along each ramp. Interstate mile markers may be used for beginning and ending points, with the first and last segments in each direction being less than one mile in length. The initial minimum retroreflectivity values shall be as follows:

Retroreflectivity (mcd/lux/m²)

<u>White</u>	<u>Yellow</u>
450	350

A second evaluation shall take place within 20 days prior to the end of the 180 day observation period. The evaluation method shall be the same as described above. The 180 day minimum retroreflectivity values shall be as follows:

Retroreflectivity (mcd/lux/m²)

<u>White</u>	<u>Yellow</u>
400	300

All markings failing to meet the initial minimum retroreflectivity requirements by more than 50 mcd/lux/m² shall be replaced immediately at the Contractor's expense. All markings failing to meet initial requirements by less than 50 mcd/lux/m² may be reevaluated at the time of the 180 day evaluation unless the defect causing the lower readings is obvious to the Engineer.

(48) DIVISION 600: MANUAL ON UNIFORM TRAFFIC CONTROL DEVICES:

The Contractor is advised that all work involving design or installation of traffic control devices, including but not limited to signs, pavement markings, elements of work zone traffic control, signals, etc., shall be in compliance with the FHWA's Manual on Uniform Traffic Control Devices (MUTCD), latest edition. The latest edition is defined as the edition that the Traffic Engineering Division of SCDOT recognizes as having been officially adopted (Engineering Directive, Memorandum 19) at the time the project is let, unless stated otherwise in the Special Provisions.

(49) DIVISION 600: RULE ON WORK ZONE SAFETY AND MOBILITY:

The CONTRACTOR is responsible for complying with the Rule on Work Zone Safety and Mobility. This Project is classified as "**Significant**". The Contractor shall submit a Traffic Management Plan in compliance with the Rule on Work Zone Safety and Mobility. See "Rule on Work Zone Safety and Mobility" in the Project Information section.

(50) SECTION 601: PENALTY FOR VIOLATING LANE CLOSURE RESTRICTIONS:

The Contractor is advised that the Lane Closure Restrictions outlined in the Traffic Control Special Provisions will be strictly enforced. Should lane closures remain in place or not be completely removed by the time specified in the Traffic Control Special Provisions, a penalty will be assessed at the rate of **\$2,500.00 (Two Thousand Five hundred Dollars)** for each 1/4 hour interval (or any portion thereof). Should lane closures remain in place or not be completely removed for a period of longer than one hour beyond the time specified by the Traffic Control Special Provisions the penalty will increase to **\$5,000.00 (Five Thousand Dollars)** for each 1/4 hour interval (or any portion thereof).

(51) SECTION 601: HOLIDAY RESTRICTIONS:

The Holiday Restrictions Supplemental Specification, dated September 1, 2015, shall apply to this project.

(52) SECTION 605: PERMANENT CONSTRUCTION SIGNS:

Utility locations must be performed prior to the placement of Permanent Construction Signs. State Law requires that the location of each sign be marked with a white line in the roadway or a stake in the shoulder. The locator company will mark 25 feet on either side of the location. The responsibility for marking the sign locations prior to the contractor calling PUPS for utility locate lies with the party responsible for lines and grades on the project. If Construction Lines and Grades is a pay item, then the Prime Contractor is responsible for marking the sign location. If this is not included, it is the Department's responsibility to mark the locations.

Prior to marking the sign location, care must be taken when marking the signs to ensure that there are no obstructions or other mitigating factors that will cause the sign to be moved outside of the 50 foot utility window. Any costs associated with staking out the sign locations are considered incidental to the cost of Permanent Construction Signs.

Requests for utility locates must be specific and isolated to the sign locations if no ground disturbing activities are occurring outside of the sign placement.

(53) SECTION 610: WORK ZONE TRAFFIC CONTROL PROCEDURES:

The first sentence of Section 610.3 of the 2007 Standard Specifications is hereby revised to:

"Ensure that background color of personal protective apparel is either fluorescent Yellow-Green or fluorescent Orange-Red, and meets ANSI Standard 107-2004 National Standard for

EXHIBIT 5 – SPECIAL PROVISIONS

High Visibility Apparel Class 2 (or Class 3 as necessary) Performance Criteria, or latest edition.”

Note #12 of Standard Drawing 610-005-00 is hereby revised to:

“During nighttime flagging operations, flaggers shall wear a Safety Vest and Safety Pants meeting ANSI Standard 107-2004 National Standard for High Visibility Apparel Class 3 Performance Criteria, or Latest Edition, and a Hardhat. The color of the apparel background material shall be either fluorescent Yellow-Green or fluorescent Orange-Red.”

**(54) SECTION 653: RETROREFLECTIVE SIGN POST PANELS:
Section 653 is hereby modified as follows:**

653.2 Materials - Add the following paragraph:

Use retroreflective sign post panels constructed of a nonmetallic composite or 3mm aluminum composite material approved by the SCDOT covered with a 3-inch wide type III sheeting. Use sheeting that meets the requirements of Section 651.2.3. Use approved panels included on the Approved Products List For Traffic Control Devices in Work Zones.

653.4.2 Erection - Add the following paragraph:

Mount the panel for the full length of the post from the sign to within 6 inches above the edge of the roadway. Mount panel only on post specified in the plans or special provisions. Secure the panel to the post with a minimum of 3 5/16-inch bolts and a lock washer and flat washer between post and nut, or tamper-resistant and rust-resistant screws. Use bolts, washers and nuts meeting the requirements of section 651.2.2. Provide the sheeting in the color that matches the background color of the sign except that the color for the “Yield” and “Do No Enter” signs shall be red. Install panels to both posts, if there are two posts supporting the sign.

653.5 Measurement is replaced with the following:

653.5 Measurement

The quantity for the pay item U-Section Post for Sign Support – (2 or 3)P, U-Section Post for Sign Bracing –2P or retroreflective sign post panel is the length of U-section post used for sign support or bracing or panel and is measured to the nearest 1/100 of a linear foot (LF) of the required post or panel, complete and accepted.

653.6 Payment is replaced with the following:

653.6 Payment

Payment for the accepted quantity for U-Section Post for Sign Support – (2or 3)P, U-Section Post for Sign Bracing –2P or Retroreflective Sign Post Panel, measured in accordance with **Subsection 653.5**, is determined using the contract unit bid price for the applicable pay item, and the payment includes all direct and indirect cost and expenses necessary to complete the work.

Payment is full compensation for fabricating and erecting U-section posts or braces or panels as specified or directed and includes providing mounting hardware; removing and disposing of existing signs supports, braces, and mounting hardware removed or replaced; replacing or relocating supports or braces shown on the Plans or directed by the RCE; and all other materials, labor, equipment, tools, supplies, transportation, and incidentals necessary to fulfill the requirements of the pay item in accordance with the Plans, the Specifications, and other terms of the Contract.

EXHIBIT 5 – SPECIAL PROVISIONS

Pay items under this section include the following:

Item No.	Pay Item	Unit
6531205	U-Section Post for Sign Supports – 2P	LF
6531210	U-Section Post for Sign Supports – 3P	LF
6531215	U-Section Post for Sign Bracing – 2P	LF
6531500	Reflective Sign Post Panels	LF

(55) DIVISION 700: BEARING REPLACEMENT:

At locations identified in Exhibit 4, replace the existing expansion bearings with elastomeric bearings. Jack and raise the spans to permit the removal of the existing bearings and installation of the new elastomeric bearings prior to the connecting of the new and existing superstructures. Remove and dispose of the existing bearing assemblies and replace with structural steel pedestals and/or plates, bearing plates, and laminated elastomeric pads. At locations where rocker bearings are being replaced, construct reinforced concrete build-ups below the new bearing assemblies.

Prior to beginning this work, submit 6 copies of working drawings and design calculations. On the plans, show the placement of all jacks, the load carried by each jack, the load capacity of each jack, the bearing stress on concrete surfaces, the design and installation of any temporary support system, and the sequence of work.

Locate jacking points as near the bearings as possible. Jacking points shall not be under the slab. Repair or replace, at the Contractor's expense, any damage caused by jacking.

Design and detail the bearing replacement operation such that traffic is maintained on the bridges during the bearing replacements. Also, design and detail the bearing replacement operation such that upon completion of the replacements, the finished deck elevations of the bridges match the existing deck elevations.

(56) DIVISION 700: CONNECTIONS TO EXISTING STRUCTURAL STEEL:

The Contractor is advised that this project requires field bolting of new connection plates to the existing beams and girders. The existing beams and girders contain lead based paint and therefore work shall comply with all applicable federal, state, and municipal requirements for lead as waste; for lead in the air, water, and soil; and for worker health and safety.

Prior to connection of new plates, the Contractor shall clean the contact surfaces of the existing girder web and flanges. The cleaning methods shall remove all existing paint, rust, and mill scale and shall produce a clean surface acceptable for a clean connection to the existing steel surface. These areas shall be cleaned in accordance with The Steel Structures Painting Council Surface Preparation Specification SSPC - No. 11. Cleaning methods shall be such as to not cause lead pollution and shall comply with all requirements shown above. The Contractor shall submit the proposed cleaning method to the RCE for review and approval prior to beginning this work.

After cleaned areas are accepted by the RCE, the Contractor shall repaint cleaned areas with one coat of a SCDOT approved Aluminum Epoxy Mastic Paint. A smooth uniform coating with a minimum dry film thickness of 5 mils shall be obtained without film cracking, sagging or loss of adhesion. Cleaning of these areas before painting shall be in accordance with The Steel Structures Painting Council Surface Preparation SSPC - SP6. The quality of the cleaning before painting shall be such that the coating of Aluminum Epoxy Mastic Paint will adhere tightly to the steel in all cases. The Aluminum Epoxy Mastic Paint shall be applied by the Paint Manufacturer's recommendations. The Contractor may also be required to clean and repaint the areas on the opposite side of the girder web or girder flange if damaged by the connection operation.

(57) DIVISION 700: JOINT REPLACEMENT:

Requirements for Resealing Deflection Joints and Expansion Joints:

At locations identified in Exhibit 4, remove and dispose of the existing joint material. Sandblast the concrete surface in the joint. Immediately before placing new joint filler, remove all dust, sand, and blasting debris with oil-free compressed air. Place cold applied elastic filler in the joint opening. Before placing the filler, all concrete surfaces shall be thoroughly cleaned and dry.

Requirements for Replacing Expansion Joints having Existing Elastomeric Concrete Headers:

At locations identified in Exhibit 4, remove and dispose of the existing elastomeric concrete and joint seals. Saw-cut along the edge of the existing elastomeric concrete. Remove all existing elastomeric concrete. Limit the maximum size of jackhammers to 15 pounds. Do not damage the vertical sides of the saw-cut during concrete removal. Remove all grease, dirt, oil, or foreign material from the patch areas by blast cleaning. Immediately before placing new concrete, remove all dust, sand, and blasting debris with oil-free compressed air. Place the new elastomeric concrete and install the new compression seals. Before placing the elastomeric concrete, all concrete surfaces shall be thoroughly cleaned and dry.

Requirements for Replacing Expansion Joints without Existing Elastomeric Concrete Headers:

At locations identified in Exhibit 4, remove and dispose of the existing joint seals. Remove all grease, dirt, oil, or foreign material from the joint areas by blast cleaning and remove all dust, sand, and blasting debris with oil-free compressed air. Install the new compression seals.

Select the size of the replacement joints based on the existing joint openings and in accordance with the requirements of Exhibit 4.

(58) DIVISION 700: SUBSTRUCTURE PATCHING:**GENERAL**

This Special Provision supplements the SCDOT Standard Specifications when repairs of spalls, pop-outs, scaling, or other distressed areas are required in existing concrete.

MATERIALS

Prepare an epoxy resin repair mortar/concrete in accordance with the manufacturer's instructions regarding aggregates and gradation of aggregate. Provide epoxy resin adhesive in accordance with ASTM C 881. For patches applied to vertical surfaces, ensure the adhesive is rated for overhead use. Submit the proposed epoxy resin and epoxy mortar/concrete mix design to the OMR and furnish a copy to the RCE. Mix design shall be compatible with the class of concrete specified on the existing bridge plans. Do not use the mix until it has been accepted by the OMR.

CONSTRUCTION

Areas to be repaired shall be determined by the RCE using a rod, hammer, or other device to determine defective or delaminated areas. The extent of the repair area will be marked by the RCE.

Outline the defective areas and verify depth of concrete cover over reinforcing steel. Saw-cut the outlined areas to a minimum depth of 1.5 inches, if possible without cutting any reinforcing steel.

Remove all defective and/or delaminated concrete in the outlined areas by use of jackhammers. Limit the maximum size of jackhammers to 15 pounds. Do not damage the vertical sides of the saw-cut during concrete removal.

Remove all grease, dirt, oil, or foreign material from the patch areas by blast cleaning. Immediately before placing patching material, remove all dust, sand, and blasting debris with oil-free compressed air.

EXHIBIT 5 – SPECIAL PROVISIONS

Ensure that the surface to receive the patch is clean and dry. Apply an SCDOT approved rust inhibitor to all exposed reinforcing steel in accordance with manufacturer's instructions.

Precondition the epoxy resin and the catalyst before blending to produce a blended liquid that is between 75° F and 90° F. The epoxy components shall be mixed in strict compliance with the manufacturer's mixing instructions before aggregates are added to the mixture. The mixture shall be blended in a suitable mixer (as specified) to produce a homogeneous mass. Only that quantity of material that is usable in one hour shall be mixed at one time. Material that has begun to generate appreciable heat shall be discarded.

Prime the entire clean surface of the repair area with neat blended epoxy immediately before the mixture is placed. Priming shall include overlapping the surface of the area adjacent to the repair. Place and tamp the mixture with sufficient effort to eliminate voids and to thoroughly compact the product. Screed and texture the surface to produce the required finish and grade. For deck applications, allow the repair area to remain undisturbed for at least 3 hours before it is subjected to traffic. Fill saw cut "run-outs" with the mortar of the repair material.

PAYMENT

The quantity of epoxy mortar patch to be paid for will be the actual number of square feet of spalls, popouts, scaling, or other distressed areas in existing concrete which have been patched and accepted. This work includes cleaning, removing, and disposing of debris from the patching work, furnishing patching material, and all other materials, labor, equipment, tools, supplies, transportation, and incidentals necessary to fulfill the requirements of this item of work.

Pay Item Number	Pay Item	Unit
8990242	Epoxy Mortar Patch	SF

QUANTITY

The Contractor's bid shall include 135 square feet of epoxy mortar patching within the overall project limits as directed by SCDOT. If more than 135 square feet of patching are required by SCDOT, the Contractor will be paid a unit price of **\$225.00 per square foot** for the patching. If less than 135 square feet of epoxy mortar patching are required, the Contractor shall reimburse SCDOT, at a unit price of **\$225.00 per square foot**, for the quantity of epoxy mortar patch that was not needed.

(59) SECTION 701: NON-CONFORMING CONCRETE:

For purposes of applying the reduced payment and below strength provisions of Subsection 701.2.12.4 of the Standard Specifications, a unit price of **750 dollars per cubic yard** will be used.

(60) SECTION 703: REINFORCING STEEL:

The Reinforcing Steel Supplemental Specification, dated August 3, 2015, shall apply to this project.

(61) SECTION 711: PILE AND DRIVING EQUIPMENT DATA FORM:

Pile and Driving Equipment Data Form is included in Attachment B.

(62) SECTION 712: DRILLED SHAFT FORMS:

Drilled Shaft Forms are included in Attachment B.

(63) SECTION 712: BI-DIRECTIONAL STATIC LOAD TESTING OF DRILLED SHAFTS:

July 20, 2015 ~~April 14, 2015~~

1.0 GENERAL

This work shall consist of furnishing all materials, equipment, labor, and incidentals

EXHIBIT 5 – SPECIAL PROVISIONS

necessary for conducting bi-directional static load testing of 1 drilled shaft. In addition, ~~the structural integrity of the test drilled shaft,~~ the load-deflection and soil-load transfer relationships shall also be determined. Production drilled shaft lengths may be adjusted after results of the test drilled shaft have been analyzed. No materials shall be ordered until drilled shaft lengths are approved by the Department. The test shaft depth, diameter, and location shall be as specified in the plans. The testing specified in the project documents shall be conducted in general accordance with ASTM D1143 - *Standard Test Method for Piles Under Static Axial Load*. The bi-directional static load test shall be performed as shown on the plans.

The bi-directional static load test cell equipment shall have sufficient capacity to fully mobilize the test drilled shafts' nominal capacity. The applied load shall at least be equivalent to the test drilled shaft load specified in the plans.

The location of the test drilled shaft (non-production) shall be as indicated in the plans. The test drilled shaft shall maintain a minimum distance of 25 feet from any foundation element of any future bent. The Contractor shall submit the proposed location to the Department for approval.

Load testing of the test drilled shaft shall not begin until the concrete has attained a compressive strength (f'_c) as indicated in the plans and had a curing time of no less than 7 days. High early strength concrete may be used to obtain the required strength at an earlier time to prevent testing delays, upon the approval of the Department.

The bi-directional static load testing shall be performed using the number of load cells and at the locations indicated in the plans. The Contractor will be required to furnish and include all costs in the bid item for all materials, personnel, and equipment as described in the plans, this Supplemental Technical Specification, the Special Provisions and as required by the contract to adequately perform Bi-Directional Static Load Testing of Drilled Shafts. The Contractor shall engage the services of an approved bi-directional static load test supplier for instrumenting, performing, and reporting of the bi-directional static load test. The Contractor may contact the Engineer for names of bi-directional static load test suppliers. The drilled shaft used for the load test program will be instrumented by the bi-directional static load test device supplier. The Contractor shall subcontract with the bi-direction static load test manufacturer to supply the bi-directional static load test cells and other necessary equipment and instrumentation, perform the test, and analyze the results of the bi-directional static load test ~~on 1 test drilled shaft.~~

The Contractor shall submit to the Department for approval 3 sets of shop drawings, erection plans, test calculations and details associated with the axial bi-directional static load testing within 21 days following the Notice to Proceed. The submittal shall include details with respect to the reinforcement cage fabrication, instrumentation plans, reference beams and movement measuring systems. All details, drawings, calculations, and procedures shall be submitted to the Department for review a minimum of 21 days prior to beginning the axial bi-directional static load test. Approval of this submittal by the Department shall not relieve the Contractor from making subsequent changes that may become necessary to carry out the test.

The Contractor, in cooperation with the selected bi-directional static load test supplier, shall supply and supervise the mobilization, assembly, and operation of the bi-directional static load test equipment. The ~~of~~ bi-directional static load test supplier shall provide and install the required instrumentation for the test drilled shaft, acquire the test data during testing, and reduce the data into a report. This report shall be presented to the Contractor and the Department for evaluation. Interpretation of the test data with regard to foundation recommendations will be performed by the Department.

2.0 MATERIALS & EQUIPMENT

The Contractor shall supply all materials required to install the bi-directional static load test

EXHIBIT 5 – SPECIAL PROVISIONS

device, conduct the load test, and remove the load test apparatus as required. The Contractor shall furnish the number of bi-directional static load test assemblies as required in the plans for the test drilled shaft. The bi-directional static load test assemblies to be provided shall have a capacity that fully mobilizes the test drilled shafts' nominal capacity and shall be equipped with all necessary hydraulic lines, fittings, pressure source, pressure gage and telltale devices.

Additional materials required include, but are not limited to, the following:

1. Fresh, clean, potable water from an approved source to be used as hydraulic fluid to pressurize the bi-directional static load test devices.
2. Materials sufficient to construct and shade a stable reference beam system for monitoring movements of the drilled shaft during testing. The system shall be supported at a minimum distance of 3 shaft diameters from the center of the test drilled shaft to minimize disturbance of the reference system. A tripod shall be provided to support an automated digital survey level used to monitor movement of the reference system during testing. Alternatively, 2 survey levels located in excess of 3 shaft diameters may be used to monitor the top of drilled shaft displacement in lieu of the beam. In this case, 2 tripods and weather protection (Quikshade or equivalent) shall be provided.
3. Materials sufficient to construct a protected work area (including provisions such as a tent or shed for protection from inclement weather for the load test equipment and personnel) of size and type required by the Engineer and the bi-directional static load test supplier. In the case of cold weather, the protected work area shall be maintained at a temperature above 40° F in order to insure proper operation of the load testing equipment.
4. Stable electric power source, as required for lights, welding, instruments, etc.
5. Materials such as angle or channel iron, steel bearing plates and/or other devices needed to attach the bi-directional static load test assembly to rebar cage or carrying frame, as required.

Materials supplied which do not become a part of the finished structure become the property of the Contractor at the conclusion of the load test and shall be removed from the job site.

The Contractor shall supply equipment required to install the bi-directional static load test devices, conduct the load tests, and remove the load test apparatus as required. Equipment required includes but is not limited to:

1. Welding equipment and certified welding personnel, as required, to assemble the test equipment under the supervision of the bi-directional static load test supplier and to attach hydraulic fittings and telltales to the bi-directional static load test devices, and prepare the work area.
2. Equipment and labor to construct the reinforcing steel cage and/or placement frame required for the test drilled shaft, including steel bearing plates as required.
3. Equipment and operators for handling the bi-directional static load test device and instrumentation and placement frame or reinforcing steel cage during the installation of the bi-directional static load test device and during the conduct of the test, including but not limited to a crane or other lifting device for bi-directional static load test device and instrumentation, manual labor, and hand tools as required by bi-directional static load test supplier.

EXHIBIT 5 – SPECIAL PROVISIONS

4. Equipment and labor sufficient to erect the protected work area and monitoring reference beam system, to be constructed to the requirements of the Engineer and bi-directional static load test supplier.
5. Air compressor (minimum 150 cfm) for pump operation during load testing.
6. Strain Gauges – the Contractor shall supply the number of strain gauges as required at each level. The number of strain gauges will be determined as shown in the plans. All cost for supplying strain gauges will be included in the price bid for Bi-Directional Static Load Testing of Drilled Shafts, and no additional payment will be made for this equipment.

3.0 PREPARATION FOR TESTING

The Contractor shall perform site and foundation preparation. Foundation preparation includes the cutting and cleaning of the surface of the test drilled shaft down to test elevation. The top of the test drilled shaft shall be smooth and level. The area around the test drilled shaft, on land, shall be leveled and compacted within a 15-foot radius. The top of the drilled shaft should be approximately 1-1/2 diameters above grade for axial testing. For over water or elevated work areas, the area provided shall be level and at the test elevation. The support falsework platform shall be assembled and installed by the Contractor at the test location.

Prior to performing the load test, the Testing Engineer shall be provided with soil boring logs, test shaft installation records, concrete properties (strength, etc.) and details regarding the anticipated dynamic loading equipment. The Testing Engineer is required to perform wave equation analyses (using GRLWEAP or equivalent) to determine the suitability of the proposed dynamic load testing equipment and an acceptable range of drop weight heights so as not to cause damage in the test shaft during the test. ~~If High Strain Dynamic Load Test becomes necessary after the construction letting, then the Contractor shall provide notice of this requirement to the Department at least 45 days in advance of the test.~~

For the test drilled shaft, proposed instrumentation location shall be provided to the Department a minimum of 7 days prior to the fabrication of the drilled shaft reinforcement cage. The Department will provide comments for the final instrumentation locations within 3 days after receiving this information.

Strain and pressure gage instrumentation, displacement transducers, CSL access tubes, bi-directional static load testing devices and any other materials and equipment required by bi-directional load test supplier shall be installed on the reinforcing cage.

Immediately prior to placement of the reinforcement cage, the dimensions and verticality of the drilled shaft excavation shall be determined by the bi-directional load test supplier using a method approved by the Engineer.

CSL testing will be performed by the Department personnel or a Department designated representative in accordance with Section 727 of the Standard Specifications.

The axial bi-directional static load testing shall not begin until at least 4 days after CSL testing and until the concrete has attained the compressive strength (f_c) as indicated in the plans.

The Contractor shall cooperate with the Department's personnel whom shall be granted access to all facilities necessary for observation of the test and the viewing of the test results.

The Contractor shall perform the test drilled shaft excavation in accordance with Section 712 of the Standard Specifications.

EXHIBIT 5 – SPECIAL PROVISIONS

The bi-directional static load test cells, hydraulic supply lines and other instruments will be assembled and made ready for installation under the direction of bi-directional static load test supplier and the Department, in a suitable area, adjacent to the test shaft, to be provided by the Contractor. The bi-directional static load test assemblies shall be welded to the rebar cage or carrying frame. The plane of the bottom plate(s) of the bi-directional load test cell(s) shall be set at right angles to the long axis of the cage. The Contractor shall use the utmost care in handling the test assembly so as not to damage the instrumentation during installation. The Contractor shall limit the deflection of the cage to 2 feet between pick points while lifting the cage from the horizontal position to vertical. The maximum spacing between pick points shall be 25 feet. The Contractor shall provide support bracing, strong backs, etc. to maintain the deflection within the specified tolerance. The bi-directional load test assemblies must remain perpendicular to the long axis of the reinforcing cage throughout the lifting and installation process.

When the test drilled shaft excavation has been completed, inspected, callipered using the approved equipment and accepted by the Department, the bi-directional static load test assembly and the reinforcing steel may be installed. A seating layer of concrete shall be placed in the base of the shaft to provide a level base and reaction for the lower bi-directional static load test assembly. The seating layer shall be placed using a pump line or tremie pipe extending through the bi-directional static load test assemblies to the base of the shaft. After seating the bi-directional static load test device assembly, the remainder of the drilled shaft shall be concreted in a manner similar to that specified for production shafts. At least 4 concrete test cylinders, in addition to those specified elsewhere, shall be made from the concrete used in the test drilled shaft, to be tested at the direction of bi-directional static load test supplier. At least 1 of these test cylinders shall be tested prior to the load test and at least 2 cylinders shall be tested on the day of the load test.

4.0 PROCEDURE FOR LOAD TESTING

The load testing shall be performed by a qualified geotechnical engineer approved in advance by the Department. The geotechnical engineer must have a demonstrated knowledge of load testing procedures, and have performed at least 10 bi-directional static load tests within the past 2 years. The load testing shall be performed in general compliance with ASTM D1143 using the Quick Load Test Method for Individual Piles. Initially the loads shall be applied in increments equaling 5 to 10% of the anticipated nominal capacity of the test shaft. The magnitude of the load increments may be increased or decreased depending on the project requirements but should not be changed during the test.

~~Loads shall be applied in 3 stages by: 1) pressurizing the lower bi-directional static load test device while the upper assembly remains closed, 2) pressurizing the upper bi-directional static load test device while the lower bi-directional static load test device is allowed to freely drain and 3) pressurizing the upper bi-directional static load test device while the hydraulics are closed on the lower bi-directional static load test device.~~ Loads shall be applied at the prescribed intervals until the ultimate capacity of the shaft is reached in either end bearing or side shear, until the maximum capacity or maximum stroke of an bi-directional static load test device is reached, or unless otherwise directed by the Department. At each load increment, or decrement movement indicators shall be read at 1, 2, 4 and 8-minute intervals while the load is held constant. During unloading cycles the load decrement shall be such that at least 4 data points are acquired for the load versus movement curve. Additional cycles of loading and unloading using similar procedures may be required by the Department following the completion of the initial test cycle.

During the load test, no casings may be vibrated into place in the foundation area, within a 100 ft radius of the load test. Drilling may not continue within a 100-foot radius of the test drilled shaft. If test apparatus shows any interference due to construction activities outside of this perimeter, such activities shall cease immediately.

After the completion of the load test, and at the direction of the Department, the Contractor shall remove any equipment, material, waste, etc. which are not to be a part of the finished

structure.

5.0 INSTRUMENTATION

Direct movement indicator measurements should be made of the following: bi-directional static load test device expansion either directly or with telltales (minimum of 3 indicators required), upward top-of-shaft displacement (minimum of 2 indicators required) and shaft compression above bi-directional static load test device (minimum of 2 indicators required). Displacement sensors used to measure bi-directional static load test device expansion and top-of-shaft displacement should have a minimum travel of 4 inches and be capable of being read to the nearest 0.001 inch division. When bi-directional static load test device expansion is measured directly, Linear Vibrating Wire Displacement Transducers (LVWDTs) capable of measuring the full stroke of the bi-directional static load test device will be used (typically 6 inches). Displacement sensors used to measure shaft compression should have a minimum travel of 1 inch and be capable of being read to the nearest 0.001 inch division.

6.0 REPORTING OF RESULTS

Unless otherwise specified by the Department, the Contractor will supply 4 paper copies of a report of each load test, as prepared by bi-directional static load test device and a PDF electronic copy. An initial data report containing the load-movement curves and data tables will be provided to the Department within 3 working days of the completion of load testing, to allow evaluation of the test results. A final report on the load testing shall be submitted to the Department within 7 working days after completion of the load testing.

7.0 METHOD OF MEASUREMENT

The Bi-Directional Static Load Tests of Drilled Shaft shall be considered to include any material, labor, equipment, load cells, etc. required above the requirements of production drilled shaft installation necessary to install, conduct, and remove the drilled shaft load test at the direction of the Department and bi-directional static load test supplier representative. All costs of the axial load test including subcontracting to bi-directional static load test supplier will also be included in the price bid for this work.

The quantity of the pay item "Bi-Directional Static Load Test of Drilled Shafts" is measured by each (EA) completed and accepted by the Department. A completed Bi-Directional Static Load Test shall be 1 test conducted on a test drilled shaft using Bi-Directional Static Load Testing System, and meeting +/- 15 percent of, or exceeding the target test peak load as specified in the plans

All costs associated with the normal production of the drilled shaft are measured and paid for elsewhere in the contract documents.

8.0 DISPOSITION OF TEST SHAFT

After completion of all testing and the submittal of the required reports, the test drilled shaft shall be cut-off at a depth of 2 feet below the ground surface. The cut-off portion of the shaft shall be properly disposed of by the contractor and the resulting hole shall be backfilled with soil in accordance with Section 205 of the Standard Specifications. The test area shall be graded smooth. In addition, the location of this test drilled shaft shall be indicated on the As-Built plans for this project.

9.0 BASIS OF PAYMENT

The complete and accepted "Bi-Directional Static Load Test" shall be paid for at the contract lump sum price for each. This shall constitute full compensation for all costs incurred during the procurement, installation, conducting of the test, subsequent removal of test apparatus and appurtenances and disposing of the test shaft as described in Section 8.0 above.

10.0 PAYMENT

Payment shall be made under SCDOT Pay Item No. 7120400, "Bi-Directional Static Load Testing of Drilled Shafts."

(64) SECTION 712: RAPID LOAD TESTING OF DRILLED SHAFTS:

July 20, 2015 ~~April 14, 2015~~

1.0 GENERAL

This work shall consist of performing a rapid axial compression load test on a test drilled shaft for the purpose of determining and/or verifying the nominal bearing resistance that may be used in the design of production drilled shafts. In addition, ~~the structural integrity of the test drilled shaft,~~ the load-deflection and soil-load transfer relationships shall also be determined. Production drilled shaft lengths may be adjusted after results of the test drilled shaft have been analyzed. No materials shall be ordered until drilled shaft lengths are approved by the Department. The test drilled shaft depth, diameter, and location shall be as specified in the plans. The testing specified in the project documents shall be conducted in general accordance with ASTM D7383 – *Standard Test Method for Axial Compressive Force Pulse (Rapid) Testing of Deep Foundations* and this ~~Supplemental Technical Specification~~ **Special Provision.**

The Rapid Load Testing equipment shall have sufficient capacity to fully mobilize the test shafts' ultimate nominal bearing resistance ~~shown in the plans. The applied load shall at least be equivalent to the test drilled shaft load specified in the plans, if greater than the nominal bearing resistance.~~

The location of the test drilled shaft (non-production) shall be as indicated in the plans. The test drilled shaft shall maintain a minimum distance of 25 feet from any foundation element of any future bent. The Contractor shall submit the proposed location to the Department for approval.

Load testing of the test drilled shaft shall not begin until the concrete has attained a compressive strength (f'_c) as indicated in the plans and had a curing time of no less than 7 days. High early strength concrete may be used to obtain the required strength at an earlier time to prevent testing delays, upon the approval of the Department.

The Contractor will be required to furnish and include all costs in the bid item for all materials, personnel, and equipment as described in the plans, this and other applicable Special Provisions, and as required by the contract to adequately perform the Rapid Load Test. The Contractor shall engage the services of an approved Rapid Load Test supplier for instrumenting, performing, and reporting of the load test. The Contractor may contact the Engineer for names of Rapid Load Test suppliers.

The Contractor shall supply the name and qualifications of the selected Rapid Load Test supplier a minimum of 30 days prior to conducting the Rapid Load Test. The Contractor shall submit to the Department for approval 3 sets of shop drawings, erection plans, and test calculations and details. The Contractor should include details with respect to the movement measuring system, the piston support system, and the method for measuring the applied load. The Contractor shall also submit details and shop drawings of the proposed set up for review by the Department 2 weeks prior to beginning construction of the testing arrangements (including the test drilled shaft). All details, drawing calculations, and procedures shall be submitted to the Department for review a minimum of 2 weeks prior to beginning the Rapid Load Test. Approval of these submittals by the Department shall not relieve the Contractor from making subsequent changes that may become necessary to carry out the test.

The Contractor, in cooperation with the Rapid Load Test supplier will supply and supervise the mobilization, assembly, and operation of the Rapid Load Test equipment. Rapid Load Test supplier shall provide and install the required instrumentation for the test drilled shaft, acquire the test data during testing, and reduce the data into a report. This report shall be presented to the Contractor and the Department for evaluation. Interpretation of the test data with regard to foundation recommendations will be performed by the Department. Rapid testing is non-destructive and entails no greater danger of shaft damage than static load testing.

2.0 MATERIALS & EQUIPMENT

The Contractor will supply all materials, personnel and equipment as described below and as required by the Contractor and the Rapid Load Test supplier to adequately perform the Rapid Load Test. Such materials and equipment are:

1. Rapid Load Testing apparatus, including pressure chamber and cylinder, reaction masses, exhaust silencer, gravel structure, gravel structure base frame, and all items specifically incidental to the Rapid Load Test system.
2. Foundation top plate (and follower assembly, if needed), adequate to distribute the applied rapid test load to the test shaft.
3. Rapid Load Test device, acceleration transducers, and data acquisition system pertaining directly to the Rapid Load Test device. All required electronic equipment for the recording, processing, and storage of the Rapid Load Test will be operated by the Rapid Load Test supplier.
4. Resistance based strain gages and sufficient cabling (as required).
5. One Geotechnical Engineer, licensed Professional Engineer in South Carolina, and one technician experienced in the implementation of the Rapid Load Test methods who will direct the test setup, perform the testing, direct the disassembly of the test apparatus, provide load test submittals, provide assistance as needed with pertinent Rapid Load Test issues, and provide a written report. Both the engineer and the technician shall, individually, have at least 2 years' experience in Rapid Load Testing.

Additional materials required for the Rapid Load Test shall be supplied by the Contractor as specified by the Rapid Load Test supplier and include, but are not limited to, the following:

1. Support piles for falsework platform. A falsework platform is not required for land based testing. However, materials such as crane mats and plywood may be necessary to provide a level and firm surface to assemble the Rapid Load Test device on land based testing.
2. If the nominal resistance provided on the plans is in excess of 2,000 tons then approximately 180 tons of $\frac{3}{4}$ -inch of gravel with less than 5 percent fines shall be provided as required by the Rapid Load Test supplier. If more than 1 Rapid Load Test is to be conducted over land, it is anticipated that the Contractor shall provide the necessary equipment to move the gravel between Rapid Load Test sites. The gravel material must be approved by the Department. (Note that #67 Stone has been used successfully in the past.)

The Contractor shall supply any additional equipment and personnel to assemble, perform, disassemble, and move to next test site (if applicable). This equipment includes, but is not limited to, the following:

1. Unloading and loading of the Rapid Load Test device trucks during mobilization and

demobilization.

2. Any necessary on-site mobilization of test equipment.
3. A level and firm surface surrounding the test drilled shaft to support the Rapid Load Test device.
4. A level and smooth drilled shaft top. The top of the test drilled shaft shall incorporate permanent casing length as indicated in the plans and have a minimum ½-inch wall thickness. There shall be at least 6 inches between the top of the test drilled shaft and the top of casing left in place.
5. A crane, rigging and operator capable of lifting, unloading, assembling, disassembling, and packing all Rapid Load Test device equipment. The crane and rigging should be of sufficient size and strength to handle the required Rapid Load Test device equipment.
6. Power source adequate for electronic equipment.
7. For over water tests only, welding equipment and welder for falsework platform.

3.0 PREPARATION FOR TESTING

The Contractor shall perform site and foundation preparation. Foundation preparation includes the cutting and cleaning of the surface of the test drilled shaft down to design or test elevation. The top of the test drilled shaft shall be smooth and level. The area around the test drilled shaft, on land, shall be leveled and compacted within a 15-foot radius. The top of the drilled shaft should be approximately 2 feet above grade for axial testing. For over water or elevated work areas, the area provided shall be level and at the test elevation. The support falsework platform shall be assembled and installed by the Contractor at the test location.

Prior to performing the load test, the Testing Engineer shall be provided with soil boring logs, test shaft installation records, concrete properties (strength, etc.) and details regarding the anticipated dynamic loading equipment. The Testing Engineer is required to perform wave equation analyses (using GRLWEAP or equivalent) to determine the suitability of the proposed dynamic load testing equipment. ~~If Rapid Load Testing becomes necessary after the construction letting, then the Contractor shall provide notice of this requirement to the Department at least 45 days in advance of the test.~~

For the test drilled shaft, proposed instrumentation location shall be provided to the Department a minimum of 7 days prior to the fabrication of the drilled shaft reinforcement cage. The Department will provide comments for the final instrumentation locations within 3 days after receiving this information.

Strain and pressure gage instrumentation, displacement transducers, CSL access tubes, Rapid Load Testing devices and any other materials and equipment required by Rapid Load Test supplier shall be installed on the reinforcing cage.

Immediately prior to placement of the reinforcement cage, the dimensions and verticality of the drilled shaft excavation shall be determined by the Contractor using a **sonic calibration** method approved by the Engineer.

CSL testing will be performed by the Department personnel or a Department designated representative in accordance with Section 727 of the Standard Specifications.

The Contractor shall perform the test drilled shaft excavation in accordance with Section 712 of the Standard Specifications.

The Contractor shall use the utmost care in handling the test assembly so as not to damage the instrumentation during installation. The Contractor shall limit the deflection of the cage to 2 feet between pick points while lifting the cage from the horizontal position to vertical. The maximum spacing between pick points shall be 25 feet. The Contractor shall provide support bracing, strong backs, etc. to maintain the deflection within the specified tolerance.

4.0 PROCEDURE FOR LOAD TESTING

The Contractor shall assist the Rapid Load Test supplier as necessary during all aspects of the Rapid Load Test. The following steps shall be taken in the performance of the Rapid Load Test.

1. Preparation for testing as described in Section 3.0.
2. Place the piston mounting plate on the center of the test shaft, level the plate and secure with anchor bolts or welding.
3. Survey and record the shaft top elevation to a bench mark.
4. Bolt the piston assembly to the piston mounting plate.
5. Set the base frame for the gravel containment structure.
6. Connect load cell cable, ignition cable, and accelerometers to piston.
7. Connect all instrumentation to the data acquisition system.
8. Install the predetermined propellant fuel charge. Check the ignition initiating circuit for the correct resistance.
9. Install vent pin with new seal. Grease piston and cylinder. Place cylinder over piston.
10. Place reaction masses. Secure the masses to the cylinder assembly.
11. Place the gravel containment structure and secure into position (if required).
12. Fill the annular space between the gravel containment structure and the Rapid Load Test apparatus using gravel (if required).
13. Check the assembled device to ensure there is no physical interference of the load or acceleration monitoring systems.
14. Clear the test work area of personnel.
15. Perform final check of instrumentation and recording equipment.
16. Perform the test.
17. Back up test data on hard drive or jump drive.

5.0 INSTRUMENTATION

The intent of the load test instrumentation is to measure the test load and its distribution between side friction and end bearing, load versus deflection, to provide information for design calculations and estimates, and to provide information for final design. The Contractor shall provide assistance when requested by the Rapid Load Test supplier during installation

EXHIBIT 5 – SPECIAL PROVISIONS

of any instrumentation supplied through this contract. The Contractor should be aware that lead times are required for ordering instrumentation. The Contractor shall take the lead times into account when planning the work. The instrumentation shall be installed prior to the construction or installation of the test drilled shaft.

The cost of all instrumentation, to be installed as directed by the Rapid Load Test supplier, shall be included in the cost for Rapid Load Testing. Instrumentation pertaining to the Rapid Load Testing, and listed below, shall be provided by the Rapid Load Test supplier.

1. Electronic Resistance Based Strain Gages – See plans for layout and location of electronic resistance based strain gages. Lead wire shall not be unspliced.
2. Accelerometers – A total of 3 accelerometers shall be arranged across the top of the test shaft approximately 120 degrees apart during Rapid Load Testing.
3. Data Acquisition System – The resistance strain gages will require specialized equipment capable of digitizing at very fast rates. The Rapid Load Test supplier shall supply the necessary equipment and record the test data.

6.0 REPORTING OF RESULTS

The final report of Rapid Load Testing is due no later than 14 days after all Rapid Load Testing is completed and accepted by the Department. Field results of the Rapid Load Test will be provided within 72 hours of test completion.

7.0 METHOD OF MEASUREMENT

The quantity of the pay item “Rapid Load Test of Drilled Shafts” is measured by each (EA) completed and accepted by the Department. A completed Rapid Load Test shall be 1 test conducted on a test drilled shaft using the Rapid Load Test method, and meeting +/- 15 percent of, or exceeding the target test peak load as specified in the plans and Special Provisions.

The Rapid Load Test shall be considered as any material, labor, equipment, instrumentation, etc. required above and including the requirements of test drilled shaft installation. This item should include everything necessary to assemble, install, perform, collect data, and remove the Rapid Load Test equipment; under the direction of the Rapid Load Test supplier and others.

All costs associated with the normal production of the drilled shaft are measured and paid for elsewhere in the contract documents.

8.0 DISPOSITION OF TEST SHAFT

After all testing and data collection has been completed, the test drilled shaft shall be cut off to a minimum depth of 2 feet below the ground surface. The cut-off portion of the shaft shall be properly disposed of by the contractor and the resulting hole shall be backfilled with soil in accordance with Section 205 of the Standard Specifications. The test area shall be graded smooth. In addition, the location of this test drilled shaft shall be indicated on the As-Built plans for this project.

9.0 BASIS OF PAYMENT

Rapid Load Testing will be paid for at the contract bid price per each accepted test. The price and payment shall be considered full compensation for furnishing all materials, providing all tools, equipment, labor and incidentals, providing assistance to the production of the test shaft, performing the Rapid Load Test, and disposing of the test drilled shaft as described in Section 8.0 above.

10.0 PAYMENT

Payment shall be made under SCDOT Pay Item No. 7120600, "Bi-Directional Static Load Testing of Drilled Shafts."

(65) SECTION 712: HIGH STRAIN DYNAMIC LOAD TESTING OF DRILLED SHAFTS:

July 20, 2015 April 14, 2015

1.0 GENERAL

This work shall consist of performing High-Strain Dynamic Load Testing using a drop weight loading system on a test drilled shaft for the purpose of determining and/or verifying the nominal bearing resistance that may be used in the design of production drilled shafts. In addition, the structural integrity of the test drilled shaft, the load-deflection and soil-load transfer relationships shall also be determined. Production drilled shaft lengths may be adjusted after results of the test drilled shaft have been analyzed. No materials shall be ordered until drilled shaft lengths are approved by the Department. The test shaft depth, diameter, and location shall be as specified in the plans. The testing specified in the project documents shall be conducted in general accordance with ASTM D4945 – *Standard Test Method for High-Strain Dynamic Testing of Deep Foundations* and this **Supplemental Technical Specification Special Provision**.

The drop weight load testing equipment shall have sufficient capacity to fully mobilize the test shafts' nominal bearing resistance shown in the plans. ~~The applied load shall at least be equivalent to the test drilled shaft load specified in the plans, if greater than the nominal bearing resistance.~~

The location of the test drilled shaft (non-production) shall be as indicated in the plans. The test drilled shaft shall maintain a minimum distance of 25 feet from any foundation element of any future bent. The Contractor shall submit the proposed location to the Department for approval.

Load testing of the test drilled shaft shall not begin until the concrete has attained a compressive strength (f'_c) as indicated in the plans and had a curing time of no less than 7 days. High early strength concrete may be used to obtain the required strength at an earlier time to prevent testing delays, upon the approval of the Department.

The Contractor will be required to furnish and include all costs in the bid item for all materials, personnel, and equipment as described in the plans, this **Supplemental Technical Specification**, the Special Provisions and as required by the contract to adequately perform High Strain Dynamic Load Testing of Drilled Shafts. The Contractor shall engage the services of an approved High Strain Dynamic Load Test supplier for instrumenting, performing, and reporting of the high strain dynamic load test. The Contractor may contact the Engineer for names of High Strain Dynamic Load Test suppliers.

The Contractor shall supply the name and qualifications of the selected High Strain Dynamic Load Test supplier a minimum of 30 days prior to conducting the High Strain Dynamic Load Test. The Contractor shall submit to the Department for approval 3 sets of shop drawings, erection plans, and test calculations and details. The Contractor should include details with respect to the movement measuring system and the method for measuring the applied load. The Contractor shall also submit details and shop drawings of the proposed set up for review by the Department 2 weeks prior to beginning construction of the testing arrangements (including the test drilled shaft). All details, drawing calculations, and procedures shall be submitted to the Department for review a minimum of 2 weeks prior to beginning the High Strain Dynamic Load Testing. Approval of these submittals by the Department shall not relieve the Contractor from making subsequent changes that may become necessary to carry out the test.

The Contractor, in cooperation with the High Strain Dynamic Load Test supplier, shall supply and supervise the mobilization, assembly, and operation of the High Strain Dynamic Load Test equipment. The High Strain Dynamic Load Test supplier shall provide and install the required instrumentation for the test drilled shaft, acquire the test data during testing, and reduce the data into a report. This report shall be presented to the Contractor and the Department for evaluation. Interpretation of the test data with regard to foundation recommendations will be performed by the Department.

2.0 MATERIALS & EQUIPMENT

The Contractor shall supply all materials, personnel and equipment as described below and as required by the contract to adequately perform the High Strain Dynamic Load Test. Such materials and equipment are:

1. The High Strain Dynamic loading system and all items specifically incidental to the loading system.
2. Means to insure flat, level (axial to test shaft), and solid concrete shaft top.
3. A drop weight in the range of 1 to 2 percent of the anticipated drilled shaft nominal resistance no less than or 20 tons, whichever is lower or as specified in the plans. The impacting surface of the drop weight should have an area between 70 and 130 percent of the test shaft top area. The cross-sectional shape of the drop weight shall be as regular as possible (square, round, hexagonal, etc.).
4. A guiding frame allowing variable drop heights typically between 3 and 7 feet, or as determined by the High Strain Dynamic Load Testing Engineer (described herein as Testing Engineer) in consultation with the Department.
5. A top cushion consisting of new sheets of plywood with a total thickness of 2 to 6 inches, or as determined by the Testing Engineer in consultation with the Department.
6. A surveyor's transit, laser light or equivalent for measurements (precise to the nearest one-tenth inch) of test shaft set under each drop weight impact.
7. Dynamic testing shall be performed and/or supervised by a Licensed Professional Engineer in South Carolina with at least 2 years of dynamic testing experience.

The Contractor shall supply any additional equipment and personnel to assemble, perform, disassemble, and move to next test site (if applicable). This equipment includes, but not limited to, the following:

1. Unloading and loading of the High Strain Dynamic Load Test supplier trucks during mobilization and demobilization.
2. Any necessary on-site mobilization of test equipment.
3. A level and firm surface surrounding the test drilled shaft to support the High Strain Load testing system.
4. A level and smooth drilled shaft top. The top of the test drilled shaft shall incorporate permanent casing length as indicated in the plans and have a minimum ½-inch wall thickness. There shall be at least 6 inches between the top of the test drilled shaft and the top of the casing left in place.

EXHIBIT 5 – SPECIAL PROVISIONS

5. A crane, rigging and operator capable of lifting, unloading, assembling, disassembling, and packing all High Strain Dynamic Load Test equipment. The crane and rigging should be of sufficient size and strength to handle the required High Strain Load Test equipment.
6. Power source adequate for electronic equipment.
7. For over water tests only, welding equipment and welder for falsework platform.

3.0 PREPARATION FOR TESTING

The Contractor shall perform site and foundation preparation. Foundation preparation includes the cutting and cleaning of the surface of the test drilled shaft down to test elevation. The top of the test drilled shaft shall be smooth and level. The area around the test drilled shaft, on land, shall be leveled and compacted within a 15-foot radius. The top of the drilled shaft should be approximately 1-1/2 diameters above grade for axial testing. For over water or elevated work areas, the area provided shall be level and at the test elevation. The support falsework platform shall be assembled and installed by the Contractor at the test location.

Prior to performing the load test, the Testing Engineer shall be provided with soil boring logs, test shaft installation records, concrete properties (strength, etc.) and details regarding the anticipated dynamic loading equipment. The Testing Engineer is required to perform wave equation analyses (using GRLWEAP or equivalent) to determine the suitability of the proposed dynamic load testing equipment and an acceptable range of drop weight heights so as not to cause damage in the test shaft during the test. ~~If High Strain Dynamic Load Test becomes necessary after the construction letting, then the Contractor shall provide notice of this requirement to the Department at least 45 days in advance of the test.~~

For the test drilled shaft, proposed instrumentation location shall be provided to the Department a minimum of 7 days prior to the fabrication of the drilled shaft reinforcement cage. The Department will provide comments for the final instrumentation locations within 3 days after receiving this information.

Strain and pressure gage instrumentation, displacement transducers, CSL access tubes, High Strain Dynamic Load Testing devices and any other materials and equipment required by High Strain Dynamic Load Test supplier shall be installed on the reinforcing cage.

Immediately prior to placement of the reinforcement cage, the dimensions and verticality of the drilled shaft excavation shall be determined by Contractor using a **sonic calibration** method approved by the Engineer.

CSL testing will be performed by the Department personnel or a Department designated representative in accordance with Section 727 of the Standard Specifications.

The Contractor shall perform the test drilled shaft excavation in accordance with Section 712 of the Standard Specifications.

The Contractor shall use the utmost care in handling the test assembly so as not to damage the instrumentation during installation. The Contractor shall limit the deflection of the cage to 2 feet between pick points while lifting the cage from the horizontal position to vertical. The maximum spacing between pick points shall be 25 feet. The Contractor shall provide support bracing, strong backs, etc. to maintain the deflection within the specified tolerance.

4.0 PROCEDURE FOR LOAD TESTING

The Contractor shall assist the Testing Engineer as necessary during all aspects of the High Strain Dynamic Load Test. The following steps shall be taken in the performance of the High Strain Dynamic Load Test.

EXHIBIT 5 – SPECIAL PROVISIONS

1. Preparation for testing as described in Section 3.0.
2. Prior to testing, the Contractor shall make the upper 1-1/2 diameters of the test shaft completely accessible to the Testing Engineer.
3. Four “windows” (approximate size of 6 by 6 inches) diametrically opposite of each other shall be located and removed from the casing, if appropriate, or an entire band of the casing removed to expose a smooth concrete surface for attachment of the sensors. Sensors are typically attached at least 1 diameter below the shaft top. Sensor locations will be determined by the Testing Engineer.
4. In areas where casing is not present, the Testing Engineer, or Contractor under the direction of the Testing Engineer, shall smooth (by grinding) areas around the test shaft circumference such that proper sensor attachment can be accomplished.
5. Sensors shall be attached by the Testing Engineer or under the direction of the Testing Engineer to the exposed concrete in a secure manner as to prevent slippage under impact.
6. Shaft top should be examined to insure having a smooth level surface.
7. Survey and record the shaft top elevation to a bench mark.
8. Apply plywood cushion and striker plate to the shaft top.
9. Two to four hammer impacts with varying drop heights should be applied to the top of the shaft. The first drop height should be minimal to allow the Testing Engineer to assess the testing equipment, the driving system and stresses on the shaft. Subsequent impacts can then be applied by utilizing sequentially higher drop heights until either stresses in the shaft are excessive or the shaft permanent set for the applied impact exceeds 0.1 inch.

5.0 INSTRUMENTATION

The intent of the load test instrumentation is to measure the test load and its distribution between side friction and end bearing, load versus deflection, to provide information for design calculations and estimates, and to provide information for final design. The Contractor shall provide assistance when requested by the Testing Engineer during installation of any instrumentation supplied through this contract.

The cost of all instrumentation, to be installed as directed by the High Strain Dynamic Load Test supplier, shall be included in the cost for High Strain Dynamic Load Testing. Instrumentation pertaining to the High Strain Dynamic Load Testing, and listed below, shall be provided by the High Strain Dynamic Load Test supplier in addition to any instrumentation outlined in ASTM D4945.

1. Pile Driving Analyzer[®] (PDA) manufactured by Pile Dynamics, Inc., model PAK, PAX or PAL or equivalent.
2. Four calibrated strain transducers.
3. Four calibrated accelerometers.

6.0 REPORTING OF RESULTS

It is the High Strain Dynamic Load Test supplier's responsibility to submit a Final Report of

the High Strain Dynamic Load Testing no later than 14 days after all High Strain Dynamic Load Testing is completed and accepted by the Department. Field results of the High Strain Dynamic Load Test shall be provided within 72 hours of test completion. In addition to the field results, results from a CAPWAP[®] analysis or equivalent shall be submitted. A CAPWAP[®] analysis shall be completed for each hammer impact in the field and shall be performed by an Engineer that has achieved Advanced Level or better on the Foundation QC High Strain Dynamic Pile Testing Examination. The report must also provide the following:

1. Wave Equation analysis results obtained prior to testing.
2. CAPWAP[®] (or equivalent) analysis results.
3. The maximum measured force, maximum calculated tension force, transferred energy to the sensor location, corresponding stresses, and the Case Method bearing capacity for each impact.
4. Assessment of the test results both with respect to shaft capacity (including end bearing and friction resistance) and integrity.

7.0 METHOD OF MEASUREMENT

The quantity of the pay item “High Strain Dynamic Load Testing of Drilled Shafts” is measured by each (EA) completed and accepted by the Department. A completed High Strain Dynamic Load Test shall be 1 test conducted on a test drilled shaft using the High Strain Dynamic Load Testing System and meeting +/- 15 percent of, or exceeding the target test peak load as specified in the plans.

The High Strain Dynamic Load Test shall be considered as any material, labor, equipment, instrumentation, etc. required above. This item should include everything necessary to assemble, install, perform, collect data, and remove the High Strain Dynamic Load Test equipment; under the direction of the High Strain Dynamic Load Test supplier and others.

All costs associated with the normal production of the drilled shaft are measured and paid for elsewhere in the contract documents.

8.0 DISPOSITION OF TEST SHAFT

After all testing and data collection has been completed, the test drilled shaft shall be cut off to a minimum depth of 2 feet below the ground surface. The cut-off portion of the shaft shall be properly disposed of by the contractor and the resulting hole shall be backfilled with soil in accordance with Section 205 of the Standard Specifications. The test area shall be graded smooth. In addition, the location of this test drilled shaft shall be indicated on the As-Built plans for this project.

9.0 BASIS OF PAYMENT

High Strain Dynamic Load Testing will be paid for at the contract bid price per each accepted test. The price and payment shall be considered full compensation for furnishing all materials, providing all tools, equipment, labor and incidentals, providing assistance to the production of the test shaft, performing the High Strain Dynamic Load Test, and disposing of the test shaft as described in Section 8.0 above.

10.0 PAYMENT

Payment shall be made under SCDOT Pay Item No. 7120800, “Bi-Directional Static Load Testing of Drilled Shafts.”

(66) SECTION 714: SMOOTH WALL PIPE:

REFERENCE:**SCDOT Supplemental Technical Specification SC-M-714****DESCRIPTION:**

When bid items for smooth wall pipe are listed in the EBS file and/or proposal, the SCDOT will allow the use of reinforced concrete pipe, spiral ribbed aluminum pipe or high density polyethylene pipe in accordance with the specifications found in SC-M-714 (latest edition), the Standard Drawings, and this Special Provision. The plans may indicate reinforced concrete pipe only and are hereby superseded by this Special Provision.

MATERIALS:

Smooth wall pipe is either Reinforced Concrete Pipe (RCP: 714-205-XX), Spiral Ribbed Aluminum Pipe (SRAP: 714-605-XX), or High Density Polyethylene pipe (HDPE: 714-705-XX) as described in SCDOT Supplemental Technical Specification SC-M-714 and in the SCDOT Standard Drawings. Use smooth wall pipe culvert from manufacturers listed on Qualified Product Lists 30, 68, or 69. No value engineering application is required in order to use alternate pipe.

For the following counties: Berkeley, Beaufort, Charleston, Colleton, Dorchester, Georgetown, Horry, and Jasper, provide pipe joints meeting AASHTO M 315 for RCP or passing the 13 psi pressure test as indicated on the QPL for SRAP or HDPE. Take care to properly lubricate and equalize pipe gaskets as indicated in the **SCDOT Standard Drawings** and **SC-M-714** to prevent gaskets from “rolling” during installation. For all other counties, provide pipe joints meeting AASHTO M 198, M 315, or passing the minimum 10 psi pressure test unless specific pipe joints are indicated in the plans or special provisions.

No other pipe type will be accepted as an alternate.

CONSTRUCTION REQUIREMENTS:

Use only pipe that conforms to the minimum and maximum fill height limitations indicated on the appropriate standard drawing. Unless indicated otherwise in the plans, determine pipe fill height based on the following formula:

Fill Height = Elevation (top of curb or max grade above pipe) – Elevation (pipe crown)

For all locations where new pipe is being attached to an existing system, use one of the following options:

1. Any existing pipe may be extended using any acceptable alternate pipe type by using a drainage structure at the interface between the different pipe types. The drainage structure* may consist of standard junction boxes, manholes, catch basins, drop inlets, or circular drainage structures detailed on **SCDOT Standard Drawings**. For larger diameter pipe, custom drainage structures may be required. Field cut existing pipe to remove damaged joint (if applicable) and install new drainage structure at the field cut interface. Always fully clean existing pipe and pipe joints before installing joint sealant or gaskets and attaching new pipe.
2. For locations where existing pipe properties cannot be directly matched, use a custom designed interface* (concrete collar, proprietary mastic wrap, custom coupling band, etc.) appropriate to interface the existing pipe to the new pipe of the same type. Submit interface drawings and design for review by the Engineer of Record and the Design Standards Engineer. Always fully clean existing pipe and pipe joints before installing joint sealant or gaskets and attaching new pipe. Replace existing pipe that has joint damage before connecting new pipe to the system.

EXHIBIT 5 – SPECIAL PROVISIONS

3. Any existing pipe may be extended using new pipe with the same joint profile and wall properties of the existing pipe. Always fully clean existing pipe and pipe joints before installing joint sealant or gaskets and attaching new pipe. Verify* the following parameters before ordering new pipe:
 - a. For RCP to RCP, confirm wall thickness, joint profile shape, and compatibility with existing manufacturer’s pipe. Replace existing pipe that has joint damage before connecting new pipe to the system.
 - b. For SRAP to SRAP, replace existing pipe that has joint damage before connecting new pipe to the system.
 - c. For HDPE to HDPE, confirm the manufacturer of the existing pipe and the joint compatibility with the new pipe. Provide a new gasket when connecting to existing spigot end of HDPE pipe. Replace existing pipe that has joint damage before connecting new pipe to the system.
 - d. For CAAP to CAAP, confirm the type and size of end corrugations of the pipe. When existing pipe has full helical corrugations, provide new connecting pipe with one end fully helical and fully helical coupling band. When end corrugation size does not match the corrugation size shown on SCDOT Standard Drawings, provide a drainage structure (described above) at the interface. Replace existing pipe that has joint damage before connecting new pipe to the system. Do not install CAAP as smooth wall pipe; however, use these requirements when plans specify installing new CAAP.

The **RCE** will verify that connections between existing pipe and new installed pipe have been handled with one of the options listed above. Repair or replace all existing to new joint interfaces that do not meet the requirements above at no additional cost to **SCDOT**.

In all installations, provide the RCE with a complete pipe table indicating the following: Plan Pay Item, Plan Pipe Description, Plan Quantity, Installed Pipe (diameter, type, class/gage), Installed Quantity, and description of interface used to join new pipe to existing pipe for each occurrence.

In cases where 2 or more different pipe types are installed, provide a copy of the proposed installation layout on the drainage/plan sheets to the RCE indicating which pipe is installed at each location.

MEASUREMENT:

Measure smooth wall pipe in accordance with methods specified in SC-M-714 for the pipe material installed.

*No measurement will be made for drainage structure, designed interface, or field verification performed at each interface between existing pipe and new pipe unless drainage structure/interface is specified in the plans.

PAYMENT:

Payment will be made for smooth wall pipe regardless of the type of material installed. Payment for smooth wall pipe is as specified in SC-M-714 for the pipe material installed.

*Include all costs for work related to connecting new pipe to existing pipe in the unit bid price of the new pipe. This connection work includes: drainage structure at the interface, custom designed interface, field verification of existing pipe and compatibility with new pipe, new gaskets, new joint sealant, new coupling bands, removal, and disposal of damaged sections of existing pipe.

ITEM NO.	DESCRIPTION	UNIT
----------	-------------	------

EXHIBIT 5 – SPECIAL PROVISIONS

7143XXX	X" SMOOTH WALL PIPE	LF
7143XXX	X" x X" SMOOTH WALL PIPE CUL.TEE	EA
714XXXX	X" x X" SMOOTH WALL PIPE CUL.WYE	EA
7144XXX	X" SMOOTH WALL PIPE X DEG BEND	EA
7144XXX	SMOOTH WALL PIPE INCR.- X" TO X"	EA

(67) SECTION 714: PIPE END TREATMENTS (2/5/2010):

REFERENCE: SCDOT Supplemental Technical Specification SC-M-714

DESCRIPTION:

For exposed pipe culvert ends, provide an end treatment in accordance with this special provision.

MATERIALS:

Rigid pipe culvert is Reinforced Concrete Pipe (RCP: 714-205-00). Flexible pipe culvert is either Spiral Ribbed Aluminum Pipe (SRAP: 714-610-00), High Density Polyethylene pipe (HDPE: 714-705-00), or Corrugated Aluminum Alloy Pipe (CAAP: 714-605-00).

Use minimum Class B riprap for pipe up to 84" diameter. Use minimum Class C riprap for pipe 84" diameter or larger.

Use minimum Class 4000 concrete (4000P for precast).

Use ASTM A-706 grade 60, low-alloy steel deformed rebar.

Use minimum AASHTO M-196 Alclad 3004-H32 alloy aluminum.

Use Type M Mortar Grout unless specified otherwise.

CONSTRUCTION REQUIREMENTS:

Use one of the following end treatments as specified in the plans or special provisions:



For all exposed crossline pipe ends, when an end treatment is not specified in the plans, use **Pipe Riprap Protection** (804-3xx-xx). For flexible pipe larger than 24" diameter, install pipe straight headwall, pipe end structure, flared end section, or wingwall section in addition to riprap. For all exposed driveway pipe ends where no end treatment is specified in the plans, use **Pipe Riprap Protection** (804-3xx-xx) unless directed otherwise by the engineer.

EXHIBIT 5 – SPECIAL PROVISIONS



Use **Beveling of Pipe End** (719-610-00) when specified in the plans or special provisions. Beveled ends may only be used on flexible pipe up to 24" diameter and on rigid pipe up to 60" diameter. When beveling of pipe ends is specified on flexible pipe larger than 24" diameter, install pipe straight headwall, pipe end structure, flared end section, or wingwall section. Use factory fabricated beveled ends for all pipe types unless approved by the Engineer.



Use **Pipe Straight Headwall** (719-605-00) when specified in the plans or special provisions. Use straight headwall only in locations where pipe exposed end does not face the direction of traffic.



Use **Pipe End Structure** (719-615-00) when specified in the plans or special provisions. Use pipe end structure in locations where pipe exposed end faces the direction of traffic. Pipe end structures may be used in other locations if approved by the RCE.

EXHIBIT 5 – SPECIAL PROVISIONS



Use **Pipe Flared End Section** when specified in the plans or special provisions.



Use **Pipe Wingwall Section** when specified in the plans or special provisions.

Completely seal interface between pipe and end treatment with grout. If bricks or shims are used to place pipe, take care to remove all air pockets and voids when grouting.

For systems not designed in the SCDOT Standard Drawings, provide shop drawings, installation procedure and design calculations for review by RCE. Design must include provision to control erosion around the structure and prevent the separation of the end treatment from the pipe system. Design must provide for a proper seal at all construction joints including the interface between the pipe and the structure. Design must be self-supporting and not induce any additional loads on the pipe. Submit designs for consideration as new standard drawings to the Design Standards Engineer at the address listed in the SCDOT Standard Drawings book.

MEASUREMENT:

Measure pipe in accordance with SC-M-714

Measure end treatments in accordance with Standard Specifications, Standard Drawings, or Special Provisions.

PAYMENT:

Beveling of pipe ends will be in addition to the standard pipe pay item. Payment for the item Beveling of Pipe Ends includes all labor required to factory (or field, if approved) fabricate a bevel on one end of pipe.

Pipe culvert and end treatments, measured as provided in **SC-M-714 Subsection x.4**, are paid for at the contract unit price for the respective items, which price and payment is compensation for furnishing all material, labor, equipment, tools including hauling and placing all pipe sections and materials, excavation of the entire standard trench, bedding, and pipe backfill as described in the measurement section (both structural and embankment backfill in this region), removal of existing pipe to be replaced, constructing pipe joints, removal of old end treatments, cleaning out

pipe, disposal of surplus materials, all visual inspection, and all incidentals necessary to complete the work.

Add the following paragraph to SC-M-714 subsections x.5:

Payment for riprap and geotextile for erosion control under riprap as measured in subsection x.4 includes all direct and indirect costs and expenses necessary to complete the work.

(68) SECTION 714: LINE EXISTING PIPE:

DESCRIPTION

Rehabilitate drainage pipe by installing a pipe liner in accordance with the requirements of this Section. The plans will indicate the location of the pipe to be rehabilitated, the material composition and the alternate liner types that may be used to rehabilitate the pipe, and the method of liner installation.

PRE-INSTALLATION REQUIREMENTS

Prior to installing the pipe liner, inspect the host pipe and ensure that it is clean, dry and stable. Inspect the host pipe by means of closed circuit television. Furnish all equipment necessary to inspect, remove silt and other debris, and dewater the host pipe to the satisfaction of the Engineer. Place flowable fill and make spot repairs as directed by the Engineer to maintain the stability of the host pipe.

INSTALLATION METHODS

Install the liner using one of, or a combination of, the following methods: slip lining, inverting, pulling/pushing, spiral winding, coating, or bursting. Seal or grout the annular space between the interior of the host pipe and the exterior of the liner according to the liner manufacturer's written instructions.

- A. Slip Lining: Use either high density polyethylene or aluminum pipe liner. Install the liner by joining discrete lengths, panels or segments of the pipe liner in a manhole or other access point and inserting the liner into the host pipe.

Pulling/Pushing: Install the liner in accordance with the manufacturer's written instructions. Protect the pipe liner end using a device that uniformly distributes the applied load around the perimeter of the liner. Continuously monitor the applied load, and do not stretch the liner by more than 1% of its original length. For liner lengths of 100 feet or less, the end protection device may be omitted, with written permission from the Engineer. Do not seal the liner ends or begin grouting prior to 24 hours after liner installation.

High density polyethylene: Install high density polyethylene pipe liner in accordance with ASTM F 585. The manufacturer's written instructions may be substituted for ASTM F 585 with written permission from the Engineer.

Aluminum: Install aluminum pipe liner in accordance with the manufacturer's written instructions.

- B. Cured in Place: Install a resin impregnated felt tube pipe liner into the host pipe, and cure in place, in accordance with ASTM F 1216.
- C. Spiral Winding: Install the pipe liner in accordance with ASTM F 1698.
- D. Spray-On Coating: Use materials and install the pipe liner in accordance with the manufacturer's written instructions.

EXHIBIT 5 – SPECIAL PROVISIONS

- E. Pipe Bursting: Install the pipe liner in accordance with the manufacturer’s written instructions. Limit bursting to concrete crossdrain or sidedrain pipe having no lateral connections or risers. Further limit bursting to locations where no part of the host pipe passes within 5 feet of any buried utility or pavement base material.

ACCEPTANCE

Inspect the complete rehabilitation by means of closed circuit television Provide the Engineer with videos of all preliminary and final inspections.

METHOD OF MEASUREMENT

The quantity of pipe liner to be paid for will be the length, per foot, of pipe liner installed and accepted, measured along the centerline of the pipe, from end to end.

BASIS OF PAYMENT

Price and payment for pipe liner will be full compensation for furnishing and installing the pipe liner in accordance with the requirements of this Section, including all materials, labor and incidentals required for sealing cracks and joints in the existing pipe, and sealing and grouting the annular space between the liner and interior of the host pipe.

Price and payment for pipe liner will also be full compensation for all equipment, materials and labor required for inspections, and for furnishing videos of the inspections to the Engineer.

Item No.	Pay Item	Pay Unit
7149971	LINE EXISTING 12" PIPE	LF
7149972	LINE EXISTING 15" PIPE	LF
7149973	LINE EXISTING 18" PIPE	LF
7149974	LINE EXISTING 24" PIPE	LF
7149975	LINE EXISTING 30" PIPE	LF
7149976	LINE EXISTING 36" PIPE	LF
7149977	LINE EXISTING 42" PIPE	LF
7149978	LINE EXISTING 48" PIPE	LF
7149979	LINE EXISTING 54" PIPE	LF
7149980	LINE EXISTING 60" PIPE	LF
7149981	LINE EXISTING 66" PIPE	LF
7149982	LINE EXISTING 72" PIPE	LF
7149983	LINE EXISTING 78" PIPE	LF
7149984	LINE EXISTING 84" PIPE	LF

(69) SECTION 719: CAST IN PLACE CONCRETE PIPE COLLAR:

1.0 DESCRIPTION

A cast in place concrete pipe collar is used to provide a permanent connection between two pipe culverts of the same diameter but different joint profiles. Pipe collars can be used between two pipe of the same material or different material. Use only pipe that conforms to SC-M-714, Permanent Pipe Culverts.

2.0 MATERIAL

Use minimum class 4000 concrete.
Use reinforcement steel conforming to ASTM A706 Grade 60.
See SCDOT Standard Drawings or Project Plans for other material requirements and design details.

3.0 CONSTRUCTION REQUIREMENTS - GENERAL

Follow SCDOT Standard Drawings 719-705-xx for minimum dimensions and details. Use geotextile wrap on joint to minimize concrete intrusion into the joint during the forming and curing process.

4.0 MEASUREMENT

Measure concrete pipe collars by each location where pipe diameter of different joint profiles are to be connected. Include in measurement all materials and work to complete the pipe collar as shown in the Standard Drawings or plans.

5.0 PAYMENT

Payment will be made for each location.

Pay Items

7197051	CONCRETE COLLAR FOR UP TO 12" PIPE	EA
7197052	CONCRETE COLLAR FOR UP TO 24" PIPE	EA
7197053	CONCRETE COLLAR FOR UP TO 36" PIPE	EA
7197054	CONCRETE COLLAR FOR UP TO 48" PIPE	EA
7197055	CONCRETE COLLAR FOR UP TO 60" PIPE	EA
7197056	CONCRETE COLLAR FOR UP TO 72" PIPE	EA

(70) SECTION 726: PARTIAL DEPTH AND FULL DEPTH CONCRETE BRIDGE DECK REPAIR:

The Contractor's bid shall include 15 cubic yards of full depth concrete bridge deck repairs and 170 square yards of partial depth concrete bridge deck repairs within the overall project limits as directed by SCDOT. Any additional full depth concrete bridge deck repairs required by SCDOT in excess of the 15 cubic yards will be paid for at a unit price of **\$3,000.00/CY**. Any additional partial depth concrete bridge deck repairs required by SCDOT in excess of the 170 square yards will be paid for at a unit price of **\$350.00/SY**. If less than the estimated amounts above are required by SCDOT, the Contractor shall reimburse SCDOT for the quantity of deck repairs that were not needed. Reimbursement will be paid to SCDOT at a unit price of **\$3,000.00/CY** for full depth concrete bridge repair and **\$350.00/SY** for partial depth concrete bridge deck repairs.

Perform partial depth and full depth concrete repairs in all areas of unsound concrete designated by SCDOT. Perform partial depth deck repairs in accordance with Subsections 702.4.10.1 and 702.4.10.2 of the Standard Specifications. Perform full depth patching in accordance with Section 726 of the Standard Specifications.

After the repair concrete has been finished to the proper grade and just before the concrete becomes non-plastic, a transverse grooved surface finish shall be applied to match the transverse grooves in the surrounding deck. As the water sheen begins to disappear from the freshly screeded concrete, the tines shall be pulled across the surface of the concrete in a reasonably straight line in one continuous pass. The tines shall penetrate the surface of the concrete approximately 1/8 inch. A 1/2 inch to 1 inch gap shall be left between successive passes of the grooving device to eliminate weak surface areas inherent in overlapping grooves. Caution shall be taken to perform the tine finish at the proper time so that the grooves shall be relatively smooth and uniform and without unnecessarily tearing the surface of the concrete. The grooving device shall have square, circular, or rectangular shaped metal tines evenly spaced at 1/2 inch intervals. The tines shall produce transverse grooves in the concrete 0.08 to 0.13 inch in width.

Payment for all work required in accordance with Section 726 to include reinforcing steel, if required, will be made at the unit prices above.

(71) SECTION 727: CROSSHOLE SONIC LOGGING OF DRILLED SHAFT FOUNDATIONS:

Crosshole Sonic Logging (CSL) Testing is required for all drilled shafts. SCDOT shall be responsible for all CSL Testing.

EXHIBIT 5 – SPECIAL PROVISIONS

(72) SECTION 805: GEOTEXTILE FOR DRAINAGE FILTRATION:

October 15, 1991

I. ACCEPTANCE:

The Contractor shall supply to the Resident Engineer, prior to placing the material, certified test results from a recognized laboratory of those tests specified herein. Acceptance will be based on the test results meeting these requirements¹ and the material meeting all stated specifications. The Resident Engineer shall submit the certified test results to the Research and Material Engineer for acceptance. Test data shall be no more than 1 year old at the time it is furnished to the Department. Once a fabric has been accepted, it will be listed on an Approval Sheet, and only those materials listed will be acceptable. Test data must be resubmitted for reapproval every 2 years. No fabric will be used nor will payment be made for fabric until the fabric certification is received and approved by the Research and Materials Engineer. The Department reserves the right to sample and test any of the fabrics, or other materials used in drainage filtration, at any time.

II. PIPING RESISTANCE: (soil retention - all applications)

A. Soils with 50% or less particles by weight passing U.S. No. 200 sieve:

$$EOS \text{ No. (fabric)} \geq 30 \text{ U.S. Std. Sieve No.}$$

B. Soils with more than 50% particles by weight passing U.S. No. 200 sieve:

$$EOS \text{ No. (fabric)} \geq 50 \text{ U.S. Std. Sieve No.}$$

Note:

- a. Whenever possible, fabric with the lowest possible EOS No. should be specified.
- b. When the protected soil contains particles from 1 inch size to those passing the U.S. No. 200 sieve, use only the gradation of soil passing the U.S. No. 4 sieve in selecting the fabric.

III. PERMEABILITY:

$$\frac{\text{Critical/Severe Applications}^*}{k(\text{fabric}) \geq 10 k(\text{soil})^2} \qquad \frac{\text{Normal Applications}}{k(\text{Fabric}) \geq k(\text{soil})^2}$$

* Woven monofilament fabrics only; percent open area ≥ 4.0 and EOS No. ≤ 100 sieve.

IV. CHEMICAL COMPOSITION REQUIREMENTS/CONSIDERATIONS:

- A. Fibers used in the manufacture of civil engineering fabrics shall consist of long chain synthetic polymers, composed of at least 85% by weight of polyolefins, polyesters, or polyamides. These fabrics shall resist deterioration from ultraviolet exposure.
- B. The engineering fabric shall be exposed to ultraviolet radiation (sunlight) for no more than 30 days total in the period of time following manufacture until the fabric is covered with soil, rock, concrete, etc.

EXHIBIT 5 – SPECIAL PROVISIONS

V. PHYSICAL PROPERTY REQUIREMENTS (all fabrics)

	Class 1 Fabric ³ Protected	Class 2 Fabric ³ Unprotected
Grab Strength (ASTM D-4632 or ASTM D-1682)	80 lbs.	180 lbs.
Seam Strength ⁴ (ASTM D-4632 or ASTM D-1682)	70 lbs.	160 lbs.
Puncture Strength (ASTM D-3787)	25 lbs.	80 lbs.
Burst Strength (ASTM D-3786)	130 psi.	290 psi.
Trapezoid Team (ASTM D-4533)	25 lbs.	50 lbs.
Ultraviolet Degradation at 150 hours (ASTM D-4355)	70%	70%

¹ All numerical values represent minimum average roll values (i.e., any roll in a lot should meet or exceed the minimum values in the table). Use values for the weaker principal direction. Lots should be sampled according to ASTM D-4354.

² Permeability should be based on the actual fabric open area available for flow. For example, if 50% of the fabric area is to be covered by flat concrete blocks, the effective flow area is reduced by 50%.

³ Fabric is said to be protected when used in drainage trenches or beneath/behind concrete (Portland or asphalt cement) slabs. All other conditions are said to be unprotected,

Examples of each condition are:

Protected: highway edge drains, blanket drains, smooth stable trenches < 10 feet in depth. In trenches, in which the aggregate is extra sharp, additional puncture resistance may be necessary.

Unprotected: stabilization trenches, interceptor drains on cut slopes, rocky or caving trenches or smooth stable trenches > 10 feet in depth.

⁴ Values apply to both field and manufactured seams.

(73) SECTION 805: GEOCOMPOSITE WALL DRAIN:

May 6, 2003

1.0 DESCRIPTION

A geocomposite wall drain is a prefabricated drain system that is used to provide drainage behind retaining walls. The geocomposite drain consists of a flexible plastic drainage core bonded to a non woven geotextile. Geocomposite wall drains shall be placed continuously along the back of the wall as shown in the plans or as otherwise directed by the Engineer.

EXHIBIT 5 – SPECIAL PROVISIONS

The Contractor shall furnish all necessary labor, equipment, and materials and perform all operations necessary for the installation of geocomposite wall drains in accordance with the details shown on the plans and with the requirements of this specification.

2.0 ACCEPTANCE CRITERIA

The Contractor shall supply to the Engineer, prior to placing the material, certified test results of those tests specified herein from a recognized laboratory. Acceptance will be based on the test results meeting the geocomposite system properties, drainage core properties, and geotextile properties stated in this specification. The Engineer shall submit the certified test results to the Research and Material Engineer for acceptance. Test data shall be no more than one year old at the time it is furnished to the Department. Geocomposite wall drains shall not be installed until the material certification is received and approved by the Research and Materials Engineer. The Department reserves the right to sample and test any of the materials used in the geocomposite wall drain system.

Labeling, shipment, and storage of the geocomposite wall drain materials shall follow ASTM D 4837. Product labels shall clearly show the manufacturer or supplier name, style number, and roll number. Geocomposite rolls shall be wrapped with a material that will protect the geocomposite drain from damage due to shipment, water, sunlight, and contaminants. The protective wrapping shall be maintained during periods of shipment and storage.

3.0 MATERIAL

The geocomposite wall drain shall be prefabricated type made up of a lightweight, high impact polymeric drainage core bonded to the geotextile at intervals not exceeding 1.5 inches. The geocomposite wall drain shall be solid backed allowing drainage of water on only one side. The non woven geotextile is thermal (heat) bonded or fungicide glue bonded to the polymeric drainage core. The geocomposite product sheets or rolls shall have a minimum width of 3 feet with a minimum coverage area of 40 square feet. A geotextile flap shall be provided along all drainage core edges. This flap shall be of sufficient width for sealing the geocomposite drain edge to prevent soil intrusion into the drainage core during and after installation. The geotextile shall cover the full length of the drainage core.

The wall drainage system shall meet the following geocomposite system properties in addition to the individual component properties of the polymeric drainage core and the non woven geotextile. All numerical values listed in the required property tables shown below represent minimum average roll values (MARV) per ASTM D 4759 unless indicated otherwise. Values for the weaker principal direction should be used. Testing shall be performed in accordance with the methods referenced in this specification. Sampling of lots shall be in accordance with ASTM D 4354.

GEOCOMPOSITE SYSTEM PROPERTIES		
TEST	METHOD	LIMIT
Flow Capacity (gpm/ft. width) At a hydraulic gradient of 1.0 and a minimum normal stress of 3600 psf (Normal load maintained for 300 hours or until equilibrium)	ASTM D 4716	14

EXHIBIT 5 – SPECIAL PROVISIONS

DRAINAGE CORE PROPERTIES		
TEST	METHOD	LIMIT
Thickness (inches)	ASTM D 1777	0.3 minimum / 0.5 maximum
Compressive Strength (psf) At 20% Deformation (10,000 hour minimum duration)	ASTM D 1621	14,000

GEOTEXTILE PROPERTIES		
TEST	METHOD	LIMIT
AOS (Equiv. U.S. Sieve)	ASTM D 4751	50 maximum average roll value
Permittivity (sec ⁻¹)	ASTM D 4991	1.0
Grab Tensile Strength (lbs.)	ASTM D 4632	80
Grab Tensile Elongation (%)	ASTM D 4632	50
Trapezoidal Tear Strength (lbs.)	ASTM D 4533	40
Puncture Strength (lbs.)	ASTM D 4833	50
Burst Strength (psi)	ASTM D 3786	150
Ultraviolet Stability (%) (Retained strength after 500 hours of exposure)	ASTM D 4355	70

4.0 CONSTRUCTION REQUIREMENTS - GENERAL

The Contractor shall check the geocomposite wall drain upon delivery to ensure that the proper material has been received. The geocomposite wall drain shall be protected during shipment and storage at the construction site from temperatures greater than 71° C, mud, dirt, debris, and any other environmental condition that may damage the material's physical property values. The wall drainage system shall be protected from direct sunlight in accordance with the manufacturer's recommendations.

The geocomposite wall drain will be rejected at the time of installation if it has defects, tears, punctures, flaws, deterioration, or damage incurred during manufacture, shipment, or storage. Torn or punctured sections shall be removed or repaired as directed by the Engineer. Any geocomposite wall drain damaged during manufacture, shipment, or storage shall be replaced by the Contractor at no additional cost.

If at any time the Engineer determines that the method of installation does not produce a satisfactory wall drainage system, the Contractor shall alter his method and/or equipment as necessary to comply with this specification.

The geocomposite wall drain shall be installed in accordance with the plans and specifications. The surface that the geocomposite drain will be placed against shall be cleaned by removing all soil, debris, and irregularities that will prevent intimate contact between the surface and the geocomposite drain. The geocomposite wall drain shall be secured to the wall using metal stick clips, adhesives, or as recommended by the manufacturer. The geocomposite wall drain shall be installed so as to allow weepholes, as shown in the plans, to drain water from the drainage core and underdrain pipes.

All joints shall be formed by peeling or trimming the geotextile off the attached section to expose 3 inches of the drainage core. The drainage core of the second section being attached is then overlapped 2 inches over the first drainage core. The joint is then covered by reattaching the geotextile flap and securely fastening it to the lower geotextile by means of

a continuous strip of 3 inch wide waterproof plastic tape. Each overlapping course shall be shingled in the direction of water flow. If joints cannot be formed by interlocking the cuspatations, then the drainage core should be butted together and covered with continuous, 6 inch wide geotextile. The geotextile fabric shall be centered over the joint and securely fastened to the two geocomposite drains with 3 inch wide waterproof plastic tape.

All exposed edges of the geocomposite wall drain shall be covered with geotextile by tucking and securing a minimum of 4 inches of geotextile behind the drainage core. This may be done by using the geotextile flaps at the edges or using a 12 inch wide continuous strip in the same manner, taping it to the exposed fabric 4 inches in from the edge with a continuous strip of 3 inch wide waterproof plastic tape, and folding the remaining geotextile and tucking it behind the drainage core edge.

If the geotextile is torn, perforated, or ripped during installation, it shall be patched or replaced as directed by the Engineer. The damaged section shall be cut out and replaced completely or repaired by placing a piece of geotextile over the damaged area and providing a minimum of 4 inches of overlap on all sides over the damaged area and secured with 3 inch wide waterproof plastic tape. Damaged drainage core sections shall be discarded and replaced. Any geocomposite wall drain damaged during installation shall be replaced or repaired by the contractor at no additional cost.

The underdrain pipes and free draining aggregate shall be placed as shown in the plans or as directed by the Engineer. A positive outlet for the water in the geocomposite drain shall be maintained at all locations. Weepholes shall not be sealed or made ineffective by the wall drain material. This may involve making a hole in the drainage core at the weephole location. The geotextile drainage filtration fabric used to envelop the underdrain system shall be tucked 6 inches behind the geocomposite drain and overlapped over the geocomposite drain a distance of 12 inches and continuously secured with 3 inch wide waterproof plastic tape.

Backfill shall be placed immediately over the geocomposite wall drain. The contractor shall backfill against the wall in a manner that does not damage the geocomposite drainage system. Care shall be taken to avoid excessive settlement of the backfill material. The geocomposite wall drain shall not be exposed for more than seven days prior to backfilling. Any geocomposite drainage system component that is damaged during the backfilling operation shall be replaced or repaired as directed by the Engineer.

5.0 METHOD OF MEASUREMENT AND BASIS OF PAYMENT

Geocomposite wall drains will not be measured for payment. The cost of the geocomposite wall drain shall be included in the cost of the retaining wall or wall system where the drainage system is being installed.

(74) SECTION 805: THREAD LOCKING GUARDRAIL HARDWARE:

Use a permanent thread locking compound meeting Military Specification Mil-S-46163A Type I, Grade L. Follow the thread locking compound manufacturer's directions and apply compound to all the fasteners within Type T End Treatments, Impact Attenuators, and Crash Cushions. Apply compound to all guardrail fasteners across bridges or on base plate mounted posts, or in locations directed by the Resident.

(75) SECTION 805: TL3 TYPE T TANGENT END TERMINALS:

Qualified Product List 49 provides minimum length of continuous w-beam from the impact head for each proprietary Test Level 3 product. All radius, kinks, and transition sections must occur outside of the continuous w-beam section. SCDOT Standard Drawing 805-710-00 shows the required installation for systems with a 50' w-beam requirement. Where the design requires immediate transition from w-beam to thrie-beam at the end of the Type-T, confirm that adequate space exists in advance of the impact head before selecting a system that requires any length greater than 50'. The pay length for the TL3 Type T end terminal is shown in Special Provision

EXHIBIT 5 – SPECIAL PROVISIONS

Drawing 805-710-SP. No additional measurement or payment will be made for additional w-beam required by the selection of a proprietary product. Where sites do not accommodate longer end treatments, use a system with a 50' continuous w-beam section. When design includes a tangent installation of standard w-beam rail behind the 50' section, the designed rail will be measured and paid at 50' from the impact head as shown in the plan quantities.

For products with a 62'-6" requirement, see **attached** drawing 805-710-SP in **Attachment B** for additional guidance.

(76) SECTION 805: REPLACING DAMAGED GUARDRAIL:

Replace all moderately or severely damaged guardrail as defined in Engineering Directive 42.

(77) SECTION 805: RESETTING GUARDRAIL:

Existing steel beam guardrail that is determined to be in acceptable condition by the RCE, using the below criteria, may be reset in conformance with Section 805.4.3 of the 2007 SCDOT Standard Specifications. The Contractor shall inspect all guardrail on the project and notify the RCE in writing of any guardrail that will be permanently reset. Provide this notice to the RCE a minimum of two weeks prior to permanently resetting any guardrail on the project. Clean and regalvanize guardrail components prior to resetting in accordance with Section 805.4.3. If existing wood posts are planned to be reset, all existing wood posts shall be replaced with steel posts.

Resetting Guardrail Acceptance Criteria:

- Any guardrail components that are bent, flattened, torn, deformed, or damaged in any way shall not be reset.
- Guardrail with obsolete components and guardrail systems that are not on the SCDOT Qualified Products List (QPL) shall not be reset.
- Guardrail components with significant corrosion that affects performance or that cannot be fully cleaned for re-galvanizing shall not be reset.
- Section 805.4.3 disallows resetting guardrail posts. This shall only apply to existing wood posts.

(78) SECTION 805: GUARDRAIL POSTS:

Use steel posts with W-beam guardrail elements unless they are an integral part of an end treatment system.

(79) SECTION 806: REPAIR EXISTING CONTROL OF ACCESS FENCE:

Repair, replace or reset any damaged control of access fencing or fence components within the project limits, as directed by the RCE. Clear and remove from the project any vegetation or debris that has accumulated on the fences and either has damaged or is prohibiting the visual inspection of existing control of access fence. CONTRACTOR's bid shall include 500 linear feet of Repair of Existing Control of Access Fence. Should the actual length of fence rehabilitation vary from this estimated value by more than 25%, a change order will be generated by the RCE to adjust the contract value based on the actual rehabilitated length of fence as measured by SCDOT inspectors, utilizing a unit price of **\$15.00/LF**, regardless of fence type. Ensure all waste materials and debris generated during this work is disposed of promptly and at appropriate waste facilities.

(80) SECTION 815: EROSION CONTROL MEASURES:

In addition to the erosion control measures specified in the Plans, Standard Specifications, Supplemental Technical Specifications and the Special Provisions, the CONTRACTOR is advised that all land disturbing activities (clearing and grubbing, excavation, borrow and fill) are subject to the requirements set forth in the following permits and regulations:

EXHIBIT 5 – SPECIAL PROVISIONS

- South Carolina Code of Regulations 63-380, Standard Plan for Erosion, Sediment, and Stormwater Runoff Control.
- Erosion and Sediment Reduction Act of 1983 (Title 48, Chapter 18 of the South Carolina Code of Laws of 1983, as amended). Section 70 of this code authorized the South Carolina Department of Health and Environmental Control (SCDHEC) to administer this regulation with respect to lands under the jurisdiction of the South Carolina Department of Transportation.
- National Pollutant Discharge Elimination System (NPDES) General Permit Number SCR160000, effective January 1, 2013: The Environmental Protection Agency, in accordance with the Federal Clean Water Act, has granted to the South Carolina Department of Health and Environmental Control (SCDHEC) the authority to administer the Federal NPDES permit program in the State of South Carolina.

In accordance with the NPDES General Permit, the Contractor must sign a Contractor Certification. The certification is incorporated into the proposal form for the Contract. By signing this form, the Contractor acknowledges that upon award and execution of the Contract, he/she accepts/ understands the terms and conditions of the *Storm Water Pollution Prevention Plan (SWPPP)* as required by the NPDES General Permit and may be legally accountable to SCDHEC for compliance with the terms and conditions of the *SWPPP*. In addition, the Contractor certifies that the NPDES certification statement status is made part of all its subcontracts.

The Contractor will complete and forward an updated SCDOT approved *Notice of Intent (NOI)* to the SCDOT Construction office to submit to SCDHEC. If the Coastal Zone Consistency (CZC) permit has not been approved it shall be forwarded by the Contractor to SCDOT to submit to SCDHEC as part of *NOI* package. If SCDHEC does not send a letter within 10 business days of receipt of the *NOI*, authorizing coverage, denying coverage, or advising that a review of the *CECP* will take place, coverage will be automatically granted.

Prepare and submit a *Contractor's Erosion Control Plan (CECP)* to the RCE before the pre-construction conference. Ensure that the plan meets the requirements of the NPDES General Permit. The plan will be reviewed and approved by the Department before commencing any land disturbing activities.

At the pre-construction conference, with contractors performing land-disturbing activities present, the *CECP* will be explained and discussed so that the Contractor is made aware of their responsibilities in the *CECP*.

Once approved, fully implement the *CECP*. Coordinate the prompt installation of erosion control devices with construction activities to maintain compliance with the above regulations and NPDES General Permit.

Conduct an Erosion and Sediment Control Inspection by an appointed Certified Erosion Prevention and Sediment Control Inspector (CEPSCI) from the Contractor and the Department at least every 7-calendar days. Both parties will acknowledge participation in the inspection by signing the inspection report and include their inspector's CEPSCI number on the report. Correct deficiencies noted during these inspections within the assigned priority period. If deficiencies are not corrected within this timeframe, the RCE will stop all work (except erosion and sediment control measures) until the deficiencies are corrected.

Give special attention to critical areas within the project limits (i.e., running streams, water bodies, wetlands, etc.). In these areas, the RCE may direct the Contractor to undertake immediate corrective action, but in no case allow these deficiencies to remain unresolved more than 7 days or 48 hours in accordance with their assigned priority after being identified during the Erosion and Sediment Control Inspection.

EXHIBIT 5 – SPECIAL PROVISIONS

Closely follow the grading operations with the seeding operations. Shape and prepare the slopes for seeding as the grading progresses. Unless the RCE grants prior written approval, limit the amount of surface area exposed by land disturbing activities to 750,000 square feet. Commence seeding operations within 7 days following completion of construction activities within an area.

Initiate stabilization measures within 7 days for an area where construction activities will be temporarily or permanently ceased for 14 days or longer.

Coordinate the installation of all other permanent erosion control items with the grading and seeding operations. These items include, but are not limited to, asphalt gutter and riprap. Construct gutter work before or promptly after the seeding is performed. Place riprap at the ends of pipe immediately after the pipe is laid and promptly install riprap ditch checks after ditch work has been performed.

Failure to adequately comply with the provisions as detailed above or any other required erosion control measures will result in stoppage of all contract operations (except erosion and sediment control measures) until corrective action has been taken. Additional sanctions may be invoked by the SCDHEC in accordance with their authority.

Keep the following documents at the RCE's office from the start of construction until the site is finally stabilized:

- Copy of the *CECP*,
- Copies of Contractor Certification statements,
- Copy of the permit,
- Letter from DHEC authorizing permit coverage if provided by SCDHEC, and
- A marked-up set of site plans.

When uniform perennial vegetation achieves a cover density of 70%, submit a *Notice of Termination (NOT)* to SCDHEC to terminate coverage. Include a signed statement with the *NOT* certifying that all work on the site has been completed in accordance with the *SWPPP* and the NPDES General Permit for all sites one acre or greater.

Fines assessed on the Department by SCDHEC as the result of the CONTRACTOR's non-compliance or violation of said permit provisions will be paid by the Department and will subsequently be deducted from any monies due or that may become due to the CONTRACTOR. In case no monies are due or available, the fines incurred will be charged against the CONTRACTOR's Surety.

(81) SECTION 815: SAFETY FENCE:

Description

This work consists of furnishing materials, installing, and maintaining safety fence to mark all jurisdictional boundaries within a project corridor. Additionally where appropriate the contractor should hang highly visible flagging to outline the jurisdictional boundaries. The fence and flagging shall be installed prior to any land disturbing activities.

Materials

Polyethylene or polypropylene fence shall be an orange prefabricated safety fence approved by the Engineer. The fence shall be furnished with an ultraviolet coating and protected against moisture and extended ultra-violet exposure prior to placement. Either wood or steel posts may be used. Install safety fence using wooden stakes (1 inch x 1 inch) or steel posts (1.25 lbs/ linear foot) a minimum of five (5) feet in length.

Construction

No additional clearing and grubbing is anticipated for the installation of the safety fence. The fence shall be erected along and around the existing ground contour and vegetation.

Place survey stakes with high visibility flagging on 25' feet maximum intervals along the jurisdictional boundary. With the boundary established, install the orange safety fencing parallel to and offset 10 feet from the outside perimeter of all jurisdictional boundaries. The safety fence may be installed on a tangent that runs parallel to the buffer but must not encroach on the buffer at any location. Post shall be set on a maximum of 10 feet spacing.

Wetland flagging tape should be placed on adjacent vegetation to assist contractors in recognizing the jurisdictional boundaries.

The contractor shall maintain the safety fence in satisfactory condition for the duration of the project as determined by the RCE.

(82) SECTION 815: ANIONIC POLYACRYLAMIDE FOR EROSION CONTROL:

Description:

This work consists of applying a product containing anionic polyacrylamide to disturbed land areas as a means of controlling erosion. The work also consists of the use of solid form anionic polyacrylamide as a means of sediment control.

Materials:

The product to be used is to be specific to the area to be treated. Product selection and application rate is to be determined by a testing laboratory acceptable to SCDOT. Preliminary site-specific assessment (soil and water testing) by a qualified manufacturer must be conducted to select media, additives, application rate, application method and maintenance procedure tailored to site-specific soil characteristics, topography, hydrology, and the type of erosion targeted. A copy of the test results is to be provided to the Engineer.

Anionic polyacrylamide, in pure form, shall have less than or equal to 0.05% acrylamide monomer by weight, as established by the Food and Drug Administration and the Environmental Protection Agency. The maximum application rate of polyacrylamide, in pure form, shall not exceed 200 pounds/acre/year, or 10 pounds/acre per single application event.

The polyacrylamide shall have a charge density of 10% to 55%, by weight. The polyacrylamide shall have a molecular weight of 6 to 24 Mg/mole.

The polyacrylamide and polyacrylamide mixtures shall be noncombustible.

Cationic forms of polyacrylamide are not allowed for use due to their high level of toxicity.

Polyacrylamide shall be non-toxic. A toxicity report is required to be submitted to the Engineer.

Construction Requirements:

Liquid and powder forms of polyacrylamide are to be either applied directly to the exposed soil surface or applied as a tackifier with temporary seeding to prevent detachment of soil particles during the establishment of vegetation.

In the solid form, the polymer is to be placed directly into the storm water runoff to enhance eroded particle settlement in a trapping device.

Polyacrylamide shall be mixed and/or applied in accordance with all Occupational Safety and Health Administration (OSHA) Material Safety Data Sheet (MSDS) requirements and the

EXHIBIT 5 – SPECIAL PROVISIONS

manufacturer's recommendations for the specified use conforming to all federal, state and local laws, rules and regulations. The Contractor is responsible for obtaining all required permits.

Emulsion batches shall be mixed following recommendations of a testing laboratory that determines the proper product and rate to meet site requirements.

Additives such as fertilizers, solubility promoters, or inhibitors, etc. to polyacrylamide shall be nontoxic.

Care is to be taken when using polyacrylamide adjacent to natural water bodies.

Method of Measurement:

The application of polyacrylamide for erosion control will be measured by the surface area treated at the recommended rate of application. Quantities are to be computed to the nearest MSY (Thousand Square Yards). Solid form anionic polyacrylamide is to be measured by weight in pounds, in place and accepted. The Contractor is required to provide, to the Engineer, invoices for all polyacrylamide products used on the project.

Basis of Payment:

The accepted quantity of "Anionic Polyacrylamide For Erosion Control" will be paid at the contract unit price, which price and payment shall be full compensation for all materials, labor, tools equipment, and incidentals necessary to complete the work herein described in a workmanlike and acceptable manner. Solid form anionic polyacrylamide is to be paid for by the pound. Bid Item Numbers and Descriptions are as follows:

Bid Item Number	Description	Unit
8152020	Anionic Polyacrylamide for Erosion Control	MSY
8152025	Solid Form Anionic Polyacrylamide	LBS

EXHIBIT 6

FEDERAL-AID PROVISIONS

TABLE OF CONTENTS

APPLICATION OF DAVIS-BACON AND RELATED ACTS TO INDEPENDENT TRUCK DRIVERS AND MISCELLANEOUS CONSTRUCTION ACTIVITIES.....2

REQUIREMENTS FOR FEDERAL AID CONTRACTS WHICH AFFECT SUBCONTRACTORS, DBE HAULERS, MATERIAL SUPPLIERS AND VENDORS.....3

LATE DISCOVERY OF ARCHAEOLOGICAL/HISTORICAL REMAINS ON FEDERAL AID PROJECTS AND APPROVAL OF DESIGNATED BORROW PITS4

SPECIFIC EQUAL EMPLOYMENT OPPORUNITY RESPONSIBILITIES TRAINING SPECIAL PROVISIONS5

REQUIRED CONTRACT PROVISIONS FEDERAL AID CONSTRUCTION CONTRACTS.....7

STANDARD FEDERAL EQUAL EMPLOYMENT OPPORTUNITY CONSTRUCTION CONTRACT SPECIFICATIONS19

GENERAL DECISION NUMBER SC4222

DISADVANTAGED BUSINESS ENTERPRISES (DBE) COMMITTAL SHEET27

EXHIBIT 6 - FEDERAL AID PROVISIONS

June 13, 1990

APPLICATION OF DAVIS-BACON AND RELATED ACTS TO INDEPENDENT TRUCK DRIVERS AND MISCELLANEOUS CONSTRUCTION ACTIVITIES

The Davis-Bacon and Related Acts apply when:

- 1) A Contractor or Subcontractor hires a trucking firm or fleet of trucks to haul materials from a plant, pit, or quarry, which has been established specifically to serve (or nearly so) a particular project or projects covered by Davis-Bacon and Related Acts.
- 2) A Contractor or Subcontractor hires a trucking firm or fleet of trucks to haul material from a non-commercial stockpile or non-commercial storage site outside the limits of the project to the project site.
- 3) A Contractor or Subcontractor hires a trucking firm or fleet of trucks to haul excavated materials away from a Davis-Bacon covered project.
- 4) A contractor or Subcontractor rents or leases equipment with an operator to perform work as called for under a Davis-Bacon construction contract.
- 5) A common carrier is used for the transportation of materials from an exclusive material supply facility to fulfill the specific need of a construction contract.

The fleet owner is not considered a Subcontractor with regard to the 70% subcontracting limitations and would not have to be approved as a Subcontractor. However, payrolls must be submitted by truck fleet owner covering the truck drivers, and all requirements such as predetermined wages, overtime, etc., are applicable. Legitimate owner-operators (truck owner driving his own truck) must appear on the payroll by name and notation "truck Owner Operator" with no hours, etc. shown.

The Davis-Bacon and Related Acts do not apply when:

- 1) A Contractor or Subcontractor hires a trucking firm or fleet of trucks to haul materials from a commercial plant, pit, or quarry which had previously been established for commercial use and regularly sell materials to the general public.
- 2) A Contractor or Subcontractor hires a trucking firm or fleet of trucks to haul materials from an established commercial plant, pit, or quarry to a stockpile outside the limits of the project.
- 3) Bona fide owner-operators of trucks, who are independent contractors, use their own equipment to haul materials to or from or on a Davis-Bacon covered project. (One man-One truck)

The fleet owner is not considered a Subcontractor with regard to the 70% subcontracting limitation and would not have to be approved as a Subcontractor.

EXHIBIT 6 - FEDERAL AID PROVISIONS

March 1, 2010

**REQUIREMENTS FOR FEDERAL AID CONTRACTS WHICH AFFECT SUBCONTRACTORS, DBE
HAULERS, MATERIAL SUPPLIERS AND VENDORS**

- A. The contractor's attention is directed to the requirements of Section I.2 in Form FHWA 1273 that is included in your contract documents as the Supplemental Specification "Required Contract Provisions Federal-Aid Construction Contracts". Section I.2 requires that "the contractor shall insert in each subcontract all of the stipulations contained in the Required Contract Provisions". This requirement also applies to lower tier subcontractors or purchase orders. These provisions must be physically included in your subcontracts. A reference to the applicable specification will not suffice.
- B. The contractor's attention is directed to the requirements of the Supplemental Specification "Standard Federal Equal Employment Opportunity Construction Contract Specifications". Section 2 requires that the provisions of this specification must be physically included in each subcontract with a value of \$10,000 or greater.
- C. The contractor's attention is directed to the requirements of the Equal Employment Opportunity Performance certifications in the Proposal Form Certifications and Signatures section of the contract. Section 1 concerning Equal Employment Opportunity must be physically included in each subcontract.
- D. Prior to the issuance of formal approval, all DBE subcontracts must include a signed copy of the subcontract agreement between the Prime Contractor and the DBE Subcontractor.
- E. Prior to the issuance of formal approval, of any DBE haulers, the contractor must submit a signed copy of the hauling agreement.
- F. The contractor's attention is further directed that sections 1, 2, 3, 8, 9, and 11 of Form FHWA 1273, or Sections 1, 3, 8 and 10 of Form 1316 (for Appalachian contracts only) must be physically included in each purchase agreement with a value of \$10,000 or greater with a vendor or supplier, and in open-end contracts where individual purchases are less than \$10,000 but where the total purchases accumulate to \$100,000 or more per year.

August 7, 1991

LATE DISCOVERY OF ARCHAEOLOGICAL/HISTORICAL REMAINS ON FEDERAL AID PROJECTS AND APPROVAL OF DESIGNATED BORROW PITS

A. Late Discovery of Archaeological/Historical Remains on Federal Aid Projects.

1. Responsibilities:

The Contractor and subcontractors must notify their workers to watch for the presence of any prehistoric or historic remains, including but not limited to arrowheads, pottery, ceramics, flakes, bones, graves, gravestones, or brick concentrations. If any such cultural remains are encountered, the Resident Construction Engineer shall be immediately notified and all work in the vicinity of the discovered materials or site shall cease until the Department's Staff Archaeologist or the State Highway Engineer directs otherwise.

2. Applicability:

This provision covers all areas of ground disturbance resulting from this federal - aid contract, including but not limited to road construction, Department designated borrow pits, Contractor furnished borrow pits, and/or staging areas.

3. Cost Reimbursement and Time Delays:

Any extra work required by A(1) above within the project right of way or on Department designated borrow pits (see below) will be paid for in accordance with Subsection 104.05 of the Standard Specifications. Extra contract time may be provided under Subsection 108.06 of the Standard Specifications for archaeological work within the project right of way or on designated borrow pits.

NOTE: On Contractor furnished borrow pits the contractor is not entitled to any additional time or money for delay on impact resulting from A(1) above or for extra work required by A(1) above. Therefore, contractors may wish to retain professional archaeological services to better ensure that borrow pit areas are cleared of archaeological/historical remains prior to use on Federal aid projects.

B. Approval of Designated Borrow Pits on Federal Aid Projects (Plant Sites which qualify as commercial are not included).

In instances where the Department specifically designates the location of borrow pits on project plans or in contract specifications for use on a Federal aid project, an archaeological survey will be performed by Department archaeologists prior to award of contract.

This provision also applies to designated disposal sites, staging areas, haul roads, and job site field offices.

EXHIBIT 6 - FEDERAL AID PROVISIONS

August 20, 1975
Revised April 1, 2004

SPECIFIC EQUAL EMPLOYMENT OPPORTUNITY RESPONSIBILITIES
TRAINING SPECIAL PROVISIONS

This Training Special Provision supersedes Subparagraph 7b of the Special Provision entitled "Specific Equal Employment Opportunity Responsibilities", (Attachment 1), and is in implementation of 23 U.S.C. 140(a).

As part of the contractor's equal employment opportunity affirmative action program, training shall be provided as follows:

The contractor shall provide on-the-job training aimed at developing full journeymen in the type of trade or job classification involved.

THE NUMBER OF TRAINEES TO BE TRAINED UNDER THE SPECIAL PROVISION WILL BE.

Road – 4 (at 520 hours each).
Bridge – 1 (at 1040 hours each).

In the event that a Contractor subcontracts a portion of the contract work, he shall determine how many, if any, of the trainees are to be trained by the subcontractor, provided however, that the Contractor shall retain the primary responsibility for meeting the training requirements imposed by this Special Provision. The Contractor shall also insure that this training Special Provision is made applicable to such subcontract. Where feasible, 25 percent of apprentices or trainees in each occupation shall be in their first year of apprenticeship or training.

The number of trainees shall be distributed among the work classifications on the basis of the Contractor's needs and the availability of journeymen in the various classifications within a reasonable area of recruitment. Prior to commencing construction, the Contractor shall submit to the State Highway Agency for approval the number of trainees to be trained in each selected classification and training program to be used. Furthermore, the Contractor shall specify the starting time for training in each of the classifications. The Contractor will be credited for each trainee employed by him on the contract work who is currently enrolled or becomes enrolled in an approved program.

Training and upgrading of minorities and women toward journeyman status is a primary objective of this Training Special Provision. Accordingly, the Contractor shall make every effort to enroll minority trainees and women (e.g., by conducting systematic and direct recruitment through public and private sources likely to yield minority and women (trainees)) to the extent that such persons are available within a reasonable area of recruitment. The contractor will be responsible for demonstrating the steps that he has taken in pursuance thereof, prior to a determination as to whether the Contractor is in compliance with this Training Special Provision. This training commitment is not intended, and shall not be used, to discriminate against any applicant for training, whether a member of a minority group or not.

No employee shall be employed as a trainee in any classification in which he has successfully completed a training course leading to journeyman status or in which he has been employed as a journeyman. The Contractor should satisfy this requirement by including appropriate questions in the employee application or by other suitable means. Regardless of the method used the Contractor's records should document the findings in each case.

The minimum length and type of training for each classification will be as established in the training program selected by the Contractor and approved by the State Highway Agency and the Federal Highway Administration. The State Highway Agency and the Federal Highway Administration shall approve a program if it is reasonably calculated to meet the equal employment opportunity obligations of the Contractor and to qualify the average trainee for journeyman status in the classification concerned by the end of the training period. Furthermore, apprenticeship programs registered with the U.S. Department of Labor, Bureau of Apprenticeship and Training, or with a State apprenticeship agency recognized by the Bureau and training programs approved but not necessarily sponsored by the U.S. Department of Labor, Manpower Administration, Bureau of Apprenticeship and Training shall also be

EXHIBIT 6 - FEDERAL AID PROVISIONS

considered acceptable provided it is being administered in a manner consistent with the equal employment obligations of Federal Aid highway construction contracts. Approval or acceptance of a training program shall be obtained from the State prior to commencing work on the classification covered by the program. It is the intention of these provisions that training is to be provided in the construction crafts rather than clerk-typists or secretarial-type positions. Training is permissible in lower level management positions such as office engineers, estimators, timekeepers, etc., where the training is oriented toward construction applications. Training in the laborer classification may be permitted provided that significant and meaningful training is provided and approved by the division office. Some off-site training is permissible as long as the training is an integral part of an approved training program and does not comprise a significant part of the overall training.

Except as otherwise noted below, the cost for the training will be included in the contract price. There will be no reimbursement given by SCDOT for the hours of training that are provided on this project. However, a "Statement of Completed Training" will be required at the end of the project. The fact that the cost of the training must be included in the contract does not prohibit the contractor from receiving training program funds from other sources, if he so desires. Training hours may be counted if training is done off-site where the contractor does one or more of the following and the trainees are concurrently employed on a Federal Aid project: contributes to the cost of the training, provides the instruction to the trainee, or pays the trainee's wages during the off-site training period.

The training requirement will not be considered completed by the Contractor if either the failure to provide the required training, or the failure to hire the trainee as a journeyman, is caused by the Contractor and evidences a lack of good faith on the part of the Contractor in meeting the requirements of this Training Special Provision. It is normally expected that a trainee will begin his training on the project as soon as feasible after start of work the skill involved and remain on the project as long as training opportunities exist in his work classification or until he has completed his training program. It is not required that all trainees be on board for the entire length of the contract. A Contractor will have fulfilled his responsibilities under this Training Special Provision if he has provided acceptable training to the number of trainees specified. The number trained shall be determined on the basis of the total number enrolled on the contract for a significant period.

Trainees will be paid at least 60 percent of the appropriate minimum journeyman's rate specified in the contract for the first half of the training period, 75 percent for the third quarter of the training period, and 90 percent for the last quarter of the training period, unless apprentices or trainees in an approved existing program are enrolled as trainees on this project. In that case, the appropriate rates approved by the Departments of Labor or Transportation in connection with the existing program shall apply to all trainees being trained for the same classification who are covered by this Training Special Provision.

The Contractor shall furnish the trainee a copy of the program he will follow in providing the training. The Contractor shall provide each trainee with a certification showing the type and length of training satisfactorily completed.

The Contractor will provide for the maintenance of records and furnish periodic reports documenting his performance under this Training Special Provision, as required under the SCDOT approved training program.

Meeting the On-the-job Training Requirements or Making Good Faith Efforts to Meet the On-the-job Training Requirements. It is the Contractor's responsibility to meet the On-the-job Training Requirements stated in this section. Failure to meet the requirement or demonstrate good faith efforts, as determined by SCDOT, to meet the requirement may result in any one or more of the following sanctions:

- (1) Withholding monthly progress payments;
- (2) Declaring the Contractor in default pursuant to Section 108.10 of the Standard Specifications and terminating the contract;
- (3) Disqualifying the Contractor from bidding pursuant to Regulation 63-306, Volume 25A, of the S. C. Code of Laws; and/or
- (4) Requiring the Contractor to obtain On-the-job Training participation on future contracts to the extent the Contractor failed to meet or use good faith efforts to meet the On-the-job training contract requirement.

REQUIRED CONTRACT PROVISIONS FEDERAL-AID CONSTRUCTION CONTRACTS

- I. General
- II. Nondiscrimination
- III. Nonsegregated Facilities
- IV. Davis-Bacon and Related Act Provisions
- V. Contract Work Hours and Safety Standards Act Provisions
- VI. Subletting or Assigning the Contract
- VII. Safety: Accident Prevention
- VIII. False Statements Concerning Highway Projects
- IX. Implementation of Clean Air Act and Federal Water Pollution Control Act
- X. Compliance with Governmentwide Suspension and Debarment Requirements
- XI. Certification Regarding Use of Contract Funds for Lobbying

ATTACHMENTS

A. Employment and Materials Preference for Appalachian Development Highway System or Appalachian Local Access Road Contracts (included in Appalachian contracts only)

I. GENERAL

1. Form FHWA-1273 must be physically incorporated in each construction contract funded under Title 23 (excluding emergency contracts solely intended for debris removal). The contractor (or subcontractor) must insert this form in each subcontract and further require its inclusion in all lower tier subcontracts (excluding purchase orders, rental agreements and other agreements for supplies or services).

The applicable requirements of Form FHWA-1273 are incorporated by reference for work done under any purchase order, rental agreement or agreement for other services. The prime contractor shall be responsible for compliance by any subcontractor, lower-tier subcontractor or service provider.

Form FHWA-1273 must be included in all Federal-aid design-build contracts, in all subcontracts and in lower tier subcontracts (excluding subcontracts for design services, purchase orders, rental agreements and other agreements for supplies or services). The design-builder shall be responsible for compliance by any subcontractor, lower-tier subcontractor or service provider.

Contracting agencies may reference Form FHWA-1273 in bid proposal or request for proposal documents, however, the Form FHWA-1273 must be physically incorporated (not referenced) in all contracts, subcontracts and lower-tier subcontracts (excluding purchase orders, rental agreements and other agreements for supplies or services related to a construction contract).

2. Subject to the applicability criteria noted in the following sections, these contract provisions shall apply to all work performed on the contract by the contractor's own organization and with the assistance of workers under the contractor's immediate superintendence and to all work performed on the contract by piecework, station work, or by subcontract.

3. A breach of any of the stipulations contained in these Required Contract Provisions may be sufficient grounds for withholding of progress payments, withholding of final payment, termination of the contract, suspension / debarment or any other action determined to be appropriate by the contracting agency and FHWA.

4. Selection of Labor: During the performance of this contract, the contractor shall not use convict labor for any purpose within the

limits of a construction project on a Federal-aid highway unless it is labor performed by convicts who are on parole, supervised release, or probation. The term Federal-aid highway does not include roadways functionally classified as local roads or rural minor collectors.

II. NONDISCRIMINATION

The provisions of this section related to 23 CFR Part 230 are applicable to all Federal-aid construction contracts and to all related construction subcontracts of \$10,000 or more. The provisions of 23 CFR Part 230 are not applicable to material supply, engineering, or architectural service contracts.

In addition, the contractor and all subcontractors must comply with the following policies: Executive Order 11246, 41 CFR 60, 29 CFR 1625-1627, Title 23 USC Section 140, the Rehabilitation Act of 1973, as amended (29 USC 794), Title VI of the Civil Rights Act of 1964, as amended, and related regulations including 49 CFR Parts 21, 26 and 27; and 23 CFR Parts 200, 230, and 633.

The contractor and all subcontractors must comply with: the requirements of the Equal Opportunity Clause in 41 CFR 60-1.4(b) and, for all construction contracts exceeding \$10,000, the Standard Federal Equal Employment Opportunity Construction Contract Specifications in 41 CFR 60-4.3.

Note: The U.S. Department of Labor has exclusive authority to determine compliance with Executive Order 11246 and the policies of the Secretary of Labor including 41 CFR 60, and 29 CFR 1625-1627. The contracting agency and the FHWA have the authority and the responsibility to ensure compliance with Title 23 USC Section 140, the Rehabilitation Act of 1973, as amended (29 USC 794), and Title VI of the Civil Rights Act of 1964, as amended, and related regulations including 49 CFR Parts 21, 26 and 27; and 23 CFR Parts 200, 230, and 633.

The following provision is adopted from 23 CFR 230, Appendix A, with appropriate revisions to conform to the U.S. Department of Labor (US DOL) and FHWA requirements.

1. Equal Employment Opportunity: Equal employment opportunity (EEO) requirements not to discriminate and to take affirmative action to assure equal opportunity as set forth under laws, executive orders, rules, regulations (28 CFR 35, 29 CFR 1630, 29 CFR 1625-1627, 41 CFR 60 and 49 CFR 27) and orders of the Secretary of Labor as modified by the provisions prescribed herein, and imposed pursuant to 23 U.S.C. 140 shall constitute the EEO and specific affirmative action standards for the contractor's project activities under this contract. The provisions of the Americans with Disabilities Act of 1990 (42 U.S.C. 12101 et seq.) set forth under 28 CFR 35 and 29 CFR 1630 are incorporated by reference in this contract. In the execution of this contract, the contractor agrees to comply with the

EXHIBIT 6 - FEDERAL AID PROVISIONS

following minimum specific requirement activities of EEO:

a. The contractor will work with the contracting agency and the Federal Government to ensure that it has made every good faith effort to provide equal opportunity with respect to all of its terms and conditions of employment and in their review of activities under the contract.

b. The contractor will accept as its operating policy the following statement:

"It is the policy of this Company to assure that applicants are employed, and that employees are treated during employment, without regard to their race, religion, sex, color, national origin, age or disability. Such action shall include: employment, upgrading, demotion, or transfer; recruitment or recruitment advertising; layoff or termination; rates of pay or other forms of compensation; and selection for training, including apprenticeship, pre-apprenticeship, and/or on-the-job training."

2. EEO Officer: The contractor will designate and make known to the contracting officers an EEO Officer who will have the responsibility for and must be capable of effectively administering and promoting an active EEO program and who must be assigned adequate authority and responsibility to do so.

3. Dissemination of Policy: All members of the contractor's staff who are authorized to hire, supervise, promote, and discharge employees, or who recommend such action, or who are substantially involved in such action, will be made fully cognizant of, and will implement, the contractor's EEO policy and contractual responsibilities to provide EEO in each grade and classification of employment. To ensure that the above agreement will be met, the following actions will be taken as a minimum:

a. Periodic meetings of supervisory and personnel office employees will be conducted before the start of work and then not less often than once every six months, at which time the contractor's EEO policy and its implementation will be reviewed and explained. The meetings will be conducted by the EEO Officer.

b. All new supervisory or personnel office employees will be given a thorough indoctrination by the EEO Officer, covering all major aspects of the contractor's EEO obligations within thirty days following their reporting for duty with the contractor.

c. All personnel who are engaged in direct recruitment for the project will be instructed by the EEO Officer in the contractor's procedures for locating and hiring minorities and women.

d. Notices and posters setting forth the contractor's EEO policy will be placed in areas readily accessible to employees, applicants for employment and potential employees.

e. The contractor's EEO policy and the procedures to implement such policy will be brought to the attention of employees by means of meetings, employee handbooks, or other appropriate means.

4. Recruitment: When advertising for employees, the contractor will include in all advertisements for employees the notation: "An Equal Opportunity Employer." All such advertisements will be placed in publications having a large circulation among minorities and women in the area from which the project work force would normally be derived.

a. The contractor will, unless precluded by a valid bargaining agreement, conduct systematic and direct recruitment through public and private employee referral sources likely to yield qualified minorities and women. To meet this requirement, the contractor will identify sources of potential minority group employees, and establish with such identified sources procedures whereby minority and women applicants may be referred to the contractor for employment consideration.

b. In the event the contractor has a valid bargaining agreement providing for exclusive hiring hall referrals, the contractor is expected to observe the provisions of that agreement to the extent that the system meets the contractor's compliance with EEO contract provisions. Where implementation of such an agreement has the effect of discriminating against minorities or women, or obligates the contractor to do the same, such implementation violates Federal nondiscrimination provisions.

c. The contractor will encourage its present employees to refer minorities and women as applicants for employment. Information and procedures with regard to referring such applicants will be discussed with employees.

5. Personnel Actions: Wages, working conditions, and employee benefits shall be established and administered, and personnel actions of every type, including hiring, upgrading, promotion, transfer, demotion, layoff, and termination, shall be taken without regard to race, color, religion, sex, national origin, age or disability. The following procedures shall be followed:

a. The contractor will conduct periodic inspections of project sites to insure that working conditions and employee facilities do not indicate discriminatory treatment of project site personnel.

b. The contractor will periodically evaluate the spread of wages paid within each classification to determine any evidence of discriminatory wage practices.

c. The contractor will periodically review selected personnel actions in depth to determine whether there is evidence of discrimination. Where evidence is found, the contractor will promptly take corrective action. If the review indicates that the discrimination may extend beyond the actions reviewed, such corrective action shall include all affected persons.

d. The contractor will promptly investigate all complaints of alleged discrimination made to the contractor in connection with its obligations under this contract, will attempt to resolve such complaints, and will take appropriate corrective action within a reasonable time. If the investigation indicates that the discrimination may affect persons other than the complainant, such corrective action shall include such other persons. Upon completion of each investigation, the contractor will inform every complainant of all of their avenues of appeal.

6. Training and Promotion:

a. The contractor will assist in locating, qualifying, and increasing the skills of minorities and women who are applicants for employment or current employees. Such efforts should be aimed at developing full journey level status employees in the type of trade or job classification involved.

b. Consistent with the contractor's work force requirements and as permissible under Federal and State regulations, the contractor shall make full use of training programs, i.e., apprenticeship, and on-the-job training programs for the geographical area of contract performance. In the event a special provision for training is provided under this contract, this subparagraph will be superseded as indicated in

EXHIBIT 6 - FEDERAL AID PROVISIONS

the special provision. The contracting agency may reserve training positions for persons who receive welfare assistance in accordance with 23 U.S.C. 140(a).

c. The contractor will advise employees and applicants for employment of available training programs and entrance requirements for each.

d. The contractor will periodically review the training and promotion potential of employees who are minorities and women and will encourage eligible employees to apply for such training and promotion.

7. Unions: If the contractor relies in whole or in part upon unions as a source of employees, the contractor will use good faith efforts to obtain the cooperation of such unions to increase opportunities for minorities and women. Actions by the contractor, either directly or through a contractor's association acting as agent, will include the procedures set forth below:

a. The contractor will use good faith efforts to develop, in cooperation with the unions, joint training programs aimed toward qualifying more minorities and women for membership in the unions and increasing the skills of minorities and women so that they may qualify for higher paying employment.

b. The contractor will use good faith efforts to incorporate an EEO clause into each union agreement to the end that such union will be contractually bound to refer applicants without regard to their race, color, religion, sex, national origin, age or disability.

c. The contractor is to obtain information as to the referral practices and policies of the labor union except that to the extent such information is within the exclusive possession of the labor union and such labor union refuses to furnish such information to the contractor, the contractor shall so certify to the contracting agency and shall set forth what efforts have been made to obtain such information.

d. In the event the union is unable to provide the contractor with a reasonable flow of referrals within the time limit set forth in the collective bargaining agreement, the contractor will, through independent recruitment efforts, fill the employment vacancies without regard to race, color, religion, sex, national origin, age or disability; making full efforts to obtain qualified and/or qualifiable minorities and women. The failure of a union to provide sufficient referrals (even though it is obligated to provide exclusive referrals under the terms of a collective bargaining agreement) does not relieve the contractor from the requirements of this paragraph. In the event the union referral practice prevents the contractor from meeting the obligations pursuant to Executive Order 11246, as amended, and these special provisions, such contractor shall immediately notify the contracting agency.

8. Reasonable Accommodation for Applicants / Employees with Disabilities: The contractor must be familiar with the requirements for and comply with the Americans with Disabilities Act and all rules and regulations established there under. Employers must provide reasonable accommodation in all employment activities unless to do so would cause an undue hardship.

9. Selection of Subcontractors, Procurement of Materials and Leasing of Equipment: The contractor shall not discriminate on the grounds of race, color, religion, sex, national origin, age or disability in the selection and retention of subcontractors, including procurement of materials and leases of equipment. The contractor shall take all necessary and reasonable steps to ensure nondiscrimination in the administration of this contract.

a. The contractor shall notify all potential subcontractors and suppliers and lessors of their EEO obligations under this contract.

b. The contractor will use good faith efforts to ensure subcontractor compliance with their EEO obligations.

10. Assurance Required by 49 CFR 26.13(b):

a. The requirements of 49 CFR Part 26 and the State DOT's U.S. DOT-approved DBE program are incorporated by reference.

b. The contractor or subcontractor shall not discriminate on the basis of race, color, national origin, or sex in the performance of this contract. The contractor shall carry out applicable requirements of 49 CFR Part 26 in the award and administration of DOT-assisted contracts. Failure by the contractor to carry out these requirements is a material breach of this contract, which may result in the termination of this contract or such other remedy as the contracting agency deems appropriate.

11. Records and Reports: The contractor shall keep such records as necessary to document compliance with the EEO requirements. Such records shall be retained for a period of three years following the date of the final payment to the contractor for all contract work and shall be available at reasonable times and places for inspection by authorized representatives of the contracting agency and the FHWA.

a. The records kept by the contractor shall document the following:

(1) The number and work hours of minority and non-minority group members and women employed in each work classification on the project;

(2) The progress and efforts being made in cooperation with unions, when applicable, to increase employment opportunities for minorities and women; and

(3) The progress and efforts being made in locating, hiring, training, qualifying, and upgrading minorities and women;

b. The contractors and subcontractors will submit an annual report to the contracting agency each July for the duration of the project, indicating the number of minority, women, and non-minority group employees currently engaged in each work classification required by the contract work. This information is to be reported on [Form FHWA-1391](#). The staffing data should represent the project work force on board in all or any part of the last payroll period preceding the end of July. If on-the-job training is being required by special provision, the contractor will be required to collect and report training data. The employment data should reflect the work force on board during all or any part of the last payroll period preceding the end of July.

III. NONSEGREGATED FACILITIES

This provision is applicable to all Federal-aid construction contracts and to all related construction subcontracts of \$10,000 or more.

The contractor must ensure that facilities provided for employees are provided in such a manner that segregation on the basis of race, color, religion, sex, or national origin cannot result. The contractor may

EXHIBIT 6 - FEDERAL AID PROVISIONS

neither require such segregated use by written or oral policies nor tolerate such use by employee custom. The contractor's obligation extends further to ensure that its employees are not assigned to perform their services at any location, under the contractor's control, where the facilities are segregated. The term "facilities" includes waiting rooms, work areas, restaurants and other eating areas, time clocks, restrooms, washrooms, locker rooms, and other storage or dressing areas, parking lots, drinking fountains, recreation or entertainment areas, transportation, and housing provided for employees. The contractor shall provide separate or single-user restrooms and necessary dressing or sleeping areas to assure privacy between sexes.

IV. Davis-Bacon and Related Act Provisions

This section is applicable to all Federal-aid construction projects exceeding \$2,000 and to all related subcontracts and lower-tier subcontracts (regardless of subcontract size). The requirements apply to all projects located within the right-of-way of a roadway that is functionally classified as Federal-aid highway. This excludes roadways functionally classified as local roads or rural minor collectors, which are exempt. Contracting agencies may elect to apply these requirements to other projects.

The following provisions are from the U.S. Department of Labor regulations in 29 CFR 5.5 "Contract provisions and related matters" with minor revisions to conform to the FHWA-1273 format and FHWA program requirements.

1. Minimum wages

a. All laborers and mechanics employed or working upon the site of the work, will be paid unconditionally and not less often than once a week, and without subsequent deduction or rebate on any account (except such payroll deductions as are permitted by regulations issued by the Secretary of Labor under the Copeland Act (29 CFR part 3)), the full amount of wages and bona fide fringe benefits (or cash equivalents thereof) due at time of payment computed at rates not less than those contained in the wage determination of the Secretary of Labor which is attached hereto and made a part hereof, regardless of any contractual relationship which may be alleged to exist between the contractor and such laborers and mechanics.

Contributions made or costs reasonably anticipated for bona fide fringe benefits under section 1(b)(2) of the Davis-Bacon Act on behalf of laborers or mechanics are considered wages paid to such laborers or mechanics, subject to the provisions of paragraph 1.d. of this section; also, regular contributions made or costs incurred for more than a weekly period (but not less often than quarterly) under plans, funds, or programs which cover the particular weekly period, are deemed to be constructively made or incurred during such weekly period. Such laborers and mechanics shall be paid the appropriate wage rate and fringe benefits on the wage determination for the classification of work actually performed, without regard to skill, except as provided in 29 CFR 5.5(a)(4). Laborers or mechanics performing work in more than one classification may be compensated at the rate specified for each classification for the time actually worked therein: Provided, That the employer's payroll records accurately set forth the time spent in each classification in which work is performed. The wage determination (including any additional classification and wage rates conformed under paragraph 1.b. of this section) and the Davis-Bacon poster (WH-1321) shall be posted at all times by the contractor and its subcontractors at the site of the work in a prominent and accessible place where it can be easily seen by the workers.

b. (1) The contracting officer shall require that any class of laborers or mechanics, including helpers, which is not listed in the wage determination and which is to be employed under the contract shall be classified in conformance with the wage determination. The contracting officer shall approve an additional classification and

wage rate and fringe benefits therefore only when the following criteria have been met:

(i) The work to be performed by the classification requested is not performed by a classification in the wage determination; and

(ii) The classification is utilized in the area by the construction industry; and

(iii) The proposed wage rate, including any bona fide fringe benefits, bears a reasonable relationship to the wage rates contained in the wage determination.

(2) If the contractor and the laborers and mechanics to be employed in the classification (if known), or their representatives, and the contracting officer agree on the classification and wage rate (including the amount designated for fringe benefits where appropriate), a report of the action taken shall be sent by the contracting officer to the Administrator of the Wage and Hour Division, Employment Standards Administration, U.S. Department of Labor, Washington, DC 20210. The Administrator, or an authorized representative, will approve, modify, or disapprove every additional classification action within 30 days of receipt and so advise the contracting officer or will notify the contracting officer within the 30-day period that additional time is necessary.

(3) In the event the contractor, the laborers or mechanics to be employed in the classification or their representatives, and the contracting officer do not agree on the proposed classification and wage rate (including the amount designated for fringe benefits, where appropriate), the contracting officer shall refer the questions, including the views of all interested parties and the recommendation of the contracting officer, to the Wage and Hour Administrator for determination. The Wage and Hour Administrator, or an authorized representative, will issue a determination within 30 days of receipt and so advise the contracting officer or will notify the contracting officer within the 30-day period that additional time is necessary.

(4) The wage rate (including fringe benefits where appropriate) determined pursuant to paragraphs 1.b.(2) or 1.b.(3) of this section, shall be paid to all workers performing work in the classification under this contract from the first day on which work is performed in the classification.

c. Whenever the minimum wage rate prescribed in the contract for a class of laborers or mechanics includes a fringe benefit which is not expressed as an hourly rate, the contractor shall either pay the benefit as stated in the wage determination or shall pay another bona fide fringe benefit or an hourly cash equivalent thereof.

d. If the contractor does not make payments to a trustee or other third person, the contractor may consider as part of the wages of any laborer or mechanic the amount of any costs reasonably anticipated in providing bona fide fringe benefits under a plan or program, Provided, That the Secretary of Labor has found, upon the written request of the contractor, that the applicable standards of the Davis-Bacon Act have been met.

EXHIBIT 6 - FEDERAL AID PROVISIONS

The Secretary of Labor may require the contractor to set aside in a separate account assets for the meeting of obligations under the plan or program.

2. Withholding

The contracting agency shall upon its own action or upon written request of an authorized representative of the Department of Labor, withhold or cause to be withheld from the contractor under this contract, or any other Federal contract with the same prime contractor, or any other federally-assisted contract subject to Davis-Bacon prevailing wage requirements, which is held by the same prime contractor, so much of the accrued payments or advances as may be considered necessary to pay laborers and mechanics, including apprentices, trainees, and helpers, employed by the contractor or any subcontractor the full amount of wages required by the contract. In the event of failure to pay any laborer or mechanic, including any apprentice, trainee, or helper, employed or working on the site of the work, all or part of the wages required by the contract, the contracting agency may, after written notice to the contractor, take such action as may be necessary to cause the suspension of any further payment, advance, or guarantee of funds until such violations have ceased.

3. Payrolls and basic records

a. Payrolls and basic records relating thereto shall be maintained by the contractor during the course of the work and preserved for a period of three years thereafter for all laborers and mechanics working at the site of the work. Such records shall contain the name, address, and social security number of each such worker, his or her correct classification, hourly rates of wages paid (including rates of contributions or costs anticipated for bona fide fringe benefits or cash equivalents thereof of the types described in section 1(b)(2)(B) of the Davis-Bacon Act), daily and weekly number of hours worked, deductions made and actual wages paid. Whenever the Secretary of Labor has found under 29 CFR 5.5(a)(1)(iv) that the wages of any laborer or mechanic include the amount of any costs reasonably anticipated in providing benefits under a plan or program described in section 1(b)(2)(B) of the Davis-Bacon Act, the contractor shall maintain records which show that the commitment to provide such benefits is enforceable, that the plan or program is financially responsible, and that the plan or program has been communicated in writing to the laborers or mechanics affected, and records which show the costs anticipated or the actual cost incurred in providing such benefits. Contractors employing apprentices or trainees under approved programs shall maintain written evidence of the registration of apprenticeship programs and certification of trainee programs, the registration of the apprentices and trainees, and the ratios and wage rates prescribed in the applicable programs.

b. (1) The contractor shall submit weekly for each week in which any contract work is performed a copy of all payrolls to the contracting agency. The payrolls submitted shall set out accurately and completely all of the information required to be maintained under 29 CFR 5.5(a)(3)(i), except that full social security numbers and home addresses shall not be included on weekly transmittals. Instead the payrolls shall only need to include an individually identifying number for each employee (e.g., the last four digits of the employee's social security number). The required weekly payroll information may be submitted in any form desired. Optional Form WH-347 is available for this purpose from the Wage and Hour Division Web site at <http://www.dol.gov/esa/whd/forms/wh347instr.htm> or its successor site. The prime contractor is responsible for the submission of copies of payrolls by all subcontractors. Contractors and subcontractors shall maintain the full social security number and current address of each covered worker, and shall provide them upon request to the contracting agency for transmission to the State DOT, the FHWA or the Wage and Hour Division of the Department of Labor for purposes of an investigation or audit of compliance with prevailing wage requirements. It is not a violation of this section for a prime contractor to require a subcontractor to provide addresses

and social security numbers to the prime contractor for its own records, without weekly submission to the contracting agency..

(2) Each payroll submitted shall be accompanied by a "Statement of Compliance," signed by the contractor or subcontractor or his or her agent who pays or supervises the payment of the persons employed under the contract and shall certify the following:

(i) That the payroll for the payroll period contains the information required to be provided under §5.5 (a)(3)(ii) of Regulations, 29 CFR part 5, the appropriate information is being maintained under §5.5 (a)(3)(i) of Regulations, 29 CFR part 5, and that such information is correct and complete;

(ii) That each laborer or mechanic (including each helper, apprentice, and trainee) employed on the contract during the payroll period has been paid the full weekly wages earned, without rebate, either directly or indirectly, and that no deductions have been made either directly or indirectly from the full wages earned, other than permissible deductions as set forth in Regulations, 29 CFR part 3;

(iii) That each laborer or mechanic has been paid not less than the applicable wage rates and fringe benefits or cash equivalents for the classification of work performed, as specified in the applicable wage determination incorporated into the contract.

(3) The weekly submission of a properly executed certification set forth on the reverse side of Optional Form WH-347 shall satisfy the requirement for submission of the "Statement of Compliance" required by paragraph 3.b.(2) of this section.

(4) The falsification of any of the above certifications may subject the contractor or subcontractor to civil or criminal prosecution under section 1001 of title 18 and section 231 of title 31 of the United States Code.

c. The contractor or subcontractor shall make the records required under paragraph 3.a. of this section available for inspection, copying, or transcription by authorized representatives of the contracting agency, the State DOT, the FHWA, or the Department of Labor, and shall permit such representatives to interview employees during working hours on the job. If the contractor or subcontractor fails to submit the required records or to make them available, the FHWA may, after written notice to the contractor, the contracting agency or the State DOT, take such action as may be necessary to cause the suspension of any further payment, advance, or guarantee of funds. Furthermore, failure to submit the required records upon request or to make such records available may be grounds for debarment action pursuant to 29 CFR 5.12.

4. Apprentices and trainees

a. Apprentices (programs of the USDOL).

EXHIBIT 6 - FEDERAL AID PROVISIONS

Apprentices will be permitted to work at less than the predetermined rate for the work they performed when they are employed pursuant to and individually registered in a bona fide apprenticeship program registered with the U.S. Department of Labor, Employment and Training Administration, Office of Apprenticeship Training, Employer and Labor Services, or with a State Apprenticeship Agency recognized by the Office, or if a person is employed in his or her first 90 days of probationary employment as an apprentice in such an apprenticeship program, who is not individually registered in the program, but who has been certified by the Office of Apprenticeship Training, Employer and Labor Services or a State Apprenticeship Agency (where appropriate) to be eligible for probationary employment as an apprentice.

The allowable ratio of apprentices to journeymen on the job site in any craft classification shall not be greater than the ratio permitted to the contractor as to the entire work force under the registered program. Any worker listed on a payroll at an apprentice wage rate, who is not registered or otherwise employed as stated above, shall be paid not less than the applicable wage rate on the wage determination for the classification of work actually performed. In addition, any apprentice performing work on the job site in excess of the ratio permitted under the registered program shall be paid not less than the applicable wage rate on the wage determination for the work actually performed. Where a contractor is performing construction on a project in a locality other than that in which its program is registered, the ratios and wage rates (expressed in percentages of the journeyman's hourly rate) specified in the contractor's or subcontractor's registered program shall be observed.

Every apprentice must be paid at not less than the rate specified in the registered program for the apprentice's level of progress, expressed as a percentage of the journeymen hourly rate specified in the applicable wage determination. Apprentices shall be paid fringe benefits in accordance with the provisions of the apprenticeship program. If the apprenticeship program does not specify fringe benefits, apprentices must be paid the full amount of fringe benefits listed on the wage determination for the applicable classification. If the Administrator determines that a different practice prevails for the applicable apprentice classification, fringes shall be paid in accordance with that determination.

In the event the Office of Apprenticeship Training, Employer and Labor Services, or a State Apprenticeship Agency recognized by the Office, withdraws approval of an apprenticeship program, the contractor will no longer be permitted to utilize apprentices at less than the applicable predetermined rate for the work performed until an acceptable program is approved.

b. Trainees (programs of the USDOL).

Except as provided in 29 CFR 5.16, trainees will not be permitted to work at less than the predetermined rate for the work performed unless they are employed pursuant to and individually registered in a program which has received prior approval, evidenced by formal certification by the U.S. Department of Labor, Employment and Training Administration.

The ratio of trainees to journeymen on the job site shall not be greater than permitted under the plan approved by the Employment and Training Administration.

Every trainee must be paid at not less than the rate specified in the approved program for the trainee's level of progress, expressed as a percentage of the journeyman hourly rate specified in the applicable wage determination. Trainees shall be paid fringe benefits in accordance with the provisions of the trainee program. If the trainee program does not mention fringe benefits, trainees shall be paid the full amount of fringe benefits listed on the wage determination unless the Administrator of the Wage and Hour Division determines that there is an apprenticeship program associated with the

corresponding journeyman wage rate on the wage determination which provides for less than full fringe benefits for apprentices. Any employee listed on the payroll at a trainee rate who is not registered and participating in a training plan approved by the Employment and Training Administration shall be paid not less than the applicable wage rate on the wage determination for the classification of work actually performed. In addition, any trainee performing work on the job site in excess of the ratio permitted under the registered program shall be paid not less than the applicable wage rate on the wage determination for the work actually performed.

In the event the Employment and Training Administration withdraws approval of a training program, the contractor will no longer be permitted to utilize trainees at less than the applicable predetermined rate for the work performed until an acceptable program is approved.

c. Equal employment opportunity. The utilization of apprentices, trainees and journeymen under this part shall be in conformity with the equal employment opportunity requirements of Executive Order 11246, as amended, and 29 CFR part 30.

d. Apprentices and Trainees (programs of the U.S. DOT).

Apprentices and trainees working under apprenticeship and skill training programs which have been certified by the Secretary of Transportation as promoting EEO in connection with Federal-aid highway construction programs are not subject to the requirements of paragraph 4 of this Section IV. The straight time hourly wage rates for apprentices and trainees under such programs will be established by the particular programs. The ratio of apprentices and trainees to journeymen shall not be greater than permitted by the terms of the particular program.

5. Compliance with Copeland Act requirements.

The contractor shall comply with the requirements of 29 CFR part 3, which are incorporated by reference in this contract.

6. Subcontracts. The contractor or subcontractor shall insert Form FHWA-1273 in any subcontracts and also require the subcontractors to include Form FHWA-1273 in any lower tier subcontracts. The prime contractor shall be responsible for the compliance by any subcontractor or lower tier subcontractor with all the contract clauses in 29 CFR 5.5.

7. Contract termination: debarment. A breach of the contract clauses in 29 CFR 5.5 may be grounds for termination of the contract, and for debarment as a contractor and a subcontractor as provided in 29 CFR 5.12.

8. Compliance with Davis-Bacon and Related Act requirements. All rulings and interpretations of the Davis-Bacon and Related Acts contained in 29 CFR parts 1, 3, and 5 are herein incorporated by reference in this contract.

9. Disputes concerning labor standards. Disputes arising out of the labor standards provisions of this contract shall not be subject to the general disputes

EXHIBIT 6 - FEDERAL AID PROVISIONS

clause of this contract. Such disputes shall be resolved in accordance with the procedures of the Department of Labor set forth in 29 CFR parts 5, 6, and 7. Disputes within the meaning of this clause include disputes between the contractor (or any of its subcontractors) and the contracting agency, the U.S. Department of Labor, or the employees or their representatives.

10. Certification of eligibility.

a. By entering into this contract, the contractor certifies that neither it (nor he or she) nor any person or firm who has an interest in the contractor's firm is a person or firm ineligible to be awarded Government contracts by virtue of section 3(a) of the Davis-Bacon Act or 29 CFR 5.12(a)(1).

b. No part of this contract shall be subcontracted to any person or firm ineligible for award of a Government contract by virtue of section 3(a) of the Davis-Bacon Act or 29 CFR 5.12(a)(1).

c. The penalty for making false statements is prescribed in the U.S. Criminal Code, 18 U.S.C. 1001.

V. CONTRACT WORK HOURS AND SAFETY STANDARDS ACT

The following clauses apply to any Federal-aid construction contract in an amount in excess of \$100,000 and subject to the overtime provisions of the Contract Work Hours and Safety Standards Act. These clauses shall be inserted in addition to the clauses required by 29 CFR 5.5(a) or 29 CFR 4.6. As used in this paragraph, the terms laborers and mechanics include watchmen and guards.

1. Overtime requirements. No contractor or subcontractor contracting for any part of the contract work which may require or involve the employment of laborers or mechanics shall require or permit any such laborer or mechanic in any workweek in which he or she is employed on such work to work in excess of forty hours in such workweek unless such laborer or mechanic receives compensation at a rate not less than one and one-half times the basic rate of pay for all hours worked in excess of forty hours in such workweek.

2. Violation; liability for unpaid wages; liquidated damages. In the event of any violation of the clause set forth in paragraph (1.) of this section, the contractor and any subcontractor responsible therefor shall be liable for the unpaid wages. In addition, such contractor and subcontractor shall be liable to the United States (in the case of work done under contract for the District of Columbia or a territory, to such District or to such territory), for liquidated damages. Such liquidated damages shall be computed with respect to each individual laborer or mechanic, including watchmen and guards, employed in violation of the clause set forth in paragraph (1.) of this section, in the sum of \$10 for each calendar day on which such individual was required or permitted to work in excess of the standard workweek of forty hours without payment of the overtime wages required by the clause set forth in paragraph (1.) of this section.

3. Withholding for unpaid wages and liquidated damages. The FHWA or the contracting agency shall upon its own action or upon written request of an authorized representative of the Department of Labor withhold or cause to be withheld, from any moneys payable on account of work performed by the contractor or subcontractor under any such contract or any other Federal contract with the same prime contractor, or any other federally-assisted contract subject to the Contract Work Hours and Safety Standards Act, which is held by the same prime contractor, such sums as may be determined to be necessary to satisfy any liabilities of such contractor or subcontractor for unpaid wages and liquidated damages as provided in the clause set forth in paragraph (2.) of this section.

4. Subcontracts. The contractor or subcontractor shall insert in any subcontracts the clauses set forth in paragraph (1.) through (4.) of this section and also a clause requiring the subcontractors to include these clauses in any lower tier subcontracts. The prime contractor shall be responsible for compliance by any subcontractor or lower tier subcontractor with the clauses set forth in paragraphs (1.) through (4.) of this section.

VI. SUBLETTING OR ASSIGNING THE CONTRACT

This provision is applicable to all Federal-aid construction contracts on the National Highway System.

1. The contractor shall perform with its own organization contract work amounting to not less than 30 percent (or a greater percentage if specified elsewhere in the contract) of the total original contract price, excluding any specialty items designated by the contracting agency. Specialty items may be performed by subcontract and the amount of any such specialty items performed may be deducted from the total original contract price before computing the amount of work required to be performed by the contractor's own organization (23 CFR 635.116).

a. The term "perform work with its own organization" refers to workers employed or leased by the prime contractor, and equipment owned or rented by the prime contractor, with or without operators. Such term does not include employees or equipment of a subcontractor or lower tier subcontractor, agents of the prime contractor, or any other assignees. The term may include payments for the costs of hiring leased employees from an employee leasing firm meeting all relevant Federal and State regulatory requirements. Leased employees may only be included in this term if the prime contractor meets all of the following conditions:

(1) the prime contractor maintains control over the supervision of the day-to-day activities of the leased employees;

(2) the prime contractor remains responsible for the quality of the work of the leased employees;

(3) the prime contractor retains all power to accept or exclude individual employees from work on the project; and

(4) the prime contractor remains ultimately responsible for the payment of predetermined minimum wages, the submission of payrolls, statements of compliance and all other Federal regulatory requirements.

b. "Specialty Items" shall be construed to be limited to work that requires highly specialized knowledge, abilities, or equipment not ordinarily available in the type of contracting organizations qualified and expected to bid or propose on the contract as a whole and in general are to be limited to minor components of the overall contract.

2. The contract amount upon which the requirements set forth in paragraph (1) of Section VI is computed includes the cost of material and manufactured products which are to be purchased or produced by the contractor under the contract provisions.

EXHIBIT 6 - FEDERAL AID PROVISIONS

3. The contractor shall furnish (a) a competent superintendent or supervisor who is employed by the firm, has full authority to direct performance of the work in accordance with the contract requirements, and is in charge of all construction operations (regardless of who performs the work) and (b) such other of its own organizational resources (supervision, management, and engineering services) as the contracting officer determines is necessary to assure the performance of the contract.

4. No portion of the contract shall be sublet, assigned or otherwise disposed of except with the written consent of the contracting officer, or authorized representative, and such consent when given shall not be construed to relieve the contractor of any responsibility for the fulfillment of the contract. Written consent will be given only after the contracting agency has assured that each subcontract is evidenced in writing and that it contains all pertinent provisions and requirements of the prime contract.

5. The 30% self-performance requirement of paragraph (1) is not applicable to design-build contracts; however, contracting agencies may establish their own self-performance requirements.

VII. SAFETY: ACCIDENT PREVENTION

This provision is applicable to all Federal-aid construction contracts and to all related subcontracts.

1. In the performance of this contract the contractor shall comply with all applicable Federal, State, and local laws governing safety, health, and sanitation (23 CFR 635). The contractor shall provide all safeguards, safety devices and protective equipment and take any other needed actions as it determines, or as the contracting officer may determine, to be reasonably necessary to protect the life and health of employees on the job and the safety of the public and to protect property in connection with the performance of the work covered by the contract.

2. It is a condition of this contract, and shall be made a condition of each subcontract, which the contractor enters into pursuant to this contract, that the contractor and any subcontractor shall not permit any employee, in performance of the contract, to work in surroundings or under conditions which are unsanitary, hazardous or dangerous to his/her health or safety, as determined under construction safety and health standards (29 CFR 1926) promulgated by the Secretary of Labor, in accordance with Section 107 of the Contract Work Hours and Safety Standards Act (40 U.S.C. 3704).

3. Pursuant to 29 CFR 1926.3, it is a condition of this contract that the Secretary of Labor or authorized representative thereof, shall have right of entry to any site of contract performance to inspect or investigate the matter of compliance with the construction safety and health standards and to carry out the duties of the Secretary under Section 107 of the Contract Work Hours and Safety Standards Act (40 U.S.C.3704).

VIII. FALSE STATEMENTS CONCERNING HIGHWAY PROJECTS

This provision is applicable to all Federal-aid construction contracts and to all related subcontracts.

In order to assure high quality and durable construction in conformity with approved plans and specifications and a high degree of reliability on statements and representations made by engineers, contractors, suppliers, and workers on Federal-aid highway projects, it is essential that all persons concerned with the project perform their functions as carefully, thoroughly, and honestly as possible. Willful falsification, distortion, or misrepresentation with respect to any facts related to the project is a violation of Federal law. To prevent any misunderstanding regarding the seriousness of these and similar acts, Form FHWA-1022 shall be posted on each

Federal-aid highway project (23 CFR 635) in one or more places where it is readily available to all persons concerned with the project:

18 U.S.C. 1020 reads as follows:

"Whoever, being an officer, agent, or employee of the United States, or of any State or Territory, or whoever, whether a person, association, firm, or corporation, knowingly makes any false statement, false representation, or false report as to the character, quality, quantity, or cost of the material used or to be used, or the quantity or quality of the work performed or to be performed, or the cost thereof in connection with the submission of plans, maps, specifications, contracts, or costs of construction on any highway or related project submitted for approval to the Secretary of Transportation; or

Whoever knowingly makes any false statement, false representation, false report or false claim with respect to the character, quality, quantity, or cost of any work performed or to be performed, or materials furnished or to be furnished, in connection with the construction of any highway or related project approved by the Secretary of Transportation; or

Whoever knowingly makes any false statement or false representation as to material fact in any statement, certificate, or report submitted pursuant to provisions of the Federal-aid Roads Act approved July 1, 1916, (39 Stat. 355), as amended and supplemented;

Shall be fined under this title or imprisoned not more than 5 years or both."

IX. IMPLEMENTATION OF CLEAN AIR ACT AND FEDERAL WATER POLLUTION CONTROL ACT

This provision is applicable to all Federal-aid construction contracts and to all related subcontracts.

By submission of this bid/proposal or the execution of this contract, or subcontract, as appropriate, the bidder, proposer, Federal-aid construction contractor, or subcontractor, as appropriate, will be deemed to have stipulated as follows:

1. That any person who is or will be utilized in the performance of this contract is not prohibited from receiving an award due to a violation of Section 508 of the Clean Water Act or Section 306 of the Clean Air Act.

2. That the contractor agrees to include or cause to be included the requirements of paragraph (1) of this Section X in every subcontract, and further agrees to take such action as the contracting agency may direct as a means of enforcing such requirements.

X. CERTIFICATION REGARDING DEBARMENT, SUSPENSION, INELIGIBILITY AND VOLUNTARY EXCLUSION

This provision is applicable to all Federal-aid construction contracts, design-build contracts, subcontracts, lower-tier subcontracts, purchase orders, lease agreements, consultant contracts or any other covered transaction requiring FHWA

EXHIBIT 6 - FEDERAL AID PROVISIONS

approval or that is estimated to cost \$25,000 or more – as defined in 2 CFR Parts 180 and 1200.

1. Instructions for Certification – First Tier Participants:

a. By signing and submitting this proposal, the prospective first tier participant is providing the certification set out below.

b. The inability of a person to provide the certification set out below will not necessarily result in denial of participation in this covered transaction. The prospective first tier participant shall submit an explanation of why it cannot provide the certification set out below. The certification or explanation will be considered in connection with the department or agency's determination whether to enter into this transaction. However, failure of the prospective first tier participant to furnish a certification or an explanation shall disqualify such a person from participation in this transaction.

c. The certification in this clause is a material representation of fact upon which reliance was placed when the contracting agency determined to enter into this transaction. If it is later determined that the prospective participant knowingly rendered an erroneous certification, in addition to other remedies available to the Federal Government, the contracting agency may terminate this transaction for cause of default.

d. The prospective first tier participant shall provide immediate written notice to the contracting agency to whom this proposal is submitted if any time the prospective first tier participant learns that its certification was erroneous when submitted or has become erroneous by reason of changed circumstances.

e. The terms "covered transaction," "debarred," "suspended," "ineligible," "participant," "person," "principal," and "voluntarily excluded," as used in this clause, are defined in 2 CFR Parts 180 and 1200. "First Tier Covered Transactions" refers to any covered transaction between a grantee or subgrantee of Federal funds and a participant (such as the prime or general contract). "Lower Tier Covered Transactions" refers to any covered transaction under a First Tier Covered Transaction (such as subcontracts). "First Tier Participant" refers to the participant who has entered into a covered transaction with a grantee or subgrantee of Federal funds (such as the prime or general contractor). "Lower Tier Participant" refers any participant who has entered into a covered transaction with a First Tier Participant or other Lower Tier Participants (such as subcontractors and suppliers).

f. The prospective first tier participant agrees by submitting this proposal that, should the proposed covered transaction be entered into, it shall not knowingly enter into any lower tier covered transaction with a person who is debarred, suspended, declared ineligible, or voluntarily excluded from participation in this covered transaction, unless authorized by the department or agency entering into this transaction.

g. The prospective first tier participant further agrees by submitting this proposal that it will include the clause titled "Certification Regarding Debarment, Suspension, Ineligibility and Voluntary Exclusion-Lower Tier Covered Transactions," provided by the department or contracting agency, entering into this covered transaction, without modification, in all lower tier covered transactions and in all solicitations for lower tier covered transactions exceeding the \$25,000 threshold.

h. A participant in a covered transaction may rely upon a certification of a prospective participant in a lower tier covered transaction that is not debarred, suspended, ineligible, or voluntarily excluded from the covered transaction, unless it knows that the certification is erroneous. A participant is responsible for ensuring that its principals are not suspended, debarred, or otherwise ineligible to participate in covered transactions. To verify the eligibility of its principals, as well as the eligibility of any lower tier prospective participants, each participant may, but is not required to,

check the Excluded Parties List System website (<https://www.epls.gov/>), which is compiled by the General Services Administration.

i. Nothing contained in the foregoing shall be construed to require the establishment of a system of records in order to render in good faith the certification required by this clause. The knowledge and information of the prospective participant is not required to exceed that which is normally possessed by a prudent person in the ordinary course of business dealings.

j. Except for transactions authorized under paragraph (f) of these instructions, if a participant in a covered transaction knowingly enters into a lower tier covered transaction with a person who is suspended, debarred, ineligible, or voluntarily excluded from participation in this transaction, in addition to other remedies available to the Federal Government, the department or agency may terminate this transaction for cause or default.

2. Certification Regarding Debarment, Suspension, Ineligibility and Voluntary Exclusion – First Tier Participants:

a. The prospective first tier participant certifies to the best of its knowledge and belief, that it and its principals:

(1) Are not presently debarred, suspended, proposed for debarment, declared ineligible, or voluntarily excluded from participating in covered transactions by any Federal department or agency;

(2) Have not within a three-year period preceding this proposal been convicted of or had a civil judgment rendered against them for commission of fraud or a criminal offense in connection with obtaining, attempting to obtain, or performing a public (Federal, State or local) transaction or contract under a public transaction; violation of Federal or State antitrust statutes or commission of embezzlement, theft, forgery, bribery, falsification or destruction of records, making false statements, or receiving stolen property;

(3) Are not presently indicted for or otherwise criminally or civilly charged by a governmental entity (Federal, State or local) with commission of any of the offenses enumerated in paragraph (a)(2) of this certification; and

(4) Have not within a three-year period preceding this application/proposal had one or more public transactions (Federal, State or local) terminated for cause or default.

b. Where the prospective participant is unable to certify to any of the statements in this certification, such prospective participant shall attach an explanation to this proposal.

2. Instructions for Certification - Lower Tier Participants:

(Applicable to all subcontracts, purchase orders and other lower tier transactions requiring prior FHWA approval or estimated to cost \$25,000 or more - 2 CFR Parts 180 and 1200)

EXHIBIT 6 - FEDERAL AID PROVISIONS

a. By signing and submitting this proposal, the prospective lower tier is providing the certification set out below.

b. The certification in this clause is a material representation of fact upon which reliance was placed when this transaction was entered into. If it is later determined that the prospective lower tier participant knowingly rendered an erroneous certification, in addition to other remedies available to the Federal Government, the department, or agency with which this transaction originated may pursue available remedies, including suspension and/or debarment.

c. The prospective lower tier participant shall provide immediate written notice to the person to which this proposal is submitted if at any time the prospective lower tier participant learns that its certification was erroneous by reason of changed circumstances.

d. The terms "covered transaction," "debarred," "suspended," "ineligible," "participant," "person," "principal," and "voluntarily excluded," as used in this clause, are defined in 2 CFR Parts 180 and 1200. You may contact the person to which this proposal is submitted for assistance in obtaining a copy of those regulations. "First Tier Covered Transactions" refers to any covered transaction between a grantee or subgrantee of Federal funds and a participant (such as the prime or general contract). "Lower Tier Covered Transactions" refers to any covered transaction under a First Tier Covered Transaction (such as subcontracts). "First Tier Participant" refers to the participant who has entered into a covered transaction with a grantee or subgrantee of Federal funds (such as the prime or general contractor). "Lower Tier Participant" refers any participant who has entered into a covered transaction with a First Tier Participant or other Lower Tier Participants (such as subcontractors and suppliers).

e. The prospective lower tier participant agrees by submitting this proposal that, should the proposed covered transaction be entered into, it shall not knowingly enter into any lower tier covered transaction with a person who is debarred, suspended, declared ineligible, or voluntarily excluded from participation in this covered transaction, unless authorized by the department or agency with which this transaction originated.

f. The prospective lower tier participant further agrees by submitting this proposal that it will include this clause titled "Certification Regarding Debarment, Suspension, Ineligibility and Voluntary Exclusion-Lower Tier Covered Transaction," without modification, in all lower tier covered transactions and in all solicitations for lower tier covered transactions exceeding the \$25,000 threshold.

g. A participant in a covered transaction may rely upon a certification of a prospective participant in a lower tier covered transaction that is not debarred, suspended, ineligible, or voluntarily excluded from the covered transaction, unless it knows that the certification is erroneous. A participant is responsible for ensuring that its principals are not suspended, debarred, or otherwise ineligible to participate in covered transactions. To verify the eligibility of its principals, as well as the eligibility of any lower tier prospective participants, each participant may, but is not required to, check the Excluded Parties List System website (<https://www.epls.gov/>), which is compiled by the General Services Administration.

h. Nothing contained in the foregoing shall be construed to require establishment of a system of records in order to render in good faith the certification required by this clause. The knowledge and information of participant is not required to exceed that which is normally possessed by a prudent person in the ordinary course of business dealings.

i. Except for transactions authorized under paragraph e of these instructions, if a participant in a covered transaction knowingly enters into a lower tier covered transaction with a person who is

suspended, debarred, ineligible, or voluntarily excluded from participation in this transaction, in addition to other remedies available to the Federal Government, the department or agency with which this transaction originated may pursue available remedies, including suspension and/or debarment.

Certification Regarding Debarment, Suspension, Ineligibility and Voluntary Exclusion--Lower Tier Participants:

1. The prospective lower tier participant certifies, by submission of this proposal, that neither it nor its principals is presently debarred, suspended, proposed for debarment, declared ineligible, or voluntarily excluded from participating in covered transactions by any Federal department or agency.

2. Where the prospective lower tier participant is unable to certify to any of the statements in this certification, such prospective participant shall attach an explanation to this proposal.

XI. CERTIFICATION REGARDING USE OF CONTRACT FUNDS FOR LOBBYING

This provision is applicable to all Federal-aid construction contracts and to all related subcontracts which exceed \$100,000 (49 CFR 20).

1. The prospective participant certifies, by signing and submitting this bid or proposal, to the best of his or her knowledge and belief, that:

a. No Federal appropriated funds have been paid or will be paid, by or on behalf of the undersigned, to any person for influencing or attempting to influence an officer or employee of any Federal agency, a Member of Congress, an officer or employee of Congress, or an employee of a Member of Congress in connection with the awarding of any Federal contract, the making of any Federal grant, the making of any Federal loan, the entering into of any cooperative agreement, and the extension, continuation, renewal, amendment, or modification of any Federal contract, grant, loan, or cooperative agreement.

b. If any funds other than Federal appropriated funds have been paid or will be paid to any person for influencing or attempting to influence an officer or employee of any Federal agency, a Member of Congress, an officer or employee of Congress, or an employee of a Member of Congress in connection with this Federal contract, grant, loan, or cooperative agreement, the undersigned shall complete and submit Standard Form-LLL, "Disclosure Form to Report Lobbying," in accordance with its instructions.

2. This certification is a material representation of fact upon which reliance was placed when this transaction was made or entered into. Submission of this certification is a prerequisite for making or entering into this transaction imposed by 31 U.S.C. 1352. Any person who fails to file the required certification shall be subject to a civil penalty of not less than \$10,000 and not more than \$100,000 for each such failure.

EXHIBIT 6 - FEDERAL AID PROVISIONS

3. The prospective participant also agrees by submitting its bid or proposal that the participant shall require that the language of this certification be included in all lower tier subcontracts, which exceed \$100,000 and that all such recipients shall certify and disclose accordingly.

EXHIBIT 6 - FEDERAL AID PROVISIONS

ATTACHMENT A - EMPLOYMENT AND MATERIALS PREFERENCE FOR APPALACHIAN DEVELOPMENT HIGHWAY SYSTEM OR APPALACHIAN LOCAL ACCESS ROAD CONTRACTS

This provision is applicable to all Federal-aid projects funded under the Appalachian Regional Development Act of 1965.

1. During the performance of this contract, the contractor undertaking to do work which is, or reasonably may be, done as on-site work, shall give preference to qualified persons who regularly reside in the labor area as designated by the DOL wherein the contract work is situated, or the subregion, or the Appalachian counties of the State wherein the contract work is situated, except:

a. To the extent that qualified persons regularly residing in the area are not available.

b. For the reasonable needs of the contractor to employ supervisory or specially experienced personnel necessary to assure an efficient execution of the contract work.

c. For the obligation of the contractor to offer employment to present or former employees as the result of a lawful collective bargaining contract, provided that the number of nonresident persons employed under this subparagraph (1c) shall not exceed 20 percent of the total number of employees employed by the contractor on the contract work, except as provided in subparagraph (4) below.

2. The contractor shall place a job order with the State Employment Service indicating (a) the classifications of the laborers, mechanics and other employees required to perform the contract work, (b) the number of employees required in each classification, (c) the date on which the participant estimates such employees will be required, and (d) any other pertinent information required by the State Employment Service to complete the job order form. The job order may be placed with the State Employment Service in writing or by telephone. If during the course of the contract work, the information submitted by the contractor in the original job order is substantially modified, the participant shall promptly notify the State Employment Service.

3. The contractor shall give full consideration to all qualified job applicants referred to him by the State Employment Service. The contractor is not required to grant employment to any job applicants who, in his opinion, are not qualified to perform the classification of work required.

4. If, within one week following the placing of a job order by the contractor with the State Employment Service, the State Employment Service is unable to refer any qualified job applicants to the contractor, or less than the number requested, the State Employment Service will forward a certificate to the contractor indicating the unavailability of applicants. Such certificate shall be made a part of the contractor's permanent project records. Upon receipt of this certificate, the contractor may employ persons who do not normally reside in the labor area to fill positions covered by the certificate, notwithstanding the provisions of subparagraph (1c) above.

5. The provisions of 23 CFR 633.207(e) allow the contracting agency to provide a contractual preference for the use of mineral resource materials native to the Appalachian region.

STANDARD FEDERAL EQUAL EMPLOYMENT OPPORTUNITY CONSTRUCTION CONTRACT SPECIFICATIONS

NOTICE OF REQUIREMENT FOR AFFIRMATIVE ACTION TO ENSURE EQUAL EMPLOYMENT OPPORTUNITY (EXECUTIVE ORDER 11246)

1. The Offeror's or Bidders attention is called to the "Equal Opportunity Clause" and the "Standard Federal Equal Employment Opportunity Construction Contract Specifications" set forth herein.
2. The goals and timetables for minority and female participation expressed in percentage terms for the Contractor's aggregate work force in each trade on all construction work in the covered area are as follows:

Goals for Women Apply Nationwide

GOALS AND TIMETABLES

<i>Timetable</i>	<i>Goals (percent)</i>
From Apr. 1, 1976 until March 31, 1979-----	3.1
--	
From Apr. 1, 1979 until March 31, 1980-----	5.1
--	
From Apr. 1, 1980 until March 31, 1981-----	6.9
--	

Goals for Minority Participation

South Carolina	
SMSA Counties:.....	16.0
Greenville, Pickens, Spartanburg	
Non-SMSA Counties:.....	17.8
Abbeville, Anderson, Cherokee, Greenwood, Laurens, Oconee, Union	
SMSA Counties:.....	23.4
Lexington, Richland	
Non-SMSA Counties.....	32.0
Calhoun, Clarendon, Fairfield, Kershaw, Lee, Newberry, Orangeburg, Saluda, Sumter	
Non-SMSA Counties:.....	33.0
Chesterfield, Darlington, Dillon, Florence, Georgetown, Horry, Marion, Marlboro, Williamsburg	
SMSA Counties:.....	30.0
Berkeley, Charleston, Dorchester	
Non-SMSA Counties.....	30.7
Colleton	
Non-SMSA Counties.....	29.8
Beaufort, Hampton, Jasper	
Non-SMSA Counties.....	15.7
Chester Lancaster York	
Non-SMSA Counties.....	32.8
Barnwell, Edgefield, McCormick, Allendale, Bamberg	
SMSA Counties:.....	27.2
Aiken	

These goals are applicable to all the Contractor's construction work (whether or not it is Federal or federally assisted) performed in the covered area. If the Contractor performs construction work in a geographical area located outside of the covered area, it shall apply the goals established for such geographical areas where the work is actually performed. With regard to this second area, the Contractor is also subject to the goals for both its federally involved and nonfederally involved construction.

The Contractor's compliance with the Executive Order and the regulations in 41 CFR Part 60-4 Shall be based on its implementation of the Equal Opportunity Clause, specific

affirmative action obligations required by the specifications set forth in 41 CFR 60-4.3(a) and its efforts to meet the goals established for the geographical area where the contract resulting from this solicitation is to be performed. The hours of minority and female employment and training must be substantially uniform throughout the length of the contract, and in each trade, and the Contractor shall make a good faith effort to employ minorities and women evenly on each of its projects. The transfer of minority or female employees of trainees from Contractor to Contractor or from project to project for the sole purpose of meeting the Contractor's goals shall be a violation of the contract, the Executive Order and the regulations in 41 CFR Part 60-4. Compliance with the goals will be measured against the total work hours performed.

3. The Contractor shall provide written notification to the Director of the Office of Federal Contract Compliance Programs within 10 working days of award of any construction subcontract in excess of \$10,000 at any tier for construction work under the contract resulting from this solicitation. The notification shall list the name, address and telephone number of the subcontractor, employer identification number, estimated dollar amount of the subcontract; estimated starting and completion dates of the subcontract; and the geographical area in which the contract is to be performed.
4. As used in this Notice and in the contract resulting from this solicitation, the "covered area" is (insert description of the geographical areas where the contract is to be performed giving the state, county, and city, if any). The "covered area is the SMSA County or Counties or Non-SMSA County or Counties in which the contract work is performed.

STANDARD FEDERAL EQUAL EMPLOYMENT OPPORTUNITY CONSTRUCTION CONTRACT SPECIFICATIONS (EXECUTIVE ORDER 11246)

1. As used in these specifications:
 - a. "Covered area" means the geographical area described in the solicitation from which this contract resulted;
 - b. "Director" means Director, Office of Federal Contract Compliance Programs, United States Department of Labor, or any person to whom the Director delegates authority;
 - c. "Employer identification number" means the Federal Social Security number used on the Employers Quarterly Federal Tax Return, U. S. Treasury Department Form 941.
 - d. "Minority" includes:
 - (i) Black (all persons having origins in any of the Black African racial groups not of Hispanic origin);
 - (ii) Hispanic (all persons of Mexican, Puerto Rican, Cuban, Central or South American or other Spanish Culture or origin regardless of race);
 - (iii) Asian or Pacific Islander (all persons having origins in any of the original peoples of the Far East, Southeast Asia, the Indian Subcontinent, or the Pacific Islands); and
 - (iv) American Indian or Alaskan Native (all persons having origins in any of the original peoples of North America and maintaining identifiable tribal affiliations through membership and participation or community identification).
2. Whenever the Contractor, or any Subcontractor at any tier, subcontracts a portion of the work involving any construction trade, it shall physically include in each subcontract in excess of \$10,000 the provisions of these specifications and the Notice which contains the applicable goals for minority and

EXHIBIT 6 - FEDERAL AID PROVISIONS

female participation and which is set forth in the solicitations from which this contract resulted.

3. If the Contractor is participating (pursuant to 41 CFR 60-4.5) in a Hometown Plan approved by the U. S. Department of Labor in the covered area either individually or through an association, its affirmative action obligations on all work in the Plan area (including goals and timetables) shall be in accordance with that Plan for those trades which have unions participating in the Plan. Contractors must be able to demonstrate their participation in and compliance with the provisions of any such Hometown Plan. Each Contractor or Subcontractor participating in an approved Plan is individually required to comply with its obligations under the EEO clause, and to make a good faith effort to achieve each goal under the Plan in each trade in which it has employees. The overall good faith performance by other Contractors or Subcontractors toward a goal in an approved Plan does not excuse any covered Contractor's or Subcontractor's failure to take good faith efforts to achieve the Plan goals and timetables.
 4. The Contractor shall implement the specific affirmative action standards provided in paragraphs 7a through p of these specifications. The goals set forth in the solicitation from which this contract resulted are expressed as percentages of the total hours of employment and training of minority and female utilization the Contractor should reasonably be able to achieve in which it has employees in each construction trade in which it has employees in the covered area. Covered construction contractors performing construction work in geographical areas where they do not have a Federal or federally assisted construction contract shall apply the minority and female goals established for the geographical area where the work is being performed. Goals are published periodically in the Federal Register in notices form and such notices may be obtained from any Office of Federal Contract Compliance Programs office or from Federal procurement contracting officers. The Contractor is expected to make substantially uniform progress toward its goals in each craft during the period specified.
 5. Neither the provisions of any collective bargaining agreement, nor the failure by a union with whom the Contractor has a collective bargaining agreement to refer either minorities or women shall excuse the Contractor's obligations under these specifications, Executive Order 11246, or the regulations promulgated pursuant thereto.
 6. In order for the non-working training hours of apprentices and trainees to be counted in meeting the goals, such apprentices and trainees must be employed by the Contractor during the training period, and the Contractor must have made a commitment to employ the apprentices and trainees at the completion of their training, subject to the availability of employment opportunities. Trainees must be trained pursuant to training programs approved by the U. S. Department of Labor.
 7. The Contractor shall take specific affirmative actions to ensure equal employment opportunity. The evaluation of the Contractor's compliance with these specifications shall be based upon its effort to achieve maximum results from its actions. The Contractor shall document these efforts fully, and shall implement affirmative action steps at least as extensive as the following:
 - a. Ensure and maintain a working environment free of harassment, intimidation, and coercion at all sites, and in all facilities at which the Contractor's employees are assigned to work. The Contractor where possible, will assign two or more women to each construction project. The Contractor shall specifically ensure that all foremen, superintendents and other on-site supervisory personnel are aware of and carry out the Contractor's obligation to maintain such a working environment, with specific attention to minority of female individuals working at such sites or in such facilities.
 - b. Establish and maintain a current list of minority and female recruitment sources, provide written notification to minority recruitment sources and to community organizations when the Contractor or its unions have employment opportunities available and maintain a record of the organization's responses.
- c. Maintain a current file of the names, addresses and telephone numbers of each minority and female off-the-street applicant and minority or female referral from a union, a recruitment source or community organization and of what action was taken with respect to each individual. If such individual was sent to the union hiring hall for referral and was not referred back to the Contractor by the union or, if referred, not employed by the Contractor, this shall be documented in the file with the reason therefor, along with whatever additional actions the Contractor may taken.
 - d. Provide immediate written notification to the Director when union or unions with which the Contractor has a collective bargaining agreement has not referred to the Contractor a minority person or woman sent by the Contractor, or when the Contractor has other information that the union referral process has impeded the Contractor's efforts to meet his obligations.
 - e. Develop on-the-job training opportunities and/or participate in training programs for the area which expressly include minorities and women, including upgrading programs and apprenticeship and trainee programs relevant to the Contractor's employment needs, especially those programs funded by the Department of Labor. The Contractor shall provide notice of these programs to the sources compiled under 7b above.
 - f. Disseminate the Contractor's EEO policy to unions and training programs and requesting their cooperation in assisting the Contractor in meeting its EEO obligations; by including it in any policy manual and collective bargaining agreement; by publicizing it in the company newspaper, annual report, etc.; by specific review of the policy with all management personnel and with all minority and female employees at least once a year; and by posting the company EEO policy on bulletin boards accessible to all employees at each location where construction work is performed.
 - g. Review at least annually, the company's EEO policy and affirmative action obligations under these specifications with all employees having any responsibility for hiring, assignment, layoff, termination or other employment decisions including specific review of these items with on-site supervisory personnel such as Superintendents, General Foremen, etc., prior to the initialization of construction work at any job site. A written record shall be made and maintained identifying the time and place of these meetings, persons attending, subject matter discussed, and disposition of the subject matter.
 - h. Disseminate the Contractor's EEO policy externally by including it in any advertising in the news media, specifically including minority and female news media, and providing written notification to and discussing the Contractor's EEO policy with other Contractors and Subcontractors with whom the Contractor does or anticipates doing business.
 - i. Direct its recruitment efforts, both oral and written, to minority, female and community organizations, to schools with minority and female students and to minority and female recruitment and training organizations serving the Contractor's recruitment area and employment needs. Not later than one month prior to the date for the acceptance of applications for apprenticeship or other training by any recruitment source, the Contractor shall sent written notification to organizations such as the above, describing the openings, screening procedures and tests to be used in the selection process.
 - j. Encourage present minority and female employees to recruit other minority persons and women and where reasonable, provide after school, summer, and vacation

EXHIBIT 6 - FEDERAL AID PROVISIONS

- employment to minority and female youth both on the site and in other areas of a Contractor's work force.
- k. Validate all tests and other selection requirements where there is an obligation to do so under 41 CFR Part 60-3.
 - l. Conduct, at least annually, an inventory and evaluation at least of all minority and female personnel for promotional opportunities and encourage these employees to seek or to prepare for, through appropriate training, etc., such opportunities.
 - m. Ensure that all seniority practices, job classifications, work assignments and other personnel practices, do not have a discriminatory effect by continually monitoring all personnel and employment related activities to ensure that the EEO policy and the Contractor's obligations under these specifications are being carried out.
 - n. Ensure that all facilities and company activities are non-segregated except that separate or single-user toilet and necessary changing facilities shall be provided to assure privacy between the sexes.
 - o. Document and maintain a record of all solicitations of offers for subcontracts from minority and female construction contractors and suppliers, including circulation of solicitations to minority and female contractor associations and other business associations.
 - p. Conduct a review, at least annually of all supervisors' adherence to and performance under the Contractor's EEO policies and affirmative action obligations.
8. Contractors are encouraged to participate in voluntary associations which assist in fulfilling one or more of their affirmative action obligations (7a through p). The efforts of a contractor association joint contractor-union, contractor-community, or other similar group of which the Contractor is a member and participant, may be asserted as fulfilling any one or more of its obligations under 7a through p of these specifications provided that the contractor actively participates in the group, makes every effort to assure that the group has a positive impact on the employment of minorities and women in the industry, ensures that the concrete benefits of the program are reflected in the contractor's minority and female work force participation, makes a good faith effort to meet its individual goals and timetables, and can provide access to documentation which demonstrates the effectiveness of actions taken on behalf of the Contractor. The obligation to comply, however, is the Contractor's and failure of such a group to fulfill an obligation shall not be a defense for the Contractor's noncompliance.
 9. A single goal for minorities and a separate single goal for women have been established. The Contractor, however, is required to provide equal employment opportunity and take affirmative action for all minority groups, both male and female, and all women, both minority and non-minority. Consequently, the Contractor may be in violation of the Executive Order if a particular group is employed in a substantially disparate manner (for example, even though the Contractor may be in violation of the Executive Order if a specific minority group of women is underutilized).
 10. The Contractor shall not use the goals and timetables or affirmative action standards to discriminate against any person because of race, color, religion, sex, or national origin.
 11. The Contractor shall not enter into any Subcontract with any person or firm debarred from the Government contracts pursuant to the executive Order 11246.
 12. The Contractor shall carry out such sanctions and penalties for violation of these specifications and the Equal Opportunity Clause, including suspensions, termination and cancellation of the existing subcontracts as may be imposed or ordered pursuant to Executive Order 11246, as amended. and its implementing regulations, by the Office if the Federal Compliance Programs. Any Contractor who fails to carry out such sanctions and penalties shall be in violation of the specifications and Executive Order 11246, as amended.
 13. The Contractor, in fulfilling its obligations under these specifications, shall implement specific affirmative action steps, at least as extensive as those standards prescribed in paragraph 7 of these specifications, so as to achieve maximum results from its efforts to ensure equal employment opportunity. If the Contractor fails to comply with the requirements of the executive Order, the implementing regulations, or these specifications, the Director shall proceed in accordance with 41 CFR 60-4-8.
 14. The Contractor shall designate a responsible official to monitor all employment related activity to ensure that the company EEO policy is being carried out, to submit reports relating to the provisions hereof as may be required by the Government and to keep records. Records shall at least include for each employee the name, address, telephone numbers, construction trade, union affiliation if any employee identification number when assigned, social security number, race, sex status(e.g., Mechanic, apprentice, trainee, helper, or laborer), dates of changes in status, hours worked per week in the indicated trade, rate of pay, and location at which the work was performed. Records shall be maintained in an easily understandable and retrievable form; however, to the degree that the existing records satisfy this requirement, contractors shall not be required to maintain separate records.
 15. Nothing herein provided shall be construed as a limitation upon the application of other laws which establish different standards of compliance or upon the application of requirements for the hiring of local or other area residents(e.g. those under the Public Works Employment Act of 1977 and the Community Development Block Grant Program).

EXHIBIT 6 - FEDERAL AID PROVISIONS

General Decision Number: SC150042 01/02/2015 SC42

Superseded General Decision Number: SC20140042

State: South Carolina

Construction Type: Highway

Counties: Calhoun, Fairfield, Kershaw, Lexington, Richland and Saluda Counties in South Carolina.

HIGHWAY CONSTRUCTION PROJECTS (excluding tunnels, building structures in rest area projects & railroad construction; bascule, suspension & spandrel arch bridges designed for commercial navigation, bridges involving marine construction; and other major bridges).

Note: Executive Order (EO) 13658 establishes an hourly minimum wage of \$10.10 for 2015 that applies to all contracts subject to the Davis-Bacon Act for which the solicitation is issued on or after January 1, 2015. If this contract is covered by the EO, the contractor must pay all workers in any classification listed on this wage determination at least \$10.10 (or the applicable wage rate listed on this wage determination, if it is higher) for all hours spent performing on the contract. The EO minimum wage rate will be adjusted annually. Additional information on contractor requirements and worker protections under the EO is available at www.dol.gov/whd/govcontracts.

Modification Number	Publication Date
0	01/02/2015

SUSC2011-033 09/15/2011

	Rates	Fringes
CARPENTER (Form Work Only)		
Fairfield, Kershaw,		
Richland, Saluda.....	\$ 15.04	
Lexington.....	\$ 14.50	
CEMENT MASON/CONCRETE FINISHER...	\$ 13.65	
GUARDRAIL INSTALLER(Includes Guardrail/Post Driver Work).....	\$ 12.49	
IRONWORKER, REINFORCING.....	\$ 15.02	
LABORER		
Asphalt Includes Asphalt Distributor, Shoveler, and Spreader.....	\$ 11.54	
Common or General		
Calhoun.....	\$ 10.09	
Fairfield.....	\$ 9.55	

EXHIBIT 6 - FEDERAL AID PROVISIONS

Kershaw.....	\$ 9.88
Lexington.....	\$ 9.78
Richland.....	\$ 9.97
Saluda.....	\$ 9.88
Luteman.....	\$ 11.61
Mason Tender-	
Cement/Concrete.....	\$ 10.40
Pipelayer.....	\$ 14.46
Traffic Control-Cone Setter	
Calhoun, Fairfield,	
Kershaw, Richland, Saluda..	\$ 10.87
Lexington.....	\$ 11.26
Traffic Control-Flagger.....	\$ 11.07

POWER EQUIPMENT OPERATOR:

Backhoe/Excavator/Trackhoe	
Calhoun, Fairfield,	
Kershaw, Richland, Saluda..	\$ 15.98
Lexington.....	\$ 16.02
Bulldozer.....	\$ 17.38
Crane.....	\$ 18.93
Grader/Blade	
Calhoun, Fairfield,	
Kershaw, Richland, Saluda..	\$ 18.44
Lexington.....	\$ 18.54
Hydroseeder.....	\$ 11.00
Loader (Front End).....	\$ 17.22
Mechanic.....	\$ 15.25
Milling Machine.....	\$ 11.84
Paver.....	\$ 13.93
Roller	
Calhoun, Fairfield,	
Kershaw, Richland, Saluda..	\$ 14.98
Lexington.....	\$ 15.10
Scraper.....	\$ 12.71
Screed.....	\$ 13.56
Tractor.....	\$ 13.28

TRUCK DRIVER

Dump Truck	
Calhoun, Fairfield,	
Kershaw, Richland, Saluda..	\$ 13.29
Lexington.....	\$ 13.22
Lowboy Truck.....	\$ 14.11

WELDERS - Receive rate prescribed for craft performing operation to which welding is incidental.

=====

Unlisted classifications needed for work not included within the scope of the classifications listed may be added after award only as provided in the labor standards contract clauses (29CFR 5.5 (a) (1) (ii)).

The body of each wage determination lists the classification and wage rates that have been found to be prevailing for the cited type(s) of construction in the area covered by the wage determination. The classifications are listed in alphabetical order of "identifiers" that indicate whether the particular rate is a union rate (current union negotiated rate for local), a survey rate (weighted average rate) or a union average rate (weighted union average rate).

Union Rate Identifiers

A four letter classification abbreviation identifier enclosed in dotted lines beginning with characters other than "SU" or "UAVG" denotes that the union classification and rate were prevailing for that classification in the survey. Example: PLUM0198-005 07/01/2014. PLUM is an abbreviation identifier of the union which prevailed in the survey for this classification, which in this example would be Plumbers. 0198 indicates the local union number or district council number where applicable, i.e., Plumbers Local 0198. The next number, 005 in the example, is an internal number used in processing the wage determination. 07/01/2014 is the effective date of the most current negotiated rate, which in this example is July 1, 2014.

Union prevailing wage rates are updated to reflect all rate changes in the collective bargaining agreement (CBA) governing this classification and rate.

Survey Rate Identifiers

Classifications listed under the "SU" identifier indicate that no one rate prevailed for this classification in the survey and the published rate is derived by computing a weighted average rate based on all the rates reported in the survey for that classification. As this weighted average rate includes all rates reported in the survey, it may include both union and non-union rates. Example: SULA2012-007 5/13/2014. SU indicates the rates are survey rates based on a weighted average calculation of rates and are not majority rates. LA indicates the State of Louisiana. 2012 is the year of survey on which these classifications and rates are based. The next number, 007 in the example, is an internal number used in producing the wage determination. 5/13/2014 indicates the survey completion date for the classifications and rates under that identifier.

Survey wage rates are not updated and remain in effect until a new survey is conducted.

Union Average Rate Identifiers

EXHIBIT 6 - FEDERAL AID PROVISIONS

Classification(s) listed under the UAVG identifier indicate that no single majority rate prevailed for those classifications; however, 100% of the data reported for the classifications was union data. EXAMPLE: UAVG-OH-0010 08/29/2014. UAVG indicates that the rate is a weighted union average rate. OH indicates the state. The next number, 0010 in the example, is an internal number used in producing the wage determination. 08/29/2014 indicates the survey completion date for the classifications and rates under that identifier.

A UAVG rate will be updated once a year, usually in January of each year, to reflect a weighted average of the current negotiated/CBA rate of the union locals from which the rate is based.

WAGE DETERMINATION APPEALS PROCESS

1.) Has there been an initial decision in the matter? This can be:

- * an existing published wage determination
- * a survey underlying a wage determination
- * a Wage and Hour Division letter setting forth a position on a wage determination matter
- * a conformance (additional classification and rate) ruling

On survey related matters, initial contact, including requests for summaries of surveys, should be with the Wage and Hour Regional Office for the area in which the survey was conducted because those Regional Offices have responsibility for the Davis-Bacon survey program. If the response from this initial contact is not satisfactory, then the process described in 2.) and 3.) should be followed.

With regard to any other matter not yet ripe for the formal process described here, initial contact should be with the Branch of Construction Wage Determinations. Write to:

Branch of Construction Wage Determinations
Wage and Hour Division
U.S. Department of Labor
200 Constitution Avenue, N.W.
Washington, DC 20210

2.) If the answer to the question in 1.) is yes, then an interested party (those affected by the action) can request review and reconsideration from the Wage and Hour Administrator (See 29 CFR Part 1.8 and 29 CFR Part 7). Write to:

Wage and Hour Administrator
U.S. Department of Labor
200 Constitution Avenue,
N.W. Washington, DC 20210

EXHIBIT 6 - FEDERAL AID PROVISIONS

The request should be accompanied by a full statement of the interested party's position and by any information (wage payment data, project description, area practice material, etc.) that the requestor considers relevant to the issue.

3.) If the decision of the Administrator is not favorable, an interested party may appeal directly to the Administrative Review Board (formerly the Wage Appeals Board). Write to:

Administrative Review Board
U.S. Department of Labor
200 Constitution Avenue,
N.W. Washington, DC 20210

4.) All decisions by the Administrative Review Board are final.

=====

END OF GENERAL DECISION

EXHIBIT 6 - FEDERAL AID PROVISIONS

May 22, 1997

Project ID P027002

DISADVANTAGED BUSINESS ENTERPRISES (DBE)
COMMITTAL SHEET

Information must be shown on this sheet as required by the supplemental specifications entitled "Instructions to Bidders - Federal Projects" and "Disadvantaged Business Enterprises (DBE) - Federal Projects" included in this proposal.

FAILURE TO PROVIDE ALL INFORMATION REQUIRED ON THIS FORM MAY RESULT IN THE AWARD BEING MADE TO THE NEXT LOWEST RESPONSIBLE BIDDER.

¹ Name & Address of DBE's (Subcontractor or Supplier)	² Percent	³ Description of Work and Approximate Quantity ⁶ (show percent when appropriate)				⁵ Dollar Value
		Item	Qty.	Unit	⁴ Unit Price	

- ¹ The designation of Firm A and/or B is not considered acceptable. I hereby certify that this company has communicated with and received quotes from the DBE's listed above and that they are willing to perform the work as listed above and that this company is committed to utilizing the above firm(s) on this contract.
- ² Percent - show percent of total contract amount committed to each DBE listed.
- ³ All information requested must be included unless item is listed in proposal on a lump sum basis.
- ⁴ Unit Price - show unit price quoted by DBE.
- ⁵ Dollar Value - extended amount based on Quantity and Unit Price.
- ⁶ Applies to lump sum items only.

This form may be reproduced or additional sheets added in order to provide all requested information. (See *Instructions to Bidders - Federal Projects*).

SWORN to before me this _____ day of _____, 20_____

Company

(Seal)

By: _____

Notary Public for _____

Title: _____

My commission expires: _____

EXHIBIT 7

ESCROW DOCUMENTS

EXHIBIT 7 – ESCROW PROPOSAL DOCUMENTS

Escrow Proposal Documents shall comply with the SCDOT Escrow Bid Documentation Supplemental Specification. In this Supplemental Specification, the term “bid” shall be replaced with “proposal.”

ESCROW AGREEMENT
FOR
CONTRACT PROPOSAL DOCUMENTS

~~THIS AGREEMENT is made and entered into this ____ day of _____, 2015, by and among the South Carolina Department of Transportation, an agency of the State of South Carolina, hereinafter called the “DEPARTMENT”, _____, hereinafter call the “CONTRACTOR”, and Wachovia Bank, NA, hereinafter called the “ESCROW AGENT”;~~

~~WHEREAS, the DEPARTMENT and CONTRACTOR entered into that certain Construction Contract dated _____, hereinafter called the “CONTRACT”, for the construction of SC File No.932.038170, pursuant to which the CONTRACTOR shall cause the work herein to be constructed; and~~

~~WHEREAS, the DEPARTMENT and CONTRACTOR are desirous of entering into an Escrow Agreement, to provide for specific contingencies governing the escrow and control of Contract Proposal Documentation; hereinafter called “PROPOSAL DOCUMENTS”; and~~

~~WHEREAS, the DEPARTMENT and CONTRACTOR desire the ESCROW AGENT to hold the PROPOSAL DOCUMENTS of the CONTRACTOR;~~

~~NOW, THEREFORE, for and in consideration of the mutual covenants contained herein, it is agreed by and between the parties hereto that:~~

ARTICLE I
ESCROW OF THE CONTRACT PROPOSAL DOCUMENTATION

~~The parties hereto agree to the establishment of Escrow of the PROPOSAL DOCUMENTS for the CONTRACT pursuant to the DEPARTMENT’S Standard Specifications for Highway Construction (Edition of 2007), and Supplemental Specifications or Special Provisions pertaining to construction under the CONTRACT. It is the understanding of the parties hereto that the DEPARTMENT shall pay the ESCROW AGENT, as determined by separate Agreement, for the escrow of the PROPOSAL DOCUMENTS submitted to the ESCROW AGENT under the terms of this Agreement.~~

ARTICLE II
ACKNOWLEDGEMENT

~~By its signature below, the ESCROW AGENT hereby acknowledges receipt from the DEPARTMENT and CONTRACTOR of a sealed container bearing the CONTRACTOR’S name,~~

EXHIBIT 7 – ESCROW PROPOSAL DOCUMENTS

address, and CONTRACT File Number(s) assigned by the DEPARTMENT and containing the CONTRACT PROPOSAL DOCUMENTS.

**ARTICLE III
DEPOSIT OF PROPOSAL DOCUMENTS**

The CONTRACT PROPOSAL DOCUMENTS shall remain on deposit with the ESCROW AGENT until those conditions of release, as specified in ARTICLE IV “RELEASE FROM ESCROW”, are met. As long as the PROPOSAL DOCUMENTS remain in escrow with the ESCROW AGENT, the ESCROW AGENT shall not allow any person access, to gain possession, or in any way to interfere with the sealed PROPOSAL DOCUMENT container.

**ARTICLE IV
RELEASE FROM ESCROW**

Upon being presented with documentation from the DEPARTMENT, signed by the Contracts Engineer, that the Final Estimate for the CONTRACT has been paid to the CONTRACTOR and the warranty period of the CONTRACT has expired, the ESCROW AGENT shall deliver to the CONTRACTOR the sealed container bearing the CONTRACTOR’s name and address and File Number(s) on it. The ESCROW AGENT is also authorized to release the CONTRACT PROPOSAL DOCUMENT sealed container to the DEPARTMENT without the CONTRACTOR’s signed consent subject to written documentation, signed by the DEPARTMENT’s Contracts Engineer, that one or both of the following conditions have occurred:

1. The CONTRACTOR has filed a claim against the DEPARTMENT related to the project.
2. The CONTRACTOR has initiated litigation against the DEPARTMENT relating to the CONTRACT.

Prior to any release from escrow to the DEPARTMENT, the ESCROW AGENT shall provide written notice to the CONTRACTOR of the ESCROW AGENT’s intention to release the CONTRACT PROPOSAL DOCUMENTS sealed container to the DEPARTMENT. Such written notice from the ESCROW AGENT shall be sent by certified mail no less than ten (10) calendar days prior to release of the CONTRACT PROPOSAL DOCUMENTS sealed container to the DEPARTMENT. Upon any release from escrow of the CONTRACT PROPOSAL DOCUMENT sealed container, the party receiving the sealed container shall sign Exhibit A, ESCROW RELEASE FOR CONTRACT PROPOSAL DOCUMENTS, as attached hereto and incorporated herein as if fully contained, by the party receiving the PROPOSAL DOCUMENT container.

**ARTICLE V
INDEMNITY**

EXHIBIT 7 – ESCROW PROPOSAL DOCUMENTS

The CONTRACTOR agrees to indemnify and hold the ESCROW AGENT harmless against any loss, claim, damage, liability or expenses incurred in connection with any action, suit, proceeding, claim or alleged liability arising from this Escrow Agreement, provided, however, that the ESCROW AGENT shall not be so indemnified or held harmless for the negligence or acts of bad faith by it or any of its agents or employees.

**ARTICLE VI
NOTICES**

All notices and other communication shall be in writing and shall be deemed to have been duly given and delivered if mailed, return receipt requested, postage prepaid to the addresses stated herein.

DEPARTMENT:

Contracts Administration, Room 334
South Carolina Department of Transportation
955 Park Street
Columbia, SC 29201

CONTRACTOR:

Name
Street
City, State Zip Code

ESCROW AGENT:

Wachovia Bank, NA
Corporate Trust Group
1426 Main Street, 17th Floor
Columbia, SC 29201

**ARTICLE VII
DUTIES OF ESCROW AGENT**

The duties and responsibilities of the ESCROW AGENT shall be limited to those expressly set forth herein and the ESCROW AGENT shall act only in accordance with this Escrow Agreement. Notwithstanding specific provisions hereunder, the ESCROW AGENT shall at all times act upon and in accordance with the joint written instructions of the DEPARTMENT and CONTRACTOR.

**ARTICLE VIII
LAWS**

This Escrow Agreement shall be deemed to have been executed in RICHLAND County, South Carolina and the laws of the State of South Carolina shall apply.

**ARTICLE IX
ASSIGNMENT**

EXHIBIT 7 – ESCROW PROPOSAL DOCUMENTS

This Escrow Agreement shall not be assigned without the written consent of all the parties hereto.

**ARTICLE X
SURVIVAL OF CONTRACT**

Except as may be expressly modified, all terms and conditions of this Escrow Agreement remain in full force and effect. The establishment of this Escrow Agreement is limited solely by the contingency of release of the CONTRACT PROPOSAL DOCUMENTS sealed container by the CONTRACTOR to the DEPARTMENT, as established by ARTICLE IV, RELEASE FROM ESCROW. Nothing contained herein shall alter the rights of the parties hereto.

The covenants herein contained shall, except as otherwise provided, accrue to the benefit of and be binding upon the successors and assigns of the parties hereto.

IN WITNESS WHEREOF, the parties have hereunto set their hands and seals the day above first written.

CONTRACTOR

ESCROW AGENT

Wachovia Bank, NA

By: _____ (Seal) By: _____

Representative of CONTRACTOR

Witness

Witness

DEPARTMENT

By: _____

Contracts Engineer

Witness

EXHIBIT 7 – ESCROW PROPOSAL DOCUMENTS

Exhibit A

ESCROW RELEASE FOR CONTRACT PROPOSAL DOCUMENTS

This is to certify that on this _____ day of _____, 2015, the sealed container holding the PROPOSAL DOCUMENTS for the following CONTRACT was released from escrow:

Proposal ID: P027002

CONTRACTOR:

Address:

Date PROPOSAL DOCUMENTS put into Escrow:

The Representative for the ESCROW AGENT identified below, personally transferred the sealed container holding the PROPOSAL DOCUMENTS to the Representative for the CONTRACTOR or the DEPARTMENT.

Acknowledgment of Release:

(Print Name)

Signature of Representative for Wachovia Bank, NA

The individual named below acknowledges receipt of the sealed container holding the PROPOSAL DOCUMENTS.

Acknowledgment of Receipt:

(Print Name)

Signature of Representative for

If the CONTRACTOR receives the sealed container holding the PROPOSAL DOCUMENTS, the ESCROW AGENT will send a signed copy of this document to the DEPARTMENT.

EXHIBIT 7a

ESCROW RELEASE

ESCROW RELEASE FOR CONTRACT BID DOCUMENTS

FOR

**WIDENING AND REHABILITATION OF I-77
FROM MM 15 TO MM 27**

RICHLAND COUNTY

The *Escrow Release for Contract Bid Documents*, as submitted by the selected PROPOSER, will be included with the completed agreement.

EXHIBIT 7b

ESCROW AGREEMENT

ESCROW AGREEMENT FOR CONTRACT BID DOCUMENTS

FOR

**WIDENING AND REHABILITATION OF I-77
FROM MM 15 TO MM 27**

RICHLAND COUNTY

The Escrow Agreement for Contract Bid Documents, as submitted by the selected PROPOSER, will be included with the completed agreement.

EXHIBIT 8

RAILROAD INFORMATION

1. General Information

The I-77 mainline present right-of-way intersects CSX Transportation (CSXT), formerly Seaboard Coast Line Railroad, right-of-way at approximate railroad milepost S 350. The CSXT facilities pass over the I-77 travel lanes via an existing bridge. SCDOT records indicate that this CSXT location currently has six total trains per day with two of those being Amtrak trains. The maximum speed of the trains is 60 miles per hour. SCDOT and CSXT have an existing agreement for this location. The CSXT Agreement, dated January 18, 1980, is provided in Attachment B.

The I-77 mainline present right-of-way intersects Norfolk Southern Railroad (NSR) right-of-way at approximate railroad milepost R 98.88. The NSR facilities pass over the I-77 travel lanes via an existing bridge. No existing agreement is identified for this location.

2. Railroad Coordination

SCDOT anticipates that no revisions, at these locations will be required. SCDOT is actively coordinating with the Railroads regarding these existing locations. If the Contractor's proposed plan impacts locations outside of the limits shown on the existing plans for these locations, the Contractor shall be responsible for all railroad coordination and conditions related to those impacts. The Contractor shall forward all railroad coordination materials through SCDOT.

Based on previous coordination, SCDOT expects the following requirements for this Project:

1. **CSXT Coordination**

SCDOT and CSXT expect that the Project can be completed under the terms of the existing agreement with CSXT. The CONTRACTOR shall comply with the terms of the existing CSXT agreement and the CSXT Standard Special Provisions including, but not limited to, acquiring Railroad Protective Liability Insurance and notifying CSXT prior to beginning work in the CSXT right-of-way. A flagman is not required for work within the confines of the existing agreement with CSXT. The CONTRACTOR shall be responsible for any deviations from or modifications to the existing agreement with CSXT. The CONTRACTOR's attention is called to Attachment B with which includes a copy of the existing agreement with CSXT, the CSXT Standard Special Provisions, and the CSXT Transportation Public Project Information document.

2. **Norfolk Southern Coordination**

SCDOT anticipates that a NS Construction Agreement will be required. The CONTRACTOR shall obtain the NS Construction Agreement through SCDOT. SCDOT anticipates that a flagman will be required, that the proposed plans will

EXHIBIT 8 – RAILROAD INFORMATION

have to be submitted to NS, and that NS will conduct several inspections during the project. The CONTRACTOR's attention is called to Attachment B which includes a copy of the existing NS Valuation Map V-36/22 and the NS response to the Request for Railroad Engineering Requirements for Inclusion into Design-Build Project Bid Package. SCDOT will continue to coordinate with NS and will provide any updated information when received.