

**South Carolina Department of
Transportation**

REQUEST FOR PROPOSALS

Replacement of SC 41 Bridge over Wando River

Federal Aid Project No. BR88(079)
File No. 8.158B & 10.032100

A Design-Build Project

Charleston and Berkeley Counties
South Carolina

September 27, 2013

This Page Intentionally Left Blank

INDEX

Replacement of SC 41 Bridge over the Wando River

Design-Build Project

Charleston & Berkeley Counties

Federal Aid Project No. BR88(079)

File No. 8.158B & 10.032100

INDEX

Request for Proposals

Attachment A – Agreement

- Exhibit 1. Cost Proposal Bid Form
- Exhibit 2. Schedule of Values
- Exhibit 3. Scope of Work
- Exhibit 4. Project Design Criteria
 - 4a. Roadway
 - 4b. Structures
 - 4c. Pavement
 - 4d. Traffic
 - Part 1 – Signing and Pavement Markings
 - Part 2 – Work Zone Traffic Control
 - Part 3 – Traffic Signals
 - 4e. Hydraulic
 - 4f. Geotechnical
- Exhibit 5. Special Provisions
- Exhibit 6. Supplemental Specifications
- Exhibit 7. Federal-Aid Project Supplemental Specifications
- Exhibit 8. Environmental Information
- Exhibit 9. Escrow Documents

Attachment B – Project Information Package

REQUEST FOR PROPOSALS

South Carolina Department of Transportation

REQUEST FOR PROPOSALS

A DESIGN-BUILD PROJECT

Federal Aid Project No. BR88(079)
File Nos. 8.158B & 10.032100

SC Route 41 Bridge Replacement Over the Wando River

Berkeley and Charleston Counties, South Carolina

September 26, 2013

TABLE OF CONTENTS

I.	PURPOSE OF REQUEST FOR PROPOSALS	3
II.	OVERVIEW	3
	Project Description	3
	Project Information	4
	Schedule and Liquidated Damages.....	4
	RFP Committal	4
	Disadvantage Business Enterprises	4
	On-The-Job Training Requirement	5
III.	GENERAL INSTRUCTIONS	5
	RFP for Industry Review.....	5
	Questions and Clarifications.....	5
	Confidential One-on-One Meetings.....	5
	Alternative Technical Concepts.....	6
	Stipends.....	11
	Proposal Submittal.....	11
IV.	PROJECT SCOPE	11
V.	PROPOSAL DEVELOPMENT	12
	Technical Proposal	12
	Cost Proposal	14
	Confidentiality of Proposals	14
	Non-Collusion and EEO Certification.....	14
VI.	EVALUATION OF PROPOSALS.....	14
	Proposal Review Committee	14
	Proposal Review	14
	Technical Evaluation	15
	Presentations	16
	Clarifications	16
	Opening of Cost Proposals.....	16
	Total Adjusted Bid Determination.....	17
VII.	SELECTION OF CONTRACTOR	17
VIII.	GENERAL INFORMATION	18
IX.	MILESTONES	20
X.	COST PROPOSAL BID FORM	21
XI.	NON-COLLUSION AND EEO CERTIFICATIONS.....	22
XII.	STIPEND ACKNOWLEDGEMENT FORM.....	24
XIII.	STIPEND AGREEMENT.....	25

Attachment A – Agreement

Attachment B – Project Information Package

I. PURPOSE OF REQUEST FOR PROPOSALS

The South Carolina Department of Transportation (SCDOT) in cooperation with the Federal Highway Administration (FHWA) seeks to replace the existing SC 41 swing-span bridge over the Wando River with a fixed-span type structure with 55 feet of vertical clearance. The project will include all items detailed in Exhibit 3 (Scope of Work). The project will be procured and constructed using the Design-Build Procurement method. The purpose of this Request for Proposals (“RFP”) is to select a PROPOSER to perform the project services described in this RFP. SCDOT desires that this project be constructed in a very efficient and timely manner. The proposed project services are hereinafter referred to as the “Project”. “PROPOSER,” as used here, includes a firm or firms, consortia, partnerships, joint ventures, and other legal entities, which have been requested by SCDOT to submit a Proposal in response to this RFP.

It is not the intention of the SCDOT to receive complete detailed project analysis and design prior to the selection of a PROPOSER and the later execution of an agreement. Rather, the response to this RFP shall provide sufficient information to be evaluated to determine if the proposal is in accordance with the specified process and criteria. The Proposal shall be specific enough on assumptions used in its preparation so as to provide the basis for determining a final agreement.

The information obtained under this RFP will become the property of SCDOT without restriction or limitation on its use. With the exception of Alternative Technical Concepts (ATCs), SCDOT shall have unrestricted authority to publish, disclose, distribute, or otherwise use in whole or in part any reports, data, or other materials prepared under this RFP. SCDOT shall retain ownership of all plans, specifications, and related documents.

II. OVERVIEW

Project Description

The purpose of this project is to replace the existing swing-span bridge with a fixed-span type structure with 55 feet of vertical clearance including roadway approach work, and to realign SC 41 and relocate the existing SC 41 and S-08-33 (Clements Ferry Road) intersection.

SCDOT intends to enter into a contract, for services as detailed in Exhibit 3 (Scope of Work):

The PROPOSER shall be responsible for meeting all Project requirements, specifications, and other applicable criteria as set forth in “Attachments A and B”. If modifications to the plans produced by the proposer are required by the PROPOSER, the PROPOSER shall be responsible for these modifications, any associated permit modifications, right-of-way, utility impacts, and cost thereof. All modifications must meet or exceed the Project requirements.

Project Information

A Project Information CD, containing electronic information applicable to the Project, will be supplied to PROPOSERS. The Project Information Package will include information describing the work, which has been performed by SCDOT prior to entering into the contract for the Project. The Project Information Package is attached to this RFP as “Attachment B”.

PROPOSERS are encouraged to visit the project site and to make any additional subsurface explorations or soil tests that PROPOSER may desire for purposes of preparing the Proposal. The PROPOSER shall obtain any permits or permissions required prior to any additional subsurface exploration.

Schedule and Liquidated Damages

It is the intent of SCDOT to complete the Project in a timely manner with minimum interference to normal traffic operations. Liquidated damages shall be assessed in accordance with Article IV of the Agreement.

SCDOT has established a Time for Completion of Project of 1277 days. The full notice to proceed shall be no later than 45 days from the effective date of the Agreement. The Time for Completion of Project includes a 12 month timeframe from the submittal to SCDOT of a complete and acceptable 404 permit application to SCDOT’s receipt of all permits described in Environmental Permitting Information dated 4-15-13 included in Attachment B. SCDOT will only consider time extensions beyond this 12 month timeframe subject to the provisions in Article IX of the Agreement.

RFP Committal

The submittal of a Proposal in response to this RFP shall constitute the PROPOSER’S agreement to enter into a contract with SCDOT for the completion of the Project under the terms set forth in the Agreement attached hereto as “Attachment A”.

Disadvantaged Business Enterprises

The contract for this Project contains a DBE goal of seven and one-half percent (7.5%) of the contract price. PROPOSER shall submit a DBE Committal Sheet, as provided in Exhibit 7, with their response to this RFP in a separate sealed Cost Proposal packet. PROPOSER is required to calculate the percentage of its total goal/committal for this Project on the DBE Committal Sheet. Submission of the DBE committal sheet is a requirement of this RFP. Failure to submit the DBE committal sheet will deem the Proposal non-responsive and the Proposal shall be rejected.

On-The-Job Training Requirement

The Contract for this Project contains an On-The-Job Training Requirement. The number of persons to be trained under the On-the-Job Training Program during this Project is six (6) for Bridge. The PROPOSER shall comply with the requirements of Attachment A, Exhibit 7. The Proposer shall submit its plan for On-the-Job Training to SCDOT for written approval prior to commencing construction activities.

III. GENERAL INSTRUCTIONS

RFP for Industry Review

It is the intent of SCDOT to issue an RFP for industry review during the initial stages of this RFP process to allow industry review and comment. After completion of the written clarifications/comment stage as set forth below, a Final RFP will be issued. PROPOSER shall submit their responses to the Final RFP in accordance with the Milestone Schedule.

Questions and Clarifications

Once the RFP for industry review is issued, the PROPOSERS may submit questions or seek clarification relating to the RFP. Questions or requests for clarification shall be in writing and must be received by SCDOT in accordance with the Milestone Schedule. SCDOT reserves the right to accept or not accept questions received after the milestone deadlines. Changes made to the RFP for Industry Review as a result of the written questions will be tracked by highlighting the changes in the Final RFP. Verbal responses from SCDOT are for information only and not binding.

Questions or clarifications concerning the RFP or Project shall be directed to:

Mr. Matthew R. Lifsey, P.E.
SCDOT Point of Contact (POC)
South Carolina Department of Transportation
955 Park Street, Room 402
Post Office Box 191
Columbia, South Carolina 29202-0191
803-737-1598
LifseyMR@scdot.org

Confidential One-On-One Meetings

Once the Final/Revised RFP is issued, SCDOT will schedule one-on-one meetings at the request of the PROPOSERS. By the date specified in the Project Milestones, PROPOSER shall submit

written questions and topics for discussion and request a meeting in writing addressed to Matthew R. Lifsey at the above address. The purpose of the confidential one-on-one meetings is to provide the PROPOSER the opportunity to confidentially discuss the contents of his proposal with SCDOT personnel. Preliminary Concepts may be discussed during the Confidential One-on-One Meetings. SCDOT will determine if questions submitted to or asked at the one-on-one meetings are considered confidential. No additional time will be allowed to research answers. Nothing discussed at the one-on-one meetings shall change the requirements in the RFP. SCDOT will answer the questions at the meeting verbally if possible. Verbal responses are for information only and are not binding. If necessary, written responses that are determined to be of a non-confidential nature will be provided in an addendum to the RFP.

Alternative Technical Concepts

An Alternative Technical Concept (ATC) is a confidential request by a Proposer to modify a contract requirement, specifically for that Proposer, prior to the Proposal due date. The ATC process provides an opportunity for design-build proposals to promote innovation, find the best solutions, and to maintain flexibility in the procurement process. ATC's are evaluated for approval or denial by SCDOT within the deadline set forth in the RFP Milestone Schedule. In order to be approved, an ATC must be deemed, in SCDOT's sole discretion, to provide a project that is "equal or better" on an overall basis than the project would be without the proposed ATC. Concepts that simply delete scope, lower performance requirements, lower standards, conflict with environmental commitments, or reduce contract requirements are not acceptable as ATC's. SCDOT reserves the right in its sole discretion to reject any ATC.

1. Submittal of ATCs:

- a. **Preliminary Concepts:** Preliminary concepts may be submitted that present a description adequate for SCDOT to assess the benefits of the concept. Preliminary concepts may be submitted by email from the Design Build Team Project Manager to the SCDOT Point of Contact and are intended to be an informal inquiry by the Proposer to explore a concept and a quick method by SCDOT to review and comment on potential development of ATC prior to investment of time and resources by the Proposer. Submission of preliminary concepts does not change or extend the submission deadline of formal ATCs. SCDOT reserves the right to ask PROPOSER to clarify its email. If a preliminary concept receives a favorable response from SCDOT, Proposer can elect to submit a formal ATC in accordance with these procedures. A favorable response by SCDOT in no way guarantees that the concept will become an approved ATC. The favorable response may be subject to conditions. **A maximum number of twenty (20) Preliminary Concepts may be submitted to SCDOT by the PROPOSER for consideration.** If more than one Preliminary Concept has been received on the same topic, SCDOT has the right to revise the RFP to include that concept as an addendum to the RFP.
- b. **ATC Identification:** ATC will be submitted by the Proposer and evaluated by SCDOT as set forth in the RFP Milestone Schedule. All ATCs shall be

submitted in writing to the Project Manager identified in the RFP with a cover letter clearly identifying the submittal as a request for review of an ATC under this RFP. If the Proposer does not clearly designate its submittal as an ATC, the submission will not be treated as an ATC by SCDOT.

- c. **A maximum number of seven (7) ATCs may be submitted to SCDOT by the PROPOSER for consideration.**

2. Contents of ATC Submittal:

Each ATC submittal shall include one (1) electronic and one (1) hard-copy and shall include the following:

- a. **Description:** A detailed description and schematic drawings of the configuration of the ATC or other appropriate descriptive information (including, if appropriate, specifications, construction tolerances, special provisions, proposed bridge types, product details, and a traffic operational analysis);
- b. **Usage:** Locations where and an explanation of how the ATC would be used on the Project;
- c. **Deviations:** List in table format, all references to any requirements of the RFP or to any requirements of the Contract Documents that are inconsistent with the proposed ATC. Include an explanation of the nature of the proposed deviation and a request for approval of such deviations or a determination that the ATC is consistent with the requirements of the RFP;
- d. **Justification:** Justify use of the ATC and why the deviations from the requirements of the RFP should be allowed;
- e. **Schedule:** Proposed changes to the project schedule if applicable;
- f. **Impacts:** Identify potential impacts on vehicular traffic, safety, community, utilities, right of way and the environment;
- g. **History:** A detailed description of other projects where the ATC has been used under comparable circumstances, the success of such usage, and names and telephone numbers of project owners that can confirm such statements;
- h. **Risks:** A description of added risks to SCDOT and other persons associated with implementing the ATC;
- i. **Costs:** An estimate of the impact of the ATC on the Proposal Price and the ATC implementation costs to SCDOT, FHWA, CONTRACTOR, or other person during construction, maintenance and operations;

- j. **Quality:** A description of how the ATC is equal or better in quality and performance than the requirements of the RFP;
- k. **Operations & Maintenance:** Any changes in operation or maintenance requirements associated with the ATC,

3. Review of ATCs:

- a. Fourteen Day Review: SCDOT will review each ATC submitted within fourteen (14) calendar days of ATC receipt.
- b. More information Needed: If within seven (7) calendar days of receipt of the ATC SCDOT needs more information to determine whether or not the ATC will be approved or not approved, SCDOT will submit written questions to the PROPOSER and/or request a one-on-one meeting in order to better understand the details of the formal ATC.
 - i. **Questions:** SCDOT may submit written questions to the PROPOSER within seven calendar (7) days of receipt of the ATC. PROPOSER has three (3) calendar days to remit answers. Within four (4) calendar days of receipt of the answers, SCDOT shall respond to the ATC.
 - ii. **One-on-One Meetings:** ATC meeting may be scheduled by SCDOT within seven (7) calendar days of receipt of the ATC. One-on-one meeting(s) may be scheduled to fully understand the details of any formal ATCs. These meetings will be restricted to those persons involved in the review of the ATC and limited to discussions of the PROPOSER'S ATC approach. The purpose of this meeting is to discuss the proposed changes, answer questions, and other relevant issues. Verbal responses are for information only and are not binding. Nothing stated at any ATC meeting(s) will modify the RFP or Contract documents. SCDOT reserves the right to disclose to all PROPOSERS any issues raised during the ATC meeting(s), either in the Final RFP or in an addendum. However, SCDOT will not disclose any information pertaining to an individual PROPOSER'S ATCs or other technical concepts to other Proposers. SCDOT will issue a written response to PROPOSER regarding its ATC.
- c. No Response from SCDOT: If the PROPOSER does not receive correspondence from SCDOT within fourteen (14) calendar days of SCDOT's receipt of the ATC, the ATC is deemed rejected by SCDOT, unless written notification to extend this period is given by SCDOT. No ATC shall be included in the proposal unless approved by SCDOT in writing prior to the proposal submission deadline.
- d. **Conditional Response by SCDOT:** If SCDOT issues a conditional answer; an additional 14 days are added to the Fourteen Day Review

period. 7 days for PROPOSER to respond to the condition, and 7 days for SCDOT to submit its final response to the ATC.

4. Determination of SCDOT

- a. SCDOT will make one of the following written determinations with respect to each properly submitted ATC:
 - i. The ATC is approved, in its entirety or in part;
 - ii. The ATC is not approved;
 - iii. The ATC is not approved in its present form, but may be reconsidered for approval upon satisfaction, in SCDOT's sole discretion, of certain identified conditions that must be met or certain clarifications or modifications that must be made by Proposer. The Proposer shall not have the right to incorporate this ATC into the Proposal unless and until the ATC has been resubmitted within the time limits in the RFP, with the conditions, clarification and modifications satisfied, and SCDOT has unconditionally approved the revised ATC; or
 - iv. The submittal does not qualify as an ATC but appears eligible to be included in the Proposal without an ATC (i.e., the concept appears to conform to the basic configuration and to be consistent with other contract requirements).
 - v. The ATC is deemed to take advantage of an error or omission in the RFP, or other documents incorporated into the contract by reference, the ATC will not be considered, and the RFP will be revised to correct the error or omission
 - vi. More than one formal ATC has been received on the same topic and the Department has elected to exercise its right to issue an addendum to the RFP to include that topic.
- b. Once an ATC has been approved, only the entire ATC is eligible for inclusion into the Proposal. The inclusion of partial ATCs into a Proposal is not allowed, unless the individual ATC's have received separate approval by SCDOT
- c. Each Proposer, by submittal of its Proposal, acknowledges that the opportunity to submit ATCs was offered to all Proposers, and waives any right to object to SCDOT's determinations regarding acceptability of ATCs.

5. Incorporation into Proposal

- a. A Proposer has the option to include any or all approved ATC's in its Proposal. If SCDOT responded to an ATC by identifying conditions for approval, Proposer may not incorporate such ATC into the Proposal unless all conditions have been met. Copies of SCDOT's ATC approval letters for each incorporated ATC shall be included in the Proposal. Proposals

with or without ATCs will be evaluated against the same technical evaluation factors set forth in the EVALUATION OF PROPOSALS section, and the inclusion of an ATC, including an ATC that provides technical enhancements, may or may not receive a higher technical rating. SCDOT approval of an ATC shall not be considered a guaranty that the proposal incorporating the ATC will be selected. SCDOT's rejection of an ATC will not entitle the proposer to an extension of the Proposal submission deadline on the Milestone Schedule or claim for additional costs or delays, including development costs, loss of anticipated profits, or increased material or labor costs.

- b. The Proposal Price should reflect any incorporated approved ATCs.
- c. Except for incorporating approved ATCs, the Proposal may not otherwise contain exceptions to or deviations from the requirements of the RFP.

6. Value Engineering

An approved ATC that is not incorporated into the proposal will not be considered a pre-approved value engineering change.

7. Abandonment of ATC by Proposer

If the approved ATC is abandoned by the Proposer, is unable to obtain required approvals, is otherwise proved to be infeasible, or fails to be constructed for any reason, the successful Proposer is obligated and required to complete the project utilizing the original RFP design and scope requirements at the awarded cost, and shall be responsible for any redesign costs.

8. SCDOT's use of Concepts Contained in an ATC

SCDOT expressly reserves the right to adopt and use any ATC, approved or disapproved, by the successful Proposer on this contract or other contracts administered by SCDOT. By submitting a Proposal, all unsuccessful PROPOSERS acknowledge that upon acceptance of the designated stipend, all approved or disapproved ATC's may be included in this contract or other contracts administered by SCDOT and shall become the property of SCDOT without restriction on use. Prior to contract execution, limited negotiations may be conducted as necessary to incorporate the ideas and concepts from unsuccessful PROPOSERS provided a stipend is accepted by the unsuccessful offerer.

9. Proposer Obligations.

The successful Proposer, in addition to performing all other requirements of the Contract Documents, shall:

- a. Obtain and pay the cost of obtaining all required approvals including approvals required to implement any approved ATC(s) incorporated into the Contract Documents;

- b. Obtain and pay the cost of obtaining any third party approvals required to implement any approved ATC(s) incorporated into the Contract Documents; and
- c. Unless otherwise noted in the Contract, be responsible for all costs and/or delays of any nature associated with the implementation of any approved ATC incorporated into the Contract Documents.
- d. Should SCDOT revise the RFP after a formal ATC has been approved, be solely responsible for reviewing the RFP and determining if the ATC deviates from the revised requirements. If required, the Proposer must submit a request for approval of all additional variances required within seven (7) calendar days of receipt of the revised RFP.

Stipends

By submitting a Proposal in response to the RFP, the PROPOSER acknowledges the following:

- A. It is the intent of SCDOT to award a stipend of \$60,000.00 to each responsible and responsive PROPOSER subject to the terms of the Stipend Agreement set forth in ARTICLE XIII of the RFP.
- B. PROPOSERS shall indicate on the Stipend Acknowledgement Form in Section XII to the RFP whether it elects to receive a stipend. The Stipend Acknowledgement Form shall be signed and returned with the unsealed Technical Proposal. The Stipend Acknowledgment Form will not count against the specified page limit.
- C. If PROPOSER elects to receive a stipend, the Stipend Agreement shall be signed by PROPOSER and submitted as part of the unsealed Technical proposal. The Stipend Agreement will not count against the specified page limit.

Proposal Submittal

Proposals must be received by the time and date given in the Milestone Schedule. Deliver TEN (10) printed and bound copies and one (1) electronic PDF (CD) copy of the Technical Proposal and one (1) sealed, printed copy of the Cost Proposal to:

Contract Administrator
South Carolina Department of Transportation
955 Park Street, Room 333
Post Office Box 191
Columbia, South Carolina 29202-0191

IV. PROJECT SCOPE

See Exhibit 3.

V. PROPOSAL DEVELOPMENT

Proposals must be submitted concurrently in two parts, a Technical Proposal and a Cost Proposal. The Technical Proposal shall contain no more than twenty (20) pages, excluding any plans and appendices. The Technical Proposal shall be single sided, with minimum twelve-point (12) font and double line spacing for text. The Cost Proposal shall be bound and sealed separately from the Technical Proposal. The Cost Proposal shall be clearly marked as “Confidential Proprietary Information” by the PROPOSER and shall include the completed Cost Proposal Bid Form. Responses should address all of the items listed below. If a PROPOSER does not, at a minimum, submit responses to these items, the submittal may be considered non-responsive and returned without further review/evaluation. In order to meet the minimum requirements of this RFP, PROPOSER must provide responses to each of the items listed. **Beyond the minimum requirements**, a maximum of 20 quality credit points are available to the PROPOSER based on the commitments to the bolded items below. **Responses must be in the form of commitments in order to receive quality credit.** Conceptual plans that conflict with RFP requirements, and are not submitted under the ATC process, may result in the proposal being deemed non-responsive. Any concepts that conflict with the RFP specifications discovered after award of the project, and which are not approved as an ATC, shall not prevail over RFP specifications. Point values for each of the bolded items are shown at the end of each item.

PROPOSERS are advised that SCDOT reserves the right to conduct an independent investigation of any information, including prior experience, identified in the responses. PROPOSERS are responsible for affecting delivery by the deadline date. Late submissions will be rejected without opening. SCDOT accepts no responsibility for misdirected or lost proposals.

Technical Proposal

In order that evaluation may be accomplished efficiently, the Technical Proposal shall be prepared in the following sequence:

The Proposal shall include:

1. Conceptual Bridge Plans which shall consist of:
 - a. Title Sheet
 - b. Plan and Profile of the bridge showing the proposed type of superstructure and substructures and existing ground profiles at the bridge site
 - c. Superstructure cross section showing pertinent structural elements
 - d. Bridge rails, and sidewalks
 - e. Horizontal and vertical clearances.
 - f. Fender system details.

2. Conceptual Roadway Plans which shall consist of:

- a. Plan and Profile of roadway approaches
- b. Plan and Profile for the SC 41 relocation and new intersection with S-08-33.
- c. Typical sections for all roadways
- d. Details on designed fills, permanent retaining walls, and temporary shoring
- e. Proposed R/W limits

PROPOSERS must provide responses to the items below in order to provide SCDOT a general overview of the PROPOSER'S approach to the project. The 20 quality credit points will be based on the commitments in the responses to the items below:

3. **Identify commitments of materials, designs, and construction methods that would minimize maintenance costs in the future to the Department and benefit the project. (6 points)**
4. **Describe the approach and team commitment in design, construction, and agency coordination to minimize impacts to the environmental resources. Quantify and describe all environmental impacts associated with the approach and project delivery. (2 points)**
5. **Describe and quantify the team's commitment to minimizing utility impacts including any special utility design considerations. (2 points)**
6. **Describe any proposed warranties that are above and beyond what is required for this project, and additional Project risks assumed by the PROPOSER beyond those assigned in this RFP and Agreement. (3 points)**
7. **Describe any additional enhancements that will be included in the Project. (3 points)**
8. **Describe the team's approach to minimizing the SCDOT's risk for maintenance of the swing-span during construction beyond the requirements in Exhibit 3. Include the team's approach for minimizing the opening of the swing-span, for construction related reasons. (4 points)**

Note: Drawings and plans requested as part of the Technical Proposal shall not count against the page limit and can be included in the Appendix.

Cost Proposal

PROPOSERS shall complete the Cost Proposal Bid Form provided at the end of this document. The Cost Proposal Bid Form along with the DBE committal sheet shall be sealed in a separate envelope and delivered as part of the proposal.

Confidentiality of Proposals

PROPOSER shall specifically mark any elements that are deemed confidential, or proprietary. All markings must be conspicuous; use color, bold, underlining, or some other method in order to conspicuously distinguish the mark from the other text. Do not mark the entire proposal as confidential or proprietary. In determining whether to release documents, the SCDOT will rely on PROPOSER's marking of each page or portions of pages of documents, as required by these instructions, as being either "Confidential" or "Trade Secret". PROPOSER shall be prepared upon request to provide justification of why such materials shall not be disclosed under the South Carolina Freedom of Information Act, Section 30-4-10, et seq., South Carolina Code of Laws (1976) as amended. Proposals will be kept confidential and will not be disclosed, except as may be required by law.

Noncollusion and Equal Employment Opportunity Certification

PROPOSERS shall certify that they have not participated in any collusion or otherwise taken any action in restraint of free competitive bidding in connection with the submission of this proposal on this project. Proposal submitted without the non-collusion certification may be deemed non-responsive. The non-collusion certification form provided as part of this document shall be submitted as part of the Technical proposal and will not count against the specified page limit.

PROPOSERS shall complete the Equal Protection Opportunity (EEO) Performance Certification form provided as part of this document. Proposal submitted without the EEO certification may be deemed non-responsive. The EEO certification form shall be submitted as part of the Technical proposal and will not count against the specified page limit.

VI. EVALUATION OF PROPOSALS

Proposal Review Committee

A Proposal Review Committee ("Committee") will be appointed by SCDOT to review the Proposals. The voting members will be comprised of SCDOT employees. In addition, SCDOT will assemble a group of non-voting resource members having expertise in the various disciplines required by the project including the Federal Highway Administration.

Proposal Review

The Committee will review the Proposals and determine whether each Proposal is responsive. Responsive Proposals will be accepted by the Committee for evaluation. Any non-responsive

Proposal will be returned to the PROPOSER with a detailed explanation as to reasons for determining non-responsiveness. Reasons for determining a proposal to be non-responsive may result from, but are not limited to, the following: failure to provide all information requested in the proposal, failure to conform to the material requirements of the RFP, failure to meet the contract goal or make good faith efforts to meet the contract goal, conflict of interests, conditional proposals, failure to provide complete and honest information, failure to complete the Cost Proposal Bid Form correctly, failure to submit the EEO certification, and failure to provide a DBE committal sheet in the Cost Proposal Packet. Responsive Proposals will be evaluated and scored by the Committee. Proposals which impose conditions that modify material requirements of the RFP may be rejected as non-responsive. Proposers will not be given an opportunity to correct any material nonconformity. Any deficiency resulting from a minor informality may be clarified or waived at the sole discretion of the SCDOT.

Technical Evaluation

All Proposals will be evaluated for technical merit prior to opening the cost proposals. The committee will determine responsiveness of the technical proposal based on responses to all items requested. For the items that have quality credit points associated with them, the Committee will utilize the table below entitled “Quality Credit Percentage for Technical Proposals” to assign a Quality Credit Percentage to each Proposal based on the Proposer’s overall quality score. The maximum quality credit percentage for this project will be 4%.

Quality Credit Percentage for Technical Proposals

Quality Points	Quality Credit (%)
20	4.0
19	3.8
18	3.6
17	3.4
16	3.2
15	3.0
14	2.8
13	2.6
12	2.4
11	2.2
10	2.0
9	1.8
8	1.6
7	1.4
6	1.2
5	1.0
4	0.8
3	0.6
2	0.4
1	0.2

Presentations

PROPOSERS who have submitted responsive Technical Proposals may be invited by the Committee to make a presentation. The presentation, if required, will allow the Proposers an opportunity to further explain any aspect of their Technical Proposals. The Committee may address questions to the Proposer after the presentation.

Clarifications

SCDOT, at its sole discretion, shall have the right to seek clarifications from any PROPOSER to fully understand information contained in their responses to the RFP. Clarifications mean a written or oral exchange of information which takes place after the receipt of proposals when award without discussions is contemplated. The purpose of clarifications is to address minor or clerical revisions in a proposal.

Opening of Cost Proposals

All Technical Proposals will be evaluated for responsiveness based on those items requested in this RFP. Those Technical Proposals deemed non-responsive for any reason will be returned to the PROPOSER along with the PROPOSER's unopened Cost Proposal prior to the Opening of Cost Proposals. Those Technical Proposals deemed responsive will be scored according to the information provided in this RFP. Based upon that score, a Quality Credit percentage will be applied to the PROPOSER's Cost Proposal, in accordance with the table shown above. The Quality Credit percentage will be provided confidentially in a sealed envelope to each PROPOSER at the Opening of Cost Proposals meeting as shown on the Project Milestones – Section IX of this RFP.

Cost Proposals of PROPOSERS with responsive Technical Proposals will be opened at the meeting. The Total Bid amount shown on the Cost Proposal Bid Form and the Quality Credit Score for each respective PROPOSER will be entered into a spreadsheet and analyzed. Each Cost Proposal will be compared against the confidential SCDOT Engineer's Estimate.

If upon analysis, one or more of the Total Adjusted Bids is within an acceptable range of the Engineer's Estimate, all Total Bid Amounts (including A and B portions if applicable) and Quality Credit Scores for each PROPOSER will be read aloud and the proposals will be ranked based on the lowest Total Adjusted Bid.

If upon analysis, all of the Total Adjusted Bids exceed an acceptable range of the Engineer's Estimate, only the Total Bid Amounts (including the A and B portions if applicable) will be read and the Quality Credit Scores for each PROPOSER will remain confidential and be known only to each respective PROPOSER. The meeting will then adjourn so that SCDOT personnel may assess if either award outside the prescribed range is justified or if the SCDOT will hold discussions and may request a Best and Final Offer (BAFO) from all responsive PROPOSERS.

In the event that SCDOT elects NOT to proceed with a Best and Final Offer (BAFO), then SCDOT will schedule a date and time to publicly reiterate all Total Bids Amounts and read all Technical Scores.

SCDOT intends to award the contract to the PROPOSER with the lowest Total Adjusted Bid. However, the RFP may be cancelled after opening, but prior to the issuance of an award, when such action is determined in writing to clearly be in the best interest of the State. If the RFP is cancelled, proposals shall be returned to the PROPOSERS and a new solicitation must be conducted for the project.

Total Adjusted Bid Determination

The adjusted low bid method will be utilized in determining the lowest Total Adjusted Bid. Award of the Contract, if made, will be made to the responsible and qualified Proposer who submits the lowest Total Adjusted Bid. In the event that two or more Proposers are determined to have the same lowest total adjusted bid, the award, if made, will be made to the Proposer with the highest quality credit score. The following formula will be used to evaluate the values given on the Cost Proposal Bid Form:

Total Adjusted Bid = A - [A x Quality Credit]:

A is the Guaranteed Maximum Cost to Complete all work to be performed under the contract

Quality Credit is the assigned quality credit percentage as a result of the proposal's technical score; expressed as a decimal.

Example for Determining Total Adjusted Bid

Proposal	Quality Points	Quality Credit (%)	Cost Proposal (A)	Quality Value	Total Adjusted Bid
A	20	4.0	29,500,000	1,180,000	28,320,000
B	15	3.0	29,000,000	870,000	28,130,000
C	10	2.0	28,500,000	570,000	27,930,000
D	0	0.0	28,000,000	0	28,000,000

Note: In this example, Proposal C was determined to be the lowest total adjusted bid

VII. SELECTION OF CONTRACTOR

The Committee will present a report regarding their review of the proposals to SCDOT Deputy Secretary for Engineering and recommend selection of the PROPOSER with the lowest Total Adjusted Bid. Upon approval, SCDOT will offer a contract to the selected PROPOSER. *However, if the parties are unable to execute a contract, SCDOT may offer a contract to the PROPOSER with the next lowest Total Adjusted Bid.*

The Design-Build Agreement will be executed for the Guaranteed Maximum Cost to Complete as shown in the cost envelope and the maximum Contract Time will be the Guaranteed Maximum Number of Calendar Days from full Notice to Proceed to Substantial Work Completion of the Project. Contract time for the Project shall be established as shown on the Cost Proposal Bid Form.

VIII. GENERAL INFORMATION

1. SCDOT reserves the right to terminate evaluation of one or more of the proposals if it is determined to be in the best interest of the state to do so.
2. SCDOT reserves the right, at its sole discretion, to either cancel this solicitation or to re-advertise in another public solicitation when it is in the best interest of the state to do so.
3. SCDOT reserves the right to reject any and all proposals, or parts thereof, and/or to discontinue contract execution with any party at any time prior to final contract execution.
4. SCDOT assumes no liability and will not reimburse costs incurred by firms, whether selected or not, in developing proposals or in contract execution.
5. SCDOT reserves the right to request or obtain additional information about any and all proposals. SCDOT may also issue addenda to the RFP, which will be mailed to all RFP holders.
6. SCDOT reserves the right to revise or amend the RFP, specifications and/or drawings, including changes to the date the proposal is due. Such changes, if any, will be announced by an addendum or addendums to this Request for Proposal. All information relating to this RFP, including pertinent changes/addendums and other applicable information will be posted on SCDOT's design build website www.SCDOT.org a minimum of ten (10) business days prior to the date set for receipt of proposals as set forth in the Milestone Schedule. If changes are made to the RFP within ten (10) days of the due date, Milestones may be adjusted accordingly. **PROPOSERS are strongly cautioned to check this site frequently to ensure they have the latest information.**
7. Receipt of an addendum by the PROPOSER must be acknowledged in the space provided on the Addendum Notice to Proposer Transmittal Form posted on the SCDOT Design Build website for this project. PROPOSERS shall submit the signed Notice with its response to this RFP. Failure to acknowledge an addendum may result in rejection of the proposal. Explanations or instructions given in a form other than an addendum or ATC response letter shall not be binding.

8. After award, if an unsuccessful PROPOSER would like to schedule a debriefing, PROPOSER shall submit a request within three (3) working days from the date the award notification is posted on the SCDOT Design Build website for this Project. Only written requests (emails are acceptable) for a debriefing will be scheduled. Failure to request a debriefing within the three (3) day period waives the opportunity for a debriefing.
9. All PROPOSERS must visibly mark as “CONFIDENTIAL” each part of their submission that they consider to contain proprietary information the release of which would constitute an unreasonable invasion of privacy. All unmarked pages will be subject to release in accordance with law. PROPOSER should be prepared, upon request, to provide justification of why such materials should not be disclosed under the South Carolina Freedom of Information Act, S.C. Code Section 30-4-10, et seq.
10. PROPOSER shall be held responsible for the validity of all information supplied in its proposal, including that provided by potential subcontractors. Should subsequent investigation disclose that the facts and conditions were not as stated, the proposal may be rejected or contract terminated for default if after award, in addition to any other remedy available under the contract or by law.
11. PROPOSER, by submitting a proposal, represents that it has read and understands the RFP, its exhibits, attachments and addendums, and that its proposal is made in compliance with the criteria of the RFP. PROPOSERS are expected to examine the RFP, its exhibits, attachments and addendums thoroughly and should request an explanation of any ambiguities, discrepancies, errors, omissions, or conflicting statements therein. Failure to do so will be at the Proposer's risk. Proposer assumes responsibility for any patent ambiguity in the RFP, its exhibits, attachments and addendums that Proposer does not bring to SCDOT's attention.
12. No proposal guaranty in the form of a Bid Bond is required for this procurement.

IX. MILESTONES

Provide RFP for Industry Review to Selected Short-list PROPOSERS	Wednesday, August 07, 2013
Deadline Clarifications/Comments to be submitted by PROPOSERS	Wednesday, August 21, 2013
Issue Final RFP	Friday, September 27, 2013
Preliminary ATC Concept Submittals (Start)	Friday, September 27, 2013
Confidential RFP and ATC Questions to be submitted by PROPOSERS	Wednesday, October 16, 2013
Confidential RFP and ATC One-on-One meetings with PROPOSERS	Thursday, October 24, 2013
Begin Formal ATC Process	Thursday, October 24, 2013
All ATC's SHALL be submitted prior to	Wednesday, November 13, 2013
Submittal of Proposals	Wednesday, December 18, 2013 , by 2:00 PM EDT.
Bid Opening(with team representatives present)	Friday, January 10, 2014
Award/Contract Execution	February 2014

X. COST PROPOSAL BID FORM

SC Route 41 Bridge Replacement Over the Wando River Berkeley and Charleston Counties

CONTRACTOR: _____

ADDRESS: _____

Provide full project scope as described in Attachment A.

GUARANTEED MAXIMUM COST TO COMPLETE (A)= _____

TIME FOR COMPLETION OF PROJECT IS DEFINED AS 1277 CALENDAR DAYS FROM FULL NOTICE TO PROCEED FOR PROJECT TO SUBSTANTIAL WORK COMPLETION OF THE PROJECT. FULL NOTICE TO PROCEED SHALL BE NO LATER THAN 45 DAYS FROM THE EFFECTIVE DATE OF THE AGREEMENT.

No conditional Bids will be accepted. SCDOT reserves the right to delete any or all conditions placed on the Guaranteed Maximum Cost to Complete, and/or reserves the right to reject any Bid that is conditional or contains additions not called for in the plans and specifications.

Signature

Date

Printed Name

XI. NON-COLLUSION AND EEO CERTIFICATIONS

NON-COLLUSION CERTIFICATION

Federal Project: BR88(079)

State Project: 8.158B, 10.032100

IN ACCORDANCE WITH THE PROVISIONS OF S.C. CODE ANN. §§ 39-3-10 ET.SEQ., 39-5-10 ET. SEQ., 15 U.S.C. §45; 23 C.F.R. §635.112(F); AND 28 U.S.C. §1746, I HEREBY ACKNOWLEDGE THAT I AM AN OFFICER OF THE PROPOSER FIRM AND, UNDER PENALTY OF PERJURY UNDER THE LAWS OF THE UNITED STATES AND SOUTH CAROLINA, DECLARE, BY MY CERTIFICATION BELOW, THAT THE FOLLOWING IS TRUE AND CORRECT, AND FURTHER, THAT THIS FIRM, ASSOCIATION OR CORPORATION HAS NOT, EITHER DIRECTLY OR INDIRECTLY, ENTERED INTO ANY AGREEMENT, PARTICIPATED IN ANY COLLUSION, OR OTHERWISE TAKEN ANY ACTION IN RESTRAINT OF FREE COMPETITIVE BIDDING IN CONNECTION WITH THE SUBMISSION OF A BID PROPOSAL ON THE ABOVE REFERENCED PROJECT.

BY CHECKING THIS BOX , I CERTIFY THAT I HAVE READ, UNDERSTAND, ACCEPT, AND ACKNOWLEDGE ALL OF THE ABOVE STATEMENTS.

Executed on _____, 2011.

Signed: _____

(Officer/Proposer)

(Title)

(Address)

(COMPLETE THIS SECTION FOR FEDERAL PROJECTS ONLY)

EQUAL EMPLOYMENT OPPORTUNITY PERFORMANCE

Select the Certification that applies to the PROPOSER:

Certification (1) **or** **Certification (2)**

Select the appropriate responses in the applicable Certification:

Certification (1): Pursuant to 41 C.F.R. §60-1.7(b)(1), Previous Equal Employment Opportunity Performance Certification, as the Prospective Prime Contractor, **I HEREBY CERTIFY THAT I:**

- (a) **(HAVE / HAVE NOT)** developed and filed an Affirmative Action Program pursuant to 41 C.F.R. §60-2;
- (b) **(HAVE / HAVE NOT)** participated in a previous contract or subcontract subject to the equal opportunity clause;
- (c) **(HAVE / HAVE NOT)** filed with the Joint Reporting Committee, the Director of Office of Federal Contract Compliance, or the Equal Employment Opportunity Commission, all reports due under the applicable filing requirements,

OR

Certification (2): **I, HEREBY CERTIFY** that as the Prospective Prime Contractor submitting this Proposal, **(CLAIM / DO NOT CLAIM)** exemption from the submission of the Standard Form 100 (EEO-1) due to the fact that it employs a total of less than fifty (50) employees under C.F.R. §60-1.7, or qualifies for an exempted status under 41 C.F.R. §60-1.5.

I FURTHER CERTIFY that the above Certification will be made part of any Subcontract Agreement involved with this project.

Executed on _____, 20____. Signed: _____

(Officer/Proposer)

(Title)

(Company)

(Address)

SEAL

XII. STIPEND ACKNOWLEDGEMENT FORM

Stipend Acknowledgement Form SC Route 41 Bridge Replacement Over the Wando River Berkeley and Charleston Counties

PROPOSER: _____

ADDRESS: _____

The undersigned PROPOSER, hereby:

Waives the stipend for this Project.

Accepts the stipend for this Project.

By accepting the stipend for this Project, PROPOSER agrees:

- 1) to execute and include the Stipend Agreement in Article XIII of the RFP with their RFP response;
- 2) SCDOT will pay the stipend to each eligible unsuccessful PROPOSER, who has signed a Stipend Agreement, within ninety (90) days after execution of the contract or the decision not to award a contract;
- 3) to transfer all rights to its Work Product used to develop the proposal as of the date of this acknowledgement. "Work Product" means all submittals, including ATCs, ideas, innovations, solutions, methods, processes, design concepts, materials, electronic files, marked up drawings, cross sections, quantity lists and intellectual property, made by proposer during the RFP process, including the proposal, exchange of information during the pre-proposal and post-proposal period.

Date

PROPOSER

Print Name

XIII. STIPEND AGREEMENT

STIPEND AGREEMENT

File No.: 8.158B, 10.032100

Project Description: SC Route 41 Bridge Replacement Over the Wando River
Berkeley and Charleston Counties

THIS STIPEND AGREEMENT (the "Agreement") is made and entered into as of the ___ day of _____, 20__, by and between the SOUTH CAROLINA DEPARTMENT OF TRANSPORTATION (hereinafter "SCDOT"), and _____ ("PROPOSER"), with reference to the following facts:

SCDOT issued a Request for Proposal ("RFP") for design and construction of the above-referenced Design-Build Project ("Project"), pursuant to procurement authority granted in Section 57-5-1625 of the S.C. Code of Laws, 1976, as amended. The RFP provided for payment of stipends as provided herein.

NOW, THEREFORE, PROPOSER hereby agrees as follows:

1. Work Product.

1.1 PROPOSER shall prepare and submit a responsible and responsive technical and cost proposal that conforms in all material respects to the requirements and provisions of the RFP, as determined by SCDOT, and are timely received by SCDOT in accordance with the RFP Milestone Schedule.

1.2 By signing this Stipend Agreement, PROPOSER agrees to transfer ownership to SCDOT of the electronic copy and hard copy of all Work Product used to develop the proposal. The Work Product (as defined below) shall become the property of SCDOT without restriction or limitation on its use, without further compensation or consideration, and can be used in connection with this Project or any future projects by SCDOT. Neither PROPOSER nor any of its team members shall copyright any of the material developed under this Agreement.

1.3 The term "Work Product" shall mean all material, electronic files, marked up drawings, cross sections, quantity lists, submittals, alternative technical concepts (ATC), ideas, innovations, solutions, methods, processes, design concepts, and intellectual property, made by or produced for PROPOSER in the development and submission of the technical and price proposals, including exchanges of information during the pre-proposal and post-proposal period.

2. Compensation and Payment.

2.1 A stipend to PROPOSER for the Work Product described herein shall be ~~\$60,000.00~~ and is payable on condition that PROPOSER (1) submitted a responsible and responsive technical and cost proposal to the RFP which is not selected for award of this Project, or (2) was awarded the Contract but the Contract was terminated by SCDOT at SCDOT's convenience after the Submittal of Proposal Date (See Final RFP Milestone schedule) but prior to the Notice to Proceed. Responsibility and responsiveness of the proposal will be determined by SCDOT as a condition of payment.

2.2 SCDOT will pay the stipend to PROPOSER under the following conditions:

(a) Within ninety (90) days after execution of the contract or the decision not to award a contract, SCDOT will pay the stipend to the unsuccessful PROPOSER meeting the criteria of Section 2.1, provided that the PROPOSER submitted a signed a Stipend Agreement with its response to the RFP.

(b) If the procurement is suspended or cancelled prior to the Proposal Due Date (see FINAL RFP Milestone schedule), no stipend will be paid to PROPOSER.

(c) After the submittal of proposals, but prior to award, if the procurement is cancelled, all PROPOSERS that provide a responsive technical and cost proposal to the final RFP and submitted a signed Stipend Agreement with their RFP shall receive the stipend

(d) In the event of a Best and Final Offer, only one stipend will be paid.

(e) No stipends will be paid for submitting RFQ responses.

2.3 Acceptance by the PROPOSER of payment of the stipend amount from SCDOT shall constitute a waiver by PROPOSER of any and all right, equitable or otherwise, to bring any claim in connection with this procurement, procurement process, award of the Contract, or cancellation of this procurement.

2.4 The PROPOSER awarded the contract shall be not eligible to receive a stipend.

2.5 If PROPOSER elects to waive payment of the stipend, SCDOT will not use the ideas or information contained in that PROPOSER's proposal for this Project. However, the PROPOSER's proposal will be subject to the South Carolina Freedom of Information Act.

REQUEST FOR PROPOSALS

SC Route 41 Bridge Replacement Over the Wando River
File Nos. 8.158B & 10.032100, Federal Aid Project No. BR88(079)
Berkeley and Charleston Counties, South Carolina

3. Indemnities.

3.1 Subject to the limitations contained in Section 3.2, PROPOSER shall indemnify, protect and hold harmless SCDOT and its directors, officers, employees and contractors from, and PROPOSER shall defend at its own expense, all claims, costs, expenses, liabilities, demands, or suits at law or equity arising in whole or in part from the negligence or willful misconduct of PROPOSER or any of its agents, officers, employees, representatives or subcontractors or breach of any of PROPOSER’s obligations under this Agreement.

3.2 This indemnity shall not apply with respect to any claims, demands or suits arising from use of the Work Product by SCDOT.

4. Compliance With Laws.

4.1 PROPOSER shall comply with all federal, state, and local laws, ordinances, rules, and regulations applicable to the work performed or paid for under this Agreement and covenants and agrees that it and its employees shall be bound by the standards of conduct provided in applicable laws, ordinances, rules, and regulations as they relate to work performed under this Agreement. PROPOSER agrees to incorporate the provisions of this paragraph in any subcontract into which it might enter with reference to the work performed pursuant to this Agreement.

4.2 The PROPOSER agrees (a) not to discriminate in any manner against an employee or applicant for employment because of race, color, religion, creed, age, sex, marital status, national origin, ancestry or disability of a qualified individual with a disability; (b) to include a provision similar to that contained in subsection (a) in any subcontract; and (c) to post and to cause subcontractors to post in conspicuous places available to employees and applicants for employment, notices setting forth the substance of this clause.

5. Assignment.

PROPOSER shall not assign this Agreement without SCDOT’s prior written consent. Any assignment of this Agreement without such consent shall be null and void.

6. Miscellaneous.

6.1 PROPOSER and SCDOT agree that PROPOSER, its team members, and their respective employees are not agents of SCDOT as a result of this Agreement.

6.2 This Agreement, together with the RFP, as amended from time to time, the provisions of which are incorporated herein by reference, embodies the entire agreement of the parties. There are no promises, terms, conditions, or obligations other than those contained herein or in the RFP, and this Agreement shall supersede all previous communications, representation, or agreements, either verbal or written, between the parties hereto.

6.3 It is understood and agreed by the parties hereto that if any part, term, or provision of this Agreement is by the courts held to be illegal or in conflict with any law of the State of South Carolina, the validity of the remaining portions or provisions shall not be affected, and the rights and obligations of the parties shall be construed and enforced as if the Agreement did not contain the particular part, term, or provisions to be invalid.

6.4 This Agreement shall be governed by and construed in accordance with the laws of the State of South Carolina.

IN WITNESS WHEREOF, the parties have executed this Agreement as of the date first written above.

Witness:

SOUTH CAROLINA DEPARTMENT
OF TRANSPORTATION

By: _____
Matthew R. Lifsey, P.E.
Regional Production Engineer

Recommended:

Jae Mattox, P.E.
Program Manager

PROPOSER

Name of PROPOSER

Witness:

By: _____
Its: _____

AGREEMENT

**AGREEMENT
FOR THE DESIGN & CONSTRUCTION
OF
SC Route 41 Bridge Replacement
Over the Wando River**

Berkeley and Charleston Counties

A DESIGN-BUILD PROJECT

**BETWEEN
SOUTH CAROLINA DEPARTMENT OF TRANSPORTATION
AND**

_____ day of _____, 2013

SC File No. 8.158B & 10.032100
Federal Aid Project No. BR88(079)

Agreement for SC Route 41 Bridge Replacement over the Wando River
Berkeley and Charleston Counties

TABLE OF CONTENTS	Page Number
LIST OF EXHIBITS.....	4
I. CONTRACT DOCUMENTS	6
II. PROJECT SCOPE	6
A. Scope of Work	6
B. Design and Construction Responsibilities	6
C. Design Criteria	7
D. Design Review	7
E. Maintenance of Traffic	8
F. Ownership of Documents	8
G. Construction Criteria.....	9
H. Project Management	9
I. Control of the Work	10
J. Contract Deliverables.....	10
III. CONTRACT PRICE/CONTRACT PAYMENTS	11
A. Contract Price.....	11
B. Contract Price Adjustments	11
C. Contract Payments	13
D. Retainage.....	16
IV. CONTRACT TIME	16
A. Project Schedule.....	16
B. Contract Time Adjustments	18
C. Owner’s Right to Stop Work	19
D. Liquidated Damages	19
V. QUALITY ASSURANCE PROGRAM	19
A. CONTRACTOR’s Responsibilities	19
B. SCDOT Responsibilities.....	21
C. CONTRACTOR’s Obligation	22
VI. INSURANCE AND BONDING.....	22
A. Insurance	22
B. Bonding.....	25
VII. UTILITIES and railroad coordination	25
VIII. RIGHT OF WAY ACQUISITION.....	28

Agreement for SC Route 41 Bridge Replacement over the Wando River
Berkeley and Charleston Counties

A.	Right of Way Services	28
B.	Acquisition of Right-of-Way	31
IX.	PERMITS.....	33
X.	ENVIRONMENTAL COMPLIANCE.....	33
A.	Compliance with Environmental Commitments.....	33
B.	Preconstruction / Partnering Conference(s).....	34
C.	Protection of Archeological and Paleontological Remains and Materials.....	34
XI.	HAZARDOUS MATERIALS	35
XII.	DEMOLITION, REMOVAL & DISPOSAL OF STRUCTURES.....	36
XIII.	DIFFERING SITE CONDITIONS.....	36
XIV.	FORCE MAJEURE	37
XV.	WARRANTY	37
XVI.	INDEMNITY	38
XVII.	TERMINATION AND CANCELLATION	38
XVIII.	DISADVANTAGED BUSINESS ENTERPRISES	40
XIX.	ON-THE-JOB TRAINING REQUIREMENTS	41
XX.	RECORD RETENTION.....	41
XXI.	AS-BUILTS	42
XXII.	ESCROW PROPOSAL DOCUMENTS.....	43
A.	Scope and Purpose	43
B.	Proposal Documentation.....	43
C.	Submittal of Proposal Documentation	43
D.	Alternative Delivery Method	43
E.	Affidavit.....	44
F.	Verification	44
G.	Duration and Use	44
H.	Refusal or Failure to Provide Proposal Documentation	44
I.	Confidentiality of Bid Documentation.....	45
J.	Cost and Escrow Instructions.....	45
K.	Escrow Agreement.....	45
L.	Payment.....	45
XXIII.	DISPUTE RESOLUTION	45

XXIV.	SCDOT'S AGENT	46
XXV.	ASSIGNABILITY	46
XXVI.	GENERAL PROVISIONS	46
	CERTIFICATION OF CONTRACTOR	49
	CERTIFICATION OF DEPARTMENT	50

LIST OF EXHIBITS

1. Cost Proposal Bid Form
2. Schedule of Values
3. Scope of Work
4. Project Design Criteria
 - 4a. Roadway
 - 4b. Structures
 - 4c. Pavement
 - 4d. Traffic
 - Part 1 – Signing and Pavement Marking
 - Part 2 – Work Zone Traffic Control
 - Part 3 – Traffic Signals
 - 4e. Drainage
 - 4f. Geotechnical
5. Special Provisions
6. Supplemental Specifications and Forms
7. Federal Aid Project Supplemental Specifications
8. Environmental Information
9. Escrow Proposal Documents

WHEREAS, the South Carolina Department of Transportation, as an agency of the State of South Carolina, wishes to improve the safety of the state highway system by replacing the SC Route 41 Bridge over the Wando River in Berkeley and Charleston Counties (hereinafter referred to as “the Project”); and

WHEREAS, the South Carolina Department of Transportation, as a servant of the people of the State of South Carolina, wishes to see this strategic project completed; and

WHEREAS, limitations imposed by traditional methods of designing, and constructing highways would mean that the Project could be completed only after an unacceptable delay; and

WHEREAS, the South Carolina Department of Transportation, working with the Federal Highway Administration (FHWA), has devised an innovative plan to allow the commencement and completion of the Project in a timely and cost-effective manner; and

WHEREAS, pursuant to Section 57-5-1625 SC Code of Law, the South Carolina Department of Transportation desires to award a highway construction contract using a Design / Build procedure; and

WHEREAS, after a competitive process, CONTRACTOR has been selected to participate in this venture by designing and building the Project; and

WHEREAS, the South Carolina Department of Transportation wishes to avail itself of and rely on CONTRACTOR’s expertise and proven track record in designing and constructing such projects, on time and within budget; and

WHEREAS, CONTRACTOR wishes to provide that expertise and to participate in this venture for the good of the people of the State of South Carolina;

NOW THEREFORE, this Agreement is executed and made, effective as of the Effective Date as defined herein, between the SOUTH CAROLINA DEPARTMENT OF TRANSPORTATION (“SCDOT”) and _____ (“CONTRACTOR”). In consideration of the covenants hereinafter set forth, the parties hereto mutually agree as follows:

I. CONTRACT DOCUMENTS

The Contract shall be composed of this Agreement and all exhibits, SCDOT's Request for Proposals and all attachments, Request for Qualifications and all attachments, CONTRACTOR's Proposal and all attachments, and CONTRACTOR'S Qualifications and all attachments. In case of conflict, the order of precedence of the Contract documents shall be: (1) this Agreement; (2) Agreement Exhibits; (3) SCDOT Request for Proposals (RFP) document and Project Information; (4) CONTRACTOR's Proposal and attachments; and (5) SCDOT Request for Qualifications (RFQ) and CONTRACTOR's response. In the event of a conflict between the Project Criteria, Special Provisions and Supplemental Specifications identified in the Agreement Exhibits, the order of precedence shall be (1) the Project Criteria; (2) Special Provisions, and (3) Supplemental Specifications and Forms.

II. PROJECT SCOPE

A. Scope of Work

CONTRACTOR shall furnish all services, labor, materials, equipment, supplies, tools, transportation, and coordination required to perform all design, preliminary engineering, surveying, geotechnical services, scheduling, permitting, right of way services, procurement, construction, utility coordination, demolition, material disposal and any other services necessary to perform the Project as defined in the Project Scope of Work made a part hereof as **EXHIBIT 3**.

B. Design and Construction Responsibilities

1. CONTRACTOR, consistent with applicable state licensing laws, shall provide, through qualified South Carolina licensed design professionals employed by CONTRACTOR or procured from qualified, independent South Carolina licensed design consultants, the necessary design work, including, but not limited to, surveys, right of way services, roadway design, maintenance of traffic, geotechnical exploration and design, hydraulic analyses, storm water management, erosion control, superstructure design, and foundation and substructure design including seismic analyses for the preparation of the required drawings, specifications and other design submittals to permit CONTRACTOR to complete the work in accordance with the Contract.

2. CONTRACTOR shall provide through itself or subcontractors the necessary supervision, labor, inspection, testing, material, equipment, machinery, temporary utilities and other temporary facilities to permit performance of all demolition, earthwork, drainage, foundation work, maintenance of traffic, roadway work, structural work, excavation, erosion and sediment control work, field layout work, construction management and inspection, and all other work necessary to complete construction of the Project in accordance with the Contract. CONTRACTOR shall perform all design and construction activities efficiently and with the requisite expertise, skill and competence to satisfy the requirements of the Contract. CONTRACTOR at all times shall exercise control over the means, methods, sequences and techniques of construction. CONTRACTOR's operations and construction methods shall comply

with all applicable federal, state and local regulations with regard to worker safety, protection and health and protection of the environment and applicable permit requirements.

3. CONTRACTOR shall design and construct the project in such a manner that the construction limits are contained within the approved environmental footprint to the extent possible. Where new right of way is required to construct the Project, the CONTRACTOR shall design and construct the Project so as to minimize the additional rights of way needed. The acquisition of rights of way, including both cost and services to acquire, shall be the responsibility of the CONTRACTOR and shall be done in accordance with Article VIII of this Agreement. CONTRACTOR shall furnish the SCDOT a copy of any agreements for the use of additional properties not acquired as right of way that are used in conjunction with the construction of this Project. CONTRACTOR shall abide by the provisions of all applicable environmental permits, any conditions of individual right of way agreements, and all environmental commitments. The CONTRACTOR shall sign the NPDES co-permittee agreements and these agreements will be made part of the contract.

4. It shall be the responsibility of CONTRACTOR to determine and comply with all applicable federal, state, and local laws in connection with the services set forth in this Contract. This obligation shall include, but not be limited to, procurement of all permits and licenses not obtained by SCDOT provided, however, that with respect to any permit or licenses that must be obtained in the name of SCDOT, CONTRACTOR shall perform all functions within its power to obtain the permit, and SCDOT will fully cooperate in this effort and perform any functions that must be performed by SCDOT. CONTRACTOR shall be responsible for payment of all charges, fees, and taxes, and for providing all notices necessary and incident to the performance of the Project as of the Effective Date of this Agreement. The Contract Price shall include fees related to the above obligations and if any fees are waived by the regulatory or governmental entity, then the amount of the fee waived shall be deducted from the Contract Price.

C. Design Criteria

It shall be the responsibility of CONTRACTOR to design all aspects of the Project in accordance with the contract documents. For the Project, CONTRACTOR shall provide a completed set of construction plans signed and sealed by a licensed professional engineer in South Carolina. CONTRACTOR shall be fully responsible for the accuracy of the design and compliance with specifications, standards and Project Criteria.

D. Design Review

1. Within thirty (30) days prior to notice to proceed, CONTRACTOR, CONTRACTOR'S design consultant, subcontractors, suppliers and SCDOT shall meet to establish the sequencing procedures and schedule for submitting design plans for SCDOT's review. Within ten (10) days after this meeting, CONTRACTOR shall provide a Design Submittal Procedures and Schedule acceptable to SCDOT. CONTRACTOR, CONTRACTOR'S design consultant, subcontractors and suppliers shall not submit any design work until the Design Submittal Procedures and Schedule is approved by SCDOT. The Design Submittal Procedures

and Schedule will serve as the basis for reviewing the design and construction plans. The Design Submittal Procedures and Schedule shall be updated as requested by SCDOT

2. CONTRACTOR shall provide plans to SCDOT twenty-one (21) days prior to commencement of the next phase of work, in formats designated by SCDOT, so that SCDOT will have an opportunity to review the plans prior to commencement of construction activities. If more than one package is submitted within a seven day period, an additional seven (7) days per submittal package will be allowed for the reviews. Plans shall be submitted with all other reports and documents as defined in **EXHIBIT 4A**. SCDOT will have the right, but not the obligation, to review and comment upon the plans. CONTRACTOR shall respond to SCDOT review comments in written form within seven (7) days. SCDOT will then status CONTRACTOR's comments within seven (7) days. SCDOT review comments shall be resolved prior to commencement of construction, demolition or disposal activities. This review and comment is fully discretionary, however no review or comment nor any failure to review or comment shall operate to absolve CONTRACTOR of its responsibility to design and build the Project in accordance with the contract or to shift responsibility to SCDOT.

E. Maintenance of Traffic

The SCDOT work zone mobility requirements found within the documents known as *Rule on Work Zone Safety and Mobility: The Policy for South Carolina Department of Transportation* and *Rule on Work Zone Safety and Mobility: Implementation, Maintenance, and Safety Guidelines* shall apply to this project. These requirements apply to the CONTRACTOR, all subcontractors, all SCDOT staff and designated representatives acting on behalf of the SCDOT performing duties with responsibilities relative to a work zone, including but not limited to planning, project development, design, construction, and maintenance.

The CONTRACTOR shall design, develop, implement and maintain a set of coordinated strategies to manage the work zone impacts of the project designated as the Transportation Management Plan. These strategies will include a Temporary Traffic Control plan, a Transportation Operations component, and a Public Information component. The Policy and the anticipated work zone impacts of the project shall determine the level of detail, content, and scope of the TMP. The primary component, the Temporary Traffic Control plan shall address traffic control and safety throughout and adjacent to the project site. A secondary component, the Transportation Operations plan, will address management of traffic operations in the project site and all adjacent areas impacted by the project. The final component, the Public Information plan, addresses communications with the public and entities impacted by the project. Ensure the Transportation Management Plan and its components comply with the requirements of Part 6 of the Manual on Uniform Traffic Control Devices (MUTCD) latest edition and SCDOT policies, standard specifications and all addendums to the standard specifications, the typical traffic control standard drawings for road construction, and procedures.

F. Ownership of Documents

Drawings, specifications, test data, inspection reports, QC documents, daily diaries and any other documents, including those in electronic form, prepared by CONTRACTOR or CONTRACTOR's consultants are "Project Documents". CONTRACTOR

and CONTRACTOR's consultants shall be the owner of the Project Documents. Upon the Effective Date of this Agreement, CONTRACTOR grants SCDOT a nonexclusive license to reproduce the Project Documents for the purposes of, but not limited to, promoting, using, maintaining, upgrading, or adding to the Project. Upon completion of the Project or upon default by CONTRACTOR, CONTRACTOR shall provide copies of all Project Documents to SCDOT in the format designated by SCDOT.

G. Construction Criteria

CONTRACTOR shall construct the Project in accordance with all applicable Federal, State, and local statutes and regulations. All construction shall be performed in accordance with the following criteria, which are incorporated herein by reference and made a part hereof. The construction criteria are intended to be complementary and to describe and provide for a complete work. Where the following construction criteria conflict, the order of precedence shall be as listed below:

1. **EXHIBIT 4** – Project Criteria
2. **EXHIBIT 5** – Special Provisions
3. SCDOT Standard Drawings, effective as of the release of the Final RFP
4. SCDOT Supplemental Specifications and Supplemental Technical Specifications, effective as of the release of the Final RFP
5. SCDOT Standard Specifications for Highway Construction, effective as of the release of the Final RFP
6. SCDOT Construction Manual, effective as of the release of the Final RFP
7. SCDOT Approval Sheets, Material Acceptance Policies and New Products Evaluation Summary (available on SCDOT internet website)

H. Project Management

1. CONTRACTOR shall be responsible for ensuring that the Project is constructed in conformance with the Contract, all referenced documents and specifications, and applicable laws and regulations.

2. CONTRACTOR shall provide project management services sufficient to supervise the activities of his own personnel and subcontractors. CONTRACTOR shall provide a sufficient number of persons on site, to the satisfaction of SCDOT, to provide for the construction management of the Project.

3. SCDOT will provide representatives assigned to the Project to monitor the construction and provide necessary coordination between SCDOT and CONTRACTOR. All costs for salary and equipment to maintain SCDOT employees will be provided by SCDOT at no expense to CONTRACTOR. SCDOT and Federal Highway Administration (FHWA)

representatives will have full and complete access to the Project, the work in progress, the “Daily Diaries”, and to other technical documents and project records associated with design, construction, demolition, material disposal, materials, quality control, materials installation, and testing. SCDOT representatives will receive reasonable notice of and have the opportunity to participate in any meetings that may be held concerning the Project or the relationship between CONTRACTOR and their consultants and subcontractors when such meetings are associated with technical matters, progress, or quality of the Project. As used in this paragraph, “notice” shall require actual written notice to SCDOT’s Agent.

I. Control of the Work

1. CONTRACTOR shall determine the appropriate means, methods and scheduling necessary to complete the work timely and in accordance with all construction requirements. SCDOT and FHWA will have the right to review and inspect the work at any time.

2. If, at any time, SCDOT observes or has actual notice of any fault or defect in CONTRACTOR’s performance of this Agreement, SCDOT will give CONTRACTOR prompt written notice reasonably detailing the nature of the fault or defect. SCDOT is not required to discover or to accept defective or faulty work. SCDOT’s right to have defective or faulty work promptly corrected shall not be waived by any action of SCDOT.

3. SCDOT will have the authority to suspend the work, wholly or in part, for such periods, as SCDOT may deem necessary, due to CONTRACTOR’s failure to meet the requirements of the Contract in the performance of the work.

4. No inspection, acceptance, payment, partial waiver, or any other action on the part of SCDOT will operate as a waiver of any portion of this Agreement or of any power reserved herein or any right to damages or other relief, including any warranty rights, except insofar as expressly waived by SCDOT in writing. SCDOT will not be precluded or estopped by anything contained herein from recovering from CONTRACTOR any overpayment as may be made to CONTRACTOR.

J. Contract Deliverables

CONTRACTOR shall submit deliverables including, but not limited to, the following as set forth in the CONTRACT.

1. Contract Deliverable Matrix
2. Schedule of Values (**EXHIBIT 2**)
3. Plans - Article II.D.2
4. Erosion Control Plan (for entire project, in order to submit Notice of Intent (NOI))
5. Storm Water Pollutant Prevention Plan and Spill Prevention Plan
6. Traffic Management Plan

7. Crane Safety Plan
8. QC Plan
9. Public Relations Plan
10. Drainage Notebooks for the Project in accordance with SCDOT's Requirements for Hydraulic Design
11. CPM Schedule
12. EEO, DBE, and OJT Requirements, as specified in **EXHIBIT 7**
13. Right-of-Way documents per Article VIII
14. Shop Plans and working drawings
15. Preliminary & Final Geotechnical Reports
16. All final electronic design files for the Project, as specified in **EXHIBIT 4**
17. Escrow Proposal Documents
18. CONTRACTOR's Materials Certification
19. As-Built Plans
20. RR Agreement
21. HAZMAT surveys for bridges
22. Clearing and Grubbing Plan
23. Utility Coordination Reports and Utility Agreements
24. Right of Way Plats and Monuments (per Preconstruction Advisory Memorandum #8)

III. CONTRACT PRICE/CONTRACT PAYMENTS

A. Contract Price

The "Contract Price" shall be \$_____. In consideration for the Contract Price, CONTRACTOR shall perform all of its responsibilities under the Contract. The Contract Price shall include all work identified in the Project Scope of Work - **EXHIBIT 3**, and as identified in the Cost Proposal Bid Form – **EXHIBIT 1**.

B. Contract Price Adjustments

1. Allowable adjustments

The Contract Price may be adjusted to reflect the direct costs, plus an additional amount not to exceed 10% of the direct costs for the combined total of reasonable overhead* and profit, associated with any of the following:

- a) Amount added or deducted as the result of a “Change” or “Construction Change Directive”.
- b) Differing site condition as defined in Article XIII.
- c) Intentional or bad faith acts or omissions by SCDOT that unreasonably interfere with CONTRACTOR’s performance and cause delay of work on the critical path of the Project.
- d) Changes in legal requirements or regulations that are effective subsequent to the date of this Agreement.
- e) Discovery of hazardous materials as set forth in Article XI.
- f) Discovery of archeological or paleontological sites not previously identified as noted in Article X.
- g) Premium right-of-way costs and second appraisals as set forth in Article VIII. Only the actual premium right-of-way and actual second appraisal cost will be reimbursed. No additional amount for overhead and profit will be considered for this item.

* Overhead: The operating expense of a business exclusive of direct cost labor and material.

Other than as provided above, the Contract Price shall not be increased for contract time adjustments or delay damages. Contract Price adjustments shall be documented by Supplemental Agreement signed by both parties and shall be reflected immediately in the Schedule of Values. No claim by the CONTRACTOR for an adjustment hereunder shall be allowed if notice is not given prior to final payment under this Agreement.

2. Changes

- a) A “Change” shall be any deviation or variation from the Project Scope or the Project Criteria. No Change shall be implemented without the express written approval of SCDOT. A “Change” may be an “Additive Change” or a “Deductive Change”.
- b) SCDOT may initiate a change by advising CONTRACTOR in writing of the change. As soon thereafter as practicable, CONTRACTOR shall prepare and forward to SCDOT an estimate of cost or savings, and the impact to the schedule resulting from the change. SCDOT will advise CONTRACTOR in writing of its approval or disapproval of the change. If SCDOT approves the change, CONTRACTOR shall perform the Services as changed.

3. Construction Change Directive

A Construction Change Directive is a written order from SCDOT directing a change prior to agreement with CONTRACTOR on adjustment, if any, to the Contract Price or Contract Time. If a price for the work cannot be agreed upon, CONTRACTOR shall perform the work under Force Account Procedures as outlined in Section 109.5 of SCDOT's Standard Specifications.

4. Direct Costs

For the purpose of a Contract Price Adjustment, "Direct Costs" shall be defined as:

- a) Costs of labor, including social security, old age and unemployment insurance, fringe benefits required by agreement or custom, and workers' compensation insurance;
- b) Costs of materials, supplies, and equipment, including cost of transportation, whether incorporated or consumed;
- c) Actual costs of machinery and equipment owned by CONTRACTOR or any affiliated or related entity exclusive of hand tools;
- d) Actual costs paid for rental of machinery and equipment exclusive of hand tools;
- e) Costs of premiums for all bonds and insurance, permit fees, and sales, use or similar taxes;
- f) Additional costs of supervision and field office personnel directly attributable to the change or event; and
- g) Costs incurred or fees paid for design work related to the change or event.

C. Contract Payments

1. Schedule of Values

Prior to execution of this Agreement, CONTRACTOR shall provide a Schedule of Values acceptable to SCDOT and work may not start until the Schedule of Values is approved by SCDOT. The Schedule of Values will serve as the basis for cost loading of the CPM Schedule. The CPM schedule shall include sufficient information to provide for monetary and quantitative tracking of the work by SCDOT. Updates to the cost-loaded CPM schedule will serve as the basis for progress payments requested by and made to CONTRACTOR. If the Contract Price is adjusted, CONTRACTOR shall revise its Schedule of Values and the CPM Schedule to reflect the adjustment in the Contract Price. The revised Schedule of Values must be approved by SCDOT prior to the time for the subsequent request for a progress payment

otherwise no progress payments will be made. The Schedule of Values shall be incorporated herein as **EXHIBIT 2**. The Schedule of Values should include Lump Sum items that will serve as measurement and payment for any item referred to in this Contract as a “contract unit bid price” item.

2. Mobilization

Mobilization shall not exceed 5% of the construction cost as shown in the Schedule of Values. Mobilization will be paid at the start of construction.

3. Periodic Progress Payment Applications

No application for payment of the Contract Price shall be submitted until SCDOT gives a notice to proceed. Applications for payment of the Contract Price may be submitted once a month. Each application for payment of the Contract Price shall set forth, in accordance with the Schedule of Values and the cost-loaded CPM schedule, the percentage of all items comprising the work completed since CONTRACTOR’s immediately prior request for payment. The application for payment of the Contract Price may also request payment for equipment and materials not yet incorporated into the Project, provided that (i) SCDOT is satisfied that the equipment and materials are suitably stored at either the Project or another acceptable location, (ii) the equipment and materials are protected by suitable insurance and (iii) upon payment, SCDOT will receive title to the equipment and materials free and clear of all liens and encumbrances.

4. Periodic Progress Payments

SCDOT will review each application for payment. Upon approval by SCDOT of an application for payment, SCDOT will pay CONTRACTOR the undisputed percentage for the Project completed during the period covered by the application for payment. SCDOT will make each payment within twenty-one (21) days of the receipt of the corresponding Application for Payment. In the event of a dispute over the quality of work or percentage of the Project completed, SCDOT’s decision is controlling and final. Payment by SCDOT will not preclude or estop SCDOT from correcting any measurement, estimate, or certificate regarding the percentage completion of the Project, and future payments may be adjusted accordingly.

5. Prompt Payment of Subcontractors

a) Subject to the provisions on retainage provided in Paragraph (b) below, when a subcontractor has satisfactorily performed a work item of the subcontract, CONTRACTOR must pay the subcontractor for the work item within seven (7) calendar days of CONTRACTOR’s receipt of payment from SCDOT. A subcontractor shall be considered to have "satisfactorily performed a work item of the subcontract" when SCDOT pays CONTRACTOR for that work item.

b) CONTRACTOR may withhold as retainage up to five (5%) percent of a subcontractor's payment until satisfactory completion of all work items of the subcontract. "Satisfactory completion of all work items of the

subcontract" shall mean when SCDOT pays CONTRACTOR for the last work item of the subcontract. CONTRACTOR must release to the subcontractor any retainage withheld within seven (7) calendar days from the date CONTRACTOR receives payment from SCDOT for the last work item of the subcontract. For further information regarding Retainage, see Article III, paragraph D.

c) With each progress payment application, CONTRACTOR shall certify to SCDOT that the payment application is complete and that all subcontractors have been paid for work covered by previous applications.

d) Failure to comply with any of the above provisions shall result in one or more of the following sanctions: (1) no further payments to CONTRACTOR unless and until compliance is achieved; (2) CONTRACTOR being placed in default; and/or (3) CONTRACTOR being declared delinquent, such delinquency being subject to procedures and penalties provided in 108.8 of the Standard Specifications.

6. Withholding of Payment

SCDOT may withhold all or part of any payment under the Contract because for any of the reasons listed below. Any funds withheld will be released upon CONTRACTOR satisfactorily remedying the defect, fault, or failure and will be included in the next regularly schedule pay estimate. Payment will be subject to retainage if applicable.

a) Defective work not remedied. Any such withholding, however, shall not exceed two times the reasonable cost of remedying the defective work. Defective work shall be defined as work or material not conforming to the requirements of the Contract.

b) Reasonable evidence that the Work will not be Substantially Complete within the Contract Time as adjusted and that the unpaid balance of the Contract Price will not be adequate to cover Liquidated Damages for the actual unexcused delay;

c) Failure to comply with the prompt payment provision of this Contract;

d) Any fines or other charges to SCDOT due to CONTRACTOR's failure to comply with permit requirements or other regulations;

e) Notice of cancellation of insurance;

- f) Failure to submit updated and approved CPM or Schedule of Values;
- g) Violation of QC plan requirements;
- h) Failure to follow specifications or procedures required by the Contract;
- i) Failure to comply with DBE, or Pre-Employment Training provisions;
- j) Failure to provide adequate work zone traffic control;
- k) Failure to provide adequate sediment and erosion control; or,
- l) Violation of any contract provisions.

D. Retainage

Provided the Project is proceeding satisfactorily, SCDOT will not withhold retainage. However, if at any time SCDOT determines that CONTRACTOR fails to meet contract terms or the Project is not proceeding satisfactorily, SCDOT may retain up to 10% of the Contract Price as retainage. If the reason for SCDOT's withholding of retainage is attributable to a subcontractor's failure to perform, CONTRACTOR may withhold up to 10% of the subcontractor's payment until all work of the subcontract work is satisfactorily performed. If it decides to withhold retainage, SCDOT will not withhold more than 20% of any single payment application. SCDOT will have sole authority to determine the amount (not exceeding 10%) and necessity of retainage.

IV. CONTRACT TIME

A. Project Schedule

1. Time for Completion of Project. The Project shall be Substantially Complete within 1277 calendar days from full notice to proceed. Time is of the essence.

2. Substantial Work Completion. The Project shall be considered substantially complete when it is serviceable to the public, all lanes and ramps are open, and all work is completed except for "Project Close-out Activities", "Project Close-out Activities" are defined as punch list items, site clean-up, demobilization, and final Project documentation, including but not limited to as-built plans.

3. Critical Path Method Schedule: CONTRACTOR shall prepare and maintain a schedule for the Project using the Critical Path Method of scheduling (hereinafter called "CPM Schedule"). Prepare the schedule in accordance with this agreement and the SCDOT Supplemental Specifications (**EXHIBIT 6**) with the following exceptions:

- a) Submit to the SCDOT the initial baseline CPM schedule within 30 days from the Effective Date of this Agreement. No contract payment will be made to Contractor and no construction work may begin until a CPM baseline schedule is received and accepted by SCDOT. Update the baseline CPM schedule for monetary and quality tracking purposes as Released for Construction plans are developed.
- b) Cost-load the CPM schedule using the expenses identified in the schedule of values. Use the schedule of values to establish Expense Categories and assign to the correct activities.
- c) Include submittal activities. Allow duration for these activities to include SCDOT review periods.
- d) Reuse of deleted activity ID's from schedule update to schedule update is not allowed.
- e) Failure to include any element of work or any activity including but not limited to utility relocation, right of way acquisition, and permitting will not relieve the CONTRACTOR from completing all work within the Contract Time at no additional time or cost to the SCDOT, notwithstanding the acceptance of the schedule by SCDOT.
- f) Develop project specific calendars reflecting all seasonal restrictions included in this Agreement and non-work days. Address durations for weather within activity duration, not within the calendar.
- g) Use only a Work Breakdown Structure (WBS) to organize schedule activities. At a minimum, breakout the design and construction phases. These 2 breakouts should have the same parent within the structure.
- h) Submit monthly updates no later than 15 days following the most recent estimate period end date. Set the data date the same as the most recent estimate period end date.
- i) If SCDOT determines any schedule submission is deficient, it will be returned to the CONTRACTOR. A corrected schedule shall be provided within 7 calendar days from the SCDOT's transmittal date.
- j) The schedule may indicate an early completion date. However, SCDOT will not be liable in any way for CONTRACTOR's failure to complete the Project prior to the specified Contract Time. Any additional costs, including extended overhead incurred between CONTRACTOR's scheduled completion date and the Contract Time, shall be the responsibility of the CONTRACTOR.
- k) The schedule may include constraints to indicate the early completion of portions of the work. SCDOT will remove these constraints when determining the critical path of the schedule.
- l) Include in each narrative a detailed listing of crews utilized on activities and their responsibilities. In lieu of this, the Contractor may request to submit a Resource Loaded CPM schedule.

4. Progress Review Meetings.

a) Review Meetings shall be held between CONTRACTOR and SCDOT at least every 2 weeks. Periodic construction meetings shall be held by CONTRACTOR with its consultants and subcontractors to coordinate the work, update the schedule, provide information and resolve potential conflicts.

b) SCDOT and CONTRACTOR will hold a regular CPM Progress Meeting at which all principal parties are expected to attend. These meetings will be held the week before the application for payment is due so that job progress will coincide with the payment application. At this meeting, CONTRACTOR shall provide the most recent schedule with notations showing actual start dates, actual finish dates, and activity progress. If the schedule provided indicates an actual or potential delay to the completion of the Contract, CONTRACTOR shall provide a narrative identifying the problems, causes, the activities affected and describing the means and methods available to complete the Project by the Contract Time.

5. Final Completion. When CONTRACTOR believes that all elements of its work on the Project, including all of the requirements of the Contract, have been completed, it shall notify SCDOT in writing. Final Completion shall be achieved within 180 calendar days of Substantial Work Completion as defined in this Agreement. Within thirty (30) days thereafter, SCDOT will acknowledge project completion or will advise CONTRACTOR in writing of any aspect of the Contract or the Project Scope that is incomplete or unsatisfactory. CONTRACTOR shall complete all corrective action within thirty (30) days after written notification of incomplete or unsatisfactory items. CONTRACTOR will notify SCDOT in writing upon completion of necessary corrective action. SCDOT will verify satisfactory completion of the corrective action in writing to CONTRACTOR. Upon verification, the Project shall be deemed to have achieved Final Completion.

6. Inspection/Acceptance; No Waiver. No inspection, acceptance, payment, partial waiver, or any other action on the part of SCDOT will operate as a waiver of any portion of this Agreement or of any power reserved herein or any right to damages or other relief, including any warranty rights, except insofar as expressly waived by SCDOT in writing. SCDOT will not be precluded or estopped by anything contained herein from recovering from CONTRACTOR any overpayment as may be made to CONTRACTOR.

B. Contract Time Adjustments

The Contract Time may be extended if there is a delay to the critical path of the Project caused by an event listed below. All requests for time extensions shall be made in writing to SCDOT within 20 days of the event causing the delay. All time extensions must be approved in writing by SCDOT. Time extensions may be allowed for the following events that affect the critical path:

1. Force Majeure as that term is defined in this Agreement in Article XIV;

2. Changes or construction change directives;
3. Differing site conditions as defined under Article XIII;
4. Injunctions, lawsuits, or other efforts by individuals or groups that hinder, delay, or halt the progress of the Project, provided that such efforts are not premised on alleged wrongs or violations by CONTRACTOR or its subcontractors;
5. Interference with or delay of work on the critical path of the Project by SCDOT; however, CONTRACTOR shall not be entitled to a time extension if SCDOT's actions are necessitated by CONTRACTOR's actions, omissions, failure to perform quality work, or failure to comply with contract requirements;
6. Changes in the legal requirements or regulations which are effective subsequent to the date of this Agreement;
7. Discovery of hazardous materials as set forth in Article XI; or,
8. Discovery of archeological or paleontological remains not previously identified as set forth in Article X.

C. Owner's Right to Stop Work

SCDOT will have the authority to suspend the work, wholly or in part, for such periods, as SCDOT may deem necessary, due to CONTRACTOR's failure to meet the requirements of the Contract in the performance of the work. Such suspension of the work shall not constitute grounds for claims for damages, time extensions, or extra compensation.

D. Liquidated Damages

CONTRACTOR shall pay liquidated damages to SCDOT in the amount of Seven Thousand Five Hundred Dollars (\$7,500.00) for each day for which construction is not substantially complete, as defined in Article IV.

CONTRACTOR shall pay liquidated damages to SCDOT in the amount of One Thousand Five Hundred Dollars (\$1,500.00) for each day that Final Completion, as defined in Article IV is not achieved.

V. QUALITY ASSURANCE PROGRAM

A. CONTRACTOR's Responsibilities

CONTRACTOR shall be responsible for the QUALITY CONTROL Portion of the Program to include the items listed below. Work shall not commence until CONTRACTOR has met these requirements.

1. Quality Control Plan: CONTRACTOR shall submit a Quality Control Plan that outlines how CONTRACTOR shall assure that the materials and work are in compliance with the drawings, plans, standard specifications, contract special provisions, SCDOT Construction Manual, Inspection Training Manuals, RFP and all attachments. The Quality Control Plan shall also include the specific portions of the Transportation Management Plan that address the work item. The initial plan shall be submitted to SCDOT for review and approval at least seven (7) days prior to any design or plan submittal or the beginning of any construction activity. The plan shall be updated as necessary prior to the start of any specific construction operation. The plan shall include a list of certified SCDOT personnel responsible for management and quality control of the Project, and define the authority of each individual. The plan shall also include how CONTRACTOR will monitor quality and deal with failing materials. CONTRACTOR shall include an estimated summary of quantities to SCDOT for the purposes of meeting the minimum sampling and testing requirements in accordance with the SCDOT Construction Manual.

2. Personnel: CONTRACTOR shall provide a sufficient number of **SCDOT certified SCDOT personnel** to adequately control the work of the Project. Any personnel required to obtain samples or conduct material testing shall be certified or adequately trained and qualified as determined by SCDOT. Training, qualification, and/or certification shall include classroom training, written testing, documented demonstration of proper inspection, sampling and testing procedures, pre-employment training and an on-the-job training period. CONTRACTOR shall provide SCDOT with copies of each individual's training, qualifications, and/or certifications, in resume form, as required, for review and approval by SCDOT. Approved CONTRACTOR QC personnel shall be on the job at all times that the CONTRACTOR is on-site actively involved in work.

3. CONTRACTOR Testing: CONTRACTOR is required to conduct asphalt sampling and testing in accordance with QC/QA special provisions and supplemental specifications for asphalt included in **EXHIBITS 5 and 6** and the SCDOT Supplemental Technical Specifications. CONTRACTOR may elect to conduct other sampling and testing for its own benefit. The cost of these activities will be borne by CONTRACTOR. Additionally, **if required by design**, CONTRACTOR is responsible for dynamic and static load testing of drilled shafts and piles in accordance with the requirements of **EXHIBITS 4 and 5**.

4. Testing Laboratories: All testing laboratories used on the Project must be AASHTO certified and approved by SCDOT thirty (30) days prior to beginning the portion of work for which the laboratory will be performing the testing.

5. Mix Designs: Copies of all initial hot-mix asphalt mix designs and Portland Cement Concrete mix designs, along with supporting data, shall be submitted to SCDOT for review at least seven (7) days prior to use. All hot-mix asphalt mix designs will be prepared by personnel certified in Mix Design Methods. Portland Cement Concrete mix designs will be prepared by a certified concrete technician or a Professional Engineer. The Portland Cement Concrete mix proportions given in the specifications are to be followed. CONTRACTOR shall design the mix to obtain the strength and

water/cement ratios given in the specifications, and shall provide workability, air content, gradation and suitable set times as set forth in the Standard Specifications. The SCDOT will be notified of any revisions to CONTRACTOR's mix design. Copies of such revisions will be sent to SCDOT for review at least fourteen (14) days prior to use.

6. Materials Certifications: CONTRACTOR shall submit all material certifications for approval by SCDOT prior to the CONTRACTOR incorporating the material and applying for payment for work in which the material was incorporated. Upon Completion of the project, CONTRACTOR shall submit to SCDOT a letter of certification stating that, based upon an analysis of all materials test results, all materials incorporated into the Project were found to be in substantial conformance with the requirements of the plans and specifications. A list of any exceptions and all failing test results will be provided, along with a record of disposition of the material represented by these tests.

B. SCDOT Responsibilities

SCDOT will be responsible for the QUALITY ACCEPTANCE portion of the program to include: conducting inspections, acceptance testing, independent assurance testing and final project material certification.

1. Acceptance Testing: SCDOT personnel assigned to the Project, or qualified personnel retained by SCDOT, will conduct sampling and testing, separate from CONTRACTOR's testing, at the frequencies set forth in SCDOT's construction manual. This testing will be used by SCDOT to determine the acceptability of the materials. All sampling and testing will be in accordance with existing AASHTO, ASTM, or SC test methods used by SCDOT. The cost of these activities will be borne by SCDOT. CONTRACTOR is required to coordinate its activities closely with SCDOT to allow the necessary acceptance testing to be conducted prior to proceeding to the next operation. The disposition of failing materials must be approved by SCDOT.

2. Independent Assurance Testing: SCDOT will be responsible for conducting Independent Assurance Testing. Personnel performing these tests will be SCDOT employees or qualified persons retained by SCDOT. Persons performing these tests will not be involved in Acceptance Testing. This testing will be used to ensure that proper sampling and testing procedures are being followed, and that testing equipment is functioning properly. This testing will consist of observing sampling and testing by both SCDOT personnel performing Acceptance Testing and CONTRACTOR personnel performing Quality Control Testing, as well as taking split samples for the purposes of comparison testing. Independent Assurance Testing will be at an approximate frequency of one-tenth of the Acceptance Testing frequency. Independent Assurance test results will not be used for acceptance. The cost of these activities will be borne by SCDOT.

3. Materials Certification: SCDOT will be responsible for preparing the Materials Certification as required by the FHWA on federally funded projects.

C. CONTRACTOR's Obligation

SCDOT's testing in no way relieves CONTRACTOR of its obligation to comply with the Contract requirements. All materials incorporated into the Project must meet or exceed contract requirements and specifications. Further, any testing by SCDOT will not relieve CONTRACTOR of any of its warranty obligations.

VI. INSURANCE AND BONDING

A. Insurance

1. CONTRACTOR shall purchase and maintain in a company or companies that maintain an A.M. Best rating of not less than A-VII with coverage forms acceptable to SCDOT. The insurance described below shall be maintained uninterrupted for the duration of the Project, including warranty periods, and shall protect CONTRACTOR from claims set forth below which may arise out of or result from CONTRACTOR's operations under the Contract, whether such operations be performed by CONTRACTOR or by any subcontractor or by anyone directly or indirectly employed by any of them or by anyone for whose acts any of them may be liable:

- a) Claims under workers' or workmen's compensation, disability benefit and other similar employee benefit acts;
- b) Claims for damages because of bodily injury, occupational sickness or disease, or death of CONTRACTOR's employees;
- c) Claims for damages because of bodily injury, sickness or disease, or death of any person other than CONTRACTOR's employees;
- d) Claims for damages insured by usual personal injury liability coverage which are sustained (1) by any person as a result of an offense directly or indirectly related to the employment of such person by CONTRACTOR, or (2) by any other person;
- e) Claims for damages, other than to the work itself, because of injury to or destruction of tangible property, including loss of use resulting therefrom;
- f) Claims for damages because of bodily injury or death of any person or property damage arising out of the ownership, maintenance or use of any motor vehicle.
- g) Claims involving contractual liability insurance applicable to the Contractor's obligations under the indemnity provisions of this contract.

2. The minimum limits of liability for the following types of insurance are required, except where greater limits are required by statute:

a) Workers' Compensation, including: Worker's Compensation
Insurance/Employer's Liability

State Statutory limits	Employer's Liability
	\$100,000 per accident
	\$500,000 per disease
	\$100,000 each employee

- b) Commercial General Liability \$1,000,000 per occurrence
\$2,000,000 aggregate

Commercial General Liability insurance shall be written on ISO occurrence form CG 00 01 (or substitute for providing equivalent coverage) and shall cover liability arising from premises, operations, independent contractors, products-completed operations, contractual liability and personal injury and advertising injury. The policy shall contain the per project endorsement.

- c) Business Automobile Liability \$1,000,000 per occurrence

This policy shall cover Any Auto, including Owned, Hired and Non-owned Automobiles. Business auto coverage shall be written on ISO form CA 00 01, CA 00 05, CA 00 12, CA 00 20, or a substitute form providing equivalent liability coverage.

- d) Umbrella Liability Coverage \$10,000,000 per occurrence
\$20,000,000 aggregate

The general aggregate limit shall apply separately to the Project

3. Certificates of Insurance acceptable to SCDOT will be provided to SCDOT prior to commencement of the work. These certificates shall name SCDOT as an additional insured under the Commercial General Liability (CGL) arising out of both the on-going operations and completed operations of CONTRACTOR. Such additional insured coverage shall be endorsed to Contractor's CGL policy using ISO Additional Insured Endorsement form CG 2010 (10/01) and CG 2037 (10/01) or a substitute providing equivalent coverage, and included under the commercial umbrella. CONTRACTOR shall maintain continual additional insured status for SCDOT under the products-completed operations coverage for the time period required to satisfy the statute of limitation for South Carolina. CONTRACTOR shall also name SCDOT as additional insured under Business Automobile and Umbrella policies and reference the Project to which the certificate applies. The policies must contain a provision that coverage afforded will not be canceled until at least 30 days prior written notice has been given to

SCDOT. Verification of additional insured status shall be furnished to SCDOT by including a copy of the endorsements with the Certificate of Insurance. This insurance, including insurance provided under the commercial umbrella shall apply as primary and noncontributory insurance with respect to any other insurance or self-insurance programs, including any deductibles, afforded to, or maintained by, SCDOT.

4. Limits shown in this provision are minimum acceptable limits and in no way limit available coverage to the additional insured. CONTRACTOR's CGL and commercial umbrella policies shall contain no provision providing that the limits available to an additional insured are less than the limits available to the CONTRACTOR. SCDOT shall be given all the same rights and insurance coverage as CONTRACTOR. In the event that any insurer issues a reservation of rights for SCDOT as an additional insured, SCDOT shall be entitled to employ independent counsel, of its choice, at CONTRACTOR's expense.

5. There shall be no endorsements or modifications of the CGL limiting the scope of coverage for liability arising from explosion, collapse, underground property damage or work performed by contractors on behalf of SCDOT.

6. Hazardous waste. If the CONTRACTOR is required to remove and haul any hazardous waste from the Project, or if the Project involves such similar environmental exposure, pollution liability coverage equivalent to that provided under the ISO Pollution Liability – Broadened Coverage for Covered Autos Endorsement (CA 99 48) shall be provided, and the Motor Carrier Act Endorsement (MCS 90) shall be attached. Limits of pollution liability shall be not less than \$1,000,000 per occurrence. Coverage shall apply on an “occurrence form” basis, shall cover at a minimum bodily injury, property damage, defense costs and clean-up costs and be extended to include non-owned disposal sites and transportation coverage. This insurance shall remain in effect after acceptance by Owner for the time period required to satisfy the status of limitations in South Carolina. However, if coverage is written on a “claims made form”, then the Contractor's Pollution Liability coverage shall include a retroactive date that precedes the commencement of work under this Agreement. Such coverage shall apply as primary and non-contributory insurance with respect to any other insurance or self-insurance programs, including any deductibles, afforded to, or maintained by SCDOT.

7. Waiver of Subrogation. CONTRACTOR shall waive its rights against SCDOT, other additional insured parties, and their respective agents, officers, directors and employees for recovery of damages, or any other claims, to the extent these damages are covered by the CGL, business auto, workers compensation and employer's liability or commercial umbrella maintained pursuant to this section of the Agreement.

8. CONTRACTOR shall at the time of execution of this Agreement, obtain Errors and Omissions insurance for their Professional Liability, for all claims arising from the performance of professional services on the Project. The insurance coverage shall be for not less than Three Million Dollars (\$3,000,000) per claim and in the aggregate. The coverage shall be continued for three (3) years after the date of Final

Completion of the Project. Evidence of such insurance shall be provided to SCDOT at the time of the execution of the Agreement.

9. CONTRACTOR shall provide “Builders Risk Insurance” acceptable to the SCDOT in the amount of the Contract Price protecting the respective interests of SCDOT and CONTRACTOR and covering physical loss or damage to the work during construction of the Project. The certificate of insurance shall be provided to the SCDOT at the time of execution of this Agreement. The policy shall name the SCDOT as an additional insured and shall reference the Project by name. The certificate shall also state that the coverage will not be cancelled or reduced without 30 days prior written notice to the SCDOT.

10. After completion of the work, CONTRACTOR shall maintain CGL and commercial umbrella coverage to include liability coverage for damage to insured’s completed work equivalent to that provided under ISO CG 00 01 for three (3) years or for the statute of limitations period for damages, whichever is greater.

B. Bonding

1. CONTRACTOR shall at the time of the execution of this Agreement, provide SCDOT the following bonds:

a) A Performance and Indemnity Bond from a surety or sureties satisfactory to SCDOT. The amount of bond shall be equal to the Contract Price.

b) A Payment Bond from a surety or sureties satisfactory to SCDOT. The amount of bond shall be equal to the Contract Price.

These bonds shall be in accordance with the requirements of S.C. Code Ann. §57-5-1660, (1976 as amended) and S.C. Code Ann. §29-6-250 (2000).

2. CONTRACTOR shall also provide a warranty bond, acceptable to SCDOT, in the amount of Three Million Dollars (\$3,000,000) to cover the warranty obligations of the contract.

VII. UTILITIES AND RAILROAD COORDINATION

A. As part of the Project Scope, CONTRACTOR shall have the responsibility of coordinating the Project construction and demolition activities with all utilities that may be affected. CONTRACTOR shall be responsible for the cost of utility coordination as defined herein. If applicable, all temporary relocation costs as well as any other conflict avoidance measures shall be the responsibility of the CONTRACTOR. For those utilities that have prior rights, SCDOT will be responsible for relocation costs as defined by the Federal code. For those utilities where the CONTRACTOR determines that the SCDOT has prior rights, CONTRACTOR may exercise these rights and require the utility company to bear the costs of relocation. If there is a dispute over prior rights, SCDOT shall be responsible for resolving the dispute. SCDOT shall have final determination of the utility’s prior rights.

B. For those utilities requiring relocation, CONTRACTOR shall conform with SCDOT's "A Policy for Accommodating Utilities on Highway Rights of Way", the applicable State laws, and the Code of Federal Regulations, Title 23, Chapter 1, Subchapter G, part 645, subparts A and B.

C. The resolution of any conflicts between utility companies and the construction of the Project shall be the responsibility of CONTRACTOR. No additional compensation (time or dollars) will be allowed for any delays, inconveniences or damage sustained by CONTRACTOR or its subcontractors due to interference from utilities or the operation of relocating utilities.

D. CONTRACTOR shall meet with the Department's Utilities Office within seven (7) days of the notice to proceed to gain a full understanding of what is required with each utility submittal.

E. CONTRACTOR shall design the Project to avoid conflicts with utilities where possible, and minimize impacts where conflicts cannot be avoided. If there is a dispute between the CONTRACTOR and SCDOT as to whether a utility relocation is required, SCDOT shall have the final determination. Additional utility relocations desired by the CONTRACTOR for but not limited to construction staging, access or convenience, shall be the sole responsibility of CONTRACTOR and all associated costs shall be borne by the CONTRACTOR.

F. CONTRACTOR shall initiate early coordination with all utilities and provide the utility companies with design plans for their use in developing Relocation Sketches as soon as the plans have reached a level of completeness adequate to allow the companies to fully understand the Project impacts. If a party other than the utility company prepares Relocation Sketches, there shall be a concurrence box on the plans where the utility company signs and accepts the Relocation Sketches as shown.

G. CONTRACTOR shall be responsible for collecting and submitting to SCDOT the following from each utility company that is located within the project limits:

1. **Relocation Sketches** including letter of "no cost" where the company does not have a prior right;
2. **Utility Agreements** including cost estimate and relocation plans where the company has a prior right; and/or
3. **Letters of "no conflict"** where the company's facilities will not be impacted by the Project.
4. **Encroachment Permits** for all relocations regardless of prior rights.

H. CONTRACTOR shall assemble the information included in the Utility Agreements and Relocation Sketches in a final and complete form and in such a manner that the Department may approve the submittals with minimal review. CONTRACTOR shall ensure that there are no conflicts with the proposed highway improvements, or between each of the utility company's relocation plans. CONTRACTOR may not authorize the utility companies to begin

their relocation work until authorized in writing by SCDOT. Any early authorization by CONTRACTOR shall be at the CONTRACTOR's risk.

I. At the time that CONTRACTOR notifies SCDOT that CONTRACTOR deems the Project to have reached Final Completion, CONTRACTOR shall certify to SCDOT that all utilities have been identified and that those utilities with prior rights or other claims related to relocation or coordination with the Project have been relocated or their claims otherwise satisfied or will be satisfied by CONTRACTOR.

J. CONTRACTOR shall accurately show the final location of all utilities on the as-built drawings for the Project.

In the event railroad property is impacted by this project, provisions K through S shall apply:

K. Under the direction of and in coordination with SCDOT, the CONTRACTOR shall be responsible for all coordination with the involved Railroad Companies, including but not limited to, sending plans, meetings, correspondence, phone calls, writing/reviewing agreements, and etc. as may be necessary to secure the applicable executed railroad agreements, needed for the construction of the project, between the SCDOT and all involved railroad companies. All correspondence related to railroad agreements or conditions shall include the railroad file number and railroad milepost information. The CONTRACTOR shall be responsible for the cost of railroad coordination as defined herein.

L. SCDOT will submit for approval, all required railroad agreements necessary for the Preliminary Engineering and Construction of the project. Upon approval, the SCDOT will submit the agreement to the Railroad Company for execution. The CONTRACTOR shall be responsible for assisting SCDOT in the development of the railroad agreement by providing requested information.

M. The CONTRACTOR shall be responsible for all costs to the Railroad Company or Companies for services provided by the Railroad or the Railroad's Agent, as detailed in the executed Railroad Agreement between the SCDOT and the Railroad. This includes all expenses such as railroad flagging operations. The CONTRACTOR shall be responsible for all other costs associated with designing and constructing the project as described in the executed Railroad Agreement between the SCDOT and the Railroad Company. The CONTRACTOR shall include all costs associated with these requirements in the final bid price. Once a contract is executed, SCDOT shall administer invoicing for costs to the Railroad Company or Companies. Monies will be deducted from the CONTRACTOR's progress payments.

N. All design and construction activities in, adjacent to, over or under the railroad shall comply with all applicable Federal and State laws and standards, all terms identified in the Special Provisions for Protection of Railway Interests, and all terms of the final agreement executed with the Railroad Company.

O. The CONTRACTOR will be required to meet the Railroad's Insurance Requirements as specified in the Special Provisions for Protection of Railway Interests.

P. The CONTRACTOR shall attend a mandatory meeting with the SCDOT's Utilities Office and Railroad Projects Office within thirty (30) days of the Notice to Proceed. The CONTRACTOR will be required to use the SCDOT approved agreement language and procedures, that will be provided in this meeting.

Q. SCDOT has negotiated language for the PE and Construction Agreements (see example in Project Information Package). CONTRACTOR shall provide project specific information to SCDOT for inclusion into the agreements. The CONTRACTOR shall anticipate and include in the proposed schedule a minimum 90-day approval time-frame for all railroad agreements. However, SCDOT will not be held responsible for delays caused by negotiations with the railroad company.

R. CONTRACTOR shall anticipate the need for a separate right-of-entry agreement between the CONTRACTOR and Railroad for surveys, borings, etc. The required PE Agreement, between SCDOT and Railroad, must be executed before Railroad will review or comment on any design questions or submittals from the CONTRACTOR. The Construction Agreement, between SCDOT and Railroad, must be executed before any construction activities can begin.

S. CONTRACTOR is advised the all utility relocations required within railroad right-of-way will require separate agreements between the affected utility company and the Railroad.

VIII. RIGHT OF WAY ACQUISITION

A. Right of Way Services

CONTRACTOR, acting as an agent on behalf of the State of South Carolina, shall provide right-of-way services for the Project. CONTRACTOR shall use firm(s) from the SCDOT's current "on-call" list for right of way consultants, as listed in Attachment B, to provide right of way services. Right-of-way services shall include appraisal, appraisal review, negotiation, acquisition, and relocation assistance services. CONTRACTOR shall be responsible for all costs related to these right-of-way services. CONTRACTOR will provide expert testimony and SCDOT will provide legal services necessary for any cases that are to be resolved by trial. Experts are defined as engineering and appraisal witnesses. SCDOT will retain final authority for approving just compensation, relocation benefits and settlements. SCDOT will designate a hearing officer to hear any Relocation Assistance Appeals. SCDOT agrees to assist with any out of state relocation by persons displaced within the rights of way by arranging with such other state(s) for verification of the relocation assistance claim. CONTRACTOR shall carry out the responsibilities as follows:

1. Acquire property in accordance with all Federal and State laws and regulations, including but not limited to the Uniform Relocation and Real Property

Acquisition Act of 1970, as amended (the “Uniform Act”) and the South Carolina Eminent Domain Procedure Act (“The Act”). The acquisition of property shall follow the guidelines as established by the Department and other State and Federal guidelines. CONTRACTOR shall not be entitled to an increase in the Contract Price for acquisition of borrow sources.

2. Submit procedures for handling right-of-way acquisitions and relocations to the SCDOT for approval prior to commencing right-of-way activities. These procedures are to show CONTRACTOR’S method including the appropriate steps and workflow required for appraisal, acquisition, and relocation. CONTRACTOR shall be granted the authority for administrative settlements by the SCDOT’s Right-of-Way Office upon review and approval of the Right-of-Way Procedures. These procedures should also include an appropriate time allowance for SCDOT to establish just compensation, approve relocation benefits, and approve administration and legal settlements. A SCDOT Representative will be available to make timely decisions concerning establishing just compensation, approving relocation benefits, and approving administrative settlements on behalf of SCDOT. The SCDOT Representative is committed to issuing decisions on approval requests within three (3) business days. The commitment is based on the plan providing a reasonable and orderly workflow and the work being provided to the SCDOT Representative as completed.

3. Utilize SCDOT’s right-of-way project tracking system and provide an electronic status update a minimum of twice per month or upon request by SCDOT’s representative.

4. Submit a right-of-way quality control plan to the SCDOT for review prior to commencing right-of-way activities. SCDOT standard forms and documents will be used to the extent possible.

5. Provide a toll free telephone number for landowners and displaced persons to call.

6. Provide a current title certificate by a licensed South Carolina attorney for each parcel as of the date of closing or the date of filing of the Condemnation Notice.

7. Prepare appraisals in accordance with the Department’s Appraisal Manual. Appraisals shall be prepared by appraisers who are on the SCDOT approved list of active fee appraisers.

8. Provide appraisal reviews complying with technical review guidelines of SCDOT Appraisal Manual and make a recommendation of just compensation. The reviewer shall be from the SCDOT’s approved reviewer list.

9. Make direct payments of benefits to property owners for negotiated settlements, relocation benefits and payments to be deposited with the court and notify SCDOT monthly of payments made.

10. Prepare, obtain execution of, and record documents conveying title to such properties to SCDOT with Register of Deeds, and deliver all executed and recorded general warranty deeds to SCDOT. For all property purchased in conjunction with the Project, title will be acquired in fee simple (except that SCDOT may in its sole discretion direct the acquisition of a right-of-way easement or permissions, in lieu of fee simple title, with respect to any portion of the Rights of Way) and shall be conveyed to “The South Carolina Department of Transportation” by general warranty deed, free and clear of all liens and encumbrances except permitted encumbrances.

11. Because these acquisitions are being made as agent on behalf of the State of South Carolina, SCDOT shall make the ultimate determination in each case as to whether settlement is appropriate or whether the filing of a condemnation action is necessary, taking into consideration the recommendations of the CONTRACTOR. When SCDOT authorizes the filing of a condemnation, CONTRACTOR shall prepare a Notice of Condemnation in the name of SCDOT, and submit it to SCDOT for SCDOT to file and serve appropriate condemnation documents and pleadings, and request priority status pursuant to S.C. Code Ann. Section 28-2-310(1976, as amended).

12. SCDOT shall prosecute condemnation proceedings to final judgment pursuant to the requirements of the South Carolina Eminent Domain Procedures Act. The procedure shall be by way of trial as provided by Section 28-2-240 of “The Act”. SCDOT shall be responsible for obtaining legal representation and CONTRACTOR will be responsible for providing expert witnesses necessary for condemnation actions. All settlements of condemnation cases shall be at SCDOT’s sole discretion.

13. CONTRACTOR will be responsible for all contacts with landowners for rights-of-way or construction items and shall provide the following:

- a) All Notices of Condemnation, issued pursuant to the authority granted, all titles of real estate and all right of way easements, permissions, or right-of easements, recorded with the Office of the Register of Deeds or the Clerk of Court for the county or counties in which properties acquired through condemnation are located;
- b) A right-of-way agent’s worksheet, or documents substantially in the format of SCDOT Form No. 809, for each tract.

14. CONTRACTOR shall provide a right-of-way certification and SCDOT shall approve that certification prior to CONTRACTOR entering the property. Only in exceptional circumstances will a certification be approved based on a right of entry. Certification may be on a tract-by-tract basis.

15. CONTRACTOR shall exercise care in its operations when working in proximity to adjacent developed properties, properties not yet acquired, and residences or

businesses that are to be relocated. CONTRACTOR shall submit a plan to the SCDOT's right-of-way representative for approval to:

- a) Establish a clear zone adjacent to properties occupied by persons to be displaced in which construction equipment may not be operated or parked,
- b) Establish a clear zone for construction for properties occupied by persons to be displaced to prevent undue impacts or hardships,
- c) Establish a method of protecting equipment from vandalism or unauthorized use,
- d) Locate brush piles and mulching/grinding operations more than 500 feet from an occupied business or residence, or as required by South Carolina Department of Health and Environmental Control burning regulations,
- e) Provide reasonable and safe access to residences or businesses that are to be displaced until such time as the property is vacant, and
- f) Observe the property rights of landowners of adjacent and/or yet to be acquired properties.

16. CONTRACTOR shall use reasonable care in determining whether there is reason to believe that property to be acquired for rights-of-way may contain concealed or hidden wastes or other materials or hazards requiring remedial action or treatment. When there is reason to believe that such materials may be present, CONTRACTOR shall take steps consistent with customary SCDOT practices to investigate. SCDOT shall be notified of the presence of such materials before an offer is made to acquire the property.

17. During the acquisition process and for a period of three years after final payment is made to CONTRACTOR for any phase of the work, all project documents and records not previously delivered to SCDOT, including but not limited to design and engineering costs, construction costs, costs of acquisition of rights-of-way, and all documents and records necessary to determine compliance with the laws relating to the acquisition of rights-of-way and the costs of relocation of utilities, shall be maintained and made available to SCDOT for inspection or audit.

B. Acquisition of Right-of-Way

1. The CONTRACTOR is responsible for verification of all information necessary for acquisition of the Right-of-Way and is responsible for all costs, excluding premium cost as defined below, associated with the purchase of the Right-of-Way. The CONTRACTOR shall acquire the property as an agent on behalf of the State of South Carolina.

2. Acquisition of any additional area desired by the CONTRACTOR necessary to complete the project, shall comply with this Article of the Contract, with the exception of cost allocation.

3. All costs associated with the acquisition of any additional area are the sole responsibility of the CONTRACTOR, including premium right-of-way costs. CONTRACTOR shall abide by the provisions of all applicable environmental permits, any conditions of individual right of way agreements, and all environmental commitments. Any necessary permit modifications are the responsibility of the CONTRACTOR.

4. Acquisition of any additional area desired by the CONTRACTOR for, but not limited to, construction staging, access or borrow pits shall be the sole responsibility of CONTRACTOR, and any title or interest shall be secured in the name of the CONTRACTOR. CONTRACTOR shall provide SCDOT the location and documentation for these additional areas. CONTRACTOR shall furnish SCDOT a copy of any agreements, whether for purchase or lease, for the use of additional properties in conjunction with the construction of the Project. CONTRACTOR shall abide by the provisions of all applicable environmental permits, any conditions of individual right of way agreements, and all environmental commitments. Any necessary permit modifications are the responsibility of the CONTRACTOR. CONTRACTOR is responsible for all costs associated with these additional areas, including premium right-of-way costs. If additional right-of-way is necessary beyond what has been evaluated in the NEPA documentation, CONTRACTOR shall be responsible for any re-evaluation of the approved Environmental Documents.

5. ROW acquisition costs shall be defined as amounts paid for: (1) direct payments for ownership or other property rights, and (2) direct payments for eligible relocation expenses as provided for under the Uniform Act less Premium ROW acquisition costs.

6. Premium ROW acquisition costs shall be the amount a jury award or a settlement that exceeds "Just compensation." "Just compensation" shall be defined as the value SCDOT approves for a parcel after the following procedure: CONTRACTOR shall submit its recommendation for just compensation based on appraisals and appraisal reviews which support the recommendation. If SCDOT approves CONTRACTOR'S recommendations, that value becomes just compensation. If SCDOT does not approve the recommendation, CONTRACTOR or SCDOT shall obtain another appraisal using an appraiser from the SCDOT's approved list and submit this appraisal to SCDOT. SCDOT shall be responsible for the cost of the second appraisal. SCDOT shall assign a value to the parcel which shall be deemed just compensation supported by the appraisals for the parcel.

7. CONTRACTOR shall be responsible for right-of-way service costs and right-of-way acquisition costs.

8. SCDOT shall be responsible for premium right-of-way costs except for those additional areas explained above.

9. Upon final completion of the project, if any right-of-way condemnation actions are still pending, CONTRACTOR shall provide reasonable and adequate security to cover its contractual obligation relating to right-of-way acquisition.

IX. PERMITS

A. All permits necessary for completion of this project shall be procured by the CONTRACTOR. The CONTRACTOR shall comply with all local, state, and federal permitting requirements. Regarding any permit or license that must be obtained in the name of SCDOT, the CONTRACTOR shall perform all functions within its power to obtain the permit or license, and SCDOT shall fully cooperate in this effort and perform any functions that must be performed by SCDOT. The CONTRACTOR shall submit permit applications to SCDOT. SCDOT will submit the permit application to the appropriate permitting agency indicating that CONTRACTOR is acting as an agent for SCDOT. If said regulatory agencies fail to issue permits in a timely manner, SCDOT may, on an individual basis, consider a time extension for permit approval delays when CONTRACTOR can demonstrate that the application was submitted in a timely manner, all reasonable efforts have been made to expedite the permit approval, and that the delay has a direct impact on the Critical Path. CONTRACTOR shall not be entitled to additional compensation for delays in permit approval.

B. All necessary permit modifications shall be the CONTRACTOR's responsibility. All work associated with permit modifications as a result of changes proposed by CONTRACTOR shall be CONTRACTOR's responsibility. See Article II.B.4 regarding deductions for waived fees.

X. ENVIRONMENTAL COMPLIANCE

A. Compliance with Environmental Commitments

CONTRACTOR shall comply with all Environmental commitments and requirements including, but not limited to, the following:

1. Compliance with the provisions of all environmental permits applicable to the Project. A copy of the environmental document is included in **Attachment B**. Environmental Commitments are included in **Exhibit 8**.

2. Compliance with those stipulations and conditions under which SCDOT received approval of the Environmental Document(s) and any modifications resulting from a re-evaluation of the Document(s). If the CONTRACTOR elects to construct the Project in a manner that is not consistent with the assumptions in the SCDOT prepared environmental documents, the CONTRACTOR will be responsible for revising the environmental documents and provide any additional studies that may be required. All

revisions will require SCDOT and FHWA approval prior to any right of way acquisition or construction activity;

3. Compliance with applicable laws and regulations relating to potential or actual hazardous materials that may be encountered in the course of carrying out this Agreement;

4. Carrying out all necessary social, economic, and environmental studies required by regulatory authorities in the course of construction;

5. Preparation of any permits required by federal, state, or local laws or regulations; The CONTRACTOR is responsible for any mitigation required by permits; and

6. The resolution of any deviations from the contract documents, drawings or other information included in the environmental permits that would violate the intent or spirit of the permits. Any proposed changes within the permitted areas would need to be coordinated with SCDOT's Environmental Management Office.

B. Preconstruction / Partnering Conference(s)

CONTRACTOR shall conduct one (or more, if appropriate) pre-construction / partnering conference(s) prior to any construction activity to discuss environmental and permitting issues, which conference shall include all subcontractors, and, to the extent feasible, representatives from the U.S. Army Corps of Engineers, the S.C. Department of Health and Environmental Control Water Quality Division, the Federal Highway Administration, CONTRACTOR, and SCDOT.

C. Protection of Archeological and Paleontological Remains and Materials

1. When archeological or paleontological remains are uncovered, CONTRACTOR shall immediately halt operations in the area of the discovery and notify SCDOT.

2. Archeological remains consist of any materials made or altered by man which remains from past historic or prehistoric times (i.e. older than 50 years) Examples include old pottery fragments, metal, wood, arrowheads, stone implements or tools, human burials, historic docks, structures or not recent (i.e. older than 100 years) vessel ruins. Paleontological remains consist of old animal remains, original or fossilized, such as teeth, tusks, bone, or entire skeletons.

3. SCDOT will have the authority to suspend the work for the purpose of preserving, documenting, and recovering the remains and materials of archeological and paleontological importance for the State. CONTRACTOR shall carry out all instructions of SCDOT for the protection of archeological or paleontological remains, including steps to protect the site from vandalism and unauthorized investigations, from accidental damage and from dangers such as heavy rainfall or runoff.

4. CONTRACTOR's Contract Time and or Contract Price shall be adjusted to the extent CONTRACTOR's cost and /or time of performance have been adversely impacted by the presence of archeological or paleontological remains.

XI. HAZARDOUS MATERIALS

A. CONTRACTOR is responsible for obtaining any necessary survey(s) to determine the extent of and develop a remedial strategy of Hazardous materials, wastes, substances or chemicals on the Project. The cost of the surveys shall be included in the Contract Price. The CONTRACTOR shall anticipate that the structural steel components contain lead-based paints. The CONTRACTOR shall remove and dispose of the structural steel components containing lead-based paints in compliance with all applicable Federal (EPA, OSHA & DOT) and State requirements for lead as waste, lead in air, lead in water, lead in soil, and worker health and safety. The cost the removal and disposal of components containing lead-based paints shall be included in the Contract Price. The CONTRACTOR is required to perform asbestos inspections on the existing structures. A copy of the asbestos report and a notification of demolition or renovation forms must be submitted to the South Carolina Department of Health and Environmental Control at least ten (10) working days prior to demolition of an existing structure. The CONTRACTOR is responsible for obtaining all required permits to proceed with the work. The CONTRACTOR is responsible for required containment and disposal of the asbestos. The cost of removal and disposal of components containing asbestos shall be included in the Contract Price.

B. A Hazardous Material/Waste Assessment and Phase II Limited Subsurface Assessment were complete for the project area in 2005 by ARM Environmental Services. These reports are provided in Attachment B. The Phase II report, dated June 30, 2005 identified five properties that may contain hazardous materials and or underground storage tanks – Pantry #879, Detyen's Shipyard, Wando Grocery, SCDOT Section Shed, and Cohen Gaskins Jr. Property. Additional surveys to determine the applicability of remediation and or remedial strategy for these sites shall be the responsibility of the CONTRACTOR. Any remediation necessary to rectify these sites shall be included as part of the project. The cost of the additional surveys and any remediation efforts to remove the hazardous materials and/or underground storage tanks shall be included in the Contract Price. All necessary permitting shall comply with Articles II.B.4 of the Contract. A copy of the survey report and a notification of demolition or renovation forms must be submitted to the South Carolina Department of Health and Environmental Control at least ten (10) working days prior to removal of any existing structures.

C. Except as noted in paragraph "A" and "B" above, CONTRACTOR is not responsible for handling, storage, remediation, or disposal of any materials, wastes, substances and chemicals deemed to be hazardous under applicable state or federal law, (hereinafter "Hazardous Conditions") encountered at the Site which were not introduced to the site by CONTRACTOR or any of its agents. Upon encountering any Hazardous Conditions, CONTRACTOR shall stop Work immediately in the affected area and duly notify SCDOT and,

if required by state or federal law, all government or quasi-government entities with jurisdiction over the Project or site.

D. Upon receiving notice of the presence of Hazardous Conditions, SCDOT will take necessary measures required to ensure that the Hazardous Conditions are remediated or rendered harmless. Such necessary measures will include SCDOT either (i) retaining qualified independent firm or (ii) negotiating a construction change directive with CONTRACTOR.

E. CONTRACTOR shall resume Work at the affected area of the Project only after written notice from SCDOT that the (i) Hazardous Conditions have been removed or rendered harmless and (ii) all necessary approvals have been obtained from all government and quasi-government entities having jurisdiction over the Project.

F. CONTRACTOR's Contract Price and/or Contract Time shall be adjusted to the extent CONTRACTOR's cost and/or time of performance has been adversely impacted by the presence of Hazardous Conditions.

G. SCDOT is not responsible for Hazardous Conditions actually brought to the Project by CONTRACTOR, CONTRACTOR's design consultants, subcontractors and suppliers or anyone for whose acts they may be or are liable. SCDOT is not responsible for negligent or willful acts by CONTRACTOR, CONTRACTOR's design consultants, subcontractors and suppliers or anyone for whose acts they may be or are liable relating to Hazardous Conditions found at the site. CONTRACTOR shall indemnify, defend and hold harmless SCDOT and SCDOT's officers, directors, employees and agents from and against all claims, losses, damages, liabilities and expenses, including attorney's fees and expenses arising out of or resulting solely from those Hazardous Conditions actually brought to the Project or negligent or willful acts relating to Hazardous Conditions, or both by CONTRACTOR, CONTRACTOR's design consultants, subcontractors and suppliers or anyone for whose acts they may be or are liable.

XII. DEMOLITION, REMOVAL & DISPOSAL OF STRUCTURES

CONTRACTOR shall be responsible for the demolition, removal and disposal of all structures and their appurtenances within SCDOT Right of Way necessary for the completion of the Project, to include those portions which may extend outside the right of way, but were purchased as a part of the acquisition process. Structures shall include the bridges identified in the scope of work, ~~all foundations from previous bridges as set forth in the Scope of Work,~~ and all buildings acquired for the Project. All necessary permitting shall comply with Articles II.B.4 and IX of the Contract. Handling and disposal of Hazardous Material shall be in accordance with Article XI of the Contract. Before demolition of the ~~bridge~~ structures, the CONTRACTOR shall complete and submit a Notification of Demolition and Renovation form to the South Carolina Department of Health and Environmental Control.

XIII. DIFFERING SITE CONDITIONS

A. "Differing Site Conditions" are defined as concealed or latent physical conditions at the Site that (i) materially differ from the conditions reasonably assumed to exist based on the information contained in the RFP, this Agreement and its Exhibits; or (ii) are of an unusual

nature, differing materially from the conditions ordinarily encountered and generally recognized as inherent in the work. For this project, subsurface/geotechnical conditions WILL NOT be considered as a Differing Site Condition.

B. Upon encountering a Differing Site Condition, CONTRACTOR shall provide prompt written notice to SCDOT of such condition, which notice shall not be later than twenty (20) days after such condition has been encountered. CONTRACTOR shall provide such notice before the Differing Site Condition has been substantially disturbed or altered and before any work is performed.

C. Upon written notification, SCDOT will investigate the conditions and if it is determined that the conditions differ materially and cause an increase or decrease in the cost or time required for performance of the work, the Contract will be adjusted. No contract adjustment that results in a benefit to CONTRACTOR will be allowed unless CONTRACTOR has provided the required written notice.

XIV. FORCE MAJEURE

Delays or failures of performance shall not constitute breach of the Agreement if and to the extent such delays or failures of performance are caused by severe and not reasonably foreseeable occurrences beyond the control of SCDOT or CONTRACTOR, including, but not limited to: Acts of God or the public enemy; expropriation or confiscation of facilities; compliance with any order or request of any governmental authority other than SCDOT or a party in privity with it; a change in law directly and substantially affecting performance of the Project; Acts of War; rebellion or sabotage or damages resulting there from; fires, floods, explosions, or extraordinary accidents; riots or strikes or other concerted acts of workman, whether direct or indirect, or any similar causes, which are not within the control of SCDOT or CONTRACTOR respectively, and which by the exercise of reasonable diligence, SCDOT or CONTRACTOR are unable to prevent. Any expense attributable to such occurrence shall not entitle CONTRACTOR to an adjustment in the Contract Price. Any critical path delay attributable to such an occurrence shall be added to the Contract Time.

XV. WARRANTY

A. CONTRACTOR warrants that it will perform all services in accordance with the standards of care and diligence normally practiced by recognized engineering and construction firms in performing services and obligations of a similar nature. CONTRACTOR warrants that all materials and equipment furnished shall be of good quality and new unless otherwise authorized by SCDOT and that the construction shall conform to the Contract requirements. CONTRACTOR agrees to promptly correct, at its own expense, defects or deficiencies in materials and workmanship that appear prior to and during a period of three (3) years after Final Completion of the Project. This shall include all plant-produced materials (i.e. asphalt, concrete, etc.). CONTRACTOR shall not be responsible for damages caused by SCDOT's failure to provide timely notification of potentially damaged or defective work of which SCDOT had actual knowledge. CONTRACTOR shall properly perform, at the written request of SCDOT

made at any time within the warranty period after Final Completion of the Project as defined in Article IV.A.5, all steps necessary to satisfy the foregoing warranty and correct any element of the Project or the services that is defective or does not reflect such standards of care and diligence. The cost of such corrective services shall be CONTRACTOR's responsibility.

B. CONTRACTOR further warrants the performance of all bridge components on all structures for three (3) years from Final Completion of the Project. If a component fails to perform properly for any reason, including but not limited to normal wear and tear, the CONTRACTOR shall replace the failed component at no cost to SCDOT.

C. The warranty periods begin at Final Completion of the Project. CONTRACTOR shall immediately abate any warranty deficiency that poses an unsafe condition to the public; otherwise deficiencies shall be corrected no later than 30 days from the determination of corrective action. In the event CONTRACTOR, after notice, fails to immediately abate the deficiency or fails to make correction within the prescribed thirty (30) days, SCDOT may have the deficiency corrected. All costs associated with such correction by SCDOT shall be the responsibility of the CONTRACTOR and his Surety. With respect to any component that is repaired or replaced pursuant to this warranty, the warranty period of that component shall be the longer of one year from repair or replacement of the component or the remainder of the original warranty period.

D. CONTRACTOR shall take all steps necessary to transfer to SCDOT any manufacturer's or other third-party's warranties of any materials or other services used in the construction of the Project.

XVI. INDEMNITY

A. CONTRACTOR shall indemnify, defend and hold SCDOT harmless from any and all claims, liabilities and causes of action for any fines or penalties imposed on SCDOT by any state or federal agency because of violation by CONTRACTOR or any of its subcontractors of any state or federal law or regulation.

B. CONTRACTOR shall indemnify, defend and hold SCDOT harmless from any and all claims, liabilities and causes of action arising out of or resulting from, in whole or in part, the negligence or recklessness of CONTRACTOR or its agents, consultants and/or subcontractors.

XVII. TERMINATION AND CANCELLATION

A. Termination for Default

1. CONTRACTOR shall be in default of the Contract if it:

- a) Fails to supply a sufficient number of properly skilled workmen, tools, materials and equipment to assure the prompt completion of the work;

- b) Fails to perform work in accordance with contract requirements and/or refuses to remove or replace rejected materials or unacceptable work;
- c) Discontinues the prosecution of the work;
- d) Fails to resume work that has been discontinued within a reasonable time after notice to do so;
- e) Becomes insolvent or is declared bankrupt or commits any act of bankruptcy or insolvency;
- f) Allows any final judgment to remain unsatisfied for a period of 15 days;
- g) Makes an assignment for the benefit of creditors;
- h) Fails to maintain the Project schedule;
- i) Commits a substantial breach of the Contract; or
- j) For any other cause whatsoever, fails to carry on the work in an acceptable manner.

2. If CONTRACTOR does not commence work to cure the default within 15 days after receipt of written notice from SCDOT and thereafter diligently prosecute work to completion within a reasonable time as determined by SCDOT, then SCDOT will have full power and authority to terminate CONTRACTOR for default and shall provide written notification of the termination to CONTRACTOR and Surety.

3. Upon termination for default, Surety will have the right to complete the contract and shall be given thirty (30) days, or longer in SCDOT's discretion, in which to resume the work. This procedure shall not in any way serve to extend the contract time. All charges incident to negotiation with the Surety and arranging for work to be resumed, including attorney's fees, shall be charged against CONTRACTOR or Surety as part of the cost of the work.

4. If Surety refuses to complete the work or fails to take over the work promptly as provided by this Agreement, then SCDOT may appropriate or use any or all materials and equipment on the job site as may be suitable and acceptable and may enter into an agreement for the completion of the Contract. All costs and charges incurred by SCDOT together with the cost of completing the work under the Contract will be deducted from any monies due or which may become due CONTRACTOR. If such expense exceeds the sum which would have been payable under the Contract, CONTRACTOR and Surety shall be liable and shall pay to SCDOT the amount of such excess.

5. Upon termination for default, all Project Documents, as defined in Article II.E, shall be surrendered forthwith by CONTRACTOR to SCDOT. SCDOT will be

authorized to use the Project documents for the sole purpose of promoting, completing, using, maintaining, upgrading or adding to the Project. This authorization includes allowing design professionals to make changes, corrections, or additions to the Project documents for these purposes.

6. If, after termination, it is determined that the Contractor was not in default, or that the default was excusable, the rights and obligations of the parties shall be the same as if the termination had been issued for the convenience of the State.

B. Termination for Convenience

1. SCDOT reserves the right to cancel the Work upon ten (10) days written notice to CONTRACTOR. Should the Work be so canceled by SCDOT for convenience, CONTRACTOR shall be paid for the value of the Work, based upon the Schedule of Values, performed to the date of cancellation and demobilization together with any cancellation charges by vendors and subcontractors. CONTRACTOR shall also be entitled to the cost of securing the work, provided such cost is approved by SCDOT. In no event, however, shall the total payment to CONTRACTOR pursuant to such a cancellation exceed the Contract Price.

2. Termination of all or a portion of the Contract shall not relieve CONTRACTOR of any responsibility it would otherwise have for the work completed, or for any claims arising from that work.

3. Upon such termination, all Project Documents, as defined in Article II.E, shall be surrendered forthwith by CONTRACTOR to SCDOT. SCDOT will be authorized to use the Project documents for the sole purpose of promoting, completing, using, maintaining, upgrading or adding to the Project. This authorization includes allowing design professionals to make changes, corrections, or additions to the Project documents for these purposes.

XVIII. DISADVANTAGED BUSINESS ENTERPRISES

A. DBE Goal - The DBE goal on this Project is seven and one-half percent (7.5 %) of the Contract Price. CONTRACTOR shall comply with the requirements of the Instructions to Proposers - DBE Requirements and the Supplemental Specifications entitled "Disadvantaged Business Enterprises (DBE) – Federal Projects" attached hereto as **EXHIBIT 7**. CONTRACTOR shall be responsible for ensuring that the DBE's listed on the committal sheet perform the items of work for which they are listed in accordance with the requirements of 49 CFR Part 26.

B. Copies of DBE Contracts - CONTRACTOR shall provide SCDOT with copies of executed DBE contracts, including the name of the DBE firm, the name of the subcontractor, if any, for whom the DBE will work, the amount of the contract, the type of work to be performed, and an estimated schedule of DBE performance.

C. Monthly Subcontractor Expenditure Records - CONTRACTOR shall provide SCDOT a monthly report showing amounts paid to subcontractors on the Project. The report shall provide a running total of amounts paid to subcontractors on the Project, including the name of each subcontractor paid, the amount paid to each in that month, and the cumulative amount paid to each as of the date of the report. The report shall also indicate whether the subcontractor is a DBE or non-DBE firm.

D. SCDOT'S Right to Audit - SCDOT will have the right to audit all documentation regarding DBE participation in the Project.

E. Nondiscrimination - CONTRACTOR, or subcontractor, shall not discriminate on the basis of race, color, national origin, or sex in the performance of this contract. CONTRACTOR shall carry out applicable requirements of 49 CFR Part 26 in the award and administration of SCDOT assisted contracts. Failure by CONTRACTOR to carry out these requirements is a material breach of this contract, which may result in the termination of this contract or such other remedy, as SCDOT deems appropriate.

XIX. ON-THE-JOB TRAINING REQUIREMENTS

There is an On-The-Job Training Requirement for this Project. The number of persons to be trained under the On-the-Job Training Program during this Project is six (6) for Bridge. The CONTRACTOR shall comply with the requirements of the Federal-Aid Project Supplemental Specifications attached hereto as **EXHIBIT 7**. The CONTRACTOR shall submit its plan for On-the-Job Training to SCDOT for written approval prior to commencing construction activities.

XX. RECORD RETENTION

A. CONTRACTOR shall maintain the following documents for a period of three (3) years after Final Completion of the Project:

1. All CONTRACTOR samples and test reports;
2. Daily Diaries (substantially in the form of SCDOT's form 647, as revised 7/95);
3. Any other documents required to be retained in accordance with the Quality Control Plan.

B. During the three (3) year retention period, SCDOT will be granted access to those documents upon reasonable notice. At any time during the three (3) year period, SCDOT will have the option of taking custody of the documents. CONTRACTOR shall obtain a written release from SCDOT prior to destroying the records after the three (3) year retention period.

XXI. AS-BUILTS

A. In addition to those documents set forth elsewhere in this Agreement, CONTRACTOR shall provide to SCDOT prior to Final Completion, complete sets of as-built drawings (See Article XXI.D for details). As-built plans consist of the final version of the design plan CADD drawings that incorporate all changes, including any adjustments, relocations, additions and deletions that occurred during construction. CONTRACTOR shall certify that the as-built plans are a true and correct representation of the work as constructed.

B. Information regarding major revisions to the plans shall be noted in a revision box on the plans. The information listed in the revision box shall include: the initiator of the revision, a brief explanation of the nature of the revision, and acceptance and approval from CONTRACTOR, along with associated dates.

C. In addition to the revisions that incorporated changes during construction, the as-built plans shall include the following information gathered during construction:

1. The location and elevation of foundations remaining below grade.
2. The final profile of each bridge constructed. The profile shall include the elevation along the centerline (or as specified by SCDOT) and a line three feet inboard of each gutter line. Points on the profile shall be taken at no greater than 25-foot intervals and shall include the beginning and end of each span.
3. If any structure has pile foundations, information concerning the pile driving operation shall be listed to include pile and driving equipment data, final pile bearing, elevation of pile tip when plan bearing was obtained, final pile tip elevation, penetration into the ground, and PDA or WEAP analysis data. This information shall be entered on each footing or bent sheet, or be included as a new sheet inserted immediately following the pertinent footing or bent sheet.
4. If any structure has drilled shaft foundations, information concerning the installation of the shaft shall be listed to include the drilled shaft report. This information shall be entered on each footing or bent sheet, or be included as a new sheet inserted immediately following the pertinent footing or bent sheet.
5. The final horizontal location of all existing and relocated utility lines and structures that are within the right-of-way.
6. The final location of all pipes, culverts, and drainage structures.
7. To include all right-of-way revisions, permissions, and an updated right-of-way data sheet to show the date and manner of acquisition of each tract

D. As-built plans shall be submitted as two (2) full size (36 inch x 22 inch) copies and one (1) copy on compact disc in a format acceptable to SCDOT. The levels and symbology of the as-built CADD drawings shall conform to SCDOT standard levels and symbology used to develop the design drawings for the Project.

XXII. ESCROW PROPOSAL DOCUMENTS

A. Scope and Purpose

The purpose of this article is to preserve the proposal documents of the successful proposer (CONTRACTOR) for use by the parties in any claims or litigation between SCDOT and CONTRACTOR arising out of this contract.

CONTRACTOR shall submit a legible copy of proposal documentation used to prepare the Technical and Cost Proposal for this contract to SCDOT. Such documentation shall be placed in escrow with a banking institution or other bonded document storage facility and preserved by that institution/facility as specified in the following sections of this specification.

B. Proposal Documentation

The term "proposal documentation" as used in this specification means all writings, working papers, computer print outs, charts, and all other data compilations which contain or reflect information, data, and calculations used by CONTRACTOR to prepare the technical and cost proposal in proposing for the Project. The term "proposal documentation" includes, but is not limited to, equipment rates, overhead rates, labor rates, efficiency or productivity factors, arithmetic extensions, and quotations from subcontractors and material suppliers to the extent that such rates and quotations were used by CONTRACTOR in preparing, formulating and determining the technical and cost proposal. The term "proposal documentation" also includes any manuals that are standard to the industry used by CONTRACTOR in determining the proposal for the Project. Such manuals may be included in the proposal documentation by reference. Such reference shall include the name and date of the Publication and the Publisher. The term does not include proposal documents provided by SCDOT for use by CONTRACTOR in proposing on the Project.

C. Submittal of Proposal Documentation

CONTRACTOR shall submit the proposal documentation to SCDOT, in a container suitable for sealing, no later than ten calendar days following award of the Contract by SCDOT. CONTRACTOR will not be allowed to begin work until the acceptable documentation has been received. The container shall be clearly marked "Proposal Documentation" and shall also show on the face of the container CONTRACTOR's name, the date of submittal, the File Number, and the Project Name.

D. Alternative Delivery Method

CONTRACTOR may elect to use a delivery service to escrow the proposal documents directly with the escrow agent/facility as required under this Article. A delivery service with a tracking system such as FedEx, UPS, or DHL shall be used by the CONTRACTOR under this method of delivery. To affect delivery, CONTRACTOR is required to comply with the delivery procedures set forth under special provision entitled *Procedures to Escrow Bid Documentation by Delivery Service*, dated November 17, 2005, attached hereto as **EXHIBIT 9**. For purposes of this Agreement, the term bid documentation used in the special provision has the same meaning as proposal documentation in Section B above.

E. Affidavit

In addition to the proposal documentation, an affidavit, signed under oath by an individual authorized by CONTRACTOR to execute contracts shall be included. The affidavit shall list each proposal document with sufficient specificity so a comparison may be made between the list and the proposal documentation to ensure that all of the proposal documentation listed in the affidavit has been enclosed. The affidavit shall attest the following:

1. The affiant has personally examined the proposal documentation,
2. The affidavit lists all of the documents used by CONTRACTOR to determine the proposal for the Project, and
3. All such proposal documentation has been included.

F. Verification

Upon receipt of the proposal documentation, authorized representatives of SCDOT and CONTRACTOR will verify the accuracy and completeness of the proposal documentation compared to the affidavit. Should a discrepancy exist, CONTRACTOR shall immediately furnish SCDOT with any other needed proposal documentation. SCDOT, upon determining that the proposal documentation is complete, will, in the presence of CONTRACTOR's representative, immediately place the complete documentation and affidavit in the container and seal it. Both parties will deliver the sealed container to a banking institution or other bonded document storage facility selected by SCDOT for placement in a safety deposit box, vault or other secure accommodation.

G. Duration and Use

The proposal documentation and affidavit shall remain in escrow during the life of the Contract or until such time as CONTRACTOR files a claim or initiates litigation against SCDOT related to the contract. Receipt of CONTRACTOR's claim, or litigation against SCDOT, shall be sufficient evidence for SCDOT to obtain the release and custody of the proposal documentation. If no such claim is received or litigation initiated, the Final Estimate has been paid and the warranty period for the Contract has expired, SCDOT shall instruct the banking institution or other bonded document storage facility to release the sealed container to CONTRACTOR using the form provided in **EXHIBIT 9**.

CONTRACTOR agrees that the sealed container placed in escrow contains all of the proposal documentation used to determine the proposal and that no other proposal documentation shall be utilized by CONTRACTOR in litigation over claims brought by CONTRACTOR arising out of this contract.

H. Refusal or Failure to Provide Proposal Documentation

Refusal of CONTRACTOR to provide adequate documentation will be considered material breach of the Contract and CONTRACTOR will be declared in default of the

Contract. SCDOT may, at its option, terminate the contract for default. These remedies are not exclusive and SCDOT may take such other action as is available to it under the law.

I. Confidentiality of Bid Documentation

The proposal documentation and affidavit in escrow are, and will remain, the property of CONTRACTOR. SCDOT has no interest in, or right to, the proposal documentation and affidavit other than to verify the contents and legibility of the proposal documentation unless a claim is received or litigation ensues between SCDOT and CONTRACTOR. In the event of such claim or litigation, the proposal documentation and affidavit shall become the property of SCDOT.

J. Cost and Escrow Instructions

The cost of escrow will be borne by SCDOT. SCDOT will provide escrow instructions to the banking institution or other bonded document storage facility consistent with this article.

K. Escrow Agreement

CONTRACTOR agrees that it will sign an Escrow Agreement with SCDOT and the escrow agent consistent with this article. Should CONTRACTOR fail to sign the Escrow Agreement, when presented, CONTRACTOR may be declared in default of the Contract. The Escrow Agreement is attached in **EXHIBIT 9**.

L. Payment

There will be no separate payment for compilation of the data, container or cost of verification of the proposal documentation. All cost shall be included in the overall Contract Price.

XXIII. DISPUTE RESOLUTION

A. Each party hereby waives a trial by jury regarding any dispute between them arising out of this Contract and any such trial will be a non-jury trial before the South Carolina Circuit Court.

B. In the event of a dispute between the parties, it shall be a condition precedent to litigation that the parties submit the dispute to the Standing Dispute Review Board pursuant to the Claims Procedure set forth in the Project Supplemental Specifications.

C. CONTRACTOR consents that any papers, notices, or process necessary or proper for the initiation or continuation of any disputes, claims, or controversies relating to the Agreement; for any court action in connection therewith; or for the entry of judgment on any award made, may be served on CONTRACTOR by certified mail (return receipt requested) addressed to CONTRACTOR at the address provided in Article XXVI. Notice by certified mail is deemed duly given upon deposit in the United States mail.

XXIV. SCDOT'S AGENT

SCDOT will appoint an individual who will be authorized to act on behalf of SCDOT, with whom CONTRACTOR may consult at all reasonable times, and whose instructions and decisions will be binding upon SCDOT as to all matters pertaining to this Agreement and the performance of the parties hereunder.

XXV. ASSIGNABILITY

The Contract shall not be assignable by CONTRACTOR without the prior written consent of SCDOT. SCDOT may assign the Contract without the consent of CONTRACTOR.

XXVI. GENERAL PROVISIONS

A. This Agreement shall be governed by and interpreted in accordance with the substantive laws of the State of South Carolina.

B. Headings and titles of the various parts of this Agreement are for convenience of reference only and shall not be considered in interpreting the text of this Agreement. Modifications or amendments to this Agreement must be in writing and executed by duly authorized representatives of each party.

C. In the event that any portion or all of this Agreement is held to be void or unenforceable, the parties agree to negotiate in good faith to reach an equitable agreement which shall affect the intent of the parties as set forth in this Agreement.

D. All notices pertaining to this Agreement shall be in writing and, if to SCDOT, will be sufficient when sent registered or certified mail to SCDOT addressed as follows:

Deputy Secretary for Engineering
South Carolina Department of Transportation
Post Office Box 191
Columbia, South Carolina 29202-0191

All notices to CONTRACTOR shall be sufficient when sent registered or certified mail to CONTRACTOR addressed as follows:

(Insert CONTRACTOR'S address here)

E. The Contract Documents set forth the full and complete understanding of the parties as of the Effective Date defined herein, and supersedes any and all agreements and representations made or dated prior thereto.

F. The parties make no representations, covenants, warranties or guarantees, express or implied, other than those expressly set forth herein. The parties' rights, liabilities, responsibilities and remedies within respect to the work shall be exclusively those expressly set forth in this Agreement.

G. In no event shall any failure by either party hereto to fully enforce any provision to this Agreement be construed as a waiver by such party of its right to subsequently enforce, assert or rely upon such provision.

H. Nothing in this Agreement is intended to create any contract rights for any party other than SCDOT and CONTRACTOR, nor are any third-party beneficiary rights intended to be created hereby.

Agreement for SC Route 41 Bridge Replacement over the Wando River
Berkeley and Charleston Counties

IN WITNESS WHEREOF, the parties hereto have executed this Agreement as of the Effective Date defined herein. The Effective Date is defined as the date signed by the Director of Construction on behalf of South Carolina Department of Transportation.

Witnesses:

Date: _____

Witnesses:

SOUTH CAROLINA DEPARTMENT
OF TRANSPORTATION

By: _____
Leland D. Colvin, P.E.
Director of Construction

Recommended:

Greg Peck
Contract Administrator

CONTRACTOR

Name of Contractor

By: _____

Its: _____

CERTIFICATION OF CONTRACTOR

I hereby certify that I am the duly authorized representative of CONTRACTOR and that neither I nor the above CONTRACTOR I here represent has:

- a) employed or retained for a commission, percentage, brokerage, contingent fee, or other consideration, any firm or person (other than a bona fide employee working solely for me or the above CONTRACTOR) to solicit or secure this contract;
- b) agreed, as an express or implied condition for obtaining this contract, to employ or retain the services of any firm or person in connection with carrying out the contract, or
- c) paid, or agreed to pay, to any firm, organization or person (other than a bona fide employee working solely for me or the above CONTRACTOR) any fee, contribution, donation, or consideration of any kind for, or in connection with, procuring or carrying out the contract except as here expressly stated (if any);
- d) either directly or indirectly, entered into any agreement, participated in any collusion, or otherwise taken any action, in restraint of free competitive bidding in connection with the submitted proposal.

By execution of this Agreement, CONTRACTOR certifies CONTRACTOR and all CONTRACTOR's consultants, sub-consultants, contractors, employees and agents will comply with South Carolina's Ethics, Government Accountability, and Campaign Reform Act of 1991, as amended. The following statutes require special attention: (a) Offering, giving, soliciting, or receiving anything of value to influence action of public employee - §8-13-790, 8-13-705, 8-13-720; (b) Recovery of kickbacks - §8-13-790, (c) Offering, soliciting or recovering money for advice or assistance of public official - §8-13-720, (d) Use or disclosure of confidential information - §8-13-725, (e) Persons hired to assist in the preparation of specifications or evaluation of bids - §8-13-1150, (f) Solicitation of state employees - §8-13-755, 8-13-760 and §8-13-725, (g) False Claims Act -§16-13-240. The state may rescind any contract and recover all amounts expended as a result of any action taken in violation of this provision.

I acknowledge that this certificate is to be furnished to the Department, the Federal Highway Administration, and the U. S. Department of Transportation, and is subject to applicable State and Federal laws, both criminal and civil.

I acknowledge that giving false, misleading, or incomplete information on this certification may subject me to prosecution under Section 16-9-10 of the South Carolina Code of Laws.

CONTRACTOR

Name of Contractor

By: _____

Date: _____

Its: _____

CERTIFICATION OF DEPARTMENT

I hereby certify that I am the Director of Construction for the South Carolina Department of Transportation (SCDOT) of the State of South Carolina and that the above CONTRACTOR or its representative has not been required, directly or indirectly, as an express or implied condition in connection with obtaining or carrying out this agreement to:

- (a) employ or retain, or agree to employ or retain, any firm or person, or
- (b) pay, or agree to pay, to any firm, person, or organization, any fee, contributions, donations, or consideration of any kind, except as here expressly stated (if any).

I acknowledge that this certificate is to be furnished to the Federal Highway Administration, and U. S. Department of Transportation, and is subject to applicable State and Federal laws, both criminal and civil.

SOUTH CAROLINA DEPARTMENT OF
TRANSPORTATION

BY: _____

TITLE: DIRECTOR OF CONSTRUCTION

Date: _____

DRUG-FREE WORKPLACE CERTIFICATION

In accordance with Section 44-107-30, South Carolina Code of Laws (1976), as amended, and as a condition precedent to the execution of this agreement, the undersigned, who is an authorized representative of the PROPOSER certifies on behalf of the PROPOSER that the PROPOSER will provide a drug-free workplace by:

- (1) publishing a statement notifying employees that the unlawful manufacture, distribution, dispensations, possession, or use of a controlled substance is prohibited in the PROPOSER's workplace and specifying the actions that will be taken against employees for violations of the prohibition;
- (2) establishing a drug-free awareness program to inform employees about:
 - (a) the dangers of drug abuse in a workplace;
 - (b) the person's policy of maintaining a drug-free workplace;
 - (c) any available drug counseling, rehabilitation, and employee assistance programs; and
 - (d) the penalties that may be imposed upon employees for drug violations;
- (3) making it a requirement that each employee to be engaged in the performance of the agreement be given a copy of the statement required by item (1);
- (4) notifying the employee in the statement required by item (1) that, as a condition of employment of this agreement, the employee will:
 - (a) abide by the terms of the statement; and
 - (b) notify the employer of any criminal drug statute conviction for a violation occurring in the workplace no later than five days after the conviction;
- (5) notifying the South Carolina Department of Transportation within ten days after receiving notice under item (4)(b) from an employee or otherwise receiving actual notice of the conviction;
- (6) imposing a sanction on, or requiring the satisfactory participation in a drug abuse assistance or rehabilitation program by, any employee convicted as required in Section 44-107-50; and
- (7) making a good faith effort to continue to maintain a drug-free workplace through implementation of items (1), (2), (3), (4), (5), and (6)

By execution of this Agreement PROPOSER certifies PROPOSER and all PROPOSER's consultants, sub-consultants, contractors, employees and agents will comply with all applicable provisions of the Drug-Free Workplace Act, Title 44, Chapter 107 of the South Carolina Code of Laws, as amended.

PROPOSER: _____
(Signature)

EXHIBIT 1

COST PROPOSAL BID FORM

PROPOSED COST PROPOSAL BID FORM
FOR
REPLACEMENT OF SC 41 BRIDGE OVER THE WANDO RIVER
CHARLESTON AND BERKELEY COUNTIES

The *Cost Proposal Bid Form*, as submitted by the selected PROPOSER, will be included with the completed agreement.

EXHIBIT 2

SCHEDULE OF VALUES

SCHEDULE OF VALUES
FOR
REPLACEMENT OF SC 41 BRIDGE OVER THE WANDO RIVER
CHARLESTON AND BERKELEY COUNTIES

A Schedule of Values, submitted by the selected PROPOSER and approved by SCDOT, will be included with the completed agreement.

EXHIBIT 3

SCOPE OF WORK

SCOPE OF WORK

General

The CONTRACTOR is to perform, at a minimum, all work necessary to complete the replacement of the SC 41 Bridge over the Wando River as described within this Scope of Work, the Contract Agreement, and the Request for Proposals (RFP). This work shall be performed in accordance with all contract requirements. In carrying out this work, the CONTRACTOR is responsible for all contract services including, but not limited to, project administration, design, plan preparation services (including traffic signal design), demolition and construction services for roadway and bridge, maintenance of traffic, any necessary right of way acquisitions and acquisition services, utility coordination and relocation services, contractor quality control, environmental permits, preparation of as-built plans, public/community relations, and any other service that may be necessary for the replacement of the bridge.

As part of the design services, the CONTRACTOR shall complete the design throughout the project limits per the typical sections provided **and according to the details contained herein**. The CONTRACTOR is fully responsible for compliance with the specifications and standards cited in all Contract Documents. Design submittals shall be provided in accordance with the Contract Agreement. Any deviation from the proposed design (whether necessary or desired by the CONTRACTOR) shall meet or exceed the contract requirements. If the project design necessitates a modification to any previously approved document (including but not limited to, the environmental document), the CONTRACTOR is responsible for the necessary studies and reports. Final review and approval lies with SCDOT and FHWA.

Acquisition and all costs associated with acquiring the necessary right-of-way shall be the responsibility of the CONTRACTOR. If additional right-of-way is required outside of the NEPA footprint, it shall be the responsibility of the CONTRACTOR to provide a re-evaluation of the NEPA document and to revise any permits deemed necessary to reflect the proposed right-of-way.

Project Summary

The project consists of replacing the existing SC Route 41 moveable-span bridge over the Wando River in Berkeley and Charleston Counties, South Carolina with a fixed-span bridge with 55 feet of vertical clearance. The limits of the project extend from approximately Harpers Ferry Way north across the Wando River, then along a portion of Clements Ferry Road to the intersection with Reflectance Road. The project includes the realignment of the intersection of SC 41 and Clements Ferry Road and the installation of a stop and go traffic signal.

The Scope of Work includes all services necessary to design, acquire necessary right-of-way and construct the bridge and associated roadway approaches complete and open to traffic, and demolish and dispose of existing bridge. **The CONTRACTOR will be required to demonstrate that substructures of existing structures have been removed as required in Section 202.4.2 of SCDOT's 2007 Standard Specifications for Highway Construction.** In addition, the scope

includes the demolition and stabilization of the abandoned portions of SC 41 and Clements Ferry Road with exception to those portions required for property access.

The CONTRACTOR shall construct the new bridge structure on the upstream side of the existing bridge within the National Environmental Policy Act (NEPA) Footprint as shown in the Environmental Assessment and Public Meeting Displays in Attachment B. The CONTRACTOR shall not impact the steel utility support and foundation (approximately Latitude 32°55'24.15"N, Longitude 79°49'24.62"W) and overhead transmission lines that cross the Wando River. **Minor** Adjustments in the centerline alignment will be allowed provided the above is met.

Maintenance & Operation of Existing Bridge During Construction

The CONTRACTOR shall be responsible for the maintenance and operation of the existing bridge during the contract time beginning when the SCDOT issues the Full Notice to Proceed. Maintenance items include but are not limited to lubrication on wedges and gears during pulling and driving operations, hydraulic leaks, generator fuel, bearing oil, etc. The CONTRACTOR is responsible for the operation of the bridge during the contract time. Historically, there are around 25 requests to open the bridge each year and 12 hour notices must be given for an opening. All costs associated with these services shall be included in the Contract Price. The CONTRACTOR is not responsible for replacing damaged or non-functioning components not caused by his own forces.

Roadway

The following items shall be included in the work:

1. Clear Zone:

CONTRACTOR shall provide adequate clear zone throughout project as defined in Exhibit 4a. In areas where **new** right-of-way or wetland impacts would be a result of achieving the **24-foot** clear zone requirement, substandard areas may be corrected or protected.

2. Pavement:

The design for pavement shall be selected from the designs listed in Exhibit 4c. The selected design shall be used throughout the length of the project.

- a) New construction areas shall be constructed using 200 lbs/sy HMA Surface Type B, 200lbs/sy HMA Intermediate Type B, and 850 lbs/sy HMA Type A. An alternate base design of 300 lbs/sy HMA Base Type A and 10 inches of Graded Aggregate Base Course may also be used in areas of new construction.
- b) Transition areas not requiring pavement reconstruction or rehabilitation but requiring revised pavement markings shall be milled 2-inches and resurfaced utilizing 200 lbs/sy HMA Surface Type B.

3. Traffic:

- a) Pavement Markings: Provide durable pavement markings and surface mounted raised pavement markers throughout the limits of the project. Striping materials will be determined by the type of roadway surface as described in Exhibit 4d. Apply line widths and patterns in accordance with the Standard Drawings.
- b) Signs: Provide and install all permanent signing within the project limits as described in Exhibit 4d including the required advanced signs for interchanges that may be located beyond the project limits. The CONTRACTOR shall provide signing plans and sign layouts for SCDOT approval prior to ordering any materials. Traffic signing shall be in accordance with requirements of the 2009 MUTCD.
- c) Traffic Signal: The signal will be designed and constructed in accordance with the South Carolina Department of Transportation Traffic Signal Design Guidelines (latest edition), the Manual on Uniform Traffic Control Devices (2009 Edition), standard signal specifications and special provisions (latest edition), and SCDOT standard drawings, SCDOT design specifications and criteria, and specific mark ups of the design.

The Signal Design work will include, but not be limited to:

- 1. Preliminary Signal Design Submittal (included in Right of Way Plans)
- 2. Final Signal Design Submittal (included in Final Plans)
- 3. Design and/or verification of appropriate signal timings (walk, don't walk, min initial, max initial, add/veh, veh ext, time bfr reduc, time to reduc, min gap, max limit, maximum 2, yellow, and red clearance)
- 4. Coordination with local governments, SCDOT Signal Maintenance and District Six Traffic engineering staff
- 5. Necessary utility coordination
- 6. Special equipment specifications
- 7. Permitting services to include permit acquisition
- 8. Any other work that may be necessary to complete the Project

Microstation (cadd) files for the original signal design and for the final layout (as-built) will be provided to SCDOT. A sealed and signed PDF will also be provided to SCDOT at the completion of the signal construction. Design package will include quantities, cost estimates and a copy of all calculations for signal design and timings.

EXHIBIT 3 – SCOPE OF WORK

Construction will include, but not be limited to:

1. All necessary signal work
2. Signal pole foundations
3. Furnish and installation of steel signal poles, cabinets/controllers, signal cable, signal span wire and signal heads
4. Integration of 2070 controller equipment in accordance with SCDOT template and all necessary burn in and testing as required by SCDOT specifications
5. Furnish and installation of pedestrian treatments including pedestrian heads, pedestrian buttons, pedestrian poles and electric cables
6. Installation of detection (detection inductive loops, video detection, wireless detection)
7. Utility coordination
8. Foundation work

Areas of work required for this project will include, but are not limited to, the following items:

1. Americans with Disabilities Acts (ADA) Compliance
2. Pedestrian Signalization
3. Geotechnical Exploration and Design (only for projects including mast arms)
4. Utility Coordination
5. Construction
6. Foundation Testing
7. As-Built Plan Preparation

4. Guardrail:

Replace all existing mainline guardrail, ramp guardrail, and end treatments within the project limits. New guardrail shall be added where necessary in order to meet current design standards. Pavement under Guardrail adjacent to paved shoulders shall be provided utilizing HMA Surface Type C at a rate of 300 psy.

Drainage and Hydrology

- A. The minimum low steel (low chord) elevation of the bridge is generally the lowest elevation of the bottom of the girders or main supporting element of the superstructure (i.e. bottom of flat slab). However, if other components, such as a pipe as part of a closed drainage system, encroach below the bottom of the girders, then the lowest elevation of the encroaching component will be considered the minimum low steel (low chord) elevation. The low chord elevation will be the constraint for setting the minimum finished grade at the bridge ends and the minimum vertical clearance above the navigable

channel. Vertical clearance over the navigable channel will be 55 feet from the lowest part of the superstructure to mean high water. Provide span lengths that meet or exceed the requirements detailed in Exhibit 4.

- B. Provide sufficient right of way that erosion control measures may be properly maintained during construction for all measures and after construction for permanent measures.
- C. A closed drainage system on the bridge is required for this project and all drainage improvements for the Project shall be carried out in accordance with Exhibit 4e.
- D. CONTRACTOR shall perform a hydraulic analysis and scour study, in accordance with the Department's "Requirements for Hydraulic Design Studies" dated May 26, 2009, to determine the required bridge length, grade, and span arrangement. Provide span lengths over the channel that meet or exceed the requirements detailed in Exhibit 4.

Structures

The Project includes, at a minimum, the following items:

- A. Design and construction of the bridge replacement included on the Cost Proposal Bid Form included as Exhibit 1. Design and construction of the bridge replacement in accordance with the criteria, specifications, and contract provisions.
- B. Provide bridge dimensions that meet or exceed the **dimensions minimum lengths and widths** shown in the Design Criteria – Exhibit 4.
- C. Remove and dispose of the existing bridge and appurtenances **as well as any foundations from previous bridges** in accordance with the SCDOT Standard Specifications for Highway Construction, Edition of 2007, Special Provisions 30 and 31, and all applicable laws and regulations. **Coordinate with the United States Geological Survey (USGS) regarding the removal and installation activities related to the storm-tide sensor brackets that are located on the existing bridge. USGS will be responsible for expenses of relocation of the brackets to the new bridge.**
- D. Piers are disallowed within the area designated for navigation – Exhibit 4.
- E. **Design and construction of a fender system in accordance with the criteria, specifications, and contract provisions.**

Geotechnical

The following items, at a minimum, shall be included in the scope of work:

- A. Provide pile and drilled shaft dynamic and/or static load testing as outlined in the design criteria and in accordance with the project specifications and Special Provisions. The results shall be used to determine axial capacities of the associated foundation system.

- B. Design and construct any ground improvement needed to ensure that the approach embankments meet the resistance factors and performance limits outlined in the SCDOT Geotechnical Design Manual (GDM). Design and construction of the ground improvement shall be in accordance with the criteria, specifications, and contract provisions.
- C. CONTRACTOR shall instrument and monitor the approach embankments, as necessary, to ensure that the performance limits outlined in the GDM are met prior to construction of pavement sections.
- D. All geotechnical design and construction for the Project shall be carried out in accordance with Exhibit 4f.

Utility Coordination

The CONTRACTOR shall conduct sufficient site surveys to locate and identify all utilities that may be affected by the bridge replacement. The CONTRACTOR shall provide utility coordination, relocation services, and identify prior rights for the construction of the Project. The CONTRACTOR shall include in his bid, the cost of coordination services for all utilities that may be affected. The cost of relocation of utilities with prior rights will be the responsibility of SCDOT. For any utility having prior rights, the CONTRACTOR will be responsible for developing the utility agreement for SCDOT approval. For those utilities where SCDOT has prior rights, the CONTRACTOR may exercise SCDOT's prior rights and require the utility company to bear the costs of relocation. CONTRACTOR shall comply with the utility coordination and relocation requirements set forth in Attachment A – Project Agreement.

Right of Way

The CONTRACTOR shall be responsible for any right-of-way acquisition required for the project, to include any relocations or permissions needed to accommodate slopes, drainage, permitting or any other Project requirements. The acquisition and all costs associated with the acquisition of additional right-of-way shall be included in the Total Project Cost by the CONTRACTOR. CONTRACTOR shall comply with right of way services and acquisition requirements set forth in Attachment A – Project Agreement. If additional right of way is necessary beyond what has been evaluated in the NEPA documentation, CONTRACTOR shall be responsible for any re-evaluation of the approved Environmental Documents.

Work Zone Traffic Control

The Project shall contain at a minimum the following items:

1. Provide all necessary Traffic Control as required by the Standard Specifications, Supplemental Specifications, Standard Drawings for Road Construction, and Special Provisions.
2. Prepare and submit a Transportation Management Plan (TMP) and special provisions for SCDOT's acceptance prior to any construction activity. The TMP includes Temporary Traffic Control, Traffic Operations, and Public Involvement plans as detailed Part 6 of the

EXHIBIT 3 – SCOPE OF WORK

Manual on Uniform Traffic Control Devices (MUTCD) latest edition and SCDOT policies including the Rule on Work Zone Safety and Mobility, the standard specifications and all addendums to the standard specifications, all supplemental specifications, the typical traffic control standard drawings for road construction and any special provisions included in this contract. All costs associated with the design, development, implementation, and maintenance of the TMP shall be the responsibility of the PROPOSER and will be included in the Total Project Cost. SCDOT shall review and accept the TMP prior to commencing any construction activities.

3. Temporary Traffic Control Plans shall be submitted to SCDOT for review a minimum of 21 days prior to beginning any work in the area. Plans shall include a description of the sequenced steps to be followed in implementing the plans, and will be developed at a scale of 1:50, unless otherwise agreed upon. Potential items for inclusion in a Temporary Traffic Control plan (TTC) will include but are not limited to lane closures, shoulder closures, road closures, traffic relocations, detours, traffic control devices, temporary pavement construction, temporary pavement markings, construction signing and sequencing notes. Maintain the number of travel lanes and all traffic movements, for the duration of the project unless otherwise approved by the Department. Design all aspects of the traffic control plan to consider lane widths, shoulder widths, clear zones, curves and reverse curves, lane shifts, taper lengths, lane drops, stopping sight distance, buffer areas, placement of traffic control devices, etc. and to comply with the speed requirements of the roadway prior to initiation of the project or beginning the work or the implementation of a reduced speed limit due to a previous road defect.
4. The CONTRACTOR shall execute all Traffic Control in accordance with Exhibit 4d – Part 2.

Hurricane Evacuation Readiness

The present two lane operation of SC 41 shall remain during this bridge replacement project. SCDOT approval is necessary should any project work require any notable operational change in this two lane traffic plan. Plans, including signing and marking changes, shall be submitted to SCDOT 60 days in advance of any expected alterations.

Environmental

The CONTRACTOR shall give extra attention throughout his operations to minimizing impacts to the environment. As a minimum the CONTRACTOR shall include the following in the Project:

- A. SCDOT has prepared the necessary environmental documents consistent with the NEPA process including any necessary studies. The project has been advanced through the environmental phase with the approval of an Environmental Assessment and a subsequent Finding of No Significant Impact (FONSI), a copy of which is included in Attachment B. In preparing the environmental documentation, SCDOT has made certain assumptions regarding project construction. If the PROPOSER elects to construct the

EXHIBIT 3 – SCOPE OF WORK

project in a manner that is not consistent with the assumptions in the SCDOT prepared environmental documents, the PROPOSER will be responsible for preparing any necessary environmental re-evaluation and providing any additional studies that may be required. All revisions to or re-evaluations of the environmental documents will require SCDOT and FHWA approval prior to any construction activity. It is the PROPOSER'S responsibility to comply with all commitments listed in the environmental documents.

- B. The CONTRACTOR will be responsible for obtaining any permits required by federal, state, or local laws or regulations. All work, including additional cost and time associated with any permit or permit modification as a result of changes proposed by the CONTRACTOR shall be the CONTRACTOR's responsibility. The CONTRACTOR will not be entitled to any additional cost or time associated with obtaining any permit required. CONTRACTOR will be responsible for obtaining any permits required by federal, state, or local laws or regulations.
- C. For those permits that must be submitted in the name of SCDOT, the permit applications shall be forwarded to SCDOT for review and submission. Coordination with agencies must be routed through the SCDOT Environmental Management Office. ~~Where possible, SCDOT will assign the CONTRACTOR to act as the SCDOT's agent in coordinating permit approval.~~ The CONTRACTOR shall stake out and delineate the jurisdictional areas in accordance with the preliminary jurisdictional determination issued by the USACE, and OCRM's approved Critical Line plat, and the project Special Provisions. It is anticipated that a United States Coast Guard Permit, Section 404 Permit, and a Section 401 Water Quality Certification are required and shall be the responsibility of the CONTRACTOR to obtain.
- D. All mitigation expenses will be the responsibility of the CONTRACTOR. All costs of obtaining the permits, including any mitigation required by permits shall be the responsibility of the CONTRACTOR and included in the Total Project Cost. The Design/Builder may use an SCDOT approved wetland mitigation bank, at no cost, for wetland impacts per SCDOT's mitigation banking instrument and in accordance with USACE Charleston District's standard method of operation. SCDOT has no stream mitigation banks and SCDOT escrow accounts will not be a viable option for stream mitigation. Therefore, any stream mitigation shall be the responsibility of the CONTRACTOR.
- E. All work associated with any permit modifications as a result of changes proposed by the CONTRACTOR shall be the CONTRACTOR's responsibility. The CONTRACTOR will not be entitled to any additional cost or time associated with obtaining any permit required as a result of CONTRACTOR design change, except as provided in Article IX - Permits in Attachment A – Project Agreement.
- F. The CONTRACTOR shall provide an Environmental Plan for the Project. The plan shall be submitted to SCDOT for approval prior to any construction activity. The plan shall identified specific measures that the CONTRACTOR will implement to assure compliance with all environmental documents, permits, and other environmental commitments as may be detailed in the contract documents. The plan shall also designate

specific personnel that are charged with carrying out monitoring and compliance activities included in the plan.

G. The CONTRACTOR shall fulfill all Environmental Commitments in Exhibit 8.

H. All jurisdictional areas not to be impacted should be delineated/identified for protection by temporary barrier fencing as per instructions identified in Instructional Bulletin dated March 14, 2013. A copy of the Bulletin is included in Attachment B.

Partnering

SCDOT values a partnering approach on projects and as such this project will require regular Partnering Sessions. The objectives are effective and efficient contract performance and completion within budget, on schedule, and in accordance with the contract requirements. **The CONTRACTOR is not to include the cost of partnering activities in the Total Project Cost.** The cost of the partnering activities will be shared equally between the CONTRACTOR and SCDOT. The CONTRACTOR should anticipate two (2) Partnering Sessions for this Project.

Community Relations

The CONTRACTOR shall provide to SCDOT for review and written approval a Community Relations Plan as part of the Project. The Community Relations Plan shall describe how the CONTRACTOR will actively promote good relationships with local elected officials, the news media, and the community at large. All costs associated with community relations will be included in the Total Project Cost. SCDOT will expect the CONTRACTOR to maintain positive communications with the local community (including public meetings as necessary), the adjacent property owners, and local businesses.

The Project includes compliance with Engineering Directive Memorandum Number 36, Public Notification of Bridge Replacement Projects. All public notification correspondence shall be prepared for the signature of the appropriate SCDOT Official as required by Engineering Directive Memorandum Number 36. The Contractor shall also regularly advise local media in advance of road closures and when the road is reopened to traffic.

EXHIBIT 4

PROJECT DESIGN CRITERIA

EXHIBIT 4 – PROJECT DESIGN CRITERIA

This exhibit details the criteria by which the project must be designed and constructed. These criteria are divided into subsections as listed below:

Exhibit 4a. Road

Exhibit 4b. Structures

Exhibit 4c. Pavement

Exhibit 4d. Traffic

Part 1 – Signing and Pavement Markings

Part 2 – Work Zone Traffic Control

Part 3 – Traffic Signal Design and Specifications

Exhibit 4e. Hydraulic

Exhibit 4f. Geotechnical

DESIGN REFERENCES

This exhibit describes the general design considerations and criteria for the proposed roadway approaches, hydraulics, structures, traffic signal design, and surveys.

Design standards shall be in accordance with the following design references as supplemented or amended by Sections 4a, 4b, 4c, 4d, 4e, and 4f of this Exhibit:

- SCDOT Pre-Construction Survey Manual, effective as of Final RFP release date
- 2003 SCDOT Highway Design Manual with updates effective as of the Final RFP release date and supplemented with AASHTO A Policy on Geometric Design of Highways and Streets, 2001
- AASHTO Roadside Design Guide, with 2006 Chapter 6 update, 3rd Edition
- SCDOT Requirements for Hydraulic Design Studies, May 2009
- SCDOT Standard Drawings, effective as of the Final RFP release date
- SCDOT Engineering Directive Memorandums, effective as of the Final RFP release date
- SCDOT Instructional Bulletins, effective as of the Final RFP release date
- AASHTO Guide for the Development of Bicycle Facilities, 1999
- AASHTO Guide for the Planning, Design, and Operation of Pedestrian Facilities, 2004
- SCDOT Americans with Disabilities Act Transition Plan, January 2009
- SCDOT Roadside Plants to Avoid/Trees with Limitations on R/W, June 2008
- SCDOT Access and Roadside Management Standards, August 2008 with updates
- SCDOT Plan Preparation Guide, 2000
- SCDOT Standard Specifications for Highway Construction, 2007
- SCDOT Supplemental Specifications, effective as of the Final RFP release date
- SCDOT Supplemental Technical Specifications, effective as of the Final RFP release date
- SCDOT Qualified Product Lists, effective as of the Final RFP release date
- FHWA Manual on Uniform Traffic Control Devices (Latest Edition)
- SCDOT Supplement to the MUTCD
- The Rule on Work Zone Safety and Mobility
- SCDOT Traffic Signal design Guidelines, 2009 with updates
- Highway Capacity Manual, 2000
- SCDOT Traffic Engineering Guidelines
- SCDOT Preconstruction Advisory Memorandums, effective as of the Final RFP release date
- AASHTO “Highway Drainage Guidelines”
- SCDOT Bridge Design Manual, 2006
- SCDOT Bridge Design Memoranda, effective between July 1, 2006 and the Final RFP release date
- 2010 AASHTO LRFD Bridge Design Specifications, Fifth Edition (with 2010 Interim Revisions)
- SCDOT Geotechnical Design Manual, 2010 Edition (Version 1.1)

- SCDOT Seismic Design Specifications for Highway Bridges, 2008 (Version 2.0)
- SCDOT Bridge Design Drawings and Details, effective as of the Final RFP release date
- AASHTO/AWS D1.5M/D1.5:2010 Bridge Welding Code, with 2011 interims
- AASHTO “Standard Specifications for Structural Supports for Highway Signs, Luminaires and Traffic Signals”, effective as of the Final RFP release date
- Road Design Reference Material for Consultant Prepared Plans, June 2010
- Highways in the Coastal Environment, HEC 25, June 2008, 2nd Edition
- Tidal Hydraulic Modeling for Bridges, Ayres Associates, March 2002
- 2009 Edition of SCDOT’s Signal Design Guidelines
- SCDOT Traffic Signal Specifications (latest Edition)

Any variation in design from the included information shall require written approval from SCDOT.

Abbreviations

The following abbreviations will be used herein to designate standard specifications for material and workmanship:

- AAMA - American Architectural Manufacturers Association
- AASHTO - American Association of State Highway and Transportation Officials
- ADA – Americans with Disabilities Act
- AISI - American Iron and Steel Institute
- AISC - American Institute of Steel Construction
- ALSC - American Lumber Standard Committee
- ANSI - American National Standard Institute
- ASTM - American Society of Testing Materials
- AWS - American Welding Society
- CRSI - Concrete Steel Reinforcing Institute
- FHWA - Federal Highway Administration
- GDM – SCDOT Geotechnical Design Manual
- IEEE-Institute of Electrical and Electronic Engineers
- LRFD - Load and Resistance Factor Design
- LRFR – Load Rating and Resistance Factor Rating
- MUTCD – Manual on Uniform Traffic Control Devices
- NEMA - National Electrical Manufacturers Association
- NETA- International Electrical Testing Association
- OSHA - Occupational Safety and Health Act
- PCI – Prestressed Concrete Institute
- RCE – SCDOT Resident Construction Engineer
- SCDOT - South Carolina Department of Transportation
- SSPC - Steel Structure Painting Council

DESIGN DELIVERABLES

The CONTRACTOR is solely responsible for the accuracy, completeness, and constructability of the submitted deliverables before and after review. The CONTRACTOR is reminded that the SCDOT reviews the working drawings and design calculations only to insure that the specifications have been addressed.

All submittals to SCDOT shall be subjected to a thorough QA/QC review by the CONTRACTOR prior to submittal and all final submittals shall be signed and sealed by the Engineer of Record who shall be licensed and registered as a Professional Engineer in the State of South Carolina

ROADWAY DESIGN DELIVERABLES

Preliminary Plans

Eight (8) sets of preliminary plans shall include, at a minimum: roadway typical section, roadway plan and profile, cross sections, drainage features, proposed right-of-way, construction staging details, and preliminary geotechnical reports.

CONTRACTOR shall also provide any design calculations requested in writing by SCDOT. CONTRACTOR shall also provide one electronic copy of the plans and calculations.

Right of Way Plans

Eight (8) sets of Right of Way plans are not a required submittal. However, if right of way is required and the CONTRACTOR wishes to pursue right of way acquisition prior to Final Plan submittal, CONTRACTOR has the option to submit Right of Way Plans. If the CONTRACTOR elects to submit Right of Way plans, one electronic copy is required.

Right of Way plans shall include, at a minimum: Right of Way data, roadway typical section, roadway plan and profile, cross sections, drainage features, existing Right of Way, and proposed new Right of Way requirements.

Final Plans

Eight (8) sets of Final plans shall include, at a minimum: roadway typical section, roadway plan and profile, cross sections, drainage features, sediment and erosion control features, existing right-of-way, proposed right-of-way, construction staging details, proposed barrier locations, and final geotechnical reports. CONTRACTOR shall also provide any design calculations requested in writing by SCDOT. CONTRACTOR shall provide one electronic copy of the plans and calculations.

As – Built Construction Plans shall adhere to Road Design Reference Material for Consultant Prepared Plans, latest edition for Construction Plans.

HYDRAULIC DESIGN DELIVERABLES

Preliminary Hydraulic Design Submittal

The CONTRACTOR shall provide the Hydraulic Design Calculations to SCDOT with the Preliminary Plans. Hydraulic Design Calculation submittal shall include calculations for drainage structures and calculations for sediment and erosion control and all calculations associated with the bridge.

Final Hydraulic Design Submittal

The CONTRACTOR shall provide the following to the Department with the Final Plan submittal:

- Four (4) ~~Eight (8)~~ signed, completed copy of the SCDHEC Notice of Intent (NOI), and CZC package (if applicable)
- Four (4) copies of the Bridge Hydrology and Hydraulic Report,
- Four (4) ~~Eight (8)~~ copies of the Final Drainage Report and Stormwater Management Report,
- Four (4) ~~Eight (8)~~ complete “No-Impact” ~~“No-Rise”~~ Certification, ~~if applicable, and~~
- ~~Four (4) Eight (8) complete CLOMR and LOMR FEMA Packages, if applicable.~~
- One electronic copy of each submittal.

STRUCTURAL DESIGN DELIVERABLES

Preliminary Structural Design Plans

Where applicable, SCDOT Bridge Drawings and Details shall be utilized (available on SCDOT website).

The Contractor shall submit preliminary plans. Three copies of the preliminary geotechnical report and an electronic copy shall be included with the preliminary plans submittal. SCDOT and its representatives will have 21 days from date of receipt to review and either accept or provide comments on the plan submittal. No final design shall begin until comments are resolved and SCDOT acceptance is given.

Design drawing submittals to SCDOT shall include at least one full size (22” x 36”) set and eight half size sets. One electronic copy is also required.

Preliminary Seismic Design Summary Report

Along with the preliminary bridge plans submittal, the Contractor shall submit preliminary seismic summary report (three copies and one electronic copy) documenting the strategy that will be used to achieve the required seismic performance criteria for the bridge. The

report shall describe the seismic design approach for the bridge and shall include, at a minimum, the following information:

- A discussion of the expected performance of the bridge in regard to elastic and inelastic behavior (locations where plastic hinging is expected)
- Target ductility demand
- A description of design features required to meet the critical performance requirements of the *SCDOT Seismic Design Specifications for Highway Bridges*
- The name(s) of computer software that will be used for modeling
- Any unique structural and geotechnical issues affecting the seismic design
- The design response spectrum (when a site-specific study is required)

If any changes to the seismic design strategy are made during the design process, the Consultant shall modify the report and resubmit it to the Department for review.

Final Structural Design Plans

Final Structural Design Plans shall include six (8) half size sets, one (1) full size set, and one electronic copy and, at a minimum, all documents, reports, and calculations described in Chapter 3 of the SCDOT Bridge Design Manual. Three (3) copies of the final geotechnical report and one electronic copy shall be included with the final plans submittal.

Final plan submittals to SCDOT shall be signed and sealed by the State of South Carolina licensed Professional Engineer of record. CONTRACTOR shall provide any design calculations requested in writing by SCDOT. No construction shall begin until all comments are resolved and SCDOT acceptance is given.

Final Seismic Design Summary Report

Along with the final bridge plans submittal, the Contractor shall submit final seismic summary report (three (3) hard copies and one electronic copy).

Release for Construction (RFC) Plans

For roadway and structural plans, CONTRACTOR shall provide one (1) full size sets, eight (8) half size sets, and one electronic copy of RFC Plans to SCDOT. RFC Plans shall be inserted into plan folders as detailed in the SCDOT bridge design manual and the SCDOT plan and preparation guide.

Foundation Installation Plans

The CONTRACTOR shall prepare Drilled Foundation Installation Plans (DFIP) and/or Pile Installation Plans (PIP) in accordance with the Standard Specifications for Highway Construction. The CONTRACTOR's designer shall review and approve all DFIP and PIP (including pile driving criteria) prior to submitting the foundation installation plans to

SCDOT for review and acceptance. SCDOT will review the foundation installation plans and provide either acceptance or comments. Comments must be resolved by the CONTRACTOR's designer prior to re-submittal to SCDOT. The CONTRACTOR is reminded that the SCDOT reviews the DFIP and/or the PIP only to insure that the specifications have been addressed.

Shop Plans

Shop plans, as defined by the Standard Specifications for Highway Construction, shall be submitted to the CONTRACTOR's designer for review and approval. All approved shop plans shall be routed to SCDOT for review and distribution. Shop plan submittals shall meet the criteria of Subsection 725.1.1 of the Standard Specifications for Highway Construction. After reviewing the plans, SCDOT will either distribute the plans or provide comments. Comments shall be reviewed and approved by the CONTRACTOR's designer prior to the plans being resubmitted to the SCDOT for further review. Shop plans shall be stamped "approved" by the CONTRACTOR's designer prior to submittal to SCDOT and shall be stamped and distributed by the SCDOT prior to commencing fabrication and/or construction/erection. All design calculations and shop plans shall bear the legible seal, date, and signature of the responsible engineer registered as a Professional Engineer in the State of South Carolina.

As supplement to Standard Specification Subsection 725.1.1, processing of Shop Plans shall be in accordance with Bridge Design Memorandum – DM0207 which could be found on SCDOT web site <http://www.scdot.org/doing/structural.aspx>.

Working Drawings

Working drawings and design calculations, as defined by the Standard Specifications for Highway Construction, shall be submitted to the CONTRACTOR's designer for review and approval. All approved working drawings and design calculations shall be routed to the SCDOT for review and distribution. Working drawings and design calculation submittals shall meet the criteria of Subsection 725.1.2 of the Standard Specifications for Highway Construction. SCDOT will review the drawings and calculations and either provide acceptance of the drawings as prepared or provide written comments to the drawings. Comments shall be reviewed by the CONTRACTOR's designer prior to re-submittal to the SCDOT for further review. Working drawings and design calculations shall be stamped "approved" by the CONTRACTOR's designer prior to submittal to SCDOT and shall be stamped and distributed by the SCDOT prior to commencing construction/erection. All design calculations and working drawings shall bear the legible seal, date, and signature of the responsible engineer registered as a Professional Engineer in the State of South Carolina.

GEOTECHNICAL DESIGN DELIVERABLES

EXHIBIT 4 – PROJECT DESIGN CRITERIA

The CONTRACTOR shall prepare separate preliminary and final geotechnical reports for the bridge, and separate preliminary and final geotechnical reports for the roadway which shall include the geotechnical design of roadway embankments, retaining walls, culverts, and/or any other roadway structure. ~~a preliminary and final geotechnical engineering report for all bridges, retaining walls, roadway embankments, culverts and any other structures constructed for this Project.~~ The reports shall, as a minimum, contain all that is described in Chapter 21 of the *SCDOT Geotechnical Design Manual*. Also, the reports shall have design details and plan notes along with data that are consistent with that shown in the preliminary and final bridge and road plans. In addition, the CONTRACTOR's designer shall prepare the required geotechnical roadway plan sheets that clearly detail any geotechnical requirements outlined in the reports. The reports and plans shall bear the legible seal, date, and signature of the responsible engineer registered as a Professional Engineer in the State of South Carolina. Each report shall be submitted to SCDOT along with the preliminary or final bridge or road plan submittal. The review of the reports and plans will be performed in accordance with the submittal plan review process. Three (3) copies of each report shall be provided to SCDOT. In addition, the Contractor shall provide a complete copy of the final report in PDF format to SCDOT. The CONTRACTOR shall also submit three (3) copies of each dynamic and/or static foundation load test report to SCDOT. After construction of the foundations is complete, the CONTRACTOR shall provide a supplement to the report containing the actual field conditions encountered and as-built foundation data and information.

EXHIBIT 4a

ROADWAY DESIGN CRITERIA

Section 1
INTENT OF DESIGN CRITERIA

The CONTRACTOR will be expected to design and construct the project according to these design requirements.

Design criteria were established based on design speed, character and composition of traffic and width of right of way. These criteria were derived directly from the South Carolina Department of Transportation (SCDOT) Highway Design Manual and supplemented with AASHTO "A Policy on Geometric Design of Highways and Streets," 2001 Edition.

Section 2
DESIGN CRITERIA

The terrain on all routes within the scope of work shall be classified as level. A WB-62 design vehicle shall be utilized for all geometric design, except where otherwise noted.

Route	Design Speed	Functional Classification to be used for design
SC 41	45 mph	Urban Arterial
S-33 (Clements Ferry Rd)	45 mph	Collector
*Access Road	20 mph	Local (Group 2)

*Access Road is shown on the Public Meeting Display

The typical sections shown in Figure 1 should be used for the project. The full width median shall, at a minimum, begin at the south end bridge approach slab and continue through the relocated intersection of SC 41 and S-33 Clements Ferry Road tapering back down to a 2 lane section beyond the auxiliary lanes serving the intersection at approximately Sta. 302+00.

EXHIBIT 4a – ROADWAY DESIGN CRITERIA

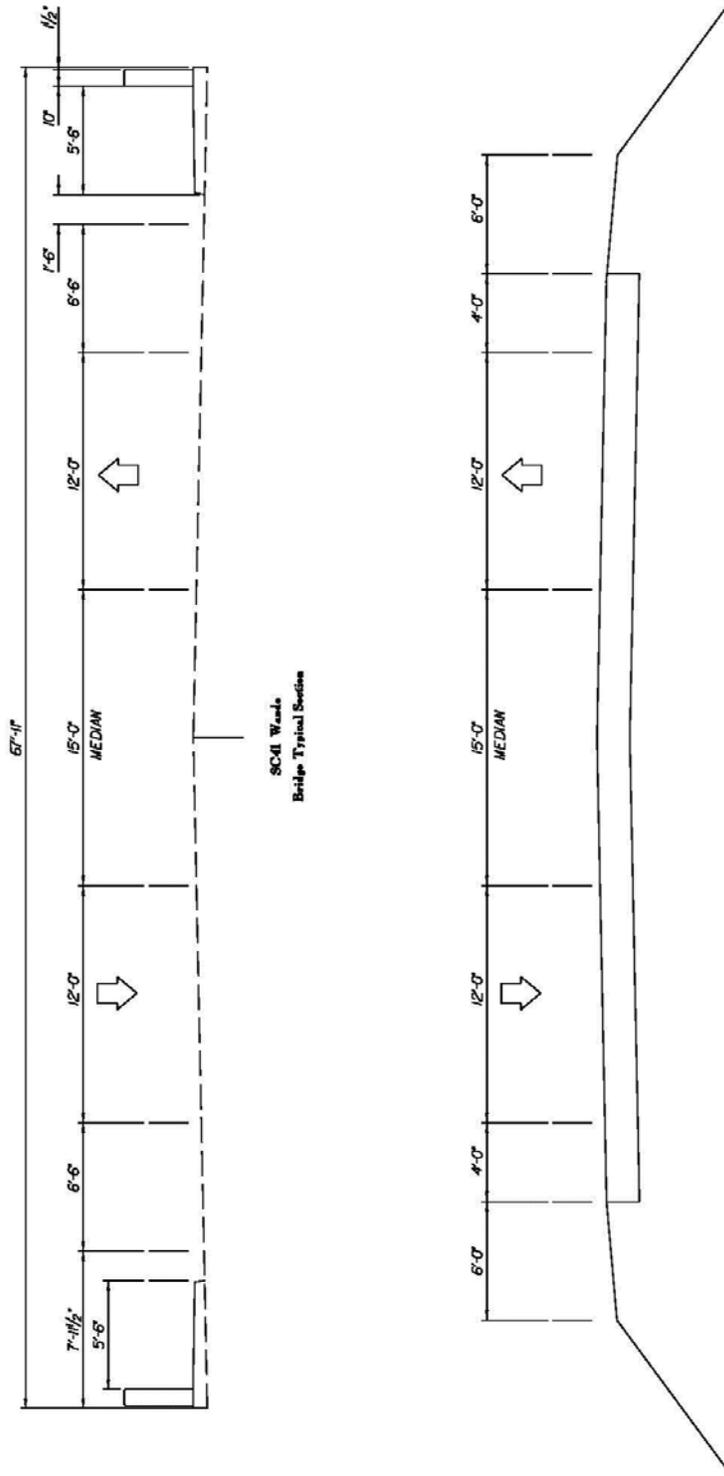

Figure 1

Section 3

RIGHT-OF-WAY AND CONTROL OF ACCESS

Right-of-way

Right of Way shall be acquired in accordance with Section VIII of the Project Agreement.

Minimum Widths Required

The CONTRACTOR will be expected to design and secure right of way in accordance with these requirements. For existing right of way to be retained, the CONTRACTOR can retain the existing width.

Route	Minimum Right of Way width	See footnotes for additional requirements
SC 41	Retain existing	Arterial
S-33 (Clements Ferry Rd)	Retain Existing	Collector
Access Road	50 feet	Local (Group 2)

Arterial – Cover limits of improvement along route with minimum right of way width specified above. Design build team is allowed to secure necessary permissions for construction beyond minimum width. If permissions are not secured fee simple right of way shall be secured.

Bridge – Secure right of way box to cover bridge area in accordance to chapter 12 section 11-Bridge Location of the Plan Preparation Guide using widths specified above.

Collector – Design build team is allowed to secure necessary permissions for construction outside minimum width specified. If permissions are not secured fee simple right of way may be required.

Local (Group 2) – Design build team shall identify the right of way width necessary to construct and maintain the new Access Road following the alignment as shown on the public meeting displays in Attachment B.

Right of way lines should maintain uniform alignment for 300’ minimum and not fluctuate in and out.

Section 4
CLEAR ZONE

Clear zone for all areas shall be as defined in the SCDOT Highway Design Manual, Chapter 14 and supplement with 2002 AASHTO Roadside Design Guide with Chapter 6 updates.

Section 5
SIGHT DISTANCE

The SCDOT Highway Design Manual Chapter 10 – Sight Distance will be used.

The upper range value established in the current edition of AASHTO's "A Policy on Geometric Design of Highways and Streets," 2001, for the appropriate design speed will be used.

Section 6
ACCESS ROAD (NEW LOCATION)

A new location Access Road, as shown in the Public Meeting displays, will be required to provide access to the Detyens Shipyard and Atlantis Marine sites. The angle of intersection must be within 20 degrees of the perpendicular. The intersection design shall include dedicated left and right turn lanes on SC 41.

Section 7
RELOCATED SC 41

A relocated alignment will be required on SC 41 at the intersection with S-33 to achieve an angle of intersection within 20 degrees of the perpendicular. The intersection design shall include a dedicated right turn lane on S-33 northbound at SC 41, an auxiliary left turn lane on southbound S-33 at SC 41, and dedicated left and right turn lanes on SC 41 at S-33. See Figure 2.

EXHIBIT 4a – ROADWAY DESIGN CRITERIA

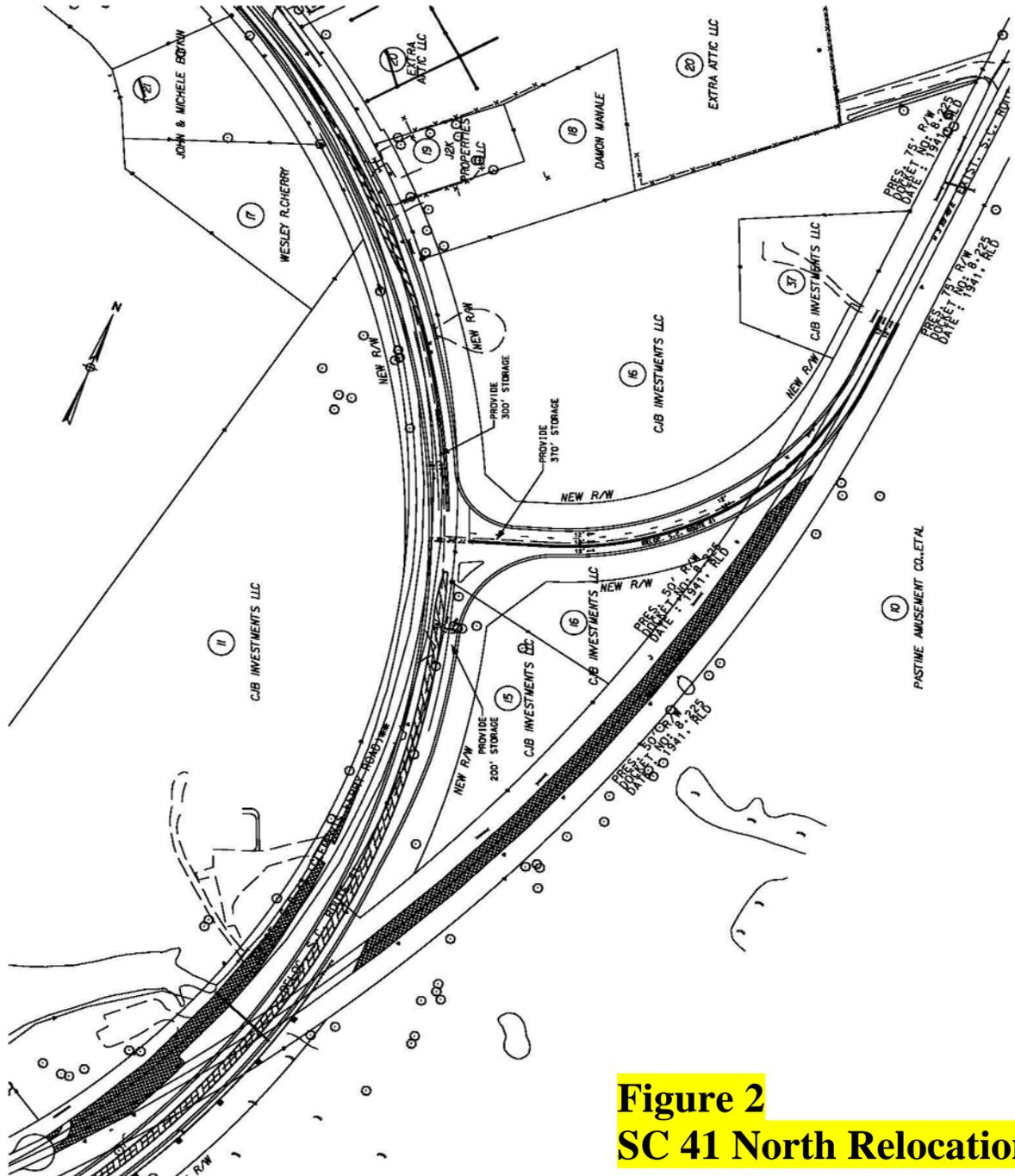

Figure 2
SC 41 North Relocation

EXHIBIT 4b

STRUCTURES DESIGN CRITERIA

1. PROJECT SPECIFIC REQUIREMENTS

Navigational Clearances

Clear horizontal navigational clearance of a minimum of 90 feet, measured from channel face of fender system to channel face of fender system.

The main channel span clear vertical navigation clearance shall be of no less than 55 feet vertical clearance above mean high tide across the entire limits of horizontal clearance specified herein.

Coast Guard Permit

Contractor shall be responsible for obtaining all necessary U.S. Coast Guard permits.

Prior to commencement of detailed design, Contractor should submit and receive approval of U.S. Coast Guard Permits to prevent possible rework.

Stream Loads

Loads caused by stream flow in the ebb and flood direction shall be considered in the design of the Substructure elements. A resulting stream flow velocity shall be determined by the contractor's appropriate 2-D hydraulic analysis. The "Final Hydraulic Design for Bridge Replacement over Wando River" Report prepared by Ayres Associates has been provided as an aid to the contractor to finalize his hydraulic analysis, is valid and may be used as the appropriate 2-D hydraulic analysis. In the event that the proposed bridge configuration does not fit that provided in the Ayres Study, the contractor may shall alter the bridge configuration in the model and submit an updated signed and sealed study or the contractor can develop their own independent 1D hydraulic model to perform the analysis. A signed and sealed (by a SC registered Professional Engineer) hydraulic analysis report documenting the analysis procedures and results shall be submitted for review and approval by SCDOT as part of the design process. The water surface shall be assumed to be at the high water/flood tide elevation for this condition. Scour analysis shall be performed in accordance with SCDOT requirements.

Reference is made to the "Final Hydraulic Design for Bridge Replacement over Wando River" Report, prepared by Ayres Associates, for previously obtained design values/parameters for the bridge configuration depicted in the For Information Only preliminary plans.

Storm Surge Criteria

Loads generated by the 100 year storm event shall be considered in the design. All bridge elements shall be designed to resist loading from both the ebb and flood direction.

Wind Loads

The design wind velocity, V_{DZ} , of Bridges or parts of bridges more than 30.0 ft above low ground or water level shall be adjusted in accordance with AASHTO 3.8.1.1. V_{30} shall be established from the fastest-mile-of-wind charts available in ASCE 7.

Isolation Devices

If isolation devices are used, the design, detailing and testing of seismic isolation devices shall be in accordance with the provisions of the AASHTO Guide Specifications for Seismic Isolation Design, 3rd Edition, 2010. The bearings shall be included in the detailed seismic model.

Isolation bearings should not be specified unless testing reports are available which demonstrate adequate performance at the vertical loads and horizontal displacements determined by analysis.

Vessel Collision Analysis Criteria

1. General Requirements

A vessel collision analysis shall be performed in accordance with Section 3.14 of AASHTO and AASHTO Vessel Collision Design of Highway Bridges, 2nd Edition, 2009, with 2010 Interim revisions.

The Method I Acceptance Criteria shall be used for the analysis and shall adhere to the Bridge Operational Classification of “Critical/Essential”.

~~Vessel collision design loads shall not be reduced through the use of fender systems.~~ Although a fender system is required to be constructed at the navigational channel, the fender system shall not be considered when determining the vessel collision design loads for the bridge substructure.

Dynamic analysis techniques that take into account force-deformation, or other dynamic interaction, between the collision vessel and bridge structure during collision shall not be used.

2. Collision Analysis

The vessel collision analysis shall, as a minimum, take into consideration the following two collision events:

Event 1 – Drifting empty barge impacting vulnerable bridge elements. The vessel impact loads shall be combined with one-half of the predicted long-term scour plus one-half of the predicted short-term scour. This event shall correspond with the 100-yr flood event.

Event 2 – Ship & Barge tow impacting vulnerable bridge elements while in transit. The vessel impact loads shall be combined with one-half of the

predicted long-term scour, with no short-term scour. This event shall correspond with a low and high tide event.

The long-term and short-term scours shall be as defined in the AASHTO Vessel Collision Design of Highway Bridges Guide Specification.

Based on the channel vertical clearance that is being provided, superstructure vessel collision forces do not need to be considered.

3. Design Vessel

The design vessel shall be a single Small Deck Barge (32 ft x 150 ft) with an empty displacement of 200 ton. Draft when empty shall be assumed to be 2 ft.

In addition, the loaded barge shall have a maximum displacement tonnage of 600 tons. Draft when loaded shall be assumed to be 6ft. Assume the head log height to be 3 feet, the depth of vessel to be 10 feet, the depth of bow to be 10 feet, and the bow rake length to be 20 feet.

Towboat shall be assumed to be a Harbor Boat (<600 horsepower) with a size of 20 ft x 50 ft. Towboat shall have an assumed draft of 5 ft and a gross displacement tonnage of 45 tons. Speed of combined vessels under power shall be assumed to be a maximum of 6 knots, not including tide induced water velocity. Vessel impact speed may be distributed in accordance with the AASHTO Guide Specifications for Vessel Collision Design of Highway Bridges.

4. Supplemental Information

Reference is made to the “Final Hydraulic Design for Bridge Replacement over Wando River” Report, prepared by Ayres Associates, for previously obtained design values/parameters. ~~and as validated or modified by the Contractors final 2D model.~~

Corrosion Mitigation Requirements

Concrete cover shall be as defined in the Bridge Design Manual and Bridge Design Memorandums with the following modifications:

Bridge Element	Clear Cover*
Concrete within the Splash Zone, Water Column and/or Scour Zone	4 ½”
Concrete Cast Against and Permanently Exposed to Earth	4 ½”
Concrete Exposed to Earth or Weather	4”
Prestressed Concrete Piles	3 ½”
Drilled Shafts in Soil (applies to hoops)	6”

* Clear Cover is defined as the clear distance from the surface of the concrete to the face of the closest interior reinforcing steel, including ties or spirals.

The splash zone is the vertical distance from 4 feet below Mean Lower Low Tide Water elevation provided in the Hydrology Study to 12 feet above Mean Higher High Tide Water elevation provided in the Hydrology Study.

The scour zone is the vertical distance from the natural ground elevation to the scour elevation.

Corrosion inhibitor shall be added to concrete mix designs for all substructure components, excluding shaft concrete, located within the splash zone and water column, including the scour zone. Dosage of inhibitor shall be as recommended by Manufacturer on SCDOT QPL list.

Type II cement shall be used for cast-in-place elements located within the splash zone, such as pier columns and pier caps.

Steel piles shall not be used in the splash zone or water column, including the scour zone. The Contractor shall design any steel piles for a 75 year service life based on results of Corrosion Series Testing prescribed in the GDM and the following corrosion rate:

Soil Embedded Zone: 0.001 inch per year

Final Finish of Exposed Concrete Surfaces

~~Final surface finish shall be applied to the entire surface of all barrier rails, parapet walls, approach slab curbs, wingwalls; outside vertical edges of bridge deck slabs, sidewalks and exposed caps, including channel piers. Final surface finish shall be in accordance with Subsection 702.4.11 of the Standard Specifications. No final surface finish is required.~~

Stay-in-place Bridge Deck Forms

Permanent stay-in-place steel bridge deck forms for concrete deck slabs may be used at the Contractor's option. Fillers shall not be used in the flutes of the stay-in-place forms. Form flutes shall be filled with concrete as the deck slab is placed.

Bridge Decks

Bridge decks supported by girders or beams shall be reinforced cast-in-place concrete with reinforcing steel. All bridge decks shall comply with the rideability requirements of Subsection 702.4.14.1 of the Standard Specifications. The Contractor shall be responsible for coordinating with the SCDOT for scheduling the profilograph test, which is to be conducted by SCDOT.

Concrete Strengths

In prestressed concrete piles and beams, concrete strengths up to 8,000 and 10,000 psi maximum, respectively, may be used. All cast-in-place concrete bridge components shall be constructed with concrete having a minimum compressive strength of 4000 psi. All precast concrete bridge components shall be constructed with concrete having a minimum compressive strength of 5000 psi.

Below Strength Concrete

For purposes of applying the reduced payment and below strength provisions of Sections 701.2.12.4.1 and 701.2.12.4.2.4 of the Standard Specifications, a unit price of \$750/CY will be used. When design analysis is required to verify the acceptance of below strength concrete, it shall be performed by the Engineer of Record and shall be submitted to the SCDOT for approval.

Superstructure Types

For this project, Section 12.3.3 of the *SCDOT Bridge Design Manual* shall not be used. Allowable superstructure types are outlined in Sections 12.3.2.1, 12.3.2.3 and 12.3.2.4 of the *SCDOT Bridge Design Manual*.

If prestressed concrete girders are used as outlined in Section 12.3.2.1 of *SCDOT Bridge Design Manual*, they shall be either I-beams or modified bulb-tee beams.

If structural steel girders or beams are used as outlined in Sections 12.3.2.3 or 12.3.2.4 of *SCDOT Bridge Design Manual*, they shall be “I” shaped.

Substructures

Interior Bents shall consist of cast-in-place reinforced concrete bent caps and columns supported on cast-in-place reinforced concrete drilled shafts or pile footings.

End abutment shall be either vertical abutments or spill through type abutments (2:1 maximum slope). Vertical abutments shall be constructed of cast-in-place reinforced concrete.

Bent caps may be sloped as outlined in Section 20.1.7 of *SCDOT Bridge Design Manual*.

Integral Interior Bent Caps

If required on this Project, integral interior bent caps shall be constructed of concrete.

Foundation Design

Bridge spread footings will not be permitted. Deep foundations are required to extend below any compacted fill, including MSE wall backfill.

Pile Sizes and Types

Minimum pile sizes and acceptable pile types are listed below. No other pile types will be permitted.

Pile Type	Minimum Size
Steel H-Piles	HP12x53
Steel Pipe Piles	16 inch diam. (min. wall thickness equal to ½ inch)
Prestressed Concrete Piles	*18 inch square
Prestressed Concrete Pile Points	W8x58
**Timber Piles	8 inch tip Diameter

*16 inch square piles for fender system

**Timber Piles may only be used for ground improvement and fender system

Steel Pipe Pile Connection Details

If the Contractor elects to utilize steel pipe piles, the pile connection detail described in Item 2 of Section 19.2.6.3 of the *SCDOT Bridge Design Manual* shall not be used for this Project. Steel pipe piles shall be terminated at the bottom of the cap or footing and the piles must be connected to the bent cap using a reinforced concrete infill, with the reinforcing extending into the cap or footing.

Cross-Hole Sonic Logging (CSL) Testing

Cross-hole sonic logging (CSL) access tubes shall be installed in all drilled shafts in accordance with the *Standard Specifications for Highway Construction*. CSL testing will be conducted by SCDOT on all of the shafts.

Bridge Railing

The SCDOT 42 inch concrete wall shall be used. See Item #2 in Section 17.6.1.2 of the Bridge Design Manual along with the pedestrian Railing Wall Detail on Bridge Drawings and Details, Drawing No. 700-Misc.

Slope Protection

Provide slope protection for the bridge end fills. The end fills at the northern end of the bridge shall be protected with rip rap in accordance with Standard Drawing 804-105-00. The end fill at the southern end of the bridge shall be protected with concrete slope protection in accordance with the Bridge Drawing Details, Drawing No 804-01.

2. ROADWAY STRUCTURES

Reinforced Concrete Walls

For walls separating traffic with grade differentials less than 12 feet, Standard Median Barrier Types 11 through 15 may be used as shown in the *SCDOT Standard Drawings*. These standard concrete median barrier walls may be used provided that the foundation soils meet the foundation design requirements indicated on the *SCDOT Standard Drawings*.

Spread footings are permitted for concrete retaining walls that are not directly supporting bridges.

Other Wall Types

Other acceptable wall types include walls, Precast Counterfort walls (which may be used in conjunction with traditional MSE walls in partial rock cuts), Tangent Pile/Secant Pile walls, Anchored walls, and Soil-nailed walls. Use form liners or veneer if brick or masonry appearance is desired.

Wall loadings for anchored wall systems shall be computed in accordance with FHWA Publication No. FHWA-IF-99-015 entitled Geotechnical Engineering

Circular No. 4, Ground Anchors and Anchored Systems, 1999. AASHTO wall loadings for anchored wall systems shall not be used.

SCDOT Standard Brick walls shall not be used at bridge abutments.

Prior to commencing any designs of other wall types as specified herein, the Contractor shall submit to SCDOT the wall type selected, design methodology, and design criteria for review. Design criteria shall include wall geometry and location, factors of safety, soil properties, and material properties of the wall. Shop plans shall be submitted in accordance with the Shop Plans section below.

Culverts

1. General

Culverts will not be allowed as a substitute for bridges specified in this project.

Culverts may be used on this project as a means of accommodating cross line drainage, if warranted by hydraulic design.

Culverts shall have four sides and shall be constructed of reinforced concrete.

Riprap is required at ends of box culverts and shall conform to details shown on the *SCDOT Standard Drawings*.

2. Materials

Class 4000 concrete (minimum) shall be used for cast-in-place elements of culverts and Class 5000 concrete (minimum) shall be used for precast elements of culverts.

Reinforcing bars shall conform to the requirements of ASTM A 706, Grade 60. Welded Wire Fabric shall meet the requirements of AASHTO M 55 or AASHTO M 221. The wire for the welded wire fabric shall meet the requirements of AASHTO M 32 or M 225, Grade 65

3. Design and Detailing Requirements

General

The length of the culvert shall be established so that, at the end of the culvert, the theoretical fill slope is 1 foot below the top of the top slab. Where practical, the culvert headwalls should be located outside of the adjusted clear zone (see *SCDOT Standard Drawing* No. 805-010-00) or the exposed portions of the structure should be appropriately shielded.

Weep holes and French drains shall be detailed in accordance with Section 702 of the *SCDOT Standard Specifications for Highway Construction*. The weep holes shall be located 12 inches above the normal water line.

For culverts that convey water, rip rap and geotextile fabric shall be detailed at both ends of the culvert in accordance with *SCDOT Standard Drawing* No. 804-205-00.

The maximum allowable settlement for a culvert is 8 inches from the beginning of construction until the end of the 75-year design life of the culvert. The maximum allowable differential settlement along the length of a culvert is limited to 1 inch per 50 feet of culvert length. During a seismic event, the maximum allowable differential settlement along the length of a culvert is also 1 inch per 50 feet of culvert length. If deep foundations are used to limit the settlement of a culvert, the longitudinal differential settlement shall be checked for the adjacent embankment and shall not exceed the longitudinal embankment performance limits provided in the *SCDOT Geotechnical Design Manual*.

Additional reinforcing steel shall be detailed at openings in the top slab or side walls to meet or exceed the reinforcement shown on *SCDOT Standard Drawing* No. 722-105-02.

In situations where guardrail or rigid barrier must be provided for protection and the installation would require attachment to the culvert, a moment slab shall be designed and detailed to eliminate transfer of moment to the culvert barrel. The moment slab may be attached to the culvert barrel for resistance to sliding forces; the connection must be designed and detailed to resist horizontal sliding forces only. Where site and culvert geometry permit, a 12'-6" long span nested guardrail shall be detailed to bypass the culvert as shown on *SCDOT Standard Drawing* No. 805-565-00.

All box culverts, whether cast-in-place or precast, shall be detailed with cast-in-place wing walls, head walls, aprons, and cut-off walls on both the inlet and outlet ends. Precast wing walls, head walls, aprons, cut-off walls, and footings are not permitted.

Wing Walls

Wing walls are typically flared out approximately 30 degrees in relation to the centerline of the culvert, but the angle may vary based on site conditions. The wing walls shall be detailed so that the top of the wing wall is at least 12 inches above the finished ground line. The wing wall height should be designed and detailed so that, at the junction of the wing wall and culvert barrel, the top of the wing wall is the same elevation as the top of the top slab of the culvert barrel. The wing wall may be terminated when the height is such that the soil can wrap around the exposed face of the wing wall, using a slope of 2H:1V or flatter, without encroaching on the projected barrel opening.

Wing walls may be supported by footings or aprons, but no support shall be assumed from the culvert barrel(s).

The thickness of wing walls shall be equal to or greater than the exterior wall thickness of the culvert. If the maximum wing wall height is greater than 5 feet and the wing wall has a layer of reinforcing in each face, a minimum of 5 inches of clearance shall be provided between the mats of reinforcing steel.

Aprons

For box culverts, aprons shall be detailed as continuously cast-in-place concrete placed from end to end of the wing walls. Aprons may cover the entire area between the wing walls and the ends of the culvert barrel(s) or may follow the edges of the wing wall/culvert barrel(s). The aprons may be designed to support the wing walls. The thickness of the aprons shall be equal to or greater than the thickness of the bottom slab unless the bottom slab thickness exceeds 12 inches. If the bottom slab thickness exceeds 12 inches, the apron thickness need not be greater than 12 inches unless required by design.

Cut-Off Walls

Cut-off walls shall be detailed with a minimum thickness of 10 inches. Cut-off walls shall be detailed to extend a minimum of 2 feet below the bottom of the bottom slab or apron or 2 feet below the 500 year scour line, whichever is greater. If cut-off walls are used as structural elements, appropriate reinforcement must be designed and detailed in the plans.

Head Walls

Head walls shall be detailed with a minimum height of 12 inches above the finished ground line and a minimum thickness of 12 inches. Head walls shall extend the full width of the culvert barrel(s).

The head walls shall be anchored to the top slabs of culverts with reinforcing steel that has been designed and detailed to resist overturning and sliding. Each face of the head wall shall be detailed with a minimum of 0.2 square inches of reinforcing steel per foot in each direction.

Concrete Cover

For cast-in-place box culverts, concrete cover to reinforcing shall be provided in accordance with the *AASHTO LRFD Bridge Design Specifications*. For W/C ratios that are less than or equal to 0.4, the concrete cover modification factor shall be taken as 1.0.

Precast box culverts shall have a minimum clear cover of 3 inches.

Cast-in-place Concrete Box Culverts

General

For culverts with skews greater than 25 degrees, the transverse reinforcing steel shall be designed and detailed perpendicular to the longitudinal reinforcing steel. For lesser skew angles, the transverse reinforcing steel may be designed and detailed parallel to the skew.

At the discontinuous edges of culvert barrel sections, edge beams shall be designed for the top and bottom slabs.

Slabs

Cast-in-place box culvert top and bottom slabs shall have a minimum thickness of 10 inches.

Walls

Cast-in-place box culvert walls shall be vertical and shall have a minimum thickness of 8 inches. If the vertical opening dimension of the culvert is greater than 5 feet, a minimum of 5 inches of clearance shall be provided between mats of reinforcing in the walls.

Construction Joints

The maximum pouring length of cast-in-place culvert barrel sections shall be limited to 70 feet. Keyed transverse construction joints must be detailed in the

barrel(s) as required to meet this limit. The longitudinal reinforcing steel shall be detailed continuous across the joint.

If the volume of cast-in-place concrete exceeds 225 yd³ in any pour, provide a pouring sequence on the plans. All concrete pours must be completed in less than 5 hours. If a pouring rate greater than 45 yd³/hr is needed, the plans shall indicate the required pouring rate.

A keyed construction joint shall be detailed in the walls, 4 inches above the top of the bottom slab. When the height of the wall, measured from the top of the bottom slab, is 8 feet or greater, a keyed construction joint shall also be detailed between the walls and top slab.

The plans shall specify that cast-in-place concrete in a completed pour must reach a minimum compressive strength of 3 ksi prior to placing new concrete. Allow a minimum 4-day interval between adjacent pours. Additionally, for bridge slabs, do not perform the subsequent pour until pour concrete strength reaches 3000 ksi.

Precast Concrete Box Culverts

General

Precast box culvert sections are not allowed if any of the following conditions exist:

- the design earth cover exceeds 20 feet,
- the design earth cover is less than 2 feet,
- the culvert will be used for pedestrian traffic.

Monolithically cast box culvert sections shall be specified. Precast concrete split box culvert sections are not permitted.

Design Requirements

Precast box culvert sections shall be designed in accordance with ASTM C 1577 with exception of the required minimum concrete cover of 3 inches. For precast culverts having design fill heights greater than 5 feet, the design fill height shall be rounded to the next higher 5 foot increment when using the tabulated design information from ASTM C 1577.

Detailing Requirements

Precast box culverts shall be detailed in accordance with *SCDOT Standard Drawing* No. 722-305-00 and Section 722 of the *SCDOT Standard Specifications for Highway Construction*. The plans shall require all precast box culverts to be placed on a prepared bed of aggregate (Coarse Aggregate No. 5, No. 56, or No. 57) having a minimum thickness of 6 inches. The aggregate bed must extend the entire width and length of the culvert plus 3 inches beyond the outer walls of the barrel(s).

The plans for precast box culverts shall include details for cast-in-place wing walls, head walls, aprons, cut-off walls, and footings. These cast-in-place elements shall comply with the requirements of the section above entitled “Design and Detailing Requirements” and shall be attached to the precast culvert barrel(s) using #6 (#19) adhesive anchors detailed at a maximum spacing of 18 inches in the exposed ends of the barrel(s). These elements shall be designed to be self supporting. The adhesive anchors are intended to control differential settlement only.

Where multiple precast box culvert barrels are placed side by side, the plans shall require a 3½ inch minimum and 6 inch maximum space between adjacent barrel sections. The plans shall require this space to be filled with flowable fill or cast-in-place concrete. If the space is filled with flowable fill, the plans shall require that, at both the upstream and downstream ends, the last 6 inches of space between the barrels (measured along the longitudinal direction of the barrels) be filled with a cast-in-place concrete cap for the full height of the barrels.

Plans Preparation

Culvert plans are typically included within a set of roadway plans and the sheets are numbered using an “S” prefix. The culvert plan sheets shall present the following information:

- a. Title Blocks. The title blocks of the culvert sheets shall include the fill height used to design the culvert, the culvert opening size (span x rise), the station at centerline of culvert, and the slope of fills.
- b. Location Sketch. A location sketch shall be provided that includes the following information and details:
 - proposed culvert outline,
 - existing culvert outline as a light, dashed line,
 - centerline of roadway,
 - direction of stationing,
 - station of intersection of roadway centerline and culvert centerline,
 - dimensions of culvert barrels,

- length of each end of culvert measured from the roadway centerline,
 - skew angle,
 - construction staging (if required),
 - temporary shoring locations (if required for construction),
 - permissible types of temporary shoring (if restricted),
 - stream name,
 - direction of flow,
 - limits of riprap or note that riprap shall be in accordance with *SCDOT Standard Drawing No. 804-205-00* (if required),
 - north arrow,
 - existing structures, features, utilities in vicinity of culvert if they impact culvert construction,
 - invert elevations at each end of new culvert or both ends of each side being extended,
 - top and bottom of footing elevations for floorless culverts,
 - boring locations, and
 - hydraulic data.
- c. Design Information. The design specification and live load shall be indicated in the plans. If shop plans will be required, the plans must include the shop plans submittal information (mailing address and telephone number of designer).
- d. Plan View. A plan view shall be provided that details the culvert, apron, cut-off wall, wing wall, and footing dimensions; the reinforcing bars, bar callouts, and bar spacing; and the location of any required transverse construction joints.
- e. Cross Section. Section views of the barrel(s), wing walls, head walls, aprons, cut-off walls, and footings shall be provided detailing the dimensions; the reinforcing bars, bar callouts, and bar spacing; the weep holes and french drains; and the location of construction joints.
- f. Reinforcing Steel Schedule and Quantities. For each culvert, include a reinforcing steel schedule that lists the reinforcing steel required for the culvert. The schedule shall include the mark, number of bars required, and dimensions for each reinforcing bar. Immediately below the reinforcing steel schedule, include a list of estimated quantities for the culvert. All quantities required for construction of the culvert (e.g., reinforcing steel, concrete, piling, temporary shoring, excavation, existing culvert removal, riprap, geotextile, etc.) shall be included. For projects

requiring stage construction, reinforcing steel and quantities must be broken down by stage.

- g. Boring Logs. Copies of the boring logs shall be included in the plans or proposal.

3. MISCELLANEOUS STRUCTURES

1. Fender System

A bridge fender system shall be constructed at the navigational channel. The fender system shall be independently supported and shall not be connected to the bridge piers or footings. The fender system shall be constructed of prestressed concrete piles, treated timber wales, and stainless steel hardware. The fender system shall be designed for dead load, wind load, and wave action impact. Sample fender system details are provided in Attachment B.

Submerged, damaged or hidden components of the current or previous fender systems shall be removed and disposed and shall not be considered a differing site condition. All costs associated with the new fender system shall be included in the Contractor's bid price.

~~The maintenance walkway on the fender system shall have a minimum width of 3' 6". Railings with toe boards shall be provided with a total height of 42" above walkway surface. Design and detailing of the fender system shall be in accordance with AASHTO requirements. Walkway should be accessible by boat from the Wando River and security gates shall be provided to limit access to unauthorized personnel.~~

~~Fender System shall be provided and designed as a rubbing system only. The system shall utilize long life materials (plastic plies and rubbing strips). Pier protection dolphin cluster piles shall be utilized to resist an upstream or downstream attack at the main channel piers only. Protection for other piers shall be in accordance with the requirements of the vessel collision analysis.~~

See *Navigational Lighting* Section for additional information and requirements.

2. Navigational Lighting

Navigation Lighting shall be provided on the fender piers and channel span as per AASHTO and United States Coast Guard (USCG) requirements.

See special provision titled *Navigation Lights for Bridge* in Exhibit 5 for additional requirements.

Navigational Channel

No obstructions are allowed in the navigational channel. The horizontal channel limits are depicted in the Preliminary Bridge plans developed by Triplett-King & Associates, File No. 8.158B, sheet numbers 2 and 3. The referenced bridge plans are contained in Attachment B. The navigational channel is aligned with the most western fender of the existing SC 41 Bridge as indicated in the referenced plans and continues for 90 feet in the direction of station. Any variation in the location of the navigational channel is subject to USGS USCG approval. Existing horizontal clearance must be maintained at the channel during construction to accommodate marine traffic.

Bridge Deck Drainage

Any necessary bridge deck drainage in the form of “off-bridge” inlet protection and “on-bridge” scuppers shall be provided. A closed drainage system will be required and the bridge drainage shall be designed in accordance with SCDOT requirements. Scuppers shall be connected to under deck collector pipes and the water shall be taken to a permanent water quality best management (BMP) device for treatment.

The appropriate design method shall be utilized depending on selection of rectangular or circular scuppers with downspouts. The scuppers shall be designed in a manner that allows integration into the bridge deck design and does not interfere with structural continuity. Surface grates and recessed collection chambers may be considered if structurally necessary. Inlets are to be sized as large as possible to allow for ease of maintenance. Inlet grates shall be designed for safe passage of bicycle traffic. Scuppers shall be a minimum of six inches in diameter (or equivalent cross sectional area).

Downspouts and collector pipes shall be fiberglass and shall be colored (not painted) to match the finished bridge color (Federal Color Standard No. 26600). Cleanouts shall be provided. No drains or discharge pipes shall be allowed inside of structural elements other than the bridge deck.

EXHIBIT 4b – STRUCTURES DESIGN CRITERIA

As a minimum, asphalt flumes shall be provided at the end of the approach slabs as required to prevent erosion of the bridge fill slope. Alternative drainage structures such as roadway catch basins shall be provided where asphalt flumes interfere with the closed system. Storm drainage pipes shall not be permitted under the approach slabs.

EXHIBIT 4c

PAVEMENT DESIGN CRITERIA

SC-41 and SC-41N Relocation

Construct an asphalt pavement for the travel lanes and shoulders. In areas of new construction, construct the pavement with the following structure:

200 psy Asphalt Surface Type B
200 psy Asphalt Intermediate Type B
850 psy Asphalt Base Type A

300 psy Asphalt Base Type A and 10 inches Graded Aggregate Base may be used in lieu of the 850 psy Asphalt Base Type A.

SC-41 and S-33

For widening of SC Rte. 41 and Secondary Rte. 33, mill the existing pavement 2 inches and overlay with at least 200 psy Asphalt Surface Type B. Construct widening on SC-41 and S-33 with the following structure:

200 psy Asphalt Surface Type B
200 psy Asphalt Intermediate Type B
850 psy Asphalt Base Type A

Use variable Asphalt Surface B for build-up and leveling of the existing roadway. 300 psy Asphalt Base Type A and 10 inches Graded Aggregate Base may be used in lieu of the 850 psy Asphalt Base Type A.

Local Roads

Construct new pavement with the following structure:

175 psy Asphalt Surface Type B
200 psy Asphalt Intermediate Type C
450 psy Asphalt Base Type B

EXHIBIT 4d - Part 1

SIGNING AND PAVEMENT MARKING DESIGN CRITERIA

(1) GENERAL PROVISIONS FOR PERMANENT PAVEMENT MARKINGS:

Pavement marking work on this project consists of preparing detailed pavement marking plans and providing and applying appropriate markings for the length of the project. All edge lines, lane lines, channelization markings, stopbars and word messages and symbols on SC 41 and all intersecting routes shall be of the width and patterns detailed in the Standard Drawings. The white edge lines may be 6 inches in width if sufficient shoulder width is present to allow for bicycle traffic. The final roadway surface material will determine which type of permanent marking material is to be applied. The Contractor shall use preformed tape (T-1) markings on all concrete bridge deck surfaces. Thermoplastic markings shall be used on all asphalt surfaces.

All work involved in this contract shall be in accordance with the following publications:

- The South Carolina “Standard Specifications for Highway Construction”, (latest edition) – referred to as the Standard Specifications
- The South Carolina “Standard Drawings for Road Construction”, (latest edition) – referred to as the Standard Drawings
- The Federal “Manual on Uniform Traffic Control Devices”, (latest edition) – referred to as the MUTCD.
- The Plans and these Special Provisions.

Pavement marking materials used shall meet the following requirements:

1. THERMOPLASTIC PAVEMENT MARKINGS (ASPHALT SURFACES):

All thermoplastic markings installed on the interstate mainline or any crossing routes shall meet the requirement of Section 627 of the Standard Specifications.

2. PREFORMED PATTERNED TAPE (T-1) PAVEMENT MARKINGS (CONCRETE SURFACES):

The markings applied to the concrete bridge decks on this project shall be pre-formed patterned tape with a raised diamond pattern covered with ceramic elements having a refractive index of 1.9 or greater. These markings shall be installed with a truck mounted application system or other motorized applicator approved by the manufacturer.

The Contractor shall provide to the Department the manufacturer’s normal warranty which shall guarantee the tape materials for a period of 72 months from the date of installation from failure to retain the minimum reflectance values provided by the manufacturer and from failure due to loss of material adhesion or complete wear through. If failure occurs, the manufacturer will provide the replacement materials to restore the markings to their original effectiveness.

(2) GENERAL PROVISIONS FOR PERMANENT SIGNING:

Signing work on this project consists of preparing detailed signing plans; and fabricating, furnishing, and erecting new ground mounted guide, regulatory and warning signs. New signs shall be erected over the entire length of the project, including, at a minimum, stop signs on all intersecting routes. Existing signs, if applicable, shall be maintained during construction.

Development of the signing plans should be coordinated through the District Traffic Engineer for Engineering District 6. The District Traffic Engineer shall have final approval of all signing plans.

All work involved in this contract shall be in accordance with the following publications:

- The South Carolina “Standard Specifications for Highway Construction”, (latest edition) – referred to as the Standard Specifications
- The South Carolina “Standard Drawings for Road Construction”, (latest edition) – referred to as the Standard Drawings
- The Federal “Manual on Uniform Traffic Control Devices”, (latest edition) – referred to as the MUTCD.
- The AASHTO “Standard Specifications for Structural Supports for Highway Signs, Luminaires and Traffic Signals”, (latest edition)
- The Plans and these Special Provisions.

EXHIBIT 4d - Part 2

WORK ZONE TRAFFIC CONTROL DESIGN CRITERIA

TRAFFIC CONTROL

The Contractor shall execute the item of Traffic Control as required by the Standard Specifications, the plans, the Standard Drawings For Road Construction, these special provisions, all supplemental specifications, the MUTCD, and the Engineer. This is an amendment to the Standard Specifications to require the following:

GENERAL REGULATIONS

These special provisions shall have priority to the plans and comply with the requirements of the MUTCD and the standard specifications. Revisions to the traffic control plan through modifications of the special provisions and the plans shall require approval by the department. Final acceptance of any revisions to the traffic control plan shall be pending upon review by the member of the Design-Build team representing the Director of Traffic Engineering through the Design-Review Process..

Install and utilize changeable message signs in all lane closures installed on high volume high-speed multilane roadways. Use of changeable message signs in lane closures installed on low volume low speed multilane roadways is optional unless otherwise directed by the plans and the Engineer. Install and use a changeable message sign within a lane closure set-up as directed by the *Standard Drawings For Road Construction*. When a lane closures is not present for any time to exceed 24 hours, remove the changeable message sign from the roadway. Place the sign in a predetermined area on the project site, as approved by the Engineer, where the sign is not visible to passing motorists. Utilize preprogrammed messages in accordance with the *Standard Drawings For Road Construction* when using the changeable message sign as part of the traffic control set-up for lane closures. Only those messages pertinent to the requirements of the traffic control situation and the traffic conditions are permitted for display on a changeable message sign at all times. At no time will the messages displayed on a changeable message sign duplicate the legends on the permanent construction signs.

During operation of changeable message signs, place the changeable message sign on the shoulder of the roadway no closer than 6 feet between the sign and the near edge of the adjacent travel lane. When the sign location is within 30’ of the near edge of a travel lane open to traffic, supplement the sign location with no less than 5 portable plastic drums placed between the sign and the adjacent travel lane for delineation of the sign location. Install and maintain the drums no closer than 3 feet from the near edge of the adjacent travel lane. This requirement for delineation of the sign location shall apply during all times the sign location is within 30’ of the near edge of a travel lane open to traffic, including times of operation and non-operation. Oversized cones are prohibited as a substitute for the portable plastic drums during this application.

All signs mounted on portable sign supports shall have a minimum mounting height of 5’ from the bottom of the sign to the ground. All signs mounted on ground mounted u-channel posts or square steel tube posts shall have a minimum mounting height of 7’ from the bottom of the sign to the grade elevation of the near edge of the adjacent travel lane or sidewalk when a sidewalk is present.

On multilane primary routes, avoid placement of signs mounted on portable sign supports within paved median areas utilized for two-way left turns unless otherwise directed by the RCE.

Temporary “Exit” signs (M1025-00) shall be located within each temporary gore during lane closures on multilane roadways. Mount these signs a minimum of 7’ from the pavement surface to the bottom of the sign in accordance with the requirements of the MUTCD.

When mounting signs on ground mounted u-section or square steel tube posts, utilize either a sign support / ground support post combination with an approved breakaway assembly or a single direct driven post for each individual sign support of a sign assembly installation. Do not combine a sign support / ground support post combination and a direct driven post on the same sign assembly installation that contains two or more sign supports. Regarding sign support / ground support post combination installations, ensure that post lengths, stub heights and breakaway assemblies comply with the manufacturer’s requirements and specifications. Use approved breakaway assemblies found on the *Approved Products List For Traffic Control Devices in Work Zones*.

When covering signs with opaque materials, the Department prohibits attaching a covering material to the face of the sign with tape or a similar product or any method that will leave a residue on the retroreflective sheeting. Residue from tape or similar products, as well as many methods utilized to remove such residue, damages the effective reflectivity of the sign. Therefore, contact of tape or a similar product with the retroreflective sheeting will require replacement of the sign. Cost for replacement of a sign damaged by improper covering methods will be considered incidental to providing and maintaining the sign; no additional payment will be made.

Overlays are prohibited on all rigid construction signs. The legends and borders on all rigid construction signs shall be either reversed screened or direct **applied**.

Signs not illustrated on the typical traffic control standard drawings designated for permanent construction signs shall be considered temporary and shall be included in the lump sum price bid item for “Traffic Control” unless otherwise specified.

Install “Grooved Pavement” signs (W8-15-48) supplemented with the “Motorcycle” plaque (W8-15P-30) in advance of milled or surface planed pavement surfaces. On primary routes, install these signs no further than 500 feet in advance of the beginning of the pavement condition. On interstate routes, install these signs no less than 500 feet in advance of the beginning of the pavement condition. Install two sign assemblies at each sign location, one on each side of the roadway, on multilane roadways when the pavement condition is present. Install these signs immediately upon creation of this pavement condition and maintain these signs until this pavement condition is eliminated.

Install “Steel Plate Ahead” signs (W8-24-48) in advance of an area of roadway where temporary steel plates are present. Install these signs no further than 300 feet in advance of locations where steel plates are present. On multilane roadways, comply with the same

EXHIBIT 4D – PART 2 WORK ZONE TRAFFIC CONTROL REQUIREMENTS

guidelines as applied to all other advance warning signs and install two sign assemblies at each sign location, one on each side of the roadway, when roadway conditions warrant. Install these signs immediately upon installation of a temporary steel plate and maintain the signs until the temporary steel plates are removed.

Install and maintain any necessary detour signing as specified by the typical traffic control standard drawings designated for detour signing, Part VI of the MUTCD, these Special Provisions, and the Engineer. The lump sum price bid item for “Traffic Control” includes payment for installation and maintenance of the detour signing.

The Contractor shall maintain the travel patterns as directed by the traffic control plans and shall execute construction schedules expeditiously. The Contractor shall provide the Resident Engineer with no less than a two-week prior notification of changes in traffic patterns.

During nighttime flagging operations, flaggers shall wear a safety vest and safety pants that comply with the requirements of ANSI / ISEA 107 standard performance for Class 3 risk exposure, latest revision, and a fluorescent hard hat. The safety vest and the safety pants shall be retroreflectorized and the color of the background material of the safety vest and safety pants shall be fluorescent orange-red or fluorescent yellow-green.

During nighttime flagging operations, the contractor shall illuminate each flagger station with any combination of portable lights, standard electric lights, existing street lights, etc., that will provide a minimum illumination level of 108 Lx or 10 fc.

During nighttime flagging operations, supplement the array of advance warning signs with a changeable message sign for each approach. These changeable message signs are not required during daytime flagging operations. Install the changeable message signs 500’ in advance of the advance warning sign arrays. Messages should be “Flagger Ahead” and “Prepare To Stop”.

During the paving operations, the length of roadway with an acceptable grade elevation difference less than or equal to 2" shall be restricted to 4 miles.

During the milling and surface planing operations, the length of roadway with an acceptable grade elevation difference less than or equal to 1" shall be restricted to 4 miles.

During construction on the ramps, the contractor shall conduct flagging operations. The flagging operations shall either stop traffic or direct the traffic around the work area. Installation and operation of these flagging operations shall be according to these special provisions and the MUTCD.

Supplement and delineate the shoulder edges of travel lanes through work zones with traffic control devices to provide motorists with a clear and positive travel path. Utilize portable plastic drums unless otherwise directed by the Department. Vertical panels may be used where specified by the plans and directed by the RCE. The installation of traffic control devices are required in all areas where those areas immediately adjacent to a travel lane open to traffic have been altered in any manner by work activities, including but not limited to activities such as

grading, milling, etc. Install the traffic control devices immediately upon initiating any alterations to the areas immediately adjacent to or within 15 feet of the near edge line of the adjacent travel lane. When sufficient space is available, place the traffic control devices no closer than 3 feet from the near edge of the traffic control device to the near edge line on the adjacent travel lane. When sufficient space is unavailable, place the traffic control device at the maximum distance from the near edge of the adjacent travel lane available.

LANE CLOSURE RESTRICTIONS

The lane closure restrictions stated below are project specific, for all other restrictions, see supplemental specification, “Restrictions”, dated January 3, 2013.

The Contractor shall install all lane closures as directed by the 2007 Standard Specifications For Highway Construction, the Standard Drawings For Road Construction, these special provisions, the MUTCD, and the Engineer. The Contractor shall close the travel lanes of two-lane two-way roadways by installing flagging operations. The Contractor shall close the travel lanes of multilane roadways as directed by the typical traffic control standard drawings designated for lane closures on primary routes.

The Department prohibits lane closures on primary routes during any time of the day that traffic volumes exceed 800 vehicles per hour per direction. The Department reserves the right to suspend a lane closure if any resulting traffic backups are deemed excessive by the Engineer. Maintain all lane closure restrictions as directed by the plans, these special provisions, and the Engineer.

Flagging operations are considered to be lane closures for two-lane two-way operations and shall be subject to all restrictions for lane closures as specified by this contract.

Lane closures, including flagging operations, are restricted to maximum distances of 2 miles. Install all lane closures according to the typical traffic control standard drawings. On occasions when daytime lane closures must be extended into the nighttime hours, substitute the nighttime lane closure standards for the daytime lane closure standards.

The Department reserves the right to suspend a lane closure if any resulting traffic backups are deemed excessive by the Engineer. Maintain all lane closure restrictions as directed by the Standard Specifications, these special provisions, and the Engineer.

Installation and maintenance of a lane closure is PROHIBITED when the Contractor is not actively engaged in work activities specific to the location of the lane closure unless otherwise specified and approved by the Engineer. The length of the lane closure shall not exceed the length of roadway anticipated to be subjected to the proposed work activities within the work shift time frame or the maximum lane closure length specified unless otherwise approved by the Engineer. Also, the maximum lane closure length specified does not warrant installation of the specified lane closure length when the length of the lane closure necessary for conducting the work activity is less. The length and duration of each lane closure, within the specified parameters, shall require approval by the Engineer prior to installation. The length and

duration of each lane closure may be reduced by the Engineer if the work zone impacts generated by a lane closure are deemed excessive or unnecessary.

The presence of temporary signs, portable sign supports, traffic control devices, trailer mounted equipment, truck mounted equipment, vehicles and vehicles with trailers relative to the installation or removal of a closure and personnel are prohibited within the 15 to 30 foot clear zone based upon the roadway speed limit during the prohibitive hours for lane closures specified by these special provisions.

SHOULDER CLOSURE RESTRICTIONS

The Department prohibits the Contractor from conducting work within 15' of the near edge of the adjacent travel lane on the outside shoulders or the median areas under a shoulder closure during any time of the day that traffic volumes exceed 800 vehicles per hour per direction. The hourly restrictions for lane closures shall also apply to work activities conducted under a shoulder closure within 15' of the near edge of an adjacent travel lane or a median area. The Department reserves the right to suspend work conducted under a shoulder closure if any traffic backups develop and are deemed excessive by the Engineer. Maintain all shoulder closure restrictions as directed by the plans, these special provisions, and the Engineer.

On primary and secondary roadways, the Department prohibits the Contractor from conducting work within 1' or less of the near edge of an adjacent travel lane under a shoulder closure. All work that may require the presence of personnel, tools, equipment, materials, vehicles, etc., within 1' of the near edge of an adjacent travel lane shall be conducted under a lane closure.

The Contractor shall install all shoulder closures as directed by the typical traffic control standard drawings designated for shoulder closures, and the Engineer. Substitution of the portable plastic drums with oversized cones during nighttime shoulder closures is PROHIBITED.

TYPICAL TRAFFIC CONTROL STANDARD DRAWINGS

The typical traffic control standard drawings of the "Standard Drawings For Road Construction", although compliant with the MUTCD, shall take precedence over the MUTCD. The typical traffic control standard drawings of the "Standard Drawings For Road Construction" shall apply to all projects let to contract.

ADDENDUMS

(Addendums to the "2007 Standard Specifications for Highway Construction")

(A) **Construction** (Sub-section 601.4)

Sub-section 601.4.2 Construction Vehicles (paragraph 2)

When working within the rights-of-way of access-controlled roadways such as Interstate highways, the Contractor's vehicles may only change direction of travel at interchanges. These vehicles are prohibited from crossing the roadway from right side to median or vice versa. Use a flagger to control the Contractor's vehicles when these vehicles attempt to enter the roadway from a closed lane or the median area. Ensure that the flagger does not stop traffic, cause traffic to change lanes, or affect traffic in any manner. The Contractor's vehicles may not disrupt the normal flow of traffic or enter the travel lane of the roadway until a sufficient gap is present.

The Contractor shall have flaggers available to control all construction vehicles entering or crossing the travel lanes of secondary and primary routes. The RCE shall determine the necessity of these flaggers for control of these construction vehicles. The RCE shall consider sight distance, vertical and horizontal curves of the roadway, prevailing speeds of traffic, frequency of construction vehicles entering or crossing the roadway, and other site conditions that may impact the safety of the workers and motorists when determining the necessity of these flaggers. Ensure that these flaggers do not stop traffic, cause traffic to change lanes, or affect traffic in any manner. The Contractor's vehicles may not disrupt the normal flow of traffic or enter the travel lane of the roadway until a sufficient gap is present.

(B) **Construction** (Sub-section 601.4)

Sub-section 601.4.2 Construction Vehicles

Auxiliary Warning Lights for Vehicles and Equipment

Supplement all construction and/or construction-related vehicles and equipment that operate in a stationary or mobile work zone within or adjacent to a roadway within the highway rights-of-way with AMBER or YELLOW colored high intensity rotating or strobe type flashing auxiliary warning light devices. Utilize, install, operate and maintain a single or multiple lighting devices as necessary to provide visibility to approaching motorists.

All auxiliary warning light models shall meet *Society of Automotive Engineers* (SAE) Class I standards and SAE Standard J575 relative to *Tests for Motor Vehicle Lighting Devices and Components* and these specifications.

The amber/yellow color of the dome/lens of an auxiliary warning light device shall meet SAE Standard J578 for amber/yellow color specifications.

Auxiliary warning lights with parabolic reflectors that rotate shall rotate around a halogen lamp at a rate to produce approximately 175 flashes per minute. The parabolic reflector shall produce a minimum 80,000 candle power and a minimum 54,000 candela through an SAE Standard J846 approved amber dome.

Equip strobe type flashing auxiliary warning light devices with photosensitive circuit controls to adjust the lighting intensity in response to changes in ambient light conditions such as from day to night. These lights shall have a double-flash capability rated at approximately 80 double flashes per minute and produce a minimum 24 joules of flash energy at the highest power level setting.

Acceptable auxiliary warning light models shall provide sufficient light output to be clearly recognizable at a minimum distance of 1750 feet.

Mount all auxiliary warning light devices intended to function as the auxiliary warning light system or as an element thereof on vehicles and equipment at locations no less than 3 feet above the ground and in conspicuous locations to provide visibility to approaching motorists.

Auxiliary warning light devices and/or models that mount in the locations of the standard vehicle lighting system are unacceptable as the specified auxiliary warning light system due to restrictive simultaneous visibility capabilities from multiple sight angles. However, auxiliary warning light devices that mount in the standard vehicle lighting system locations are acceptable as supplements to the specified lighting devices mounted in locations that do meet the minimum height requirements and provide simultaneous visibility capabilities from multiple sight angles.

Standard vehicle hazard warning lights are only permitted as supplements to the specified auxiliary warning light devices.

(C) **Category I Traffic Control Devices (Section 603)**

*** *(Effective on all projects let to contract after May 1, 2010)* ***

Sub-section 603.2.2 Oversized Traffic Cones (paragraph 6)

Reflectorize each oversized traffic cone with 4 retroreflective bands: 2 orange and 2 white retroreflective bands. Alternate the orange and white retroreflective bands, with the top band always being orange. Make each retroreflective band not less than 6 inches wide. Utilize Type III – Microprismatic retroreflective sheeting for retroreflectorization on all projects let to contract after May 1, 2010 unless otherwise specified. Separate each retroreflective band with not more than a 2-inch non-reflectorized area. Do not splice the retroreflective sheeting to create the 6-inch retroreflective bands. Apply the retroreflective sheeting directly to the cone surface. Do not apply the retroreflective sheeting over a pre-existing layer of retroreflective sheeting.

Sub-section 603.2.3 Portable Plastic Drums (paragraph 3)

Reflectorize each drum with Type III – Microprismatic retroreflective sheeting: 2 orange and 2 white retroreflective bands, 6 inches wide on all projects let to contract after May 1, 2010 unless otherwise specified. Alternate the orange and white retroreflective bands with the top band always being orange. Ensure that any non-reflectorized area between the orange and white

retroreflective bands does not exceed 2 inches. Do not splice the retroreflective sheeting to create the 6-inch retroreflective bands. Apply the retroreflective sheeting directly to the drum surface. Do not apply the retroreflective sheeting over a pre-existing layer of retroreflective sheeting.

(D) **Category II Traffic Control Devices (Section 604)**

*** *(Effective on all projects let to contract after May 1, 2012)* ***

Sub-section 604.2.1 Type I and Type II Barricades (paragraph 3)

Reflectorize these barricades with Type VIII or IX Prismatic retroreflective sheeting on all projects let to contract after May 1, 2012 unless otherwise specified. Ensure that the retroreflective sheeting has alternate orange and white stripes sloping downward at a 45-degree angle in the direction of passing traffic. The stripes shall be 6 inches wide.

Sub-section 604.2.2 Type III Barricades (paragraph 3)

Reflectorize these barricades with Type VIII or IX Prismatic retroreflective sheeting on all projects let to contract after May 1, 2012 unless otherwise specified. Ensure that the retroreflective sheeting has alternate orange and white stripes sloping downward at a 45-degree angle. Apply the sloping orange and white stripes in accordance with the requirements of the Plans, SCDOT Standard Drawings and the MUTCD. The stripes shall be 6 inches wide.

(E) **Temporary Concrete Barrier (Sub-section 605.2.3.2)**

Sub-section 605.2.3.2 Temporary Concrete Barrier (paragraph 6)

Previously used temporary concrete barrier walls are subject to inspection and approval by the RCE before use. Ensure that previously used temporary concrete barrier walls are in good condition. Defects to a temporary concrete barrier wall that may disqualify a section of wall for use include gouges, cracks, chipped, or spalled areas. A defect that exposes reinforcing steel warrants immediate disqualification. A disqualification grade type defect shall consist of measurements in excess of 1 inch, entirely or partially within the boundaries of the end connection areas and the drainage slot areas as illustrated in the “Standard Drawings for Road Construction”, and/or in excess of 4 inches for all areas beyond the end connection areas. To warrant disqualification, these measurements shall exceed the specified dimensions in all three directions, width, height, and depth. A defect that exceeds the specified dimensions in only one or two of the three directions does not warrant disqualification.

Temporary concrete barrier walls with defects less than 6 inches in all three directions, width, height, and depth that do not expose reinforcing steel may be repaired in accordance with

the following requirements. Repair is prohibited on temporary concrete barrier walls with defects 6 inches or greater in all three directions, width, height, and depth.

For repair of temporary concrete barrier walls with defects less than 6 inches in all three directions, width, height, and depth that do not expose reinforcing steel, repair the defect with a premanufactured patching material specifically fabricated for patching structural concrete. The strength of the patch must meet or exceed the design strength of the class 3000 concrete of the temporary concrete barrier wall. Perform the repair procedures in accordance with all requirements and instructions from the manufacturer of the patch material. Use a bonding compound between the patch material and the concrete unless specifically stated by the manufacturer that a bonding compound is not required. If the manufacturer states that application of a bonding compound is optional, SCDOT requires application of a bonding compound compatible with the patch material. If cracking occurs within the patched area, remove the patch material completely and repeat the repair process. The contractor shall submit documentation stating all repairs have been conducted in accordance with these requirements prior to installing any temporary concrete barrier walls with repairs. Utilization of temporary concrete barrier walls with repairs shall require approval by the RCE prior to installation.

The Contractor shall submit certification documents for the patch material utilized for repairs to the Engineer prior to placing temporary concrete barrier walls that have been repaired on the project site.

(F) Truck-Mounted Attenuator (Sub-section 605.4.2.2)

Sub-section 605.2.2.2.3.3 Color (paragraph 1)

Use industrial grade enamel paint for cover of the metal aspects of the unit. Provide and attach supplemental striping to the rear face of the unit with a minimum Type III high intensity retroreflective sheeting unless otherwise directed by the Department. Utilize an alternating 4 to 8 inch black and 4 to 8 inch yellow 45-degree striping pattern that forms an inverted “V” at the center of the unit that slopes down and to the sides of the unit in both directions from the center.

(G) Truck-Mounted Attenuator (Sub-section 605.4.2.2)

Sub-section 605.4.2.2 Truck-Mounted Attenuators (paragraph 6)

Attach each truck-mounted attenuator to the rear of a truck with a minimum gross vehicular weight (GVW) of 15,000 pounds (actual weight). If the addition of supplemental weight to the vehicle as ballast is necessary, contain the material within a structure constructed of steel. Construct this steel structure to have a minimum of four sides and a bottom to contain the ballast material in its entirety. A top is optional. Bolt this structure to the frame of the truck. Utilize a sufficient number of fasteners for attachment of the steel structure to the frame of the truck to ensure the structure will not part from the frame of the truck during an impact upon the attached truck mounted attenuator. Utilize either dry loose sand or steel reinforced concrete for ballast material within the steel structure to achieve the necessary weight. The ballast material

shall remain contained within the confines of the steel structure and shall not protrude from the steel structure in any manner.

(H) Trailer-Mounted Changeable Message Signs (Sub-section 606.3.2)

Sub-section 606.5 Measurement (paragraph 2)

Trailer-mounted changeable message signs are included in the lump sum item for Traffic Control in accordance with **Subsections 107.12** and **601.5** of the “2007 Standard Specifications for Highway Construction”. No separate measurement will be made for trailer-mounted changeable message signs unless the contract includes a specific pay item for trailer-mounted changeable message signs.

The Contractor shall provide, install, operate, and maintain the trailer-mounted changeable message sign per traffic control set-up as directed by the Plans, the “Standard Drawings for Road Construction”, these Special Provisions, the Specifications, and the Engineer.

Sub-section 606.6 Payment (paragraph 2)

In addition to **Subsections 107.12** and **601.6**, the payment for Traffic Control is full compensation for providing, installing, removing, relocating, operating, and maintaining trailer-mounted advance warning arrow panels and trailer-mounted changeable message signs as specified or directed and includes providing the units’ primary power source; repairing or replacing damaged or malfunctioning units within the specified time; providing traffic control necessary for installing, operating, and maintaining the units; and all other materials, labor, hardware, equipment, tools, supplies, transportation, incidentals, and any miscellaneous items necessary to fulfill the requirements of the pay item in accordance with the Plans, the Specifications, and other items of the Contract.

Sub-section 606.6 Payment (paragraph 3)

Disregard this paragraph unless the Contract includes a specific pay item for trailer-mounted changeable message signs.

(I) Flagging Operations (Sub-section 610.4.1)

Sub-section 610.4.1.1 Flagging Operations (paragraph 1)

Use a flagging operation to control the flow of traffic when two opposing directions of traffic must share a common travel lane. A flagging operation may be necessary during a lane closure on a two-lane two-way roadway, an intermittent ramp closure or an intermittent encroachment of equipment onto a portion of the roadway. Utilize flagging operations to direct traffic around work activities and maintain continuous traffic flow at reduced speeds when determined to be appropriate by the RCE. As stated above, flagging operations shall direct traffic around the work activities and maintain continuous traffic flow, therefore, stopped traffic

shall not be required to stop for time durations greater than those listed below unless otherwise directed by the RCE.

LENGTH OF CLOSURE	MAXIMUM TIME DURATION FOR STOPPED TRAFFIC
1 MILE or LESS	5 Minutes
1 to 2 MILES	7 ½ Minutes

If the work activities require traffic to be stopped for periods greater than 5 to 7 ½ minutes as stated above, consider alternate work methods, conducting work activities during times of lowest traffic volumes such as during the hours of darkness or complete road closure with detour installation.

(J) Paving and Resurfacing (Sub-section 611.4.1)

Sub-section 611.4.1.2 Requirements (paragraph 8)

Whenever travel lanes with acceptable grade elevation differences are open to traffic, provide “Uneven Lanes” signs (W8-11-48) or “Uneven Pavement” signs (W8-11A-48). Reflectorize these signs with a fluorescent orange colored prismatic retroreflective sheeting unless otherwise specified. Install these signs adjacent to roadways with uneven pavement surfaces between travel lanes or between travel lanes and the adjacent paved shoulders. Install these signs at intervals no greater than 2600 feet.

STAGING

TRAFFIC CONTROL RESTRICTIONS (Project Specific)

~~All construction and work vehicles over six tires shall enter and exit a right shoulder or median work area during the presence of lane closures. At no time will these vehicles be permitted to enter and exit these work areas without the presence of active lane closures. Shoulder closures are unacceptable and insufficient methods for control of traffic at ingress / egress areas for these vehicles.~~

The presence of acceptable grade elevation differences less or equal to 1” in milled areas or less than or equal to 2” in paved areas adjacent to a travel lane open to traffic are prohibited during weekends from 8:00 am Friday to 9:00 pm Sunday unless otherwise directed by the

Engineer. When necessary, the weekend restriction may be extended due to the proximity of a holiday as directed by the Engineer.

During surface planing and milling operations, the length of roadway with a milled surface open to traffic is restricted to 4 miles. This restriction does not apply to concrete diamond grinding operations.

During surface planing and milling operations, the length of roadway with an acceptable grade elevation difference less than or equal to 1” adjacent to a single travel lane or between multiple travel lanes open to traffic is restricted to a maximum distance of 4 miles.

During asphalt paving operations, the Contractor may conduct these work activities under lane closures with lengths up to but not greater than 4 miles. The Contractor shall comply with the 3 mile length restriction for lane closures for all work activities other than the asphalt paving operations.

During asphalt paving operations, the length of roadway with an acceptable grade elevation difference less than or equal to 2" adjacent to a single travel lane or between multiple travel lanes open to traffic is restricted to a maximum distance of 4 miles.

The Contractor may conduct various work activities in the same direction at various locations concurrently if approved by the Engineer. Various work activities in the same direction requiring simultaneous closures in the same travel lane or shoulder shall be separated by no less than 2 miles from the end of the first closure that a motorist will encounter to the beginning of the taper of the second closure. Also, various work activities in the same direction requiring simultaneous right and left lane closures or shoulder closures shall be separated by no less than 4 miles from the end of the first closure that a motorist will encounter to the beginning of the taper of the second closure.

EXHIBIT 4d - Part 3

TRAFFIC SIGNAL DESIGN CRITERIA

TRAFFIC CONTROL DEVICES: The Contractor shall design traffic control devices (including signals) for the subject location (see Scope). The design and implementation shall be in accordance with the MUTCD (Latest Edition) and SCDOT's Traffic Signal Design Guidelines (latest revision), Standard Specifications for Highways Construction (latest edition) and Traffic Signal Installation-Special Provisions (latest revision).

All signal installations shall utilize steel or concrete strain poles conforming to the Special Provisions.

Permanent Signals Design:

Development of Signal Design: The design and implementation shall be in accordance with the MUTCD (Latest Edition) and SCDOT's Traffic Signal Design Guidelines (latest revision). As part of the signal design, signal phasing should be coordinated with the appropriate District Traffic Engineer to decide the appropriate signal phasing for the intersection based on traffic patterns, develop clearance times (yellow and all-red) for various phases and complete various charts and tables associated with the signal design like loop chart, coordination chart, phasing diagram etc.

To determine the appropriate left turn phasing, Contractor shall use standard traffic engineering's crossproduct formula.

Software for the Signal Design: The signal design shall be developed using Microstation software (version, per the SCDOT specifications).

Signal Design Deliverables: One set of sealed signal plans and the Microstation .dgn files shall be provided to the appropriate District Traffic Engineer for review. All backgrounds should be inherent in the file without having reference files.

Signal Timing Plans:

Development of Signal Timing Plans: The Contractor shall develop signal timing for the intersection. The intersection should be studied to determine appropriate signal phasing, left turn sequence (lead or lag), and appropriate cycle lengths. Main objective of the signal timing is to develop a signal timing to reduce delays and improve capacity.

Cycle lengths, offsets, splits for various phases offset reference phases etc., shall be developed using Synchro Software

Software for the Signal Design: Traffic engineering standard software Synchro (developed by Trafficware) shall be used to develop signal timing.

EXHIBIT 4e

HYDRAULIC DESIGN CRITERIA

a) HYDROLOGY AND HYDRAULIC DESIGN

The CONTRACTOR will develop hydrologic and hydraulic designs for the bridge and follow all guidelines for roadway surface drainage and sediment and erosion control with the methods, procedures, and criteria outlined in the “SCDOT Requirements for Hydraulic Design Studies”, May 26, 2009, and all pertinent Design References located in Exhibit 4, Project Design Criteria.

At a minimum, all bridges shall maintain the existing bridge low chord, exceed the length and opening of the existing bridge, and span the main channel unless otherwise noted in the Project Design Criteria in Exhibit 4B. See attached study report for the Wando River performed by Ayres Associates dated June 13, 2011, ~~to be used for the hydraulic modeling.~~ The contractor has the option to either utilize and update this provided model to analyze a fixed span bridge or to develop their own independent 1D unsteady model to analyze the fixed span bridge. If the contractor chooses to utilize the Ayres Associates model then they must verify that the data in the model is valid. All of the data that the contractor utilizes for the hydraulic analysis must be referenced in a signed and sealed Bridge Hydrology and Hydraulics Report.

b) HYDRAULIC MODELING

The CONTRACTOR will utilize a study of the hydrologic/hydraulic characteristics of the existing and proposed bridge supplied by the Department. The CONTRACTOR will determine the beginning and end stations, finished grade elevations and optimal span configurations for the new bridge based on this study. The CONTRACTOR will present a summary of their data collection, findings and proposed design procedure to the DEPARTMENT for review and comment prior to finalizing the design. All hydraulic studies shall be approved by the DEPARTMENT.

A FEMA “No-Impact” Certification for a Coastal Zone AE is required. ~~New mapping from FEMA will not alter this requirement as described herein.~~ The CONTRACTOR will prepare and submit all required data to the local community for their records. Required data consists of a signed and sealed “No-Impact” letter stating that the bridge is insignificant in the transect modeling; therefore, no FEMA model will be submitted for review. Inform FEMA that an independent study has been conducted that details the bridge replacement. The letter should reference:

- The bridge lies within a coastal zone AE
- The proposed bridge will not cause any increase in flood heights or flooding potential for the surrounding areas during a 100 year coastal storm event
- The coastal modeling performed by FEMA for this area aligned the transects based on the topography, vegetation, and cultural development of the region and considered various storm characteristics to complete the model; therefore, a bridge replacement is insignificant when compared to the overall topography between these transects.
- Unsteady hydraulic modeling was performed for the bridge replacement and when the model containing no bridge obstructions is compared to the model containing the

proposed bridge no impacts were shown to surrounding structures due mostly to the vast flooding that occurs in this area during a hurricane storm surge event.

Provide to the Department a copy of the hydraulic study and the FEMA “No-Impact” Certification for a Coastal Zone AE letter that was submitted to the local community.

The bridge configuration must be set based on the triple profile which generally consists of cross sections cut 30’ left and right of the proposed centerline and one at the proposed centerline. However the location of the offset cross sections shall be adjusted to best reflect stream alignment (i.e. more or less than 30 feet left and/or right) but excludes the existing roadway fill limits. No proposed fill can project into the channel. This means that even if the 2:1 slope intersects with natural ground prior to the channel the slope must be projected through the ground line to an elevation below the bottom of the channel. This projection must not cross through either the offset or the centerline plot of the channel (triple profile).

The edge of the proposed piles, shaft, columns, or piers should be 5’ or more from the top of creek banks (channel overbanks).

c) DRAINAGE DESIGN

All closed storm drainage systems required for roadway drainage will be designed using the Geopak Drainage software. The design storm event and inlet spacing will be determined in accordance with the “SCDOT Requirements for Hydraulic Design Studies”, May 26, 2009.

All open channel drainage systems will be designed in accordance with the “SCDOT Requirements for Hydraulic Design Studies”, May 26, 2009.

The proposed bridge width was set to account for future additional travel lanes. Bridge deck drainage design must take into account the future shoulder width to ensure spread criteria is not violated when the bridge is restriped to account for the additional travel lanes across the bridge. The maximum shoulder width to be used for spread calculations for this bridge is 1' 6" and not 8' as per the current proposed typical.

d) NPDES STUDY AND SCDHEC NOI

The CONTRACTOR will provide the stormwater management study and sediment and erosion control plans in the manner and form prescribed in the “SCDOT Requirements for Hydraulic Design Studies” dated May 26, 2009, as stated in section a) Hydrology and Hydraulic Design. The CONTRACTOR shall provide the Erosion Control Data Sheet.

If permanent water quality best management practices (BMPs) pertaining to the treatment of stormwater from this project are necessary and a Manufactured Treatment Device is selected as the BMP, reference the Supplemental Technical Specification for Stormwater Manufactured Treatment Devices (MTDs) to obtain the variables for the determination of the water quality storm discharge. Due to DHEC 401 permit regulations, bridge deck drainage cannot discharge directly into the river before treatment.

The CONTRACTOR shall cross-check the water bodies for this project with SC DHEC’s most current 303(d) list and table for water bodies with approved TMDL’s to see if this

receiving stream(s) has either an approved TMDL or a soon-to-be TMDL target date. If listed, the CONTRACTOR shall provide the necessary best management practices to bring the project in conformance with SC DHEC requirements. This process should also be updated prior to construction.

The CONTRACTOR will prepare and submit to the Department a permit package for the land disturbing activities associated with this project. The package will consist of a completed SC Department of Health and Environmental Control (SCDHEC) Notice of Intent (NOI) form (most recently approved) stating that the Department is the owner/operator along with all applicable documentation required as part of the permit, including a Stormwater Pollution Prevention Plan (SWPPP). The SWPPP preparer section of the NOI shall be signed in blue ink. If the Coastal Zone Consistency (CZC) permit has not been approved it shall be forwarded by the CONTRACTOR to the Department to submit to SCDHEC as part of the NOI package.

e) SCOUR STUDY

The CONTRACTOR shall perform the scour analysis for these bridges in accordance with FHWA’s HEC-18, HEC-20, the Department’s guidelines. ~~and, if necessary at the Department’s discretion design and prepare plans for remedial measures, which may include structural modification and/or channel stabilization measures per FHWA’s HEC 23.~~ The CONTRACTOR will provide 100-year and 500-year scour profile information for the bridge using data developed by the HEC-RAS model. The 100-year and 500-year scour will be plotted to scale on the Triple Profile.

f) FINAL DRAINAGE REPORT

The CONTRACTOR will present a detailed study of the drainage to the Department. All final report, plans, drawings, calculation, etc. shall meet the approval of the Department prior to acceptance of the work. The Consultant will provide a design study report, signed and sealed by a professional engineer licensed in South Carolina, which includes the hydrologic and hydraulic design and scour analyses for the bridge, FEMA “No-Impact” Certification letter, roadway surface drainage design, NPDES studies, TMDL information, Stormwater Management Study and sediment and erosion control recommendations and designs. All design calculations, field notes, drawing, reports and other material prepared under this agreement will be the property of the Department and will be turned over to the Department upon completion of the work.

g) DELIVERABLES

The CONTRACTOR shall provide the following to the Department with the Preliminary Plans:

- ~~One (1)~~ Four (4) copy of the Hydraulic Design Calculations

The CONTRACTOR shall provide the following to the Department with the Final Plans:

EXHIBIT 4e – HYDRAULIC DESIGN CRITERIA

- Four (4) ~~One (1)~~ signed, completed copy (most recently approved) of the SCDHEC Notice of Intent (NOI),
- Four (4) ~~One (1)~~ completed CZC package, if applicable,
- Four (4) copies of the Bridge Hydrology and Hydraulic Report,
- Four (4) ~~Two (2)~~ copies of the Final Drainage Report and Stormwater Management Report, and
- Four (4) ~~One (1)~~ complete “No-Impact” Certification.
- Electronic copy of each submittal

EXHIBIT 4f

GEOTECHNICAL DESIGN CRITERIA

1. PROJECT SPECIFIC REQUIREMENTS

DYNAMIC LOAD TESTING WITH PILE DRIVING ANALYZER AND STATIC LOAD TESTING

The CONTRACTOR shall be responsible for the testing of all foundations used on this project. If driven piles are used, PDA testing in the form of a pile index program shall be performed. The CONTRACTOR shall provide a Pile Installation Plan (PIP) that shall include the pile index testing program. The pile index testing program shall at a minimum include the Bent and Pile number of each pile to be tested as well as the number of index piles to be tested. The number of index piles shall conform to the SCDOT Geotechnical Design Manual (GDM).

If drilled shafts are used, a non-production drilled shaft shall be tested prior to the design and construction of any production drilled shafts. The testing shall consist of either a static load test (bi-directional Osterberg Cell), a rapid load test (Statnamic), or a high-strain load test (Apple). The CONTRACTOR shall provide a Drilled Foundation Installation Plan (DFIP) that shall also include which load test procedure will be used (i.e. static, rapid, or high strain). The number of load tests shall conform to the requirements of the latest version of the GDM. The test shaft shall have a minimum diameter of 48 inches. The test shaft shall be located at least 25 feet from any existing bridge foundation and shall be positioned such that construction and testing operations do not adversely affect the existing bridge. In addition, the test shaft shall be located a minimum of 25 feet and a maximum of 50 feet from any future bridge drilled shaft foundation location. The location shall avoid conflicts with any construction staging, necessary work trestle, and/or utilities.

All testing reports whether for driven piles or drilled shafts shall bear the legible seal, signature and date of the testing firm's engineer, who shall be registered as a Professional Engineering in the State of South Carolina. The CONTRACTOR'S designer shall review and approve, in writing, all load test reports prior to submitting the reports to SCDOT for review and acceptance or comment. Comments made by SCDOT shall be reviewed and rectified by the CONTRACTOR'S designer prior to the results of the load testing be used in design.

GEOTECHNICAL DESIGN

The following F&ME reports have been provided in Attachment B for geotechnical information.

1. Report of Preliminary Analysis dated October 7, 2004
2. Report of Field Investigation and MSE Wall Feasibility Study dated April 22, 2005
3. Geophysical Investigation Report dated August 16, 2011
4. Addendum to Geotechnical Baseline Report dated August 26, 2011
5. Revised Geotechnical Baseline Report dated December 16, 2011
6. Site-Specific Seismic Response Analysis Final Report dated January 23, 2012

In addition to the aforementioned geotechnical reports, EXCEL spreadsheets of the cone penetration test and shear wave velocity data along with jpeg files of the electrical resistivity data have been provided in Attachment B. It shall be noted that SPT energy ratios were not measured for Borings B-1 to B-4 of the Report of Preliminary Analysis. The stations, offsets, and elevations for these same borings are as outlined in the Soil Test Location Schedule - Bridge of the Revised Geotechnical Baseline Report. Any location information for these borings other than what is outlined in this table shall be considered incorrect. All test holes presented in the attached reports are referenced from proposed centerline. In addition to the test holes completed to date, soil test borings B1-1 to B17-1 were previously proposed by Triplett-King & Associates, Inc. on Sheet 12 of Preliminary Bridge plans dated June 16, 2008; however, these test holes have not been performed.

All geotechnical design and testing shall comply with the requirements of the SCDOT GDM and the Special Provisions listed in Exhibit 5. Geotechnical information provided as part of this RFP is intended for use in the design of this project. The CONTRACTOR shall confirm that provided geotechnical information meets the requirements for a geotechnical investigation for this specific project as contained in the GDM. If the requirements are not met, then the CONTRACTOR shall provide additional geotechnical investigation to meet the geotechnical requirements for this specific project.

Based on the DEPARTMENT'S preliminary review of the existing geotechnical information, under the most current GDM requirements developed since the report, and contrary to the information provided in the Baseline Geotechnical Report, it appears that ground modification will be required; however it is the responsibility of the CONTRACTOR to perform a detailed liquefaction and stability analysis to verify the need for ground modification and to ensure all performance limit requirements are met as stated in the GDM. All geotechnical design for ground modifications shall comply with the requirements of the GDM. Listed below are ground modifications acceptable for use on this project. Any ground modification used on this project shall comply with the requirements set forth in the Exhibit 5 Special Provision. If column supported

EXHIBIT 4f – GEOTECHNICAL DESIGN CRITERIA

embankments are used as a ground modification, the design method shall be the Collin Method as outlined in the GDM.

- Prefabricated Earthquake Drains with Filter Fabric
- Prefabricated Vertical Drains
- Ground Modification – Vibro-Stone Columns
- Ground Modification – Vibro-densification
- Deep Soil Mixing
- Compaction Grouting
- High-Strength Geotextile for Embankment Reinforcement
- Geotextile for Separation and Stabilization
- Geogrid Soil Reinforcement
- Lightweight Aggregate
- Muck Excavation
- Bridge Lift Materials
- Reinforced Soil Slopes
- Column-Supported Embankments

SEISMIC DESIGN

Final Site-Specific Seismic Response Analysis curves have been supplied in this criterion. The ADRS curves outlined in the Executive Summary of F&ME’s Site-Specific Seismic Response Analysis dated January 23, 2012, and attached later herein, shall be used in the design of the embankments and bridge structure and are hereby incorporated into and made part of the contract documents.

A summary table of the applicable seismic coefficients is outlined below.

	FEE	SEE
PGA	0.144	0.422
S _{DS}	0.393	1.102
S _{D1}	0.246	1.102

EXHIBIT 5

SPECIAL PROVISIONS

**SPECIAL PROVISIONS
FOR
Replacement of SC 41 Bridge over the Wando River
Charleston / Berkeley Counties**

TABLE OF CONTENTS

(1)	DIVISION 100: ERRATA TO 2007 STANDARD SPECIFICATIONS FOR HIGHWAY CONSTRUCTION:	3
(2)	SECTION 101: STANDARD DRAWINGS:	3
(3)	SECTION 105: CONSTRUCTION STAKES, LINES AND GRADES:.....	3
(4)	SECTION 105: CLAIMS PROCEDURE:.....	3
(5)	SECTION 106: QUALIFIED PRODUCT LISTINGS:	4
(6)	SECTION 106: PLANT/FABRICATOR INSPECTION:	4
(7)	SECTION 106: SOUTH CAROLINA MINING ACT:	4
(8)	SECTION 107: PROJECT BULLITEN BOARDS:	5
(9)	SECTION 107: FAIR LABOR STANDARDS ACT OF 1938, AS AMENDED:	5
(10)	SECTION 107: APPLICATION OF DAVIS-BACON AND RELATED ACTS TO INDEPENDENT TRUCK DRIVERS AND MISCELLANEOUS CONSTRUCTION ACTIVITIES:	5
(11)	SECTION 107: DISADVANTAGED BUSINESS ENTERPRISES (DBE) GOALS AND REQUIREMENTS:	5
(12)	SECTION 107: LATE DISCOVERY OF ARCHAEOLOGICAL/HISTORICAL REMAINS ON FEDERAL AID PROJECTS AND APPROVAL OF DESIGNATED BORROW PITS:	5
(13)	SECTION 107: REQUIREMENTS FOR FEDERAL AID CONTRACTS WHICH AFFECT SUBCONTRACTORS, DBE HAULERS, MATERIAL SUPPLIERS AND VENDORS:.....	6
(14)	SECTION 107: SPECIFIC EQUAL EMPLOYMENT OPPORTUNITY RESPONSIBILITY TRAINING SPECIAL PROVISIONS:.....	6
(15)	SECTION 107: DBE PARTICIPATION:	6
(16)	SECTION 107: CONTRACT PROVISION TO REQUIRE CERTIFICATION AND COMPLIANCE CONCERNING ILLEGAL ALIENS	6
(17)	SECTION 107: CRANE SAFETY (REVISED 05/1/2011):.....	6
(18)	SECTION 107: REQUIRED MEDIA NOTIFICATION FOR CONSTRUCTION PROJECTS:.....	7
(19)	SECTION 107: PERMITS:	7
(20)	SECTION 108: PARTNERING:.....	8
(21)	SECTION 108: CRITICAL PATH METHOD CONSTRUCTION SCHEDULES:.....	8
(22)	SECTION 108: FAILURE TO COMPLETE THE WORK ON TIME	8
(23)	SECTION 109: PAYMENT SCHEDULE	9
(24)	SECTION 109: REFERENCES TO UNIT PRICING:	10
(25)	SECTION 109: RETAINAGE	10
(26)	SECTION 109: PROMPT PAYMENT CLAUSE:	10
(27)	SECTION 109: FUEL ADJUSTMENT:	10
(28)	SECTION 202: RECLAIMING EXISTING ROADWAY:.....	10
(29)	SECTION 202: STAGED REMOVAL OF EXISTING BRIDGES:	11
(30)	SECTION 202: REMOVAL OF EXISTING GUARDRAIL:	11
(31)	SECTION 202: REMOVAL OF STRUCTURES AND OBSTRUCTIONS:	11
(32)	SECTION 203: BORROW PITS ON LARGE PROJECTS:	11
(33)	SECTION 204: TEMPORARY SHORING WALL:	11
(34)	SECTION 208: FINE GRADING:	12
(35)	SECTION 305: MAINTENANCE STONE:	12
(36)	SECTION 401: PRICE ADJUSTMENT FOR LIQUID ASPHALT BINDER:.....	12
(37)	SECTION 401: HOT MIX ASPHALT (HMA) QUALITY ASSURANCE:	12
(38)	SECTION 401: HOT-MIX ASPHALT RIDEABILITY:	12
(39)	SECTION 401: TRANSPORTATION AND DELIVERY OF MIXES:.....	12
(40)	DIVISION 600: MANUAL ON UNIFORM TRAFFIC CONTROL DEVICES:.....	12
(41)	DIVISION 600: RULE ON WORK ZONE SAFETY AND MOBILITY:.....	12
(42)	DIVISION 600, ETAL.: ADHESIVELY BONDED ANCHORS AND DOWELS:.....	13

EXHIBIT 5 – SPECIAL PROVISIONS

(43) DIVISION 600: EVALUATION OF RETROREFLECTIVITY:..... 13

(44) SECTION 601: PENALTY FOR VIOLATING LANE CLOSURE RESTRICTIONS:..... 14

(45) SECTION 609: HIGH PRESSURE WATER METHOD FOR REMOVAL OF PAVEMENT
MARKINGS:..... 14

(46) DIVISION 700: DYNAMIC LOAD TESTING WITH PILE DRIVING ANALYZER AND
STATIC LOAD TESTING:..... 14

(47) SECTION 701: CONCRETE BATCHING AND MIXING:..... 14

(48) SECTION 701: NON-CONFORMING CONCRETE:..... 14

(49) SECTION 709: ELASTOMERIC CONCRETE FOR EXPANSION JOINT HEADERS:..... 14

(50) SECTION 711: PILE AND DRIVING EQUIPMENT DATA FORM: 14

(51) SECTION 712: DRILLED SHAFTS:..... 14

(52) SECTION 714: PIPE END TREATMENTS (2/5/2010)..... 14

(53) SECTION 714: SMOOTH WALL PIPE: 17

(54) SECTION 720: DETECTABLE WARNING SURFACE: 19

(55) SECTION 726: POLYMER MODIFIED ASPHALT EXPANSION JOINT SYSTEM..... 20

(56) SECTION 727: CROSSHOLE SONIC LOGGING OF DRILLED SHAFT FOUNDATIONS: 22

(57) SECTION 805: GUARDRAIL END TERMINAL - TYPE T: 22

(58) SECTION 805: HEIGHT OF W-BEAM GUARDRAIL: 22

(59) SECTION 805: GEOCOMPOSITE WALL DRAIN DATED MAY 6, 2003: 22

(60) SECTION 805: GEOTEXTILE FOR DRAINAGE FILTRATION: 25

(61) SECTION 805: COLD APPLIED WATERPROOFING DATED MAY 29, 2003:..... 25

(62) SECTION 809: RIGHT OF WAY PLAT: 27

(63) SECTION 810: SEEDING: 28

(64) SECTION 815: EROSION CONTROL MEASURES: 28

(65) SAFETY FENCE:..... 32

(66) DIVISION 200: SETTLEMENT PLATES: 32

(67) NONWOVEN GEOTEXTILE INTERLAYER FABRIC FOR CONCRETE PAVEMENT: 37

(68) DIVISION 200: GROUND MODIFICATION – COMPACTION GROUTING COLUMNS..... 39

(69) DIVISION 200: GEOTEXTILES FOR SEPARATION AND STABILIZATION 47

(70) DIVISION 200: BRIDGE LIFT MATERIALS..... 51

(71) DIVISION 200: DEEP SOIL MIXING..... 52

(72) DIVISION 200: GEOGRID SOIL REINFORCEMENT..... 74

(73) DIVISION 200: GROUND MODIFICATION – VIRBRO STONE COLUMN 78

(74) DIVISION 200: LIGHTWEIGHT AGGREGATES 81

(75) DIVISION 200: HIGH-STRENGTH GEOTEXTILE FOR EMBANKMENT REINFORCEMENT 83

(76) SECTION 203: MUCK EXCAVATION 90

(77) DIVISION 200: PREFABRICATED EARTHQUAKE DRAIN WITH FILTER FABRIC 91

(78) DIVISION 200: PREFABRICATED VERTICAL DRAIN WITH FABRIC 98

(79) DIVISION 200: REINFORCED SOIL SLOPES (RSS)..... 105

(80) DIVISION 200: MONITORING DEVICES - PIEZOMETER 109

(81) DIVISION 200: SETTLEMENT SENSORS 109

(82) DIVISION 200: TOTAL PRESSURE CELLS..... 114

(83) DIVISION 200: VIBRATING WIRE DATA COLLECTION CENTERS 117

(84) DIVISION 200: VIBRATING WIRE ROD EXTENSOMETER..... 119

(85) DIVISION 700: AXIAL O-CELL LOAD TESTING OF DRILLED SHAFTS 121

(86) DIVISION 700: APPLE LOAD TESTING..... 125

(87) DIVISION 700: STATNOMIC LOAD TESTING..... 129

(88) PAVING UNDER GUARDRAIL..... 133

(89) DIVISION 600: ADHESIVELY BONDED ANCHORS AND DOWELS 138

(90) ELASTOMERIC CONCRETE FOR EXPANSION JOINT HEADERS 141

(91) DIVISION 702: CONCRETE STRUCTURES – PREFORMED JOINT FILLER..... 144

(92) TEMPORARY SHORING WALL 144

(93) DIVISION 200: VIBRO COMPACTION..... 145

(94) SECTION 203: BORROW EXCAVATION..... 149

(95) DIVISION 700: MONITORING OF CONSTRUCTION-RELATED EARTHBORNE
VIBRATIONS 150

(96) SECTION 729: NAVIGATION LIGHTS FOR BRIDGE..... 152

EXHIBIT 5 – SPECIAL PROVISIONS

(1) DIVISION 100: ERRATA TO 2007 STANDARD SPECIFICATIONS FOR HIGHWAY CONSTRUCTION:

The Supplemental Specification entitled "Errata to 2007 Standard Specifications for Highway Construction" dated **May 4, 2009** in **Exhibit 6** is hereby amended to include the following:

Division 100 is amended as follows:

Page 4, The table in **Subsection 101.2** is amended as follows:

SCDOT OFFICIALS AND OFFICES			
DELETIONS		REPLACEMENTS	
SHE*	State Highway Engineer	DSE*	Deputy Secretary for Engineering

*Wherever it appears in the text, replace the deleted abbreviation with the new abbreviation.

(2) SECTION 101: STANDARD DRAWINGS:

The Bidders are hereby advised that this project shall be constructed using the 2011 Standard Drawings with all updates effective at the time of the letting. The Standard Drawings are available for download at http://www.scdot.org/doing/sd_disclaimer.shtml. All drawings that are updated are labeled with their effective letting date in red.

The Standard Drawings are available to purchase through the SCDOT Engineering Publications Sales Center. The Engineering Publication Sales Center is located in Room G-19 (basement level) of the SCDOT Headquarters Building, 955 Park Street, Columbia, South Carolina.

All references in the plans, standard specifications, supplemental specifications, supplemental technical specifications or special provisions to drawings under the previous numbering system are hereby updated to the new drawing numbers. Refer to sheets 000-205-01 through 000-205-07 to find new drawing numbers when looking for references to older drawing numbers.

(3) SECTION 105: CONSTRUCTION STAKES, LINES AND GRADES:

Section 105.8.2 applies to this project. Payment for this work shall be made according to the following schedule:

Percent Contract Complete	Percent of Stakes, Lines, and Grades bid amount to be paid
1 – 5	20
6 – 15	40
16 – 29	60
30 – 49	70
50 – 69	80
70 – 89	90
90 - 100	100

(4) SECTION 105: CLAIMS PROCEDURE:

See Supplemental Specification entitled "Claims Procedure" dated **February 12, 1997**, in **Exhibit 6**. For this project, the STANDING DISPUTE REVIEW BOARD is designated.

EXHIBIT 5 – SPECIAL PROVISIONS

6. METHOD OF MEASUREMENT:

- 6.1 Measurement will be made for Cross Slope Verification after the RCE has reviewed and approved the work, including all submittals. Measurement is one lump sum.
- 6.2 No measurement will be made for any items of work required to make corrections to the final pavement cross slopes as deemed necessary by the Department.

7. BASIS OF PAYMENT:

- 7.1 Cross Slope Verification will include any costs for interpreting the data, electronic and hard copies of survey data for the Engineer, traffic control, and any and all, tools, labor, and equipment necessary to perform the cross slope verification. The RCE will approve payment based on the following schedule:

Approval of the Initial Corrective Measures Plan	40%
Submittal of Progress Measurement for First Uniform Lift	60%
Submittal of the Final Pavement Cross Slope Measurements	80%
Acceptance of the As-Built Plan Sheets and Electronic Data	100%

- 7.2 The bid item number and description is:

ITEM NUMBER	DESCRIPTION	UNIT
1055102	CROSS SLOPE VERIFICATION	LS

(5) SECTION 106: QUALIFIED PRODUCT LISTINGS:

All references to "Approval Sheet" or "Approval Policy" are to be replaced with "Qualified Products Listings (QPL)" and "Qualified Products Policies (QPP)" respectively. This change includes all references in the SCDOT Standard Drawings, SCDOT Standard Specifications, SCDOT Supplemental Specifications, SCDOT Special Provisions, SCDOT Supplemental Technical Specifications, SCDOT Internet and Intranet websites, and all other documents produced by SCDOT.

(6) SECTION 106: PLANT/FABRICATOR INSPECTION:

Subsection 106.4, **Plant Inspection**, of the Standard Specifications shall be amended with the following:

Change the subsection title to **Plant/Fabricator Inspection** and add the following sentence after the first sentence:

"Provide 14 calendar days written notice to the Materials and Research Engineer prior to beginning fabrication work for Department projects."

(7) SECTION 106: SOUTH CAROLINA MINING ACT:

See Attached Supplemental Specification Dated **March 20, 2003** on page Error! Bookmark not defined..

This Supplemental Specification is hereby modified as follows:

Paragraph 9 is hereby deleted and replaced with the following:

EXHIBIT 5 – SPECIAL PROVISIONS

The deputy secretary for engineering, or his duly appointed representative, will make a final inspection of the reclaimed area and keep a permanent record of his approval thereof. A map or sketch providing the location and approximate acreage of each pit used on the project will be provided to the resident construction engineer for inclusion in the final plans.

The last paragraph is hereby deleted and replaced with the following:

The contractor shall comply with the provisions of the plan that are applicable to the project as determined by the engineer. Seeding or other work necessary to comply with the plan on pits furnished by the contractor shall be at the expense of the contractor. Seeding shall be in accordance with SC-M-810 (latest version) which can be found at http://www.scdot.org/doing/road_SupTechSpec.aspx.

(8) SECTION 107: PROJECT BULLETIN BOARDS:

In accordance with the Required Contract Provisions Federal-Aid Construction Contracts Section II, Item 3, Part d, add the following:

For this project, a bulletin board shall be placed at the project location. Mount the project bulletin board in a permanent location within the project limits so that it is visible and accessible at all times. Notify the RCE and all subcontractors as to the location of the bulletin board.

(9) SECTION 107: FAIR LABOR STANDARDS ACT OF 1938, AS AMENDED:

Attention is directed to this Federal Legislation, which has been enacted into law. The contractor will be responsible for carrying out all of the provisions of this legislation, which may affect this contract.

(10) SECTION 107: APPLICATION OF DAVIS-BACON AND RELATED ACTS TO INDEPENDENT TRUCK DRIVERS AND MISCELLANEOUS CONSTRUCTION ACTIVITIES:

See attached Supplemental Specification dated **June 13, 1990** in **Exhibit 7**.

(11) SECTION 107: DISADVANTAGED BUSINESS ENTERPRISES (DBE) GOALS AND REQUIREMENTS:

See attached Supplemental Specification entitled special provision "Disadvantaged Business Enterprises (DBE) Federal Projects" dated **March 3, 2010** in Exhibit 7 for specific requirements that must be met. Also see attached "Instructions To Bidders Federal Projects" dated **April 2, 2011** in **Exhibit 7**.

The contractor's attention is directed to the electronic DBE BIN file found on the electronic bidding service website, *Bid Express*, containing data from the "Directory of Certified Disadvantaged Business Enterprises" approved for use in each particular letting. It specifies the amount (percentage) that the contractor may count toward its appropriate DBE Goals of expenditure for materials and supplies obtained from DBE Suppliers and Manufacturers.

For this project, the Contractor shall use the "Directory of Certified Disadvantaged Business Enterprises" to determine appropriate DBE involvement.

(12) SECTION 107: LATE DISCOVERY OF ARCHAEOLOGICAL/HISTORICAL REMAINS ON FEDERAL AID PROJECTS AND APPROVAL OF DESIGNATED BORROW PITS:

See attached Supplemental Specification dated **August 7, 1991** in **Exhibit 7**.

EXHIBIT 5 – SPECIAL PROVISIONS

(13) SECTION 107: REQUIREMENTS FOR FEDERAL AID CONTRACTS WHICH AFFECT SUBCONTRACTORS, DBE HAULERS, MATERIAL SUPPLIERS AND VENDORS:

See attached Supplemental Specification dated **March 1, 2010** in **Exhibit 7**.

(14) SECTION 107: SPECIFIC EQUAL EMPLOYMENT OPPORTUNITY RESPONSIBILITY TRAINING SPECIAL PROVISIONS:

See attached Supplemental Specification entitled "Specific Equal Employment Opportunity Responsibilities Training Special Provisions" dated **August 20, 1975**, revised **April 1, 2004**. In **Exhibit 7**.

The Supplemental Specification states "...the contractor will be reimbursed 80 cents per hour of training given an employee on this contract in accordance with an approved training program." The Contractor is advised that the Department will not accept bids with any unit price other than \$0.80/Hr for the item: ON-THE JOB TRAINEE. Bids that are submitted with any other unit price will be corrected by the Department to \$0.80/Hr, and the Grand Total bid amount adjusted accordingly.

(15)SECTION 107: DBE PARTICIPATION:

The Bidder is encouraged to use DBE subcontractors on this project. All DBE participation shall be reported to the RCE on the DBE Quarterly Report.

(16) SECTION 107: CONTRACT PROVISION TO REQUIRE CERTIFICATION AND COMPLIANCE CONCERNING ILLEGAL ALIENS

By submission of this bid, the bidder as the prime contractor does hereby agree:

- a. to certify its compliance with the requirements of Chapter 14 of Title 8 of the S.C. Code of Laws regarding Unauthorized Aliens and Public Employment;
- b. to provide SCDOT with any documents required to establish such compliance upon request; and
- c. to register and participate and require agreement from subcontractors and sub-subcontractors to register and participate in the federal work authorization program to verify the employment authorization of all new employees, or to employ only workers who supply the documents required pursuant to S.C.Code 8-14-20(B)(2).

(17) SECTION 107: CRANE SAFETY (REVISED 05/1/2011):

CRANE SAFETY:

The contractor's attention is directed to the following Crane Safety criteria. All applicable items under the submittal list section shall be submitted to the Resident Construction Engineer (RCE) before any crane operations may begin. If any personnel or equipment is changed or added, all applicable items shall be updated and submitted to the RCE before continuing with crane(s) operations.

All contractors shall comply with the manufacturer specifications and limitations applicable to the operation of any and all cranes and derricks. Prime contractors and sub-contractors shall comply with the latest Occupational Safety and Health Administration (OSHA) regulations, adopted American National Standards Institute (ANSI) and American Society of Mechanical Engineers (ASME) crane standards, and other applicable standards including, but not limited to the following:

- OSHA 29 CFR 1926 Subpart CC "Cranes and Derricks in Construction"
- OSHA 29 CFR 1926.251 "Rigging Equipment for Material Handling"
- ASME B30.5-2007 "Mobile and Locomotive Cranes"
- ASME B30.8-2010 "Floating Cranes and Floating Derricks"

EXHIBIT 5 – SPECIAL PROVISIONS

- ASME B30.22-2005 “Articulating Boom Cranes”
- ASME B30.26-2010 “Rigging Hardware”

Submittal List

1. **Crane Operators:** All crane operators shall be certified by the National Commission for the Certification of Crane Operators (NCCCO), National Center for Construction Education and Research (NCCER), or Crane Institute of America Certification (CIC).
 - a. Contractor shall submit a copy of the NCCCO, NCCER, or CIC certification for each crane operator prior to performing any crane operations on the job site. The original certification card shall be available for review upon request and must remain current within a 5 year expiration date for the duration of the job. (Contractors with a crane operator-in- training on the jobsite shall comply with all the OSHA Subpart CC requirements).
 - b. Contractor shall submit a copy of the current Crane Operators Medical Evaluation card (3 year expiration) in the form of NCCCO, NCCER or CIC Physical Examination form or equivalent meeting the ASME B30.5 requirement or a current USDOT Medical Examiner’s Certificate card (2 year expiration). The original medical card or equivalent for all crane operators shall be available for review upon request.
2. **Competent Person:** The named competent person will have the responsibility and authority to stop any work activity due to safety concerns.
 - a. Contractor shall submit the name and qualifications of the “Competent Person” as defined by OSHA Subpart CC responsible for all crane safety and lifting operations.

(18) SECTION 107: REQUIRED MEDIA NOTIFICATION FOR CONSTRUCTION PROJECTS:

Contractors are encouraged to co-operate with the news media since all projects are constructed with public funds. Because the scope of this project will cause disruption of normal traffic flow, the Contractor is required to notify the public, in a timely manner, of disruptive activities such as lane closures.

The Contractor is required to utilize area media to accomplish public notification of traffic disruptions.

The Contractor is required to deal directly with the news media and all reasonable efforts should be made to co-operate with the media. However, the safety, security and construction schedule on site should not be disrupted in order to accomplish this. The Contractor may co-ordinate these activities with and receive guidance from the SCDOT Public Affairs Office.

(19) SECTION 107: PERMITS:

All permits necessary for completion of this project shall be procured by the Contractor. Failure to adequately comply with the provisions of permits or any other requirements from the permitting agencies will result in the stoppage of contract operations until corrective actions have been taken.

EXHIBIT 5 – SPECIAL PROVISIONS

Fines assessed by permitting agencies to the Department as the result of the Contractor's non-compliance or violation of said permit provisions will be paid by the Department and subsequently deducted from the Contractor's monthly pay estimate.

(20) SECTION 108: PARTNERING:

(A) Covenant of Good Faith and Fair Dealing

This Contract imposes an obligation of good faith and fair dealing in its performance and enforcement.

The Contractor and Department, with a positive commitment to honesty and integrity, agree to the following mutual duties:

- (1) Each will function within the laws and statutes applicable to their duties and responsibilities.
- (2) Each will avoid hindering the other's performance.
- (3) Each will proceed to fulfill its obligations diligently.
- (4) Each will cooperate in the common endeavor of the Contract.

(B) Partnering

The Department encourages the foundation of cohesive partnering with the Contractor and its principle subcontractors and suppliers. This partnering is not a legal partnership as defined by South Carolina law. Partnering will be structured to draw on the strengths of each organization to identify and achieve reciprocal goals. The objectives are effective and efficient contract performance and completion within budget, on schedule, and in accordance with the Contract.

The establishment of a partnering charter will not change the legal relationship of the parties to the contract nor relieve either party from any of the terms of the Contract.

Any cost associated with effectuating partnering will be agreed to by the Department and the Contractor and will be shared equally between them.

(21) SECTION 108: CRITICAL PATH METHOD CONSTRUCTION SCHEDULES:

See attached Supplemental Specification dated **March 1, 2007** in **Exhibit 6**. The attached specification is hereby modified by changing the first sentence in the section entitled "Submission, Review, and Acceptance Process – Monthly Updates" to the following:

"Monthly updates shall be made no later than 15 days following the most recent estimate period end date and shall have a data date the same as the most recent estimate period end date."

(22) SECTION 108: FAILURE TO COMPLETE THE WORK ON TIME

Paragraph 1 of **Section 108.9** is hereby replaced with the following:

If the Contractor fails to substantially complete the work by the contract completion date, the Contractor is liable for liquidated damages. Liquidated damages will be assessed for each day beyond the contract completion date that work items are not completed. This includes the application of thermoplastic, raised pavement markers and grassing. Days to be charged for liquidated damages will not stop due to seasonal restrictions. The daily liquidated damages rate is determined from the following schedule. The date of substantial completion is determined by the RCE.

(23) SECTION 109: PAYMENT SCHEDULE

Subsection 109.7 of the SCDOT 2007 Standard Specifications for Highway Construction is replaced as follows:

Pursuant to the **Critical Path Method Construction Schedules** Supplemental Specification dated March 1, 2007, submit the Critical Path Method (CPM) schedule within 30 days of award. Once accepted by SCDOT, the project’s initial baseline cost loaded CPM will be used for SCDOT budget purposes and the contractor will not be paid in excess of the cumulative amount shown on the schedule through each payment date; regardless of what subsequent monthly updates indicate. For example, see chart below:

Pay period ending	12/16/11	1/16/12	2/16/12	3/16/12	4/16/12	5/16/12
Baseline CPM Planned Payout in Millions (Cumulative to Date)	2.0 (2.0)	3.0 (5.0)	3.0 (8.0)	4.0 (12.0)	4.0 (16.0)	3.0 (19.0)
Actual work performed (Cumulative to Date)	1.5 (1.5)	2.0 (3.5)	3.5 (7.0)	6.0 (13.0)	3.0 (16.0)	4.0 (20.0)
Payout by SCDOT (Cumulative to Date)	1.5 (1.5)	2.0 (3.5)	3.5 (7.0)	5.0 (12.0)	4.0 (16.0)	3.0 (19.0)

Partial payment estimates will be generated in SiteManager (computerized construction management system) based on actual quantities installed. If actual quantities installed exceed the cumulative schedule amount to date, a negative adjustment will be made in SiteManager to adjust the pay as necessary. For previous work exceeding the schedule amount, payments will be released as work progresses and payouts fall below the scheduled cumulative amount, never to exceed the cumulative scheduled amount through that pay period.

If significant contract changes are necessary, and upon approval by the SCDOT, a re-baseline to the initial CPM will be allowed per the CPM schedule specification and the payout schedule may be adjusted accordingly.

All subcontractors must be paid in accordance with the Prompt Payment Clause (Supplemental Specification dated January 5, 2012) for the quantities used to generate the partial payment estimates. In instances where a payout by SCDOT is less than the actual work installed under a given estimate, the Prompt Payment Clause is hereby amended to require full payment to all subcontractors, for work complete, within 7 days of receipt of said SCDOT payout

Partial Payments will be made no more than once each month as the work progresses. The monthly partial payment periods end at the end of the day on the following dates for the respective Engineering Districts:

- Engineering District Nos. 2, 3, and 5 – Last day of each month.
- Engineering District Nos. 1, 4, 6, and 7 – 16th day of each month.

EXHIBIT 5 – SPECIAL PROVISIONS

(24) SECTION 109: REFERENCES TO UNIT PRICING:

Any references in the contract documents to unit price, measurement, and payment, are typical references for design-bid-build contracts and are not applicable to the extent they effect payment on Design-Build contracts. The Design-Build contractor's schedule of values shall provide sufficient detail to compare work progress to the contractor's schedule and determine appropriate periodic payments.

(25) SECTION 109: RETAINAGE

If the Contractor's progress is judged to be delinquent or portions of the work are defective, the Department reserves the right to withhold retainage. The total amount retained will be sufficient to cover anticipated liquidated damages and the cost to correct defective work.

(26) SECTION 109: PROMPT PAYMENT CLAUSE:

See attached Supplemental Specification dated **January 5, 2012** in **Exhibit 6**.

(27) SECTION 109: FUEL ADJUSTMENT:

No fuel adjustment will be made on this Project.

(28) SECTION 202: RECLAIMING EXISTING ROADWAY:

Description:

This work consists of the restoration of paved areas. These areas are typically shown as hatched areas on the plans when outside the construction limits.

Materials:

None

Construction Requirements:

- 1.) Asphalt Pavement with Earth Base: Remove and dispose of areas of pavement shown as hatched areas on the plans. Grade the area to properly drain. Seed the area in accordance with Section 810.
- 2.) Asphalt Pavement with Stone Base: Remove and dispose of areas of pavement and base shown as hatched areas on the plans. Grade the area to properly drain. Seed the area in accordance with Section 810.
- 3.) Earth roadway or Bituminous Surfacing with Earth Base: Scarify existing areas of roadway. Grade the area to properly drain. Seed the area in accordance with Section 810.
- 4.) Bituminous Surfacing with Stone Base: Remove and dispose of areas of pavement and base shown as hatched areas on the plans. Grade the area to properly drain. Seed the area in accordance with Section 810.

Suitable materials may be used for embankment construction on the project. In the event that removed materials are used for embankment construction a corresponding deduction in Unclassified Excavation will be made by the Resident Construction Engineer.

Measurement:

Removed asphalt pavement greater than 2 inches in depth will be measured by the square yard. Removed bituminous surfacing with stone base will be measured by the cubic yard. Removed stone base will be measured by the cubic yard. Scarified areas will not be measured for payment.

Payment:

EXHIBIT 5 – SPECIAL PROVISIONS

Removed asphalt pavement which is greater than 2 inches in depth will be paid at the unit price bid for Removal and Disposal of Existing Asphalt Pavement. Removed bituminous surfacing with stone base will be paid for at the unit price bid for Unclassified Excavation. Removed stone base will be paid for at the unit bid price for Unclassified Excavation. No payment will be made for scarifying earth roadway or bituminous surfacing with earth base. No separate or additional payment will be made for grading necessary to obtain proper drainage.

(29) SECTION 202: STAGED REMOVAL OF EXISTING BRIDGES:

For existing bridges that will be removed in stages, maintain stability of the existing structure at all times while traffic is on the bridge. At a minimum, replace tie rods after removal of any slab sections and maintain bracing on the existing piles at all times while traffic is on the bridge.

(30) SECTION 202: REMOVAL OF EXISTING GUARDRAIL:

Section 202.4.4.3 applies on this project.

(31) SECTION 202: REMOVAL OF STRUCTURES AND OBSTRUCTIONS:

Section 202 is amended as follows:

Page 92 **Subsection 202.5**, item 5, second bullet:

Change the words "brick sidewalk" to "concrete, brick or stone sidewalks".

(32) SECTION 203: BORROW PITS ON LARGE PROJECTS:

Borrow materials for this project shall not be obtained from wetlands, streams, or rivers.

(33) SECTION 204: TEMPORARY SHORING WALL:

Subsection 204.4.5.2 is amended to include the addition of the following section:

"The retaining wall system shall be designed to limit deformations (vertical and lateral displacements) that would affect the stability or performance of any adjacent structures (MSE walls, Bridge foundations, Pavement Structure, Approach Slabs, Embankment (stage construction), etc.). Deformations that must be limited shall include, but not be limited to, vertical settlement, sliding, bulging, bowing, bending, and buckling. Design criteria for allowable deformations shall be dependent on the type of structure that will be influenced by any deformation of the temporary shoring wall. Regardless of the type of structure being retained, the deformation criteria shall not exceed 3 inches without acceptance from the Geotechnical Design Support Engineer. An instrumentation plan for monitoring deformations of the temporary shoring and any adjacent structure shall be submitted along with the shop drawings. The instrumentation plan shall indicate the maximum allowable deformations of the temporary shoring and adjacent structures. Typical instrumentation used for monitoring deformations are survey targets, settlement monuments, crack gages, inclinometers, and tilt monitors. The monitoring locations shall be established in a manner that they can be monitored consistently and obtain repeatable measurements for the entire construction period. A monitoring schedule that the Contractor will use during construction will also be included with the instrumentation plan. The Contractor shall submit periodic monitoring reports to the RCE in accordance with the approved instrumentation plan. Any changes in frequency of monitoring or report submittal must be sent to the Geotechnical Design Support Engineer for acceptance. If the initial instrumentation plan is found not to be documenting adequately the movements of the temporary shoring or adjacent structures, the Contractor will revise the instrumentation plan and resubmit the revised plan for review and acceptance.

EXHIBIT 5 – SPECIAL PROVISIONS

If the measured deformations exceed the maximum allowable deformations shown in the instrumentation plan, the Contractor will be required to stop work immediately, and at his own expense, correct the situation to the satisfaction of the Department prior to resumption of construction activities. Extended monitoring after construction may be required if adjacent structures have been affected by the construction. The extended monitoring of the adjacent structures shall continue until the structures have stabilized and the Department concurs with the results and conclusions of the monitoring report. All costs associated with developing the instrumentation plan, purchasing instrumentation, installing instrumentation, and monitoring of the instrumentation shall be included in the unit cost of the temporary shoring item.”

(34) SECTION 208: FINE GRADING:

Section 208 is amended as follows:

Page 131, **Subsection 208.5**, Paragraph 1, first sentence:
Insert the word “paved” before the word “shoulders”.

(35) SECTION 305: MAINTENANCE STONE:

Maintenance Stone used on this project shall conform to the gradation requirements of Section 305, or to the gradation specified for Aggregate No. CR-14 in the Standard Specifications.

(36) SECTION 401: PRICE ADJUSTMENT FOR LIQUID ASPHALT BINDER:

No price adjustment for liquid asphalt binder will be made on this Project.

(37) SECTION 401: HOT MIX ASPHALT (HMA) QUALITY ASSURANCE:

Reference is made to the Supplemental Technical Specification “Hot Mix Asphalt (HMA) Quality Assurance.” For the purposes of applying this Supplemental Technical Specification, there will be no pay factor adjustment greater than 100% for any given lot. When applying pay factor adjustments of less than 100%, a unit price of \$75 per ton will be used.

(38) SECTION 401: HOT-MIX ASPHALT RIDEABILITY:

Reference is made to the Supplemental Technical Specification “Hot-Mix Asphalt Rideability.” For the purposes of applying this Supplemental Technical Specification, there will be no pay factor adjustment greater than 100%. When applying pay factor adjustments of less than 100%, price Adjustments will be calculated based on \$75 per ton.

(39) SECTION 401: TRANSPORTATION AND DELIVERY OF MIXES:

See attached Supplemental Specification dated **July 1, 2010** in **Exhibit 6**.

(40) DIVISION 600: MANUAL ON UNIFORM TRAFFIC CONTROL DEVICES:

“The Contractor is hereby advised that the Department has adopted the MUTCD 2009 – Manual on Uniform Traffic Control Devices for use on all projects. All references to the South Carolina Manual on Uniform Traffic Control Devices (SCMUTCD) are hereby revised to read “MUTCD – 2009 Edition”.

(41) DIVISION 600: RULE ON WORK ZONE SAFETY AND MOBILITY:

EXHIBIT 5 – SPECIAL PROVISIONS

The Contractor is responsible for complying with the Rule on Work Zone Safety and Mobility. This Project is classified as “**intermediate**”. The Contractor shall submit a Traffic Management Plan in compliance with the Rule on Work Zone Safety and Mobility. See “Rule on Work Zone Safety and Mobility” in the Project Information section.

(42) DIVISION 600, Etal.: ADHESIVELY BONDED ANCHORS AND DOWELS:

See attached Supplemental Specification dated **September 1, 2008** in **Exhibit 6**.

This Supplemental Specification applies when Adhesively Bonded Anchors or Dowels are called for in the Plans or Detailed Drawings.

The following Standard Drawings have been identified as showing Adhesively Bonded Anchors or Dowels:

605-205-03	Temporary Concrete Barrier
605-210-04	Temporary Concrete Barrier
605-310-01	Temporary Concrete Barrier
605-315-00	Temporary Concrete Barrier
605-320-00	Temporary Concrete Barrier
605-325-00	Temporary Concrete Barrier
605-330-00	Temporary Concrete Barrier
651-105-00	Barrier Mounted Sign Post
657-100-00	Overhead Sign Support Roadway Bridges
722-105-01	Box Culvert (Used to connect headwall, wingwalls, and for extensions)
805-120-00	Guardrail (W Beam) Base Plate Connection
805-405-03	Guardrail (Tubular Beam) Bridge Railing
805-405-04	Guardrail (Tubular Beam) Bridge Railing
806-505-00	Fence (Ornamental Steel Picket)

It is the contractor’s responsibility to determine if Adhesively Bonded Anchors or Dowels are a part of the project, and to comply with the provisions of the Supplemental Specification.

(43) DIVISION 600: EVALUATION OF RETROREFLECTIVITY:

Within 20 days of initial application, the Contractor shall arrange for an independent party to evaluate the retroreflectivity of the pavement markings using a mobile retroreflectometer utilizing 30 meter CEN geometry. All lines shall be measured in both directions. The independent party conducting the measurements shall furnish directly to the Department a report detailing the average of the readings over one mile segments for each type of long line (white edgeline, white lane lines, yellow edgelines) along the length of the project. Average measurements shall also be provided along each ramp. Interstate mile markers may be used for beginning and ending points, with the first and last segments in each direction being less than one mile in length. The initial minimum retroreflectivity values shall be as follows:

Retroreflectivity (mcd/lux/m²)

<u>White</u>	<u>Yellow</u>
450	350

A second evaluation shall take place within 20 days prior to the end of the 180 day observation period. The evaluation method shall be the same as described above. The 180 day minimum retroreflectivity values shall be as follows:

Retroreflectivity (mcd/lux/m²)

EXHIBIT 5 – SPECIAL PROVISIONS

White Yellow
400 300

All markings failing to meet the initial minimum retroreflectivity requirements by more than 50 mcd/lux/m² shall be replaced immediately at the Contractor's expense. All markings failing to meet initial requirements by less than 50 mcd/lux/m² may be reevaluated at the time of the 180 day evaluation unless the defect causing the lower readings is obvious to the Engineer.

- (44) SECTION 601: PENALTY FOR VIOLATING LANE CLOSURE RESTRICTIONS:**
The Contractor is advised that the Lane Closure Restrictions for SC 41 outlined in the Work Zone Traffic Control Requirements will be strictly enforced. Should lane closures remain in place or not be completely removed by the time specified in the Traffic Control Special Provisions, a penalty will be assessed at the rate of **\$500 (Five hundred Dollars)** for each 1/4 hour interval (or any portion thereof). Should lane closures remain in place or not be completely removed for a period of longer than one hour beyond the time specified by the Traffic Control Special Provisions the penalty will increase to **\$1,000.00 (One Thousand Dollars)** for each 1/4 hour interval (or any portion thereof).

See attached Supplemental Specification dated **January 3, 2013** in **Exhibit 6**.

- (45) SECTION 609: HIGH PRESSURE WATER METHOD FOR REMOVAL OF PAVEMENT MARKINGS:**

See attached Supplemental Specification dated **July 2, 2009**, in **Exhibit 6**.

- (46) DIVISION 700: DYNAMIC LOAD TESTING WITH PILE DRIVING ANALYZER AND STATIC LOAD TESTING:**

The Contractor will be responsible for dynamic and static load testing of all foundations if required by design. See **Exhibit 4b**, "Project Criteria – Structures," for additional information.

- (47) SECTION 701: CONCRETE BATCHING AND MIXING:**

See attached Supplemental Specification dated **April 5, 2010** in **Exhibit 6**.

- (48) SECTION 701: NON-CONFORMING CONCRETE:**

For purposes of applying the reduced payment and below strength provisions of Subsection 701.2.12.4 of the Standard Specifications, a unit price of \$750 per cubic yard will be used.

- (49) SECTION 709: ELASTOMERIC CONCRETE FOR EXPANSION JOINT HEADERS:**

See attached Supplemental Specification dated **June 1, 2010** in **Exhibit 6**.

- (50) SECTION 711: PILE AND DRIVING EQUIPMENT DATA FORM:**

Pile and Driving Equipment Data Form is included in **Exhibit 6**.

- (51) SECTION 712: DRILLED SHAFTS:**

Drilled Shaft Forms are included in **Exhibit 6**.

- (52) SECTION 714: PIPE END TREATMENTS (2/5/2010)**

EXHIBIT 5 – SPECIAL PROVISIONS

REFERENCE: SCDOT Supplemental Technical Specification SC-M-714

DESCRIPTION:

For exposed pipe culvert ends, provide an end treatment in accordance with this special provision.

MATERIALS:

Rigid pipe culvert is Reinforced Concrete Pipe (RCP: 714-205-00). Flexible pipe culvert is either Spiral Ribbed Aluminum Pipe (SRAP: 714-610-00), High Density Polyethylene pipe (HDPE: 714-705-00), or Corrugated Aluminum Alloy Pipe (CAAP: 714-605-00).

Use minimum Class B riprap for pipe up to 84" diameter. Use minimum Class C riprap for pipe 84" diameter or larger.

Use minimum Class 4000 concrete (4000P for precast).

Use ASTM A-706 grade 60, low-alloy steel deformed rebar.

Use minimum AASHTO M-196 Alclad 3004-H32 alloy aluminum.

Use Type M Mortar Grout unless specified otherwise.

CONSTRUCTION REQUIREMENTS:

Use one of the following end treatments as specified in the plans or special provisions:



For all exposed crossline pipe ends, when an end treatment is not specified in the plans, use **Pipe Riprap Protection** (804-3xx-xx). For flexible pipe larger than 24" diameter, install pipe straight headwall, pipe end structure, flared end section, or wingwall section in addition to riprap. For all exposed driveway pipe ends where no end treatment is specified in the plans, use **Pipe Riprap Protection** (804-3xx-xx) unless directed otherwise by the engineer.



Use **Beveling of Pipe End** (719-610-00) when specified in the plans or special provisions. Beveled ends may only be used on flexible pipe up to 24" diameter and on rigid pipe up to 60" diameter. When beveling of pipe ends is specified on flexible pipe larger than 24" diameter, install pipe straight headwall, pipe end structure, flared end section, or wingwall section. Use factory fabricated beveled ends for all pipe types unless approved by the Engineer.

EXHIBIT 5 – SPECIAL PROVISIONS



Use **Pipe Straight Headwall** (719-605-00) when specified in the plans or special provisions. Use straight headwall only in locations where pipe exposed end does not face the direction of traffic.



Use **Pipe End Structure** (719-615-00) when specified in the plans or special provisions. Use pipe end structure in locations where pipe exposed end faces the direction of traffic. Pipe end structures may be used in other locations if approved by the RCE.



Use **Pipe Flared End Section** when specified in the plans or special provisions.



Use **Wingwall Section** when specified in the plans or special provisions.



Use **Pipe**

EXHIBIT 5 – SPECIAL PROVISIONS

Completely seal interface between pipe and end treatment with grout. If bricks or shims are used to place pipe, take care to remove all air pockets and voids when grouting.

For systems not designed in the SCDOT Standard Drawings, provide shop drawings, installation procedure and design calculations for review by RCE. Design must include provision to control erosion around the structure and prevent the separation of the end treatment from the pipe system. Design must provide for a proper seal at all construction joints including the interface between the pipe and the structure. Design must be self supporting and not induce any additional loads on the pipe. Submit designs for consideration as new standard drawings to the Design Standards Engineer at the address listed in the SCDOT Standard Drawings book.

MEASUREMENT:

Measure pipe in accordance with SC-M-714

Measure end treatments in accordance with Standard Specifications, Standard Drawings, or Special Provisions.

PAYMENT:

Beveling of pipe ends will be in addition to the standard pipe pay item. Payment for the item Beveling of Pipe Ends includes all labor required to factory (or field, if approved) fabricate a bevel on one end of pipe.

Pipe culvert and end treatments, measured as provided in **SC-M-714 Subsection x.4**, are paid for at the contract unit price for the respective items, which price and payment is compensation for furnishing all material, labor, equipment, tools including hauling and placing all pipe sections and materials, excavation of the entire standard trench, bedding, and pipe backfill as described in the measurement section (both structural and embankment backfill in this region), removal of existing pipe to be replaced, constructing pipe joints, removal of old end treatments, cleaning out pipe, disposal of surplus materials, all visual inspection, and all incidentals necessary to complete the work.

Add the following paragraph to SC-M-714 subsections x.5:

Payment for riprap and geotextile for erosion control under riprap as measured in subsection x.4 includes all direct and indirect costs and expenses necessary to complete the work.

(53) SECTION 714: SMOOTH WALL PIPE:

REFERENCE:

SCDOT Supplemental Technical Specification SC-M-714

DESCRIPTION:

When bid items for smooth wall pipe are listed in the EBS file and/or proposal, the SCDOT will allow the use of reinforced concrete pipe, spiral ribbed aluminum pipe or high density polyethylene pipe in accordance with the specifications found in SC-M-714 (latest edition), the Standard Drawings, and this Special Provision. The plans may indicate reinforced concrete pipe only and are hereby superseded by this Special Provision.

MATERIALS:

Smooth wall pipe is either Reinforced Concrete Pipe (RCP: 714-205-XX), Spiral Ribbed Aluminum Pipe (SRAP: 714-605-XX), or High Density Polyethylene pipe (HDPE: 714-705-XX) as described in SCDOT Supplemental Technical Specification SC-M-714 and in the SCDOT Standard Drawings. Use smooth wall pipe culvert from manufacturers listed on Qualified Product Lists 30, 68, or 69. No value engineering application is required in order to use alternate pipe.

EXHIBIT 5 – SPECIAL PROVISIONS

For the following counties: Berkeley, Beaufort, Charleston, Colleton, Dorchester, Georgetown, Horry, and Jasper, provide pipe joints meeting AASHTO M 315 for RCP or passing the 13 psi pressure test as indicated on the QPL for SRAP or HDPE. Take care to properly lubricate and equalize pipe gaskets as indicated in the **SCDOT Standard Drawings** and **SC-M-714** to prevent gaskets from “rolling” during installation. For all other counties, provide pipe joints meeting AASHTO M 198, M 315, or passing the minimum 10 psi pressure test unless specific pipe joints are indicated in the plans or special provisions.

No other pipe type will be accepted as an alternate.

CONSTRUCTION REQUIREMENTS:

Use only pipe that conforms to the minimum and maximum fill height limitations indicated on the appropriate standard drawing. Unless indicated otherwise in the plans, determine pipe fill height based on the following formula:

Fill Height = Elevation (top of curb or max grade above pipe) – Elevation (pipe crown)

For all locations where new pipe is being attached to an existing system, use one of the following options:

1. Any existing pipe may be extended using any acceptable alternate pipe type by using a drainage structure at the interface between the different pipe types. The drainage structure* may consist of standard junction boxes, manholes, catch basins, drop inlets, or circular drainage structures detailed on **SCDOT Standard Drawings**. For larger diameter pipe, custom drainage structures may be required. Field cut existing pipe to remove damaged joint (if applicable) and install new drainage structure at the field cut interface. Always fully clean existing pipe and pipe joints before installing joint sealant or gaskets and attaching new pipe.
2. For locations where existing pipe properties cannot be directly matched, use a custom designed interface* (concrete collar, proprietary mastic wrap, custom coupling band, etc.) appropriate to interface the existing pipe to the new pipe of the same type. Submit interface drawings and design for review by the Engineer of Record and the Design Standards Engineer. Always fully clean existing pipe and pipe joints before installing joint sealant or gaskets and attaching new pipe. Replace existing pipe that has joint damage before connecting new pipe to the system.
3. Any existing pipe may be extended using new pipe with the same joint profile and wall properties of the existing pipe. Always fully clean existing pipe and pipe joints before installing joint sealant or gaskets and attaching new pipe. Verify* the following parameters before ordering new pipe:
 - a. For RCP to RCP, confirm wall thickness, joint profile shape, and compatibility with existing manufacturer’s pipe. Replace existing pipe that has joint damage before connecting new pipe to the system.
 - b. For SRAP to SRAP, replace existing pipe that has joint damage before connecting new pipe to the system.
 - c. For HDPE to HDPE, confirm the manufacturer of the existing pipe and the joint compatibility with the new pipe. Provide a new gasket when connecting to existing spigot end of HDPE pipe. Replace existing pipe that has joint damage before connecting new pipe to the system.
 - d. For CAAP to CAAP, confirm the type and size of end corrugations of the pipe. When existing pipe has full helical corrugations, provide new connecting pipe with one end fully helical and fully helical coupling band. When end corrugation size does not match the corrugation size shown on SCDOT Standard Drawings, provide a drainage structure (described above) at the interface. Replace existing pipe that has joint damage before connecting new

EXHIBIT 5 – SPECIAL PROVISIONS

pipe to the system. Do not install CAAP as smooth wall pipe; however, use these requirements when plans specify installing new CAAP.

The **RCE** will verify that connections between existing pipe and new installed pipe have been handled with one of the options listed above. Repair or replace all existing to new joint interfaces that do not meet the requirements above at no additional cost to **SCDOT**.

In all installations, provide the RCE with a complete pipe table indicating the following: Plan Pay Item, Plan Pipe Description, Plan Quantity, Installed Pipe (diameter, type, class/gage), Installed Quantity, and description of interface used to join new pipe to existing pipe for each occurrence.

In cases where 2 or more different pipe types are installed, provide a copy of the proposed installation layout on the drainage/plan sheets to the RCE indicating which pipe is installed at each location.

MEASUREMENT:

Measure smooth wall pipe in accordance with methods specified in SC-M-714 for the pipe material installed.

*No measurement will be made for drainage structure, designed interface, or field verification performed at each interface between existing pipe and new pipe unless drainage structure/interface is specified in the plans.

PAYMENT:

Payment will be made for smooth wall pipe regardless of the type of material installed. Payment for smooth wall pipe is as specified in SC-M-714 for the pipe material installed.

*Include all costs for work related to connecting new pipe to existing pipe in the unit bid price of the new pipe. This connection work includes: drainage structure at the interface, custom designed interface, field verification of existing pipe and compatibility with new pipe, new gaskets, new joint sealant, new coupling bands, removal, and disposal of damaged sections of existing pipe.

ITEM NO.	DESCRIPTION	UNIT
7143XXX	X" SMOOTH WALL PIPE	LF
7143XXX	X"x X" SMOOTH WALL PIPE CUL.TEE	EA
714XXXX	X" x X" SMOOTH WALL PIPE CUL.WYE	EA
7144XXX	X" SMOOTH WALL PIPE X DEG BEND	EA
7144XXX	SMOOTH WALL PIPE INCR.- X" TO X"	EA

(54) SECTION 720: DETECTABLE WARNING SURFACE:

Description:

Detectable warnings are an Americans with Disabilities Act (ADA) requirement for the purpose of detecting the boundary between the sidewalk and the street. The detectable warning surface is a feature built in or applied to walking surfaces to warn visually impaired people where to stop. Generally, they are used where the sidewalk crosses or adjoins a vehicular way and the two surfaces are not separated by a curb, rail or other element excluding un-signalized driveway crossings. Truncated domes are the only detectable warning surface allowed along with a visually contrasting surface.

Materials:

EXHIBIT 5 – SPECIAL PROVISIONS

The detectable warning surface consists of raised truncated domes with a base diameter of nominal 0.9 –1.4 inch, a height of nominal 0.2 inch and a center-to-center spacing of nominal 1.6 –2.4 inches. The pattern for the domes is a square pattern arranged in a parallel alignment. Minimum space between the domes at their base is 0.65 inch measured along any line of domes uniform over the entire detectable warning surface. See Standard Drawing 720-905-01 for details. Detectable warning surfaces must be listed on the Department’s Approval Sheet prior to installation.

Detectable warning surfaces visually contrast with the adjoining surfaces. The SCDOT has selected the color “safety yellow” (Federal Number 33538) to meet this requirement. If a specific project requires another color other than safety yellow, the color selected will contrast either light-on-dark or dark-on-light.

Construction:

Cast detectable warnings into the newly poured concrete ramps. If existing ramps are retrofitted, use the surface mount type of detectable warning. See Standard Drawing 720-905-02, 720-910-01 thru 04 for details.

Follow the manufacture’s instructions for the proper installation of detectable warning surfaces. Provide copies of the manufacturer’s literature to the Engineer to verify material and construction procedure compliance.

Method of Measurement:

The Engineer will measure detectable warnings by the square foot.

Basis of Payment:

Payment includes all costs for labor, materials, and incidentals to construct the detectable warnings in accordance with this Special Provision, Standard Drawings, and the manufacture’s requirements. The bid item, description, and unit are as follows:

Item number	Description	Unit
7204900	DETECTABLE WARNING SURFACE	SF

(55) SECTION 726: POLYMER MODIFIED ASPHALT EXPANSION JOINT SYSTEM

DESCRIPTION: This Special Provision shall govern the furnishing of materials and the installation of polymer modified asphalt expansion joint systems of the size, type and at the locations shown in the project plans as directed by the Engineer. A 5-year manufacturer warranty against surface cracks, and infiltration of moisture and water in the joint is also required.

SUBMITTALS: The Contractor shall submit the following to the RCE.

- a.) Manufacturer’s installation instructions and Product Data which indicates compliance with this specification.
- b.) The Contractor shall transfer the joint manufacturer’s 5-year warranty against surface cracks, infiltration of moisture and water, from the time the bridge is opened to the traffic to SCDOT. This written manufacturer’s warranty should contain SCDOT file number, estimated date the bridge will be opened to traffic and the following language:

“In the event surface cracks occur, before the warranty expires, the joint manufacturer will be responsible for repairing or replacing the joint at no cost. If the joint needs to be repaired or replaced by the manufacturer before the warranty expires, SCDOT will

EXHIBIT 5 – SPECIAL PROVISIONS

provide traffic control for a time interval specified by the joint manufacturer with 2 weeks notice”

MATERIALS: Materials used in the construction of the polymer modified asphalt joint system shall comply with the manufacturer’s recommendations, modifications of this Special Provision and as directed by the RCE.

- a) Backer Rod: The backer rod shall be of circular cross section and consist of closed-cell polyethylene foam expansion joint filler capable of withstanding the elevated temperature of the polymer modified asphalt. The diameter required will be 1.5 times the joint width as a minimum.
- b) Binder Coat: The binder coat shall be applied hot and be a type that is suitable for the intended use and be in accordance with the manufacturer’s recommendations.
- c) Bridging Plate: The metal used for bridging the joint opening shall comply with AASHTO M 270 Grade 36 (ASTM A 709 Grade 36). The use of aluminum for plates is strictly prohibited.
- d) Polymer Modified Asphalt Binder: The polymer modified asphalt binder system may be from the manufacturer listed below, or an approved equal.

Linear Dynamics, Inc.	The D.S. Brown Co	Watson Bowman
RR2 Box 311	PO 158 – 300 E. Cherry St	95 Pineview Dr
Muncy, Pa 17756	N. Baltimore, Ohio 45872	Amherst, NY 14228
Contact Sherry Willard	Contact Kyle Robinson	Contact Ron Poleon
Phone (1-570-547-1621)	Phone# (770) 998-4511	Phone# (770) 592-9021

CONSTRUCTION PROCEDURES: The following construction procedures shall be used in construction of joints. A manufacturer’s representative shall be present during all phases of the joint preparation and installation to ensure adherence to the manufacturer’s recommendations and procedures.

- a) Sawing and Surface Preparation: After paving operations are completed, the asphalt overlay is to be saw cut full depth, for the width shown in the plans, and the overlay material between the saw cuts removed down to the top of slab concrete. The exposed concrete surface shall be cleaned and dried as recommended by the joint manufacturer or as directed by the Engineer. The prepared and dried joint surface shall be inspected and approved before proceeding with additional operations.
- b) Backer Rod Installation: A proper sized backer rod shall be installed into the joint opening to a proper depth as directed by the manufacturer’s representative.
- c) Sealing Joint: Hot binder material shall be poured into the joint opening as directed by the manufacturer’s representative to seal joint.
- d) Bridging Plate: A proper size bridging plate shall be placed for the full length of joint.
- e) Binder-Coat Placement: A hot poured binder coat shall be applied to cover all exposed surfaces (both vertical and horizontal) of the joint and bridging plate as directed by the manufacturer’s representative.
- f) Aggregate Binder Matrix Placement: The binder material shall be placed in layers as directed by the manufacturer’s representative. The finished joint surface shall match the finished roadway surface.

EXHIBIT 5 – SPECIAL PROVISIONS

METHOD OF MEASUREMENT: Measurement of Polymer Modified Asphalt Expansion Joint will be taken along the centerline of joint from gutter line to gutter line. Payment for the measured length will be full compensation for any additional extension required to terminate the joint beyond the gutter lines.

BASIS OF PAYMENT: Payment for the joint will be at the linear foot price bid for the item "Polymer Modified Asphalt Expansion Joint", which payment will include the cost of furnishing and installing the joint system and all labor, materials, tools, hardware, equipment, furnishing manufacturer's technical representative, cost for maintenance of traffic for a time interval as specified by the manufacturer for curing of the joint material and all incidentals necessary to complete the work.

Payment will be made under:

ITEM NO.	PAY ITEM	PAY UNIT
7261210	Polymer Modified Asphalt Expansion Joint	L.F.

(56) SECTION 727: CROSSHOLE SONIC LOGGING OF DRILLED SHAFT FOUNDATIONS:
Crosshole Sonic Logging (CSL) Testing is required for all drilled shafts. SCDOT shall be responsible for all CSL Testing.

(57) SECTION 805: GUARDRAIL END TERMINAL - TYPE T:
The Contractor's attention is directed to the plans which call for Guardrail End Terminal Type T. These end treatments shall meet the requirements of NCHRP 350. The Contractor shall select a terminal listed on the Qualified Products List for "End Terminal - Type T". This list is maintained by the Materials and Research Engineer. Currently, the following two terminals are listed on the Qualified Products List:

ET - PLUS
SKT - 350

The Contractor shall construct the end terminal in accordance with the manufacturer's specifications for a four tube system. End Terminals are to be supplemented with a W18-1R-30 or W18-1L-30 sign as appropriate. The sign is to be fabricated from Type III sheeting with a high tack adhesive and attached directly to the end terminal without the aluminum blank. All costs for the sign and installation are to be included in the price bid for Guardrail End Terminal Type T.

Note: The Melt does not meet the NCHRP 350 criteria.

(58) SECTION 805: HEIGHT OF W-BEAM GUARDRAIL:
The Standard Drawings for w-beam guardrail are hereby revised as follows:

Install standard w-beam guardrail at a minimum height of 27.75 inches, measured from the ground line to the top of the rail at the front face of the rail. A construction tolerance of three inches above this height is allowed. Ensure the final height of w-beam guardrail is within the acceptable range of 27.75 inches to 30.75 inches.

(59) SECTION 805: GEOCOMPOSITE WALL DRAIN DATED MAY 6, 2003:

1.0 DESCRIPTION

EXHIBIT 5 – SPECIAL PROVISIONS

A geocomposite wall drain is a prefabricated drain system that is used to provide drainage behind retaining walls. The geocomposite drain consists of a flexible plastic drainage core bonded to a non-woven geotextile. Geocomposite wall drains shall be placed continuously along the back of the wall as shown in the plans or as otherwise directed by the Engineer. The Contractor shall furnish all necessary labor, equipment, and materials and perform all operations necessary for the installation of geocomposite wall drains in accordance with the details shown on the plans and with the requirements of this specification.

2.0 ACCEPTANCE CRITERIA

The Contractor shall supply to the Engineer, prior to placing the material, certified test results of those tests specified herein from a recognized laboratory. Acceptance will be based on the test results meeting the geocomposite system properties, drainage core properties, and geotextile properties stated in this specification. The Engineer shall submit the certified test results to the Research and Material Engineer for acceptance. Test data shall be no more than one year old at the time it is furnished to the Department. Geocomposite wall drains shall not be installed until the material certification is received and approved by the Research and Materials Engineer. The Department reserves the right to sample and test any of the materials used in the geocomposite wall drain system.

Labeling, shipment, and storage of the geocomposite wall drain materials shall follow ASTM D 4837. Product labels shall clearly show the manufacturer or supplier name, style number, and roll number. Geocomposite rolls shall be wrapped with a material that will protect the geocomposite drain from damage due to shipment, water, sunlight, and contaminants. The protective wrapping shall be maintained during periods of shipment and storage.

3.0 MATERIAL

The geocomposite wall drain shall be prefabricated type made up of a lightweight, high impact polymeric drainage core bonded to the geotextile at intervals not exceeding 1.5 inches. The geocomposite wall drain shall be solid backed allowing drainage of water on only one side. The non-woven geotextile is thermal (heat) bonded or fungicide glue bonded to the polymeric drainage core. The geocomposite product sheets or rolls shall have a minimum width of 3 feet with a minimum coverage area of 40 square feet. A geotextile flap shall be provided along all drainage core edges. This flap shall be of sufficient width for sealing the geocomposite drain edge to prevent soil intrusion into the drainage core during and after installation. The geotextile shall cover the full length of the drainage core.

The wall drainage system shall meet the following geocomposite system properties in addition to the individual component properties of the polymeric drainage core and the non-woven geotextile. All numerical values listed in the required property tables shown below represent minimum average roll values (MARV) per ASTM D 4759 unless indicated otherwise. Values for the weaker principal direction should be used. Testing shall be performed in accordance with the methods referenced in this specification. Sampling of lots shall be in accordance with ASTM D 4354.

GEOCOMPOSITE SYSTEM PROPERTIES		
TEST	METHOD	LIMIT

EXHIBIT 5 – SPECIAL PROVISIONS

Flow Capacity (gpm/ft. width) At a hydraulic gradient of 1.0 and a minimum normal stress of 3600 psf (Normal load maintained for 300 hours or until equilibrium)	ASTM D 4716	14
--	-------------	----

DRAINAGE CORE PROPERTIES

TEST	METHOD	LIMIT
Thickness (inches)	ASTM D 1777	0.3 minimum / 0.5 maximum
Compressive Strength (psf) At 20% Deformation (10,000 hour minimum duration)	ASTM D 1621	14,000

GEOTEXTILE PROPERTIES

TEST	METHOD	LIMIT
AOS (Equiv. U.S. Sieve)	ASTM D 4751	50 maximum average roll value
Permittivity (sec ⁻¹)	ASTM D 4991	1.0
Grab Tensile Strength (lbs.)	ASTM D 4632	80
Grab Tensile Elongation (%)	ASTM D 4632	50
Trapezoidal Tear Strength (lbs.)	ASTM D 4533	40
Puncture Strength (lbs.)	ASTM D 4833	50
Burst Strength (psi)	ASTM D 3786	150
Ultraviolet Stability (%) (Retained strength after 500 hours of exposure)	ASTM D 4355	70

4.0 CONSTRUCTION REQUIREMENTS - GENERAL

The Contractor shall check the geocomposite wall drain upon delivery to ensure that the proper material has been received. The geocomposite wall drain shall be protected during shipment and storage at the construction site from temperatures greater than 71° C, mud, dirt, debris, and any other environmental condition that may damage the material's physical property values. The wall drainage system shall be protected from direct sunlight in accordance with the manufacturer's recommendations.

The geocomposite wall drain will be rejected at the time of installation if it has defects, tears, punctures, flaws, deterioration, or damage incurred during manufacture, shipment, or storage. Torn or punctured sections shall be removed or repaired as directed by the Engineer. Any geocomposite wall drain damaged during manufacture, shipment, or storage shall be replaced by the Contractor at no additional cost.

If at any time the Engineer determines that the method of installation does not produce a satisfactory wall drainage system, the Contractor shall alter his method and/or equipment as necessary to comply with this specification.

The geocomposite wall drain shall be installed in accordance with the plans and specifications. The surface that the geocomposite drain will be placed against shall be cleaned by removing all soil, debris, and irregularities that will prevent intimate contact between the surface and the geocomposite drain. The geocomposite wall drain shall be secured to the wall using metal stick clips, adhesives, or as recommended by the manufacturer. The geocomposite wall drain shall be installed so

EXHIBIT 5 – SPECIAL PROVISIONS

as to allow weepholes, as shown in the plans, to drain water from the drainage core and underdrain pipes.

All joints shall be formed by peeling or trimming the geotextile off the attached section to expose 3 inches of the drainage core. The drainage core of the second section being attached is then overlapped 2 inches over the first drainage core. The joint is then covered by reattaching the geotextile flap and securely fastening it to the lower geotextile by means of a continuous strip of 3 inch wide waterproof plastic tape. Each overlapping course shall be shingled in the direction of water flow. If joints cannot be formed by interlocking the cuspatations, then the drainage core should be butted together and covered with continuous, 6 inch wide geotextile. The geotextile fabric shall be centered over the joint and securely fastened to the two geocomposite drains with 3 inch wide waterproof plastic tape.

All exposed edges of the geocomposite wall drain shall be covered with geotextile by tucking and securing a minimum of 4 inches of geotextile behind the drainage core. This may be done by using the geotextile flaps at the edges or using a 12 inch wide continuous strip in the same manner, taping it to the exposed fabric 4 inches in from the edge with a continuous strip of 3 inch wide waterproof plastic tape, and folding the remaining geotextile and tucking it behind the drainage core edge.

If the geotextile is torn, perforated, or ripped during installation, it shall be patched or replaced as directed by the Engineer. The damaged section shall be cut out and replaced completely or repaired by placing a piece of geotextile over the damaged area and providing a minimum of 4 inches of overlap on all sides over the damaged area and secured with 3 inch wide waterproof plastic tape. Damaged drainage core sections shall be discarded and replaced. Any geocomposite wall drain damaged during installation shall be replaced or repaired by the contractor at no additional cost.

The underdrain pipes and free draining aggregate shall be placed as shown in the plans or as directed by the Engineer. A positive outlet for the water in the geocomposite drain shall be maintained at all locations. Weepholes shall not be sealed or made ineffective by the wall drain material. This may involve making a hole in the drainage core at the weephole location. The geotextile drainage filtration fabric used to envelop the underdrain system shall be tucked 6 inches behind the geocomposite drain and overlapped over the geocomposite drain a distance of 12 inches and continuously secured with 3 inch wide waterproof plastic tape.

Backfill shall be placed immediately over the geocomposite wall drain. The contractor shall backfill against the wall in a manner that does not damage the geocomposite drainage system. Care shall be taken to avoid excessive settlement of the backfill material. The geocomposite wall drain shall not be exposed for more than seven days prior to backfilling. Any geocomposite drainage system component that is damaged during the backfilling operation shall be replaced or repaired as directed by the Engineer.

5.0 METHOD OF MEASUREMENT AND BASIS OF PAYMENT

Geocomposite wall drains will not be measured for payment. The cost of the geocomposite wall drain shall be included in the cost of the retaining wall or wall system where the drainage system is being installed.

(60) SECTION 805: GEOTEXTILE FOR DRAINAGE FILTRATION:
See attached Supplemental Specification dated **October 15, 1991** in **Exhibit 6**.

(61) SECTION 805: COLD APPLIED WATERPROOFING DATED MAY 29, 2003:

EXHIBIT 5 – SPECIAL PROVISIONS

1.0 DESCRIPTION

A cold applied waterproofing system may be used in lieu of the “Second Method” waterproofing. The cold applied waterproofing shall be placed along construction joints and contraction joints that are adjacent to soil. The cold applied waterproofing shall be placed continuously along the joints in the wall as shown in the plans or as otherwise directed by the Engineer. The Contractor shall furnish all necessary labor, equipment, and materials and perform all operations necessary for the installation of cold applied waterproofing system in accordance with the details shown on the plans and with the requirements of this specification.

2.0 ACCEPTANCE CRITERIA

The Contractor shall supply to the Engineer, prior to placing the material, certified test results of those tests specified herein. Acceptance will be based on the material test results meeting the properties stated in this specification. The Engineer shall submit the certified test results to the Research and Material Engineer for acceptance. Test data shall be no more than one year old at the time it is furnished to the Department. The waterproofing shall not be installed until the material certification is received and approved by the Research and Materials Engineer.

3.0 MATERIAL

The cold applied waterproofing system shall be a self-adhering membrane of rubberized asphalt integrally bonded to polyethylene sheeting. The material shall conform to the properties given in the table below.

COLD APPLIED WATERPROOFING SYSTEM PROPERTIES		
TEST	METHOD	LIMIT
Application Temperature Range (°F)	N/A	40 °F to 120 °F
Minimum Thickness (mils)	N/A	60
Pliability (180 bend over ¼” mandrel @ - 25 °F)	ASTM D 146	No Effect
Minimum Tensile Strength – Film (psi)	ASTM D 412 (Die C) Modified	4000
Minimum Elongation – Ultimate Failure of Rubberized Asphalt, (%)	ASTM D 412 (Die C) Modified	300
Minimum Puncture Strength – Membrane (Stretches by blunt object) (lbs.)	ASTM E 154	40
Minimum Puncture Strength – Film (in ounce tear) (lbs.)	ASTM D 781	250
Maximum Permeance – Perms (Grains/sq. ft./hr./in.Hg)	ASTM E 96 (Method B)	0.1
Maximum Water Absorption (% by weight)	ASTM D 570	0.2
Minimum Tensile Strength – Membrane (psi)	ASTM D 412 (Die C) Modified	250

4.0 CONSTRUCTION REQUIREMENTS - GENERAL

EXHIBIT 5 – SPECIAL PROVISIONS

The Contractor shall check the cold applied waterproofing system upon delivery to ensure that the proper material has been received. All materials shall be delivered to the site in the original containers, plainly marked with the manufacturer's brand or label. The waterproofing materials shall be stored in a dry protected place. Manufacturer's recommendations for shipping and storage at the construction site shall be followed.

The waterproofing materials will be rejected at the time of installation if it has defects, tears, punctures, flaws, or damage incurred during manufacture, shipment, or storage. Any waterproofing materials damaged during manufacture, shipment, or storage shall be replaced by the Contractor at no additional cost.

The cold applied waterproofing shall be installed in accordance with the manufacturer's recommendations at the locations shown on the plans or as directed by the engineer. If at any time the Engineer determines that the method of installation does not produce a satisfactory waterproofing, the Contractor shall alter his method and/or equipment as necessary to comply with this specification.

5.0 METHOD OF MEASUREMENT AND BASIS OF PAYMENT

Cold applied waterproofing shall not be not be measured for payment. The cost of the cold applied waterproofing shall be included in the cost of the retaining wall or wall system where the waterproofing is being installed.

(62) SECTION 809: RIGHT OF WAY PLAT:

Description:

The Contractor by the "Substantial Work Complete" date shall prepare a right of way plat signed and sealed by a Professional Land Surveyor (PLS) licensed to practice in the state of South Carolina. The right of way plat shall be in accordance with the requirements of Section 49-460-A "General Property Survey" as outlined in the South Carolina "Standards of Practice Manual" for land surveyors. A copy of the plat will be recorded, by the contractor, in the Register Mesne Conveyance (RMC) office of the county or counties in which the project resides. The Contractor will provide one copy of the plat on a full sized plan sheet(s) (22" X 36") and submit to the resident construction engineer to be included in the as-built plans.

Materials: Rebar Cap R/W Marker

Materials used shall comply with those listed on SCDOT Standard Drawing No. 809-105-00.

Construction Requirements:

The PLS shall set right of way markers along all new right of way lines as well as along any present right of way being retained by the Department at intervals listed on the SCDOT Standard Drawings. Right of way markers shall not be placed at points common to side property lines and/or corners. In the event that the plan reflects a break in the right of way along a side property line the right of way marker will not be set without the side property line being retraced and established by way of survey. The PLS shall prepare a plat documenting the location of all right of way markers set and reflecting the as-built station and offset from the plan alignment. The plat shall show the entire project corridor as an enclosed strip or parcel of land to include the mainline and all side roads as defined on the project plan.

Measurement and Basis of Payment:

The item Right of Way Plat is paid on a lump sum (LS) basis; and therefore, there is no specific measurement for this item. The unit price bid for Right of Way Plat shall include all costs for labor, materials, equipment, services of a PLS and any related fees or costs associated with producing a plat, recording the plat at the RMC office, and all required copies. Each marker placed in accordance with the Standard Drawing complete and accepted will be measured and paid at the unit price bid.

EXHIBIT 5 – SPECIAL PROVISIONS

Item No.	Description	Unit
8091000	RIGHT OF WAY MARKER (REINFORCED CONCRETE)	EA
8091010	RIGHT OF WAY MARKER (REBAR AND CAP)	EA
8091050	RIGHT OF WAY PLAT	LS

(63) SECTION 810: SEEDING:

Section 810.2.2.3 is hereby amended by adding the following note to the table:

² The use of Annual Sudan Grass for temporary vegetation shall be prohibited statewide.

The first paragraph of Section 810.4.3 is amended to read as follows:

1 Before acceptance of the seeding performed for the establishment of permanent vegetation, the Contractor will be required to produce a satisfactory stand of perennial grass sufficient to control erosion. It will not be necessary for the grass to re-establish after dry periods or winter weather for acceptance and payment to be made.

(64) SECTION 815: EROSION CONTROL MEASURES:

In addition to the erosion control measures specified in the Plans, Standard Specifications, Supplemental Technical Specifications and the Special Provisions, the Contractor is advised that all land disturbing activities (clearing and grubbing, excavation, borrow and fill) are subject to the requirements set forth in the following permits and regulations:

- South Carolina Code of Regulations 63-380, Standard Plan for Erosion, Sediment, and Stormwater Runoff Control.
- Erosion and Sediment Reduction Act of 1983 (Title 48, Chapter 18 of the South Carolina Code of Laws of 1983, as amended). Section 70 of this code authorized the South Carolina Department of Health and Environmental Control (SCDHEC) to administer this regulation with respect to lands under the jurisdiction of the South Carolina Department of Transportation.
- National Pollutant Discharge Elimination System (NPDES) General Permit Number SCR160000, effective January 1, 2013: The Environmental Protection Agency, in accordance with the Federal Clean Water Act, has granted to the South Carolina Department of Health and Environmental Control (SCDHEC) the authority to administer the Federal NPDES permit program in the State of South Carolina.

In accordance with the NPDES General Permit, the Contractor must sign a Contractor Certification. The certification is incorporated into the proposal form for the Contract. By signing this form, the Contractor acknowledges that upon award and execution of the Contract, he/she accepts/understands the terms and conditions of the *Storm Water Pollution Prevention Plan (SWPPP)* as required by the NPDES General Permit and may be legally accountable to SCDHEC for compliance with the terms and conditions of the *SWPPP*. In addition, the Contractor certifies that the NPDES certification statement status is made part of all its subcontracts.

The Contractor will complete and forward an updated SCDOT approved *Notice of Intent (NOI)* to the SCDOT Construction office to submit to SCDHEC. If the Coastal Zone Consistency (CZC) permit has not been approved it shall be forwarded by the Contractor to SCDOT to submit to SCDHEC as part of *NOI* package. If SCDHEC does not send a letter within 10 business days of receipt of the *NOI*, authorizing coverage, denying coverage, or advising that a review of the *CECP* will take place, coverage will be automatically granted.

Prepare and submit a *Contractor's Erosion Control Plan (CECP)* to the RCE before the pre-construction conference. Ensure that the plan meets the requirements of the NPDES General

EXHIBIT 5 – SPECIAL PROVISIONS

Permit. The plan will be reviewed and approved by the Department before commencing any land disturbing activities.

At the pre-construction conference, with contactors performing land-disturbing activities present, the *CECP* will be explained and discussed so that the Contractor is made aware of their responsibilities in the *CECP*.

Once approved, fully implement the *CECP*. Coordinate the prompt installation of erosion control devices with construction activities to maintain compliance with the above regulations and NPDES General Permit.

Conduct an Erosion and Sediment Control Inspection by an appointed Certified Erosion Prevention and Sediment Control Inspector (CEPSCI) from the Contractor and the Department at least every 7-calendar days. Both parties will acknowledge participation in the inspection by signing the inspection report and include their inspector's CEPSCI number on the report. Correct deficiencies noted during these inspections within the assigned priority period. If deficiencies are not corrected within this timeframe, the RCE will stop all work (except erosion and sediment control measures) until the deficiencies are corrected.

Give special attention to critical areas within the project limits (i.e., running streams, water bodies, wetlands, etc.). In these areas, the RCE may direct the Contractor to undertake immediate corrective action, but in no case allow these deficiencies to remain unresolved more than 7 days or 48 hours in accordance with their assigned priority after being identified during the Erosion and Sediment Control Inspection.

Closely follow the grading operations with the seeding operations. Shape and prepare the slopes for seeding as the grading progresses. Unless the RCE grants prior written approval, limit the amount of surface area exposed by land disturbing activities to 750,000 square feet. Commence seeding operations within 7 days following completion of construction activities within an area.

Initiate stabilization measures within 7 days for an area where construction activities will be temporarily or permanently ceased for 14 days or longer.

Coordinate the installation of all other permanent erosion control items with the grading and seeding operations. These items include, but are not limited to, asphalt gutter and riprap. Construct gutter work before or promptly after the seeding is performed. Place riprap at the ends of pipe immediately after the pipe is laid and promptly install riprap ditch checks after ditch work has been performed.

Failure to adequately comply with the provisions as detailed above or any other required erosion control measures will result in stoppage of all contract operations (except erosion and sediment control measures) until corrective action has been taken. Additional sanctions may be invoked by the SCDHEC in accordance with their authority.

Keep the following documents at the RCE's office from the start of construction until the site is finally stabilized:

- Copy of the *CECP*,
- Copies of Contractor Certification statements,
- Copy of the permit,
- Letter from DHEC authorizing permit coverage if provided by SCDHEC, and
- A marked-up set of site plans.

When uniform perennial vegetation achieves a cover density of 70%, submit a *Notice of Termination (NOT)* to SCDHEC to terminate coverage. Include a signed statement with the *NOT* certifying that all work on the site has been completed in accordance with the *SWPPP* and the NPDES General Permit for all sites one acre or greater.

EXHIBIT 5 – SPECIAL PROVISIONS

Fines assessed on the Department by SCDHEC as the result of the Contractor's non-compliance or violation of said permit provisions will be paid by the Department and will subsequently be deducted from any monies due or that may become due to the Contractor. In case no monies are due or available, the fines incurred will be charged against the Contractor's Surety.

EXHIBIT 5 – SPECIAL PROVISIONS

Contractor Certification Form

Date: _____

A. Project Information

NPDES Coverage No.: SCR _____ State Permit (Tracking) No.:

Project/Site Name (As Approved by Department):

3. Owner/Operator Name: South Carolina Department of Transportation (SCDOT)

B. Contractor Information

1. Name: _____ Title/Position: _____

Mailing Address: _____ City: _____ State: _____ Zip: _____

Company Name (As Applicable):

Phone: _____ Email Address: _____

2. Describe Construction-Related Responsibilities & Activities (linear construction, facility construction)

C. Contractor Certification Statements & Agreement: (Read the Contractor Certification statements below (in entirety) and provide date and signature of agreement below). See Section 122.22 of S.C. Reg. 61-9 for signatory authority requirements. DO NOT SIGN IN BLACK INK!

"I certify by my signature below that I or I (on behalf of my company and its contractors and agents), as the case may be, Understand, accept, and will adhere to the provisions of the Stormwater Pollution Prevention Plan (SWPPP) as it pertains to the portion of the project I am or my company is responsible for, and as required by the coverage under the National Pollutant Discharge Elimination System (NPDES) General Permit for Stormwater Discharges From Construction Activities SCR160000 issued to SCDOT of the construction activity with whom I am or my company is under contract to perform construction related professional services; Am legally accountable to the SC Department of Health and Environmental Control (DHEC), under the authorities of the Clean Water Act and the SC Pollution Control Act, to ensure compliance with the terms and conditions of the SWPPP applicable to my or my company's portion of the project; Must comply with the terms and conditions of the SCDOT Construction General Permit (SCDOT CGP), will adhere to applicable standards and stormwater erosion control practices established in the SWPPP, the Best Management Practices (BMP) manual, and SCDOT Standard Specifications at all times while performing work at the project site, and agree to implement corrective actions identified by the qualified inspector during a site inspection; and Understand that DHEC enforcement actions may be taken against the permittee, the contractor or both if the terms and conditions of the SWPPP are not met.

Therefore, having understood the above information, I am signing this certification as contractor to the aforementioned NPDES general permit."

Printed Name of Contractor Title/Position

Signature of Contractor Date Signed

Termination of Contractor Certification Agreement: DO NOT SIGN IN BLACK INK! (When the permitted construction project has reached final acceptance by SCDOT, sign and date below)

Signature of Contractor Date Signed

DHEC 0437 (10/2012)

(65) SAFETY FENCE:

Safety Fence

Description

This work consists of furnishing materials, installing, and maintaining safety fence to mark all jurisdictional boundaries within a project corridor. Additionally where appropriate the contractor should hang highly visible flagging to outline the jurisdictional boundaries. The fence and flagging shall be installed prior to any land disturbing activities.

Materials

Polyethylene or polypropylene fence shall be an orange preconstructed safety fence approved by the Engineer. The fence shall be furnished with an ultraviolet coating and protected against moisture and extended ultra-violet exposure prior to placement. Either wood or steel posts may be used. Install safety fence using wooden stakes (1 inch x 1 inch) or steel posts (1.25 lbs/ linear foot) a minimum of five (5) feet in length.

Construction

No additional clearing and grubbing is anticipated for the installation of the safety fence. The fence shall be erected along and around the existing ground contour and vegetation.

Place survey stakes with high visibility flagging on 25' feet maximum intervals along the jurisdictional boundary. With the boundary established, install the orange safety fencing parallel to and offset 10 feet from the outside perimeter of all jurisdictional boundaries. The safety fence may be installed on a tangent that runs parallel to the buffer but must not encroach on the buffer at any location. Post shall be set on a maximum of 10 feet spacing.

Wetland flagging tape should be placed on adjacent vegetation to assist contractors in recognizing the jurisdictional boundaries.

The contractor shall maintain the safety fence in satisfactory condition for the duration of the project as determined by the RCE.

(66) DIVISION 200: SETTLEMENT PLATES:

1.1 Scope

The work under this Section consists of furnishing all supervision, labor, material, equipment, and related services necessary to furnish and install settlement plates as indicated on the Drawings and specified herein. The Contractor shall accommodate the Engineer in the monitoring of settlement plates.

The purpose of the settlement-monitoring program is to:

1. Confirm estimates of the time rate of settlement of embankments and retaining walls during construction so that construction methods may be adjusted, if necessary, to meet the project schedule;
2. Confirm that settlement is sufficiently completed prior to final grading and paving of roadways supported on embankments and retaining walls.

Consolidation settlement of the foundation soils is expected to occur during and for a period after construction of new embankments and retaining walls. The magnitude and rate of the settlement will depend on the variation of the stratigraphy and consolidation properties of the foundation soils. To effectively manage the post-construction settlement,

EXHIBIT 5 – SPECIAL PROVISIONS

settlement plates shall be used to monitor the magnitude and rate of settlement during construction.

Settlement plates shall be furnished and installed by the Contractor in the presence of the Engineer. Settlement plates shall consist of a steel plate with coupling for attaching the central rod and protective PVC casing. A benchmark shall be established on stable ground that is not subject to settlement.

1.2 Responsibilities of Contractor:

The Contractor shall notify the Engineer at least five (5) working days prior to the installation of settlement plates.

The Contractor shall furnish and install the settlement plates in the presence of the Engineer.

The Contractor shall provide a licensed surveyor to stake out and provide as-built locations and elevations of all settlement plate locations and benchmarks.

The Contractor shall protect the settlement plates and benchmarks from damage for the duration of the Contract.

The Contractor shall provide the Engineer safe access to the settlement plates for the purpose of data collection for the duration of the Contract.

The Contractor shall be responsible for locating all settlement plates in the field and ensuring that no conflicts exist between settlement plates and existing and proposed structures, utilities or other construction proposed or present at the site.

1.3 Site Preparation

The Contractor shall ensure a firm base on which heavy equipment and/or other necessary equipment can be operated safely under its own power for installation of settlement plates.

The Contractor shall accurately locate all settlement plates in accordance with Drawings. Settlement plates may be adjusted by the Contractor, with the approval of the Engineer, to avoid utilities, foundations, and all other underground construction.

1.4 Existing Soil Conditions:

The subsurface conditions encountered at the site are presented in the Contract Plans and documents.

2.0 PRODUCTS

2.1 Settlement Plate

The settlement plate shall consist of a 30-in. square, 1/2-in. thick steel plate with a coupling centered on the plate for attaching a central steel rod. In addition, the plate shall have a means for keeping the protective PVC casing centered on the steel rod.

2.2 Central Steel Rod

A central steel rod shall extend from the plate vertically to allow for measurements of the elevation of the settlement plate. The rod shall be of sufficient diameter to prevent buckling or swaying over the height of the fill. In addition, the rod will either be threaded at both ends or will be threaded rod to allow for the addition of extensions. The central steel rod

EXHIBIT 5 – SPECIAL PROVISIONS

will include the necessary couplers to allow for the extension. Metal pipe may be substituted for the rod, provided the pipe is manufactured from similar material as the settlement plate.

2.3 Protective PVC Casing

A schedule 40 PVC pipe shall be installed around the central steel rod to protect the rod from compaction operations. The PVC casing will have an inside diameter of no less than 3 inches. The casing may have either glued or threaded joints. The joints should form a watertight seal. A protective cap shall be placed at the top of the PVC casing to prevent soil, water and other debris from being introduced into the casing. In addition, the casing shall extend a minimum of 1 foot and no more than 5 feet above the ground surface at the base of casing during fill placement. Further, the contractor shall visibly identify the location of the PVC casing to prevent damage to the casing during the placement of fill materials.

2.4 Incidentals

Incidental hardware, fasteners, tools, and the like, as necessary to install the system in accordance with these specifications, shall be provided.

3.0 SUBMITTALS

The Contractor shall submit a plan for the settlement plates indicating where the coupling and protective casing supports are to be located and the method to be used to attach the coupling and casing supports.

Within 1 week following installation, the contractor shall submit an installation record for each settlement plate, which includes the plate designation, station, offset, and elevation of the Settlement plate. The settlement plate shall be located to an accuracy of 0.01 ft (both vertically and horizontally).

4.0 EXECUTION

4.1 Settlement Plate Installation

The Contractor shall furnish and install settlement plates in accordance with the Drawings and these specifications and in the presence of the Engineer. Settlement plates shall be installed prior to embankment or retaining wall construction and following installation of wick drains, stone columns, or other ground improvement, and grubbing and clearing in the immediate vicinity of each settlement plate. The Contractor, only with the approval of the Engineer, may adjust settlement plate locations. The settlement plates shall be placed on a firm, level area as indicated in the plans.

4.2 Allowance for Settlement Plate Monitoring

The Contractor shall accommodate the Engineer during construction to provide safe and timely access to settlement plates for the purpose of obtaining measurements, as construction progresses. The Contractor shall retain a licensed land surveyor to monitor the settlement of the plates. Evaluation of the settlement plate data will be the responsibility of the Engineer.

4.3 Fill Height Survey

The Contractor shall make a survey of the central rods daily while fill is being placed, and twice weekly after completion of fill placement, unless directed otherwise by the Engineer. Additionally, surveys shall be made at the addition of an extension rod. The

EXHIBIT 5 – SPECIAL PROVISIONS

measurements shall be obtained both before and after the addition of the extension rod. Surveys made by the Contractor shall be provided to the Engineer within one week. In addition, the Contractor shall provide all readings as the elevation of the plate to the nearest 0.01 ft. Further the Contractor will provide the temperature in degrees Fahrenheit (°F) and the time (actual) of obtaining the settlement plate elevations.

4.4 Protection of Settlement Plates

The Contractor shall protect settlement plates from damage and vandalism for the duration of the Contract and repair or replace damaged or inoperative settlement plates at no cost to the Department.

4.5 Abandonment of Settlement Plates

Once the Engineer has determined that the settlement plates have served their purpose and are no longer needed, they shall be abandoned in-place. The Contractor shall remove as much of the central steel rod as can be recovered and shall cut the PVC casing off two feet beneath the finished subgrade. The Contractor shall fill the PVC casings remaining in the ground with lean grout and shall place two feet of properly compacted fill on top of the testing location.

5.0 METHOD OF MEASUREMENT

The number of settlement plates, as provided in the plans, will be paid for at the contract unit price bid for "Monitoring Device - Settlement Plates" which shall include all equipment, including but not limited to the settlement plates; mobilization; labor; surveys; materials; incidentals and abandonment required by these Specifications.

6.0 BASIS OF PAYMENT

The price and payment for this work shall be full compensation for furnishing the necessary Settlement Plates, including the settlement plates, surveys and incidental items based on the acceptance of the Settlement Plate installation by the Engineer.

Payments shall be made under:

Item No.	Pay Item	Pay Unit
2038110	MON. DEVICE – SETTLEMENT PLATE	EA

EXHIBIT 5 - SPECIAL PROVISIONS

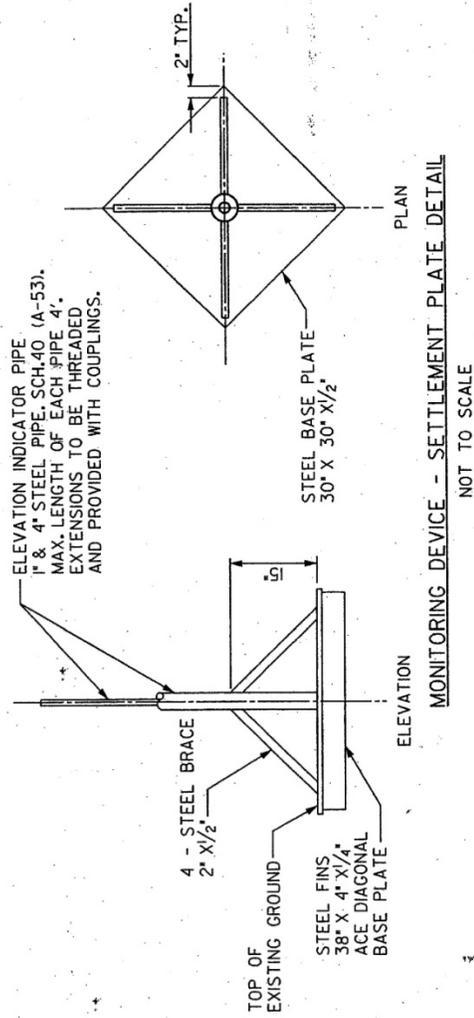

MONITORING DEVICE - SETTLEMENT PLATE DETAIL
NOT TO SCALE

(67) NONWOVEN GEOTEXTILE INTERLAYER FABRIC FOR CONCRETE PAVEMENT:

This Special Provision describes the construction and material requirements for installation of an interlayer fabric to be used between concrete pavement and cement stabilized aggregate base.

REFERENCED DOCUMENTS

ASTM D 4355 *Standard Test Method for Deterioration of Geotextiles by Exposure to Light, Moisture and Heat in a Xenon Arc Type Apparatus*

ASTM D 4491 *Standard Test Methods for Water Permeability of Geotextiles by Permittivity.*

ASTM D 4595 *Standard Test Method for Tensile Properties of Geotextiles by the Wide-Width Strip Method.*

ASTM D 4716 *Standard Test Method for Determining the (In-plane) Flow Rate per Unit Width and Hydraulic Transmissivity of a Geosynthetic Using a Constant Head.*

ASTM D 5199 *Standard Test Method for Measuring the Nominal Thickness of Geosynthetics.*

ASTM D 5261 *Standard Test Method for Measuring Mass per Unit Area of Geotextiles.*

1. GENERAL

1.1. Provide and install a non-woven geotextile interlayer to be placed between concrete pavements and cement stabilized aggregate bases. The fabric is intended to provide limited drainage, separation between the base and pavement to retard the transmission of cracking, and relief of bedding stress due to movement of the concrete pavement on a stiff base. Attach the fabric firmly to the base to prevent movement during paving operations. Conduct paving operations to minimize fabric damage due to vehicle movements. Repair any damage prior to paving to ensure complete coverage of the base.

2. MATERIAL REQUIREMENTS

2.1. Geotextile requirements:

2.1.1. Fabric type: Provide a nonwoven needle-punched geotextile. Thermal treatment (calendering or IR) is not acceptable.

2.1.2. Color: Ensure that the color is uniform and uses nominally the same color fibers throughout.

2.1.3. The following requirements must be met by 95% of samples. Minimum Average Roll Values (MARV) are also acceptable:

2.1.3.1. Mass per unit area: Ensure that mass per unit area is greater than 450 grams per square meter (13.3 ounces per square yard) and less than or equal to 550 grams per square meter (16.2 ounces per square yard) when tested in accordance with ASTM D 5261.

EXHIBIT 5 - SPECIAL PROVISIONS

- 2.1.3.2. Thickness under load (pressure): Ensure that the thickness under load is greater than or equal to 3.0 mm at 2 kPa (0.12 inch at 0.29 psi), greater than 2.5 mm at 20 kPa (0.10 inch at 2.9 psi), and greater than 1.0 mm at 200 kPa (0.04 inch at 29 psi) when tested in accordance with ASTM D 5199.
- 2.1.3.3. Wide-width tensile strength: Ensure the tensile strength is greater than 10 kN per meter (685 pounds per foot) when tested in accordance with ASTM D 4595.
- 2.1.3.4. Maximum elongation: Ensure that the maximum elongation is less than or equal to 60 percent when tested in accordance with ASTM D 4595.
- 2.1.3.5. Water permeability in normal direction under load (pressure): Ensure that the water permeability in the normal direction under load (pressure) is greater than or equal to 1×10^{-4} meters per second (3.3×10^{-4} feet per second) when tested in accordance with modified ASTM D 4491 at 20 kPa (2.9 psi).
- 2.1.3.6. In-plane water permeability: Ensure that the in-plane water permeability (transmissivity) under load (pressure) is greater than or equal to 5×10^{-4} meters per second (1.6×10^{-3} feet per second) when tested in accordance with modified ASTM D 4716 at 20 kPa (2.9 psi) and is greater than or equal to 2×10^{-4} meters per second (6.6×10^{-4} feet per second) when tested in accordance with modified ASTM D 4716 at 200 kPa (29 psi)..
- 2.1.3.7. Weather resistance: Ensure that the retained strength after 500 hours of weathering is greater than or equal to 60 percent of the initial strength when tested in accordance with ASTM D 4355.
- 2.1.3.8. Alkali resistance: Provide a manufacturer certification that the supplied material is composed of 96% or more polypropylene/polyethylene.
- 2.1.4. Certification: Prior to incorporation in the work, provide the **RCE** with a manufacturer's certification stating that the material being used meets all requirements of this Special Provision for each batch or lot of material. Ensure that the provided certification references the batch number(s) supplied and is attested to by the notarized signature of an officer of the manufacturing company. Also provide the RCE with a copy of the manufacturer's independent test data showing results for all the properties given in this section obtained by the test methods provided. Test data does not have to be batch or lot-specific.
- 2.2. Anchor system requirements:
- 2.2.1. Fasteners: Use hardened steel pin fasteners with a galvanized finish intended for insertion in concrete by a powered fastening tool. Select a diameter and length adequate to anchor the geotextile such that normal paving operations do not dislodge the pins and the base is not damaged by the insertion.
- 2.2.2. Discs: Provide thin, galvanized steel discs ranging from 2.0 to 2.8 inches in diameter with small stamped claws for holding the fabric and distributing the anchoring load.

3. CONSTRUCTION

EXHIBIT 5 - SPECIAL PROVISIONS

- 3.1. Preparation of base: Repair any damaged or defective areas in the base to the satisfaction of the **RCE**. Thoroughly sweep the base immediately prior to fabric placement and ensure that the surface is free of loose debris.
- 3.2. Timing of placement: Place fabric no more than 3 days ahead of paving operations. If concrete is being placed by trucks directly in front of the paver, do not place fabric more than 650 feet ahead of the paver.
- 3.3. Placement: Roll the material onto the base, keeping the fabric tight with no wrinkles or folds. Roll out the sections of the fabric in a sequence that will facilitate good overlapping, prevent folding or tearing by construction traffic, and minimize the potential that the material will be disturbed by the paver. Overlap sections of the fabric a minimum of 6 inches and a maximum of 10 inches. Ensure that no more than three layers overlap at any point. Extend the fabric a minimum of 12 inches beyond the edge of the concrete pavement.
- 3.4. Anchoring: Secure the fabric with fasteners punched through the steel discs into the base. Space the anchors as necessary to securely hold the fabric in position during paving operations. However, maintain a maximum anchor spacing of 6 feet under all circumstances.
- 3.5. Construction traffic: Keep all nonessential traffic off of the fabric. Ensure that operations are staged such that no vehicles make sharp turning motions on the fabric. Remove and replace damaged fabric using required placement overlaps and sufficient anchors.
- 3.6. Moisture: Lightly but completely dampen the fabric ahead of the paving operations to ensure that the fabric does not draw water from the concrete. If the fabric is wetted due to precipitation or other reasons to the point of standing water or that free water appears when the fabric is walked on, allow the fabric to dry to a moist condition before continuing paving operations.

(68) DIVISION 200: GROUND MODIFICATION – COMPACTION GROUTING COLUMNS

August 1, 2005

2.0 GENERAL

2.1 Scope:

The work under this Section consists of furnishing all supervision, labor, material, equipment, and related services necessary to perform ground improvement by the compaction grout technique as indicated on the Contract Drawings and specified herein.

For this project, the purpose of the compaction grouting is to reinforce the loose sand layers below embankments. The compaction grouting will serve to reinforce loose sand in the event of liquefaction during an earthquake.

The work includes the delivery and placement of all concrete/grout material necessary for compaction grouting construction.

2.2 Compaction Grout Column Construction

The work is to be accomplished using specifically-designed equipment for compaction grouting. The drill is to be advanced to the specified compaction grouting depth.

Concrete/grout shall then be injected through the drill pipe as the pipe is being withdrawn, in such a way as to exert a positive lateral pressure on the soil surrounding the concrete/grout filled grout hole.

2.3 Methods and Contractor Qualifications:

The Specialty Contractor performing the compaction grouting installation shall be one who can provide a minimum 3-year experience record documenting 5 recent, successful projects completed with these general site conditions and improvement criteria. References asserting this documentation shall be submitted with the bid.

A detailed description of the proposed construction method (including equipment and personnel) and the qualifications of the proposed Specialty Subcontractor shall be submitted with the bid.

2.4 References:

American Society for Testing and Materials (ASTM) Standards.

American Concrete Institute (ACI) Standards.

Prior to commencing work, the Contractor shall examine the site, drawings, records or existing utilities and other existing subsurface structures, and soil boring logs made available by the Engineer to help determine compaction grouting installation conditions.

Any subsurface data provided by the Department are provided solely as general information for convenience of Contractor. It is expressly understood that the Department, Engineer, or the Engineer's consultants will not be responsible for interpretations or conclusions drawn there from by the Contractor. The Department and Engineer expressly encourage the Contractor to perform soil test borings or other subsurface explorations to determine whether the Contractor's proposed ground modification method is capable of installing the specified compaction grout columns. Additional test borings and other exploratory operations may be made by the Contractor at no additional cost to the Department.

2.5 Submittals:

The following data shall be submitted for the approval of the Engineer prior to beginning of work.

- a. A detailed written procedure to be followed in installing the compaction grout columns and confirming that the specified work requirements have been achieved. The written procedure shall include a detailed description of the specialized equipment to be used.
- b. Proposed compaction grout design mix and descriptions of materials to be used. These shall be in sufficient detail to indicate their compliance with the specifications and either 1.) Laboratory tests of trial mixes made with the proposed mix or 2.) Laboratory tests of the proposed mix used on previous projects.
- c. The Contractor shall be responsible for providing all lines and grades for compaction grouting, including locations of all utilities and surveying markers.
- d. The Contractor shall be responsible for all health and safety requirements including those associated with the handling and disposal of contaminated

EXHIBIT 5 - SPECIAL PROVISIONS

materials. The Contractor shall be responsible for providing written procedures including a Health and Safety Plan.

2.6 **Site Preparation:**

The Contractor shall ensure a firm base on which heavy equipment can be operated safely under its own power.

The Contractor shall accurately locate all compaction grout columns in accordance with approved drawings. Compaction grouting shall be adjusted, as approved by the Engineer, to avoid utilities, foundations, and all other underground construction.

The Contractor shall provide access and maintenance thereof, for the compaction grouting equipment, work force and delivery of materials to the work site.

3.0 PRODUCTS

3.1 **Materials:**

2.1.1 Portland Cement: Portland Cement shall conform to current ASTM standards, designation C 150. The use of cement replacement materials will be permitted subject to the approval of the Engineer and provided that they can be shown to have beneficial effects on concrete impermeability, heat generation during setting and general durability. The mix proportions of use shall be approved. For onsite batching, all cement and cement replacement materials shall be stored in separate containers according to type in waterproof stores or silos.

2.1.2 Mineral Admixture: Mineral admixture, if used, shall be flyash or natural pozzolan which possesses the property of combining with the lime liberated during the process of hydration of Portland Cement to form compounds containing cementitious properties. The material shall conform to ASTM C 618, Class C or Class F.

2.1.3 Fluidifier: Fluidifier shall be a compound possessing characteristics which will increase the fluidity of the mixture, act as water reducing agent and retardant.

2.1.4 Water: Water shall be potable, fresh, clean and free of sewage, oil, acid, alkali, salts or organic matter.

2.1.5 Fine Aggregate: Sand shall meet the requirements of current ASTM standards, designation C 33.

2.2 **Grout Mixes:**

The concrete/grout mix shall consist of Portland cement, sand, and water, and may also contain a mineral admixture and approved fluidifier. The components shall be proportioned and mixed to produce a concrete capable of maintaining the solids in suspension, which may be pumped without difficulty. These materials shall be proportioned to produce a hardened concrete/grout which will achieve the design strength within 28 days. The design 28-day concrete strength for this project shall be 2500 psi.

All materials shall be accurately measured by volume or weight as they are fed to the mixer. Time of mixing shall be not less than one minute at the site. If agitated continuously, the concrete/grout may be held in the mixer or agitator for a period not exceeding two and one half hours at concrete temperatures below 70 degrees F and for

EXHIBIT 5 - SPECIAL PROVISIONS

a period not exceeding two hours at higher temperatures, not exceeding 100 degrees F. Concrete/grout shall not be placed when its temperature exceeds 100 degrees F.

Protect concrete/grout from physical damage or reduced strength which could be caused by frost, freezing actions or low temperatures or from damage during high temperatures in accordance with ACI 305/306.

The concrete/grout mix shall be tested by making a minimum of six 2-inch cubes for each day during which compaction grouting is performed. A set of six cubes shall consist of two cubes to be tested at seven days, and two cubes to be tested at 28 days and two cubes held in reserve. Test cubes shall be cured and tested in accordance with ASTM C 109. Test the flow of each batch of concrete mix.

2.3 Concrete/Grout Testing:

- 2.3.1. Sampling: Concrete/grout for the columns shall be sampled in accordance with ACI standards.
- 2.3.2. Workability: The workability of concrete/grout shall be determined by the slump test as described in ACI standards or by an alternative approved method.
- 2.3.3. Cube Tests: For each mix design of concrete, six cubes shall be made from a single batch when required for 65 cy of concrete/grout or part thereof in each day's work. Testing shall be carried out by an independent and approved laboratory. Two cubes shall be tested at an age of 7 days, two at 28 days, and two cubes shall be held in reserve for further testing, if required. Alternatively, cubes may be tested in accordance with an approved accelerated testing regime. The Contractor shall submit certified copies of the results of all tests to the Engineer.
- 2.3.4. Standard of Acceptance: The standard of acceptance of the concrete mix cubes shall be in accordance with ACI standards or as otherwise approved.
- 2.3.5. Record of Tests: The contractor shall keep a detailed record of the results of all tests on concrete/grout and concrete materials. Each test shall be clearly identified with the columns to which it relates.

2.4 Batching Concrete/Grout:

- 2.4.1. General: Facilities shall be provided for the Engineer to inspect the concrete/grout mixing plant or plants when requested. Unless otherwise specified the requirements in Clauses 2.5.2, 2.5.3, 2.5.4 shall be met.
- 2.4.2. Accuracy of Weighing and Measuring Equipment: The weighing and water-dispensing mechanisms shall be maintained at all times to within the limits of accuracy described in ACI standards.
- 2.4.3. Tolerance in Weights: The weights of the quantities of each size of aggregate and of cement shall be within 2% of the respective weights per batch after due allowance has been made for the presence of free water in the aggregates, which shall be determined by the Contractor by an approved method.
- 2.4.4. Moisture Content of Aggregates: The moisture content of aggregates shall be measured immediately before mixing and as frequently thereafter as is necessary to maintain consistency of mix.

2.5 Mixing Concrete/Grout

- 2.5.1 Type of Mixer: The mixer shall be of the batch type, specifically designed for concrete/grout mixing.
- 2.5.2 Tolerance of Mixer Blades: The mixing blades of pan mixers shall be maintained within the tolerances specified by the manufacturers of the mixers, and the blades shall be replaced when it is no longer possible to maintain the tolerances by adjustment.
- 2.5.3 Cleaning of Mixers: Mixers which have been out of use for more than 30 minutes shall be thoroughly cleaned between the mixing of different types of cement.
- 2.5.4 Minimum Temperature: The temperature of fresh concrete/grout shall not be allowed to fall below 37° F. No frozen material or materials containing ice shall be used. Newly cast columns are to be covered to protect them against freezing unless the final cut off level is at least 0.8 ft. below the final head level as cast. Where a column is cast in frozen ground, appropriate precautions shall be taken to protect any section of the column in contact with the frozen soil where this occurs below the cut off level.

2.6 Transporting Concrete/Grout

- 2.6.1. Method of Transporting: The method of transporting concrete/grout shall be submitted for approval. Concrete/grout shall be transported in uncontaminated watertight containers in such a manner that loss of material and segregation are prevented.
- 2.6.2. Pumping Concrete/Grout: Pumped concrete/grout complying with this Specification may be used. The methods employed in its use shall be subject to approval.

2.7 Ready-mixed Concrete/Grout

- 2.7.1. Conditions of Use: Subject to approval, the Contractor may use ready-mixed concrete/grout in accordance with ACI standards. Approval shall be obtained for each proposed use of ready-mixed concrete/grout in different sections of the Works and for each different mix, which shall comply with this Specification.
- 2.7.2. Mixing Plant: Unless otherwise agreed by the Engineer, truck mixer units and their mixing and discharge performance shall comply with the requirements of ACI standards.

3.0 EXECUTION

3.1 General

The Compaction grout column technology employs a drill stem for both penetration and maintaining borehole stability. The concrete/grout is pumped into the column from the base of the drill stem. All materials and work shall be in accordance with Sections 1, 2 and 3 of this Specification.

3.2 Layout

The procedure for layout of columns and checking their positions shall be approved by the Engineer. The actual compaction grout columns shall be installed within 3 inches of

EXHIBIT 5 - SPECIAL PROVISIONS

the design location shown on the Drawings, approved shop drawings or as otherwise directed by the Engineer.

3.3 Diameter of Columns

The diameter of a column shall be not less than 24-in.

3.4 Equipment

The contractor shall use a drill rig capable of penetrating all necessary soil layers or obstructions.

3.5 Penetration

3.5.1. Penetration Near Recently Cast Columns: Columns shall not be advanced so close to other columns which have recently been cast and which contain workable or unset concrete/grout that a flow of concrete could be induced from or damage caused to any of the columns. A minimum distance of 8 ft (center-to-center) shall be kept between columns less than 24-hours old and on-going column installations.

3.5.2. Removal of Drill Pipe from the Ground: Drill Pipe shall not be extracted from the ground during the penetration or construction of a column in such a way that an open unsupported void or inflow of water into the column section would result.

3.5.3. Depth of Columns: Any failure of a column to reach the required depth, as given in the Specification or shown on the Drawings, shall be reported to the Engineer without delay and a full statement of the reasons given.

3.6 Placing of Concrete/Grout

3.6.1. Mix Design and Workability: Where not otherwise stated in this Section, the concrete shall comply with Section 2 of this Specification. The design and workability of concrete to be used in the formation of a column shall produce a mix which is suitable for pumping. It shall have a target slump of 4 to 6 inches unless otherwise approved and a minimum cement content of 580 lbs/yd³. The fine aggregate shall be in accordance with ACI standards. This mix shall be designed so that segregation does not occur during the placing process, and bleeding of the mix shall be minimized.

3.6.2. Equipment for Supply of Concrete/Grout to Columns: Concrete/Grout shall be supplied to the column through suitable tubing and hoses.

3.6.3. Commencement of Concrete/Grout Supply to Each Column: The technique and equipment used to initiate and maintain the concrete flow shall be such that a column of the full specified cross-section is obtained from the maximum depth to the final cut off level.

3.6.4. Rate of Supply of Concrete/Grout: The concrete/grout shall be supplied to the column at a sufficient rate during drill pipe withdrawal to ensure that a continuous monolithic shaft of the full specified cross-section is formed, free from debris or any segregated concrete/grout. The rate of withdrawal of the drill pipe and pressures of concrete/grout shall be measured and recorded throughout the

EXHIBIT 5 - SPECIAL PROVISIONS

phase of vibrator withdrawal for each column. The Contractor shall submit proposals for his method of monitoring construction for approval prior to the commencement of the Works.

- 3.6.5. Completion of Columns: If the concrete/grout placing in any column cannot be completed in the normal manner, then the column shall be repenetrated before concrete/grout has hardened and shall be completely replaced.
- 3.6.6. Casting Level of Column Head: Concrete shall be cast to the commencing surface level or slightly above unless otherwise specified.
- 3.6.7. Disposal of Contaminated Material: The Contractor is responsible for disposal of all excavated soil, excess water, and spoil generated during installation of the compaction grouting installation at no extra cost. Manifests necessary for waste disposal shall be executed by the Engineer.

3.7 Cutting of Column Heads

When cutting off and trimming columns to the specified cut off level, the Contractor shall take care to avoid shattering or otherwise damaging the rest of the column. Any latence, or contaminated, cracked or defective concrete/grout shall be cut away and the column made good in an approved manner to provide a full and sound section up to the cut off level.

3.8 Documentation:

Any proposed change in the approved construction program, necessitated by a change in the subsurface conditions, shall be submitted in writing to the Engineer for approval.

A daily log shall be submitted to the Engineer by the Contractor to include hole number, start/finish time of treatment, depth of treatment, diameter of drill hole, description of soil penetrated, and volume of grout//concrete placed at depth in no more than 2-ft increments.

4.0 CONSTRUCTION

The compaction grout columns shall be constructed prior to bridge foundations. Positive site drainage shall be established prior to construction of compaction grouting. Contractor shall control all spoils generated during compaction grouting and prevent spoils from flowing offsite. Spoils generated by compaction grouting shall be disposed of properly and removed from the site by the Contractor. No additional compensation shall be made for handling spoil.

Compaction grouting columns shall be constructed to the lines and elevation shown on the plans, and in accordance with the Special Provisions.

Compaction grout columns shall extend from the existing ground surface to the elevations outlined in the plans. No payment will be made for compaction grout columns installed within areas that are later excavated. The contractor shall be responsible to construct compaction grout columns to the depths required, and shall use the methods necessary to penetrate to the required depth, including but not limited to drilling through stiff and dense layers that may be present, as well as obstructions from existing construction.

The compaction grout columns shall be installed to the minimum required Area Replacement Ratio. The required minimum area replacement ratio (A_r) achieved at any

EXHIBIT 5 - SPECIAL PROVISIONS

depth by the compaction grouting shall be that which is equivalent to the diameter of the grout columns at the center-to-center (c-c) spacing shown in the plans and on a triangular pattern. The area replacement ratio shall be defined by the following relationships:

$$A_r = \frac{\text{Column Area} \times 100\%}{\text{Tributary Area}}$$

Where: Column Area = Area of circle based on column diameter as defined below.
Tributary Area = $0.866 (\text{Column Spacing})^2$ for triangular spacing.

Acceptance of the constructed column will be based on the theoretical column diameter determined from the volume of concrete/grout installed.

The Contractor shall, at all times, protect structures, underground utilities and other construction from damage caused by grouting operations. Damaged material shall be replaced or repaired to the satisfaction of the Engineer at no additional cost to the Department.

5.0 METHOD OF MEASUREMENT

The bid item for compaction grouting shall include the delivery and placement of all concrete material necessary for compaction grout column construction. It shall also include disposal of all spoil (surface water, soil, etc.) in a manner acceptable to the Department of Health and Environmental Control and to the Engineer.

6.0 BASIS OF PAYMENT

The quantity of ground modification measured for payments shall be the actual length of the installed compaction grout columns acceptable to the Engineer. No payment will be made for ground modification beyond the limits required by the Contract Documents, unless such increases in the specified area are directed in writing by the Engineer.

The accepted quantity, measured as above, will be paid for at the contract unit price per linear foot for compaction grout columns constructed at the diameter specified in the plans, which price and payment shall be full compensation for furnishing, hauling, treating, compacting of materials, removal of spoils and for all labor, equipment, tools, maintenance, and incidentals necessary to complete this item of work.

Payment will be made under:

Item No.	Pay Item	Pay Unit
8990353	Ground modification – Compaction Grouting Columns	Linear ft

EXHIBIT 5 - SPECIAL PROVISIONS

(69) DIVISION 200: GEOTEXTILES FOR SEPARATION AND STABILIZATION

December 23, 2009

1.0 DESCRIPTION

This work is furnishing and installing geotextiles.

2.0 MATERIALS

A geotextile is defined as any permeable polymeric textile used with foundation, soil, rock, earth, or any other geotechnical engineering related material, as an integral part of a civil engineering project, structure, or system. Use geotextiles and thread used in joining geotextiles manufactured from fibers consisting of long-chain polymers, composed of at least 95 percent by weight of polyolefins or polyesters. Use geotextiles with fibers formed into a stable network such that the fibers or yarns retain their dimensional stability relative to each other, including selvages (edges) during shipping, handling, placement, and in service. Use geotextile free from defects or tears.

- A. **Minimum Average Roll Values.** All property values, with the exception of Apparent Opening Size (AOS), represent Minimum Average Roll Values (MARV) in the weakest principal direction. Provide geotextiles whose average test results from any roll sampled in a lot for conformance or quality assurance testing meets or exceeds minimum values provided in this Section.
- B. **Apparent Opening Size.** Values for Apparent Opening Size (AOS) represent maximum average roll values. Acceptance will be based on ASTM D 4759.
- C. **Separation Geotextile.** Use separation geotextile for unsaturated firm subgrade conditions.
- D. **Stabilization Geotextile.** Use stabilization geotextile for soft, wet, saturated subgrade conditions.

Furnish geotextiles meeting the strength property requirements of Table 1 and the AOS, permittivity, and ultraviolet stability requirements of Table 2 for separation geotextile, Table 3 for stabilization geotextile. The geotextile properties required for each class of survivability are dependent upon geotextile type, i.e. woven or nonwoven. When sewn seams are used, the strength of the sewn seams must be equal to or greater than 90 percent of the specified grab tensile strength.

TABLE 1 - GEOTEXTILE STRENGTH PROPERTY REQUIREMENTS

			GEOTEXTILE SURVIVABILITY ¹			
			Moderate Survivability (CBR ≥ 3; c _u ≥ 1,800 psf)		High Survivability (CBR < 3; c _u < 1,800 psf)	
PROPERTY	TEST METHODS	UNITS	Woven	Nonwoven	Woven	Nonwoven
Grab Elongation	ASTM D 4632	%	< 50	≥ 50	< 50	≥ 50
Grab Strength	ASTM D 4632	lbs.	250	160	315	200
Sewn Seam Strength ²	ASTM D 4632	lbs.	225	145	285	180
Tear Strength	ASTM D 4533	lbs.	90	55	110	80
Puncture Strength	ASTM D 4833	lbs.	90	55	110	80
Apparent Opening Size	ASTM D 4751	Sieve Size	Required property values for AOS, permittivity, and UV stability are based on the geotextile applications. Refer to Table 2 for separation geotextile, Table 3 for stabilization geotextile.			
Permittivity	ASTM D 4491	sec. ⁻¹				
Ultraviolet Stability (retained strength)	ASTM D 4355	%				

Notes:

- 1. All numeric values represent Minimum Average Roll Value (MARV) in the weaker principal direction.

EXHIBIT 5 - SPECIAL PROVISIONS

2. When sewn seams are required. Refer to Section 3, Table 4 for overlap requirements.

2.1 Separation Geotextile. Provide geotextile meeting the strength requirements from Table 1 for the level of survivability specified on the plans or in the special provisions. Provide geotextile meeting the permittivity, apparent opening size, and ultraviolet stability requirements of Table 2.

TABLE 2 - SEPARATION GEOTEXTILE PROPERTY REQUIREMENTS

	TEST METHODS	UNITS	REQUIREMENTS
Geotextile Survivability	As specified from Table 1		
Permittivity ¹	ASTM D 4491	sec. ⁻¹	≥ 0.02
Apparent Opening Size	ASTM D 4751	Sieve Size (mm)	#30 (≤ 0.60)
Ultraviolet Stability (Retained Strength)	ASTM D 4355	%	≥ 50 after 500 hrs. of exposure

Notes:

1. Minimum value. Permittivity of the geotextile must be greater than that required for the soil. Use greater value as specified on the plans or in the special provisions.

2.2 Stabilization Geotextile. Do not use woven slit film geotextiles (i.e. geotextiles made from yarns of a flat, tape-like character). Provide geotextile meeting the strength requirements for high survivability from Table 1. Provide geotextile meeting the permittivity, apparent opening size, and ultraviolet stability requirements of Table 3.

TABLE 3 - STABILIZATION GEOTEXTILE PROPERTY REQUIREMENTS¹

	TEST METHODS	UNITS	REQUIREMENTS
Geotextile Survivability	High Survivability from Table 1		
Permittivity ²	ASTM D 4491	sec. ⁻¹	≥ 0.10
Apparent Opening Size	ASTM D 4751	Sieve Size (mm)	#40 (≤ 0.43)
Ultraviolet Stability (Retained Strength)	ASTM D 4355	%	≥ 50 after 500 hrs. of exposure

Notes:

1. Do not use woven slit film geotextiles.
2. Minimum value. Permittivity of the geotextile must be greater than that required for the soil. Use greater value as specified on the plans or in the special provisions.

2.3 Source Approval. Submit the following information regarding each geotextile proposed for use:

- Manufacturer's name and current address;
- Full product name/number;
- Geosynthetic material and structure; and
- Proposed geotextile use(s).

Submit a sample to the RCE for evaluation. Product acceptance is determined by comparing the average test results of all specimens within a given sample to the Minimum Average Roll Values (MARV) listed in Table 1.

Install geotextiles only after the material has been tested and accepted. Replace all geotextiles installed prior to acceptance that do not meet specifications at Contractor's expense.

EXHIBIT 5 - SPECIAL PROVISIONS

2.4 Sampling. Cut a sample from the geotextile roll with the minimum dimensions of 4 feet by the full width of the roll beyond the first wrap. After the sample and the required information have been submitted to the RCE, allow 30 calendar days for evaluation.

2.5 Identification, Shipment and Storage. Conform to ASTM D 4873, *Standard Guide for Identification, Storage, and Handling of Geotextiles*. Clearly label each roll of geotextile shipped to the project with the name and address of the manufacturer, full product name/number, quantity, and roll number. Submit a manufacturer's certificate of compliance signed by an authorized manufacturer's official. The certificate must attest that the geotextile meets all the Minimum Average Roll Value (MARV) requirements specified in Table 1 as evaluated under the manufacturer's quality control program.

The RCE will reject materials that are mislabeled or misrepresented. Wrap each roll with a material that protects the geotextile, including ends of the roll, from damage due to shipment, water, sunlight, and contaminants. Maintain the protective wrapping during periods of shipment and storage. Do not damage the geotextile or wrapping when unloading or transferring from one location to another. Do not drag the rolls.

During storage, elevate geotextile rolls off the ground and adequately cover to protect them from the following:

- Site construction damage;
- Precipitation;
- Ultraviolet radiation including sunlight;
- Chemicals that are strong acids or strong bases;
- Flames including welding sparks, temperatures in excess of 140 °F (60 °C); and
- Mud, dirt, dust, debris and any other environmental condition that may damage the physical property values of the geotextile.

3.0 CONSTRUCTION REQUIREMENTS

3.1 General. Prepare the surface on which the geotextile is to be placed so that no damage occurs to the geotextile. Do not drive construction equipment on the geotextile. Dispose of material with defects, rips, holes, flaws, deterioration, or other damage. Do not use defective material in the work.

If sewn seams are used for seaming the geotextile, use thread that consists of high strength polypropylene or polyester. Do not use nylon thread. Use thread that is of contrasting color to that of the geotextile itself.

For seams that are sewn in the field, provide at least a 10-foot length of sewn seam for sampling by the RCE before the geotextile is installed. For seams that are sewn in the factory, provide samples as directed and witnessed by the RCE at random from any roll of geotextile that is used on the project.

For seams that are field sewn, use the same equipment and procedures for both the sampling and production seams. If seams are to be sewn in both the machine and cross-machine direction, provide samples of seams from both directions.

Submit the seam assembly description along with the sample of the seam. Include in the description the seam type, stitch type, sewing thread, and stitch density.

3.2 Separation/Stabilization Geotextile. Prepare the installation site by clearing, grubbing, and excavating or filling the area to the design grade. This includes removal of topsoil or vegetation. The RCE will identify soft spots and unsuitable areas during site preparation. Excavate these areas and backfill with approved granular material and compact as specified. Grade the area to be covered by the geotextile to a smooth, uniform condition, free from ruts, potholes, and protruding objects such as rocks or sticks.

EXHIBIT 5 - SPECIAL PROVISIONS

Spread the geotextile immediately ahead of the covering operation. Lay the geotextile smooth without wrinkles or folds on the prepared subgrade in the direction of construction traffic. Remove wrinkles and folds by pulling the geotextile taut as required. Use soil piles or the manufacturer's recommended method (as approved by the RCE) to hold the geotextile in place until the specified cover material is placed. Overlap, sew or join adjacent geotextile rolls and roll ends as shown on the plans or as directed by the RCE. Overlap in the direction shown on the plans. Overlap in accordance with the requirements of Table 4, or as specified on the plans or in the special provisions.

TABLE 4 - OVERLAP REQUIREMENTS

UNDRAINED SHEAR STRENGTH OF SUBGRADE	MINIMUM OVERLAP
> 2,000 psf	1 foot
500-2,000 psf	3 feet or Sewn
< 500 psf	Sewn
All roll ends	3 feet or Sewn

On curves, cut or fold the geotextile to conform to the curve. Fold or overlap in the direction of construction and hold in place using pins, staples, or piles of fill or rock.

Do not cover the geotextile until inspected for damage by the RCE. Repair or replace all damaged geotextile at Contractor's expense. Make repairs following the manufacturer's recommendation or use a patch of the same material placed over the damaged area, overlapped at least 3 feet from the edge of any part of the damage. Sewing repairs are an acceptable alternative.

Place fill over the geotextile by dumping onto previously placed material and pushing the material into place. Do not operate any construction equipment directly on the geotextile under any circumstances. Place the fill material in uniform layers so that there is the minimum specified lift thickness between the geotextile and equipment tires or tracks at all times. The minimum thickness of the first lift is 8 inches. Do not allow construction equipment to turn on the first lift of material above the geotextile. Do not blade the first lift placed over the geotextile. If the subgrade is very soft with an undrained shear strength less than 500 psf minimize pile heights to less than 3 feet and spread piles as soon as possible after dumping to minimize the potential for localized subgrade failure due to overloading of the subgrade.

Do not use sheepsfoot or studded compaction equipment on the first lift placed over the geotextile. Stop vibrator on compaction equipment if pumping occurs. Do not operate any construction equipment that results in rutting in excess of 3 inches on the first lift. If rutting exceeds 3 inches, decrease the construction equipment size and/or weight or increase the lift thickness. Use only rubber-tired rollers for compaction if any foundation failures occur when placing subsequent lifts. Compact all lifts to the moisture and density requirements for earth embankment specified in the Standard Construction Specifications. Do not blade material down to remove ruts. Fill any ruts or depressions with additional material and compact to the specified density.

4.0 METHOD OF MEASUREMENT

Geotextiles are measured by the square yard as staked by the RCE. Measurement excludes laps, seams, and joints.

5.0 BASIS OF PAYMENT

Payment at the contract unit price is full compensation for all resources necessary to complete the item of work under the contract. Payment for the completed and accepted quantities is made under the following:

<u>Pay Item</u>	<u>Pay Unit</u>
Geotextile, Separation/Stabilization	Square Yard

(70) DIVISION 200: BRIDGE LIFT MATERIALS

Division 200 is expanded as follows.

1.0 DESCRIPTION

The requirements of this specification shall consist of furnishing all necessary submittals and materials for providing bridge lift materials in accordance with the details shown on the plans and the requirements of the Supplemental Specifications. The bridge lift materials shall be installed at locations show on the plans, unless otherwise directed by the Department.

2.0 MATERIALS

The materials provided for under this specification shall be used for bridge lifts. Bridge lift materials shall consist of two general types, first materials that can be placed through water and those materials that are placed over soft exposed subgrades without water being present. The materials placed through water shall consist of either stone or coarse granular materials. The materials placed on soft exposed subgrades may consist of borrow excavation, stone or coarse granular materials.

2.1 Stone Materials: The stone materials shall meet the specification requirements of No. 57 or No. 67 Coarse Aggregate (stone) as described in the current edition of the SCDOT Standard Specifications for Highway Construction. The stone shall consist of durable particles that are comprised of naturally occurring materials including marine limestone or man-made materials. The man-made materials are limited to light weight materials that meet the gradation requirements previously indicated and have a unit weight of at least 65 pounds per cubic foot. The natural materials shall have a dry unit weight of at least 105 pounds per cubic foot. Recycled materials may not be used.

2.2 Granular Materials: The granular materials shall meet the specification requirements for an A-1-a (AASHTO M-145) as indicated in the following table.

Sieve Analysis	Percent Passing
No. 10	50 max.
No. 40	30 max.
No. 200	15 max.
Plasticity Index	6 max.
Organics	1 max.

The granular materials shall consist of durable, naturally occurring particles. The granular materials shall have a dry unit weight of at least 110 pounds per cubic foot. Recycled materials may not be used.

2.3 Borrow Excavation Materials: Borrow excavation materials used as a bridge lift shall be limited to A-1, A-2 and A-3 materials (AASHTO M-145). The borrow excavation materials shall meet the requirements as described in the current edition of the SCDOT Standard Specifications for Highway Construction.

2.4 Submittals: The contractor is required to submit copies of gradation testing to the Department prior to delivery of the material to the site and at the discretion of the RCE as placement proceeds, if in the opinion of the RCE additional verification of the gradation is required.

3.0 METHOD OF MEASUREMENT

Stone bridge lift materials shall be measured by the ton (TON) when included in the Contract. Granular bridge lift materials shall be measured by the cubic yard (CY) when included in the Contract. The quantity of granular bridge lift material includes the material acceptably excavated and is measured in its

EXHIBIT 5 - SPECIAL PROVISIONS

original position and determined from cross-sections by the method of average-end-areas, complete and accepted. Borrow excavation bridge lift materials shall be measured and included the total borrow material required for the project.

4.0 BASIS OF PAYMENT

Unless otherwise specified, payment for the accepted quantity of material, as specified herein, measured in accordance with this specification, is determined using the contract unit bid price for the applicable pay item. Payment is full compensation for obtaining, hauling and placing the material and all other materials, labor, equipment, tools, supplies and incidentals necessary to satisfactorily complete the work as required in the Plans, Project Specifications and other terms in the Contract.

Where the Contractor is required to furnish the borrow pits for granular bridge lift material, payment for the granular bridge lift material includes the cost of the borrow pit, clearing and grubbing of pits, necessary haul roads, hauling of the borrow material to the designated location on the project and for all other pertinent stipulations stated above.

Payment of borrow excavation bridge lift material shall be included in the quantity of borrow excavation used on the project.

Payments shall be made under:

Item No.	Pay Item	Pay Unit
2052010	Stone Bridge Lift Material	TON
2052020	Granular Bridge Lift Material	CY

(71) DIVISION 200: DEEP SOIL MIXING

September 21, 2011

1.0 Description. This work shall consist of using deep soil mixing (DSM) construction techniques (also known as deep mixing methods, DMM) to improve weak subsurface soils by mixing a binder material with in-situ soil to produce a DSM column composed of a soil-binder mixture that has increased compressive strength and stiffness properties compared to the original in-situ soil properties. A column is defined as the extent that the existing ground is improved by insertion and removal of the mixing tool to the full improvement depth required in the plans. DSM column mixing methods allowed are described in subsection 1.1 and DSM column spacing requirements are described in subsection 1.2. The purpose for constructing DSM columns is to improve weak subsurface soils in order to stabilize and/or improve performance of existing ground prior to constructing bridge foundations, embankments, mechanically stabilized earth (MSE) walls, retaining walls, and other transportation structures or facilities as specified herein and shown on the plans and contract documents. References listed in subsection 1.3 may be used in these special provisions and will be used to evaluate this work.

The work covered by this specification includes furnishing all necessary plant, labor, equipment, geotechnical subsurface investigation, pre-production laboratory testing, test section(s), surcharges/berms constructed at the DSM improved locations (if shown in the plans or required to meet DSM column performance requirements), in-situ testing, sampling/coring, QA/QC testing, reporting, and other work described below. The Contractor shall be familiar with project geotechnical conditions and recognize that geotechnical data is available with geotechnical boring logs, laboratory testing results, and other pertinent information.

EXHIBIT 5 - SPECIAL PROVISIONS

1.1 DSM Mixing Methods: This special provision contains specifications for construction of DSM columns by either the wet or dry mechanical mixing method. The Contractor shall use the DSM mechanical mixing method specified in the plans unless other methods are approved in writing by the Engineer. DSM column mixing method for the wet and dry mixing methods are defined as follows:

1. **Wet Method:** The wet method consist of mixing a binder in slurry form (i.e. cement grout) with existing soils using auger-type equipment (paddles, augers, and other rigid mixing tools), without use of externally directed high pressure jets, to form a DSM column consisting of a homogeneous mixture of cement grout and in-situ soils. The wet mixing method typically produces spoils in the range of 10 to 60 percent of the treated volume. A soil-cement column formed by the wet mixing method is abbreviated herein as DSM-SCC).
2. **Dry Method:** The dry method consists of mixing dry binders (i.e. lime-cement or cement) into the in-situ soils. The dry binder is injected into the soil by using air pressure. The mixing tool blends the binder material with the in-situ soil and water to form a DSM column of a homogeneous mixture of binder materials and in-situ soils. The dry mixing method typically produces spoils less than 10 percent of the treated volume. A DSM column (lime-cement or cement) formed by the dry mixing method is abbreviated herein as DSM-LCC.

1.2 DSM Column Spacing: The DSM columns shall be spaced and arranged as indicated on the plans or as otherwise directed by the Engineer. DSM columns can be constructed by using group column spacing or by using block column spacing as described below:

1. **Group Column Spacing (GCS):** DSM group column spacing (GCS) consists of constructing a single column (no overlap with adjacent DSM columns) with a diameter of 20 to 36 inches or as required in the plans. The DSM columns group spacing is defined in the plans by specifying a pattern (i.e. triangular, grid, etc.) and a center-to-center spacing between DSM columns.
2. **Block Column Spacing (BCS):** DSM block columns spacing (BCS) consists of constructing an improved soil zone with DSM columns overlapping adjacent DSM columns. Since the improved soil zone is continuous, the size of the DSM column is not specified in the plans to accommodate variations in the Contractor's equipment dimensions. As a result of Contractor equipment variations in size, any variations in the dimensions of the zone of ground improvement shown in the plans will require written approval by the Engineer. The center-to-center spacing shall be determined by the Contractor based on the DSM construction equipment in order to provide continuous overlapped DSM columns in accordance with the plans and specifications. Continuous column spacing may be achieved by the use of DSM equipment capable of constructing multiple columns simultaneously. The DSM column overlap distance between adjacent DSM columns shall be a minimum of 20 percent of the DSM column diameter or as approved by the Engineer. The DSM column center-to-center spacing between adjacent columns shall be defined as the DSM column diameter minus the column overlap distance.

1.3 References: The evaluation of this work, including the DSM Installation Plan, test section(s), QC testing, and QA testing will be based on, but not limited to, the following references:

1. Bruce, D.A. (2000). "An Introduction to the Deep Soil Mixing Methods as Used in Geotechnical Applications, Volume I," FHWA-RD-99-138.
2. Bruce, D.A. (2000). "An Introduction to the Deep Soil Mixing Methods as Used in Geotechnical Applications, Volume II: Appendices," FHWA-RD-99-149.
3. Bruce, D.A. (2001). "An Introduction to the Deep Mixing Methods as Used in Geotechnical Applications, Volume III: The Verification and Properties of treated Ground," FHWA-RD-99-167.
4. Elias, V., Welsh, J., Warren, J., Lukas, R., Collin, J.G., and Berg, R.R., (2006). "Ground Improvement Methods," Volumes I and II, FHWA NHI-06-019 and FHWA NHI-06-020, US Dept. of Transportation, Federal Highway Administration.

EXHIBIT 5 - SPECIAL PROVISIONS

5. Filz, G. M., Hodges, D. E., Weatherby, D. E., and Marr, W. A. (2005). "Standardized Definitions and Laboratory Procedures for Soil-Cement Specimens Applicable to the Wet Method of Deep Mixing." *Innovations in Grouting and Soil Improvement*, Reston, Virginia, 13.
6. Filz, G. M. and Stewart, M. E. (2005). "Design of Bridging Layers in Geosynthetic-Reinforced, Column-Supported Embankments." Virginia Transportation Research Council, Charlottesville, VA
7. Jacobson, J. R., Filz, G. M., and Mitchell, J. K. (2003). "Factors Affecting Strength Gain in Lime-Cement Columns and Development of a Laboratory Testing Procedure," Report prepared for the Virginia Transportation Research Council, Virginia Polytechnic Institute and State University, Report No. 57565, FHWA/VTRC 03-CR16.
8. Jacobson, J. R., Filz, G. M., and Mitchell, J. K. (2005). "Factors Affecting Strength of Lime-Cement Columns Based on a Laboratory Study of Three Organic Soils." Deep Mixing'05: International conference on deep mixing best practice and recent advances.
9. Larsson, S. (2005a). "State of Practice Report – Execution, monitoring and quality control," Volume 2, Deep Mixing '05: International Conference on Deep Mixing Best Practice and Recent Advances.
10. Larsson, S. (2005b). "On the use of CPT for quality assessment of lime-cement columns." Deep Mixing '05: International Conference on Deep Mixing Best Practice and Recent Advances.
11. McGinn, A. J. and O'Rourke, T. D. (2003). "Performance of deep mixing methods at Fort Point Channel." Cornell University.

2.0 Materials.

2.1 Wet Method (DSM-SCC):

Cement: Portland cement shall be low alkali Type II conforming to Section 701.2.1 and ASTM C150. Slag cement shall conform to Section 701.2.3 and ASTM C 989. All cement shall be homogeneous in composition and properties, and shall be manufactured using the same methods at one plant by one supplier. Tricalcium aluminate content shall not exceed 7 percent.

Water: Water shall conform to the requirements of Section 701.2.11.

Admixtures: Cement admixtures will not be allowed without written approval by the Engineer. Cement admixtures are ingredients that are used to permit efficient use of materials and proper workability of the binder material being mixed into the in-situ soils. The Contractor is required to submit any proposed admixtures and their intended effect when the binder mix design is submitted for approval by the Engineer.

Cement Grout: The cement grout shall be a stable homogeneous mixture of cement, admixtures (if approved), and water in proportions determined by the results of the test section and approved by the Engineer. The cement grout is mixed with the in-situ soils to form DSM-SCC columns.

Soil-Cement Mixture: The DSM column shall be composed of a stable and uniform soil-cement mixture of cement grout and in-situ soil that meets the project compressive strength and other requirements in the plans and these special provisions. The proposed ratios of concrete grout to in-situ soils and quantities of various components shall be determined by the results of the test section and approved by the Engineer.

2.2 Dry Method (DSM-LCC):

Cement: Portland cement shall be low alkali Type II conforming to Section 701.2.1 and ASTM C150. Slag cement shall conform to Section 701.2.3 and ASTM C 989. All cement shall be homogeneous in composition and properties, and shall be manufactured using the same methods at one plant by one supplier. Tricalcium aluminate content shall not exceed 7 percent.

EXHIBIT 5 - SPECIAL PROVISIONS

Quick Lime: Quick lime shall have at least 99 percent passing the #8 sieve (3.18 mm) and at least 90 percent passing a No. 12 Sieve (2.12 mm), an active CaO content greater than 80% and a floatability of 70.

Premixed Lime-Cement: If a premixed quick lime and cement is to be used, the manufacturer of the mixture must certify that the proportions of lime and cement provided are in accordance with the design requirements developed from the test section and approved by the Engineer.

Admixtures: Cement admixtures will not be allowed without written approval by the Engineer. Cement admixtures are ingredients that are used to permit efficient use of materials and proper workability of the binder material being mixed into the in-situ soils. The Contractor is required to submit any proposed admixtures and their intended effect when the binder mix design is submitted for approval by the Engineer.

Binder: The binder will be a stable homogeneous mixture of cement, lime (if applicable), and admixtures (if approved), in proportions determined by the results of the test section and approved by the Engineer. The binder material is delivered using air pressure and is mixed with the in-situ soils to form DSM-LCC columns.

Soil-Binder Mixture: The DSM column will be composed of a stable and uniform soil-binder mixture that meets the project design requirements and these special provisions. The proposed ratios of binder material to in-situ soils and quantities of various components shall be determined by the results of the test section and approved by the Engineer.

3.0 Submittals. A minimum of 45 calendar days prior to beginning the DSM work, the Contractor shall submit a DSM Construction Plan and Shop Plans/Working Drawings for review and approval by the Engineer. The DSM Construction Plan and Shop Plans/Working Drawings shall be prepared, signed, and sealed by an agent/representative of the DSM Contractor that is a professional engineer licensed in the State of South Carolina. The Contractor shall not commence DSM installation without the approval of all submittals by the Engineer. Approval by the Engineer will not relieve the Contractor of its responsibilities to provide materials and equipment necessary to install DSM columns in accordance with the plans and specifications. If, at any time, the Engineer considers that the Contractor's installation operation does not produce a satisfactory DSM column, the Contractor shall alter its method and/or equipment as necessary to comply with the plans and specifications at no additional cost to the Department.

The Contractor shall submit 8 sets of the DSM Construction Plan and 8 sets of Shop Plans/Working Drawings to the Preconstruction Support Engineer (PSE) for review in accordance with the requirements provided herein. Send DSM Construction Plan and Shop Plans/Working Drawings for projects designed for the Department by a design consultant directly to the consultant. For DSM Construction Plan and Shop Plans/Working Drawings sent to the PSE, send a copy of the transmittal letter to the BCE, the OMR, and the RCE. For Shop Plans sent directly to a design consultant, send a copy of the transmittal letter to the PSE, the BCE, the OMR, and the RCE. Obtain the necessary mailing information at the Preconstruction Conference.

3.1 DSM Construction Plan: The DSM Construction Plan shall document and provide, as a minimum, the following information:

1. *Qualifications:* Evidence of six years of accumulated experience over a period of 10 years and competence to construct the required DSM columns by the mixing method (i.e. wet or dry) required for the project shall be submitted. As a minimum, the Contractor shall submit a detailed description of three DSM projects completed using the required mixing method within the previous six years that demonstrate the Contractor's experience and competence. Jet grouting or penetration grouting projects will not be acceptable as representative of DSM construction techniques. Each DSM project submitted as proof of experience and competence shall have a minimum total treatment volume of not less than 20 percent of the DSM treatment volume for this

EXHIBIT 5 - SPECIAL PROVISIONS

project or 30,000 cubic yards of DSM treatment volume, whichever is greater, in high plasticity clay, sand, and silt. At least two of the submitted DSM projects using the required mixing method shall have average treatment depths greater than 60 feet. Each DSM project submitted shall have the following information:

- a. Project name, location, and completion date.
- b. Current contact information (address, phone number, and email) of project owner, designer, geotechnical consultant, and contract manager.
- c. Surface and subsurface conditions, and strength (average, ranges, and means used to determine strength) of DSM columns installed.
- d. Minimum, maximum, and average rates of DSM installation.
- e. Project cost and duration of DSM installation.
- f. Average depths and ranges of depths of DSM columns installed. Provide total linear footage and volume (cubic yards) of DSM columns installed.
- g. Percent of project total based on QA/QC testing that met the project Acceptance Criteria and percent of project total based on QA/QC testing that required remediation techniques after initial DSM installation.

The Contractor shall also submit a list of completed ground improvement projects where they performed DSM column construction techniques over the past six years that includes items "a" and "e" listed above, type of DSM mixing, and DSM quantity constructed (similar to item "f" above).

The Contractor's proposed DSM superintendent shall have a minimum of three years of accumulated experience with DSM construction equipment and construction management within the past six years. The DSM superintendent shall have been employed by the Contractor for the most recent three years. The proposed DSM superintendent shall have been superintendent for the Contractor on at least one of the three DSM projects submitted by the Contractor as evidence of their experience. Experience and training records shall be submitted for proposed DSM superintendent and operators of construction equipment. Any changes in DSM construction personnel shall require submittal of qualifications for approval.

The Independent Testing Laboratory shall have at least 5-years' experience as a materials testing laboratory, including the performance of testing comparable to that required herein. The person in charge of the testing work for the Independent Testing Firm shall be a Professional Civil Engineer, registered in the State of South Carolina. The Independent Testing Laboratory's supervisor and each field representative who will take samples in the field shall have at least 5-years' experience in taking concrete samples in the field and performing compressive strength tests in accordance with AASHTO requirements, and be accredited as required by SCDOT to obtain and form concrete test cylinders. The persons who will perform laboratory testing shall have at least 2-years' experience in performing the soil tests required herein.

2. *Protection of Utilities:* Location of all subsurface utilities in the area and the plan to protect them in place if the utilities are not being relocated out of the affected area.
3. *Construction Schedule:* A construction schedule for the DSM work identifying start dates and durations for all portions of the work, including equipment mobilization, equipment setup, test section(s) construction, production DSM construction at each location, and QC testing.
4. *DSM Mixing Method:* Provide the type of mixing method (Wet or Dry) that will be used in accordance with the plan documents to construct the DSM columns in accordance with the plans and these specifications.
5. *Equipment and Procedures:* A detailed description of the equipment (include catalog cut sheets of equipment dimensions) and procedures to be used during all facets of the project including, but not limited to the conduct of the following:
 - a. Test section(s)

EXHIBIT 5 - SPECIAL PROVISIONS

- b. Site preparation
 - c. Stage construction of DSM test section(s) and production DSM (if required)
 - d. Locating the DSM columns in the field
 - e. DSM spoil containment, handling, and disposal
 - f. Confirming method to check that the DSM are installed plumb
 - g. Quality control program
 - h. Monitoring quality control parameters
 - i. Sample collecting for laboratory confirmation testing
6. *DSM Test Section Subsurface Information and Location*: Submit the probe testing results used to pre-approve the location of the test section(s). Provide a minimum of two probe test at each test section in accordance with Section 8.2 for review and approval by the Engineer of the proposed location of the test section(s). Pre-approval of the test section location(s) shall be required before commencing Pre-production field and laboratory testing (Section 4.0). Probe testing shall be conducted to the production DSM depths plus 10 feet that the test section represents. Indicate on a plan drawing the location of the test section(s), dimensions and layout of the test section(s), number of DSM columns (include designation of each DSM column), and location of probe testing performed (Section 8.2). This information should be included in this submittal even if submitted previously during pre-approval of DSM test section location(s).
7. *Pre-Production DSM Binder Mix Design Report*: Final report of pre-production laboratory and field testing used to develop proposed wet or dry binder mix design for the construction of the test section(s). The pre-production laboratory and field testing shall conform to Section 4.0 of this special provision.
8. *Cement and Cement Grout Mix Design (Wet Mixing Method, DSM-SCC)*: Proposed cement and cement grout mix design when DSM columns are constructed using the wet mixing method (DSM-SCC). The design shall include the following:
- a. Cement type and Cement manufacturer's certificate of compliance.
 - b. Cement grout water-cement ratio, by weight. Include details to fully describe and illustrate the methods for grout proportioning to achieve the design mix.
 - c. Cement Factor (also known as Residual Cement Factor) which is the amount of cement, dry weight in pounds, that remains in the ground after mixing, per cubic yard of in-situ soil-cement.

These mix design parameters will be reviewed based on the pre-production field and laboratory testing results developed in accordance with Section 4.0. The acceptance of the proposed grout mix/soil/cement mix design shall be contingent on the test section(s) results meeting the acceptance criteria of Section 11.0. The Contractor may propose to expand the size of the test section to demonstrate that somewhat different grout water/cement ratio and/or cement factor is workable in achieving the required soil-cement strength under actual in-situ conditions. Provide documentation of calibration of the mixing plant.

9. *Binder Mix Design (Dry Mixing Method, DSM-LCC)*: Proposed binder mix design(s) when DSM columns are constructed using the dry mixing method (DSM-LCC). Binder mix design shall include all materials, quantities, and dosages required to achieve the Acceptance Criteria (Section 11.0). The design shall include the following:
- a. Cement type and Cement manufacturer's certificate of compliance.
 - b. Quick lime (if used) manufacturer's certificate of compliance.
 - c. Pre-mixed lime-cement (if used) manufacturer's certificate of compliance
 - d. Binder mix dosage of each material in the binder mix per volume.
 - e. Proportion of binder material to soil in the soil-binder mixture.

These mix design parameters will be reviewed based on the pre-production field and laboratory testing results developed in accordance with section 4.0. The acceptance of the proposed binder

EXHIBIT 5 - SPECIAL PROVISIONS

and soil/binder mix design shall be contingent on the test section(s) results meeting the acceptance criteria of section 11.0. The Contractor may propose to expand the size of the test section to demonstrate that somewhat different binder mix design is workable in achieving the required soil-binder strength under actual in-situ conditions. Provide documentation of calibration of the mixing plant.

10. *Independent Laboratory Testing*: Identification of all independent AASHTO certified materials laboratory testing facilities that will be used on the project and the type laboratory testing that will be conducted at each laboratory. All laboratory testing shall be performed at a materials laboratory with current AASHTO certification for the type of test being conducted. A single independent AASHTO certified materials testing laboratory shall be used to conduct all of the compressive strength testing that will be performed on the project.
11. *Calibrations*: Calibration tests for all metering equipment, including mixing systems, delivery systems, alignment systems, mixing tool rotational and vertical speed, injection pressure, rotation penetration/extraction rates, etc. that are applicable to the mixing method being used on the project.
12. *Surcharges/Berms*: Details of any surcharges/berms being constructed as indicated in the plans or required to obtain DSM column performance in accordance with plans and specifications. Provide a description of materials used (soil type, atterberg limits, moisture content, etc.), location, and removal schedule (if required). Surcharges that are required to obtain DSM column performance and are not shown in the plans shall be constructed after being approved by the Engineer and at no additional cost to the Department.
13. *Runoff and Spoil Containment (Wet Mixing Method Only)*: Details of all run-off and spoil containment structures will be required when DSM columns are constructed using the wet mixing method (DSM-SCC). These structures will be used to prevent the migration of either cement grout or soil-cement return spoils, disturbed in-situ soils, or other soil material beyond the immediate limits of the soil-cement mixing operation. Also provide description of processes and procedures to be used to collect and retain the soil-cement return and other spoil materials in such manner to allow the spoils to solidify for the necessary time to become a hardened material resembling a hard, dry cohesive material. The resulting hardened spoils shall be disposed of off-site, at no additional cost to the Department.
14. *Daily Production Control Report and Installation Log*: Provide a sample report and installation log in paper and electronic format that will be used to record the construction of all production DSM columns for the required mixing method. The Daily Production Control Report/Log shall contain at least the following information:
 - a. Project Name.
 - b. DSM column number and reference drawing number.
 - c. Date.
 - d. Name of DSM Superintendent and equipment operator.
 - e. Start/Finish time of DSM column installation.
 - f. Machine/Rig Number.
 - g. Type of mixing tool and indicate if single or multiple columns formed per stroke.
 - h. DSM column(s) diameter/size.
 - i. DSM column(s) total length (include top and bottom elevations).
 - j. DSM column center-to-center spacing from adjacent DSM column.
 - k. Verticality of mixing tool in two orthogonal planes for each DSM column.
 - l. Binder mix design designation used.
 - m. A description of obstructions, interruptions, DSM column construction out of tolerance or other difficulties encountered during installation of DSM column and how they were resolved.

EXHIBIT 5 - SPECIAL PROVISIONS

- n. *Material Certifications*: Supplier's certifications of binder materials quality and other additives, if used.

Wet Mixing Method (DSM-SCC) reports shall include the following:

- o. Final current draw for the drilling equipment at the bottom 2 feet of penetration or final hydraulic pressure, if hydraulic motors are used to turn the mixing tools.
- p. Grout injection pressure and volume
- q. Estimate of spoil volume
- r. Target and actual cement factors and grout specific gravity measurements per DSM-SCC column.
- s. Date, time, plan location, and elevation and other details of all soil-cement wet grab samples and any other samples taken during work shift.
- t. The following information shall be logged using automated computer technology for each DSM-SCC installed at intervals no greater than 4 feet and presented in table and graphical forms:
 - Elevation in feet.
 - Mixing tool rotation penetration and withdrawal speed in revolutions per minute vs. depth in feet.
 - Mixing tool rotation penetration and withdrawal rates in feet per minute vs. depth in feet.
 - Mixing tool withdrawal rate in mm/revolution vs. depth in feet.
 - Grout injection rate in gallons per minute vs. depth in feet.
 - Average quantity of grout injected in gallons per foot injected per vertical foot of DSM-SCC vs. depth in feet.

Dry Mixing Method (DSM-LCC) reports shall include the following:

- o. Installation air pressure at tip and top of the lime-cement column.
- p. Target and actual binder dosage mixed per DSM-LCC column.
- q. The following information shall be logged using automated computer technology for each DSM-LCC installed at intervals no greater than 4 feet and presented in table and graphical forms:
 - Elevation in feet.
 - Mixing tool rotation penetration and withdrawal speed in revolutions per minute vs. depth in feet.
 - Mixing tool rotation penetration and withdrawal rates in feet per minute vs. depth in feet.
 - Mixing tool withdrawal rate in mm/revolution vs. depth in feet.
 - Quantity of binder reagent (i.e. quick lime, cement, and admixtures) injected in kg/ft
 - Average binder reagent injected in kg per foot injected per vertical foot of DSM-LCC vs. depth in feet.

3.2 Shop Plan/Working Drawing: The Shop Plan/Working Drawing shall contain the location and extent of all production DSM columns that will be constructed as indicated in the plans. Indicate DSM column spacing and overlap dimensions, including overall dimensions of ground improvement area. Provide the production DSM column numbering system/identification for each location where DSM columns will be constructed. Provide the sequence of DSM column construction that will be used to minimize the effects of ground movements on adjacent existing structures (i.e. MSE walls). The Shop Plan/Working Drawing shall be prepared, signed, and sealed by a professional engineer licensed in the State of South Carolina.

4.0 Pre-Production Field and Laboratory Testing. A pre-production field and laboratory testing program will be required to develop the proposed DSM wet or dry binder mix design prior to the construction of the test section(s). The field testing program consists of conducting a geotechnical subsurface investigation in accordance with subsection 4.1 of this special provision. Soil samples obtained from the geotechnical subsurface investigation shall be used to develop and conduct the

EXHIBIT 5 - SPECIAL PROVISIONS

pre-production laboratory testing. The pre-production laboratory testing will be required to establish a "base line" of the degree of ground improvement that is possible under optimal construction circumstances for various DSM binder mixes for each distinct soil type that will be encountered during the conduct of the DSM ground improvement. It is recognized that the pre-production laboratory testing will be used as a general indicator of ground improvement that may be obtained in-situ because of substantial differences inherent between laboratory and in-situ mixing conditions. The Contractor shall take appropriate account of these differences, based on published documents and the Contractor's experience, to develop a DSM binder mix design that can be used for constructing the test section(s) based on the results of the pre-production laboratory testing. A pre-production laboratory testing program shall be required for each test section. A DSM binder mix design shall be developed for each major soil type encountered throughout the depth of ground improvement. As a minimum, two binder mix designs for two types of soil shall be required per test section. The minimum pre-production laboratory testing requirements for wet and dry mixing methods are provided in subsections 4.2 and 4.3 of this special provision, respectively.

The Contractor shall submit the geotechnical subsurface investigation plan of the proposed field sampling and laboratory testing to the Engineer for review and approval a minimum of 14 calendar days prior to commencing the geotechnical subsurface investigation. The Contractor shall submit the results of the geotechnical subsurface investigation and the pre-production laboratory testing plan to the Engineer for review and approval a minimum of 14 calendar days prior to commencing the pre-production laboratory testing. The results of the pre-production field and laboratory testing along with the proposed DSM binder mix designs shall be included in the DSM Installation Plan submittal in accordance with section 3.0.

4.1 Geotechnical Subsurface Investigation: In-situ soils used for the pre-production laboratory testing shall be obtained from additional subsurface investigation conducted at or near the location of the approved test section(s) locations. The Contractor shall retain the services of a geotechnical consultant to drill several 3-inch continuously sampled soil borings to obtain sufficient material to perform the pre-production laboratory testing. The sampling shall be performed in such a manner that provides continuous, representative samples of the soil column. This can be effectively accomplished via Geoprobe sampling techniques, undisturbed sampling in fine-grained soils, split-spoon sampling, or any other sampling technique proposed by the Contractor and approved by the Engineer.

Contractor shall check for utility conflicts at boring locations with appropriate utility agencies, survey boring locations and survey locations tied to the project baseline alignment. The borings shall extend from the ground surface to the bottom elevation of the DSM columns shown in the plans to establish general soil and groundwater conditions in the vicinity of the work prior to construction of the test section(s). The geotechnical investigation shall be done in conformance with the latest version of the SCDOT Geotechnical Design Manual (GDM). SCDOT practices including but not limited to boring logs and laboratory data reporting shall be used. The geotechnical consultant shall classify and record soil types within 7 days of obtaining the samples in the field. The Geotechnical consultant shall perform laboratory testing on representative samples of the entire soil profile that will be subject to ground improvement. As a minimum, test six representative samples of cohesive soils taken from different locations and four representative samples of cohesionless soils taken from different locations. The laboratory testing, as a minimum, will consist of the following:

- Cohesive and organic soils (i.e. peat) will be subject to laboratory tests that include, but not be limited to, moisture content, Atterberg limits, organic content, and unconfined compression tests.
- Cohesionless soils will be subject to laboratory tests that include, but not be limited to, grain size analysis, fraction passing #200 sieve, Atterberg Limits, and moisture content.

All soil samples to be used for the pre-production laboratory testing shall be stored in a manner that prevents any loss of moisture and in accordance with ASTM. Do not allow field samples of the clay to lose moisture between the time of removal from ground and pre-production laboratory mixing/testing.

4.2 Pre-Production Laboratory Testing. Pre-Production laboratory testing will require the development of a DSM binder mix testing program for each type of soil where ground improvement will be performed to

EXHIBIT 5 - SPECIAL PROVISIONS

demonstrate that the required 28-day compressive strength indicated in the plans will be achieved. The soils obtained from the geotechnical subsurface investigation performed (Subsection 4.1) will be used to perform the laboratory testing. All soil and mixed samples shall be kept out of sunlight at 70 degrees F and under fully humid conditions throughout storage and curing that prevents loss of sample moisture via evaporation.

DSM constructed using the wet mixing method (DSM-SCC) will require that the testing laboratory prepare the soil, mix the binder reagent (i.e. cement, etc.) and water to make grout, and then mix grout and soil together. The specimens shall be mixed using a minimum of four different DSM binder mixes to provide insight into the relationship of cement factor and grout water/cement ratio on the 28-day compressive strength of the soil-binder specimens. Binder materials and individual proportions of cement or admixtures (if used) used shall be documented for each specimen. The procedures outlined by Filz and Stewart (2005) may be used to provide guidance in developing a laboratory testing program.

DSM constructed using the dry mixing method (DSM-LCC) will require that the testing laboratory prepare the soil, binder reagent, and then mix the soil (at the same in-situ moisture) and binder reagent together. The specimens shall be mixed using a minimum of four different DSM binder mixes to provide insight into the relationship of binder proportions on the 28-day compressive strength of the soil-binder specimens. Binder materials and individual proportions of lime, cement, and admixtures (if used) used shall be documented for each specimen. The procedures outlined by Jacobson et. al (2003, 2005) may be used to provide guidance in developing a laboratory testing program.

All test specimens shall be prepared using the lab mixing energy level similar to energy levels used by the Contractor's field equipment. Test specimen cylinders shall be prepared according to procedures submitted to the Department and approved. Strength test three cylinders of soil-binder mixture at 3, 7, 14, 28, and 56 days following mixing. Strength testing shall be performed in accordance with subsection 8.4.

5.0 Delivery, Storage, and Handling of Materials.

5.1 DSM Wet Mixing Method (DSM-SCC): Portland cement shall be measured, handled, transported, and stored in bulk in accordance with the manufacturer's recommendations. Portland cement packaged in cloth or paper bags shall be sealed with plastic or rubber vapor barriers. The Portland cement shall be stored to prevent damage by moisture. Materials that become caked due to moisture absorption shall not be used. Bags of cement shall be stacked no more than ten bags high to avoid compaction. Cement containing lumps or foreign matter of a nature that may be deleterious to the grout mixing or delivery or injection operations shall not be used.

5.2 DSM Dry Mixing Method (DSM-LCC): The quicklime and cement shall be stored in closed pressure tanks suitable to be used as pressure vessels, for all pressures required, including those used to load and unload the materials. Delivery trucks shall be loaded at the manufacturer's plant unless approval is given for an intermediate storage facility. Each truck shall have a certified record of the weight of each load of material. The material shall be transported to the project site and blown into the on-site storage tanks using a pneumatic system. The air evacuated from the storage tanks during the loading process shall be filtered before being discharged to the atmosphere. A sealed refilling machine shall be used to transport material from the storage tanks to the DSM column mixing machine. This machine shall be refilled using a pneumatic system and an air filter, as specified above.

6.0 Installation Equipment. The DSM column construction equipment and support equipment shall be equipped with mixing tools that are capable of thoroughly blending the in situ soils and binder material into a homogeneous column of soil-binder to the depths and size required in the plans. The equipment shall be capable of advancing through previously installed and cured DSM columns as necessary for installing overlapping and end junction DSM columns. The DSM columns shall be constructed using computerized self-contained construction equipment.

6.1 DSM- SCC Construction Equipment: The DSM-SCC construction equipment shall meet the following requirements:

EXHIBIT 5 - SPECIAL PROVISIONS

1. DSM-SCC shall be constructed using real-time computerized self-contained DSM-SCC construction equipment capable of monitoring, controlling, and recording installation data. The DSM-SCC construction equipment shall be equipped with electronic sensors, built into the soil mixing equipment, to perform the following:
 - a. Determine vertical alignment of the leads in two directions: fore-aft and left-right. The verticality shall be measured using instrumentation that is capable of measure deviations from verticality to an equivalent of 1-inch in 100-feet.
 - b. Monitor cement and water proportioning, grout mixing, and water-cement ratios.
 - c. Monitor the mixing tool depth and penetration/withdrawal speed, and mixing tool rotation speed.
 - d. Monitor mixing tool withdrawal speed, and mixing tool rotation speed.
 - e. Monitor injection quantities and pressure with flow meter and other measuring equipment having precision accuracy not less than 99.5 percent.
 - f. All output from the sensors shall be routed to a console that is visible to the operator and the Engineer during penetration and withdrawal.
 - g. The sensors shall be calibrated at the beginning of the project and calibration data provided to the Engineer. The calibration shall be repeated at intervals not to exceed one month.
 - h. All of these monitored functions shall be fully adjustable during operation of the equipment.
2. The DSM-SCC construction equipment power source for driving the mixing tool shall be sufficient to maintain the required revolutions per minute (RPM) or injection pressure and penetration rate from a stopped position at the maximum depth required as determined from the test section(s) for group and/or block DSM column spacing. The Contractor shall also consider the wide range of expected subsurface conditions, indicated by the available geotechnical information.
3. The DSM-SCC construction equipment shall utilize sufficient mixing and injecting equipment to adequately produce a homogeneous distribution of cement grout throughout the mixed in-situ soils that meet the acceptable criteria. The mixing tools shall uniformly inject cement grout through hollow stem or other piping at locations that distribute the grout across the full diameter of the mixing tools and such that the full auger/mixing paddle assembly passes through the column of soil after the grout is introduced, on both the insertion and withdrawal strokes. Grout shall only be injected in direction within the diameter of the augers or mixing paddles. If grout injection jets are used, they shall not spray beyond the auger diameter.
4. Continuous auger flights longer than 3 feet or with more than one full, uninterrupted revolution of auger are not allowed as part of the mixing tools. Auger flights and mixing paddles on a shaft shall all reach to the full column diameter, and shall have discontinuous lengths and be so oriented as to thoroughly break up the in-situ soils, and disperse and blend soils with injected cement grout to form a homogeneous soil-cement mixture.
5. The auger mixing equipment shall form the required diameter and size of the DSM-SCC as submitted by the Contractor's approved submittals.
6. Injection volume estimates shall be only made by precision inline flow meters. Counting or measuring grout pump strokes shall not be acceptable. Injection quantities must be measured in real time by direct measurements of volume and/or mass for each DSM column having injection capabilities, with flow meters and other measuring equipment having precision accuracy not less than 99.5%. Gages and flow meters and other measuring equipment shall be calibrated and certified as precise and accurate before the start of the equipment's work on the project, and then again every 4 months.
7. The DSM-SCC construction equipment shall be adequately marked to allow the Engineer to confirm the penetration depth to within 6 inches during construction.

EXHIBIT 5 - SPECIAL PROVISIONS

8. The cement grout batching plant shall include all storage silos and sheds, pumps, scales, mixers, valves, gauges, and regulating devices required to continuously measure and mix cement grout in real time. Grout shall be mixed in a mixing plant, using a batch process, which combines dry materials and water in predetermined proportions. The plant mixer shall consist of grout mixer, grout agitator, grout pump, automatic batching scales, and a computer control unit. The mixing plant shall meet the following requirements:
 - a. To accurately control grout mix proportions, the addition of water and cement shall be determined by weight using automatic batch scales in the mixing plant.
 - b. Admixtures, if used, may be delivered to the mixing plant by calibrated auger provided the Contractor can demonstrate that the auger can deliver the material at the same accuracy as by weight.
 - c. The mixing components shall be calibrated prior to beginning the work and monthly thereafter. The calibration data shall be provided to the Engineer.
 - d. The mixing plant shall have tanks or silos with adequate storage for continuous production. The tanks shall be equipped with air filters.
9. Positive displacement pumps shall be used to transfer the grout from the mixing plant to the mixing tool. If the DSM-SCC construction equipment has multiple shafts, and multiple mixing tools, the grout shall be delivered to each shaft by an individual positive displacement pump.
10. All gauges, flow meters, metering equipment, and other measuring equipment shall be calibrated and certified as precise and accurate before starting DSM column construction (i.e. test section(s) or production DSM columns), and then again every 4 months or at least every 325,000 feet of DSM column installed, whichever is sooner. The calibrations and certifications shall be supplied to the Engineer.

6.2 DSM- LCC Construction Equipment: The DSM-LCC construction equipment shall meet the following requirements:

1. DSM-LCC shall be constructed using real-time computerized self-contained DSM-LCC construction equipment capable of monitoring, controlling, and recording installation data. The DSM-LCC construction equipment shall be equipped with electronic sensors, built into the soil mixing equipment, to perform the following:
 - a. Determine vertical alignment of the leads in two directions: fore-aft and left-right. The verticality to an equivalent of 1-inch in 100-feet.
 - b. Monitor the mixing tool depth, penetration/withdrawal speed, mixing tool rotation speed, and injection pressure.
 - c. All output from the sensors shall be routed to a console that is visible to the operator and the Engineer during penetration and withdrawal.
 - d. The sensors shall be calibrated at the beginning of the project and calibration data provided to the Engineer. The calibration shall be repeated at intervals not to exceed one month.
 - e. An alternative display/monitoring system may be used subject to review and approval by the Engineer prior to use.
 - f. All of these monitored functions shall be fully adjustable during operation of the equipment.
2. The DSM-LCC construction equipment power source for driving the mixing tool shall be sufficient to maintain the required revolutions per minute (RPM) or injection pressure and penetration rate from a stopped position at the maximum depth required as determined from the test section. The Contractor shall also consider the wide range of expected subsurface conditions, indicated by the available geotechnical information.
3. The DSM-LCC construction equipment shall be adequately marked to allow the Engineer to confirm the penetration depth to within 6 inches during construction.

EXHIBIT 5 - SPECIAL PROVISIONS

4. All gauges, flow meters, metering equipment, and other measuring equipment shall be calibrated and certified as precise and accurate before the starting DSM column construction (i.e. test section(s) or production DSM columns), and then again every 4 months or at least every 325,000 feet of DSM column installed, whichever is sooner. The calibrations and certifications shall be supplied to the Engineer.

7.0 Construction Requirements. The Contractor shall furnish all materials, labor and equipment necessary to construct the DSM columns in accordance with the plans and specification. The DSM columns shall be constructed to the lines, grades, and cross sections indicated in the Plans. The completed DSM improved zone shall be a homogeneous mixture of binder material constructed in accordance with the method of mixing and column spacing indicated in the plans.

Production DSM shall be constructed using the same equipment and construction criteria (i.e. mix design, mixing parameters, etc.) established in the accepted test section construction (subsection 9.0). DSM construction that is out of tolerance (subsection 7.4) or is subject to unforeseen conditions (subsection 7.5) shall be evaluated and corrected as approved by the Engineer with no additional cost or schedule impact to the Department.

7.1 Site Preparation: The presence and location of buried pipes, sewers, and other utilities shall be identified and precautions taken to protect the utilities from damage during the construction of the DSM columns. The Contractor shall be responsible for any damage resulting from the construction of the DSM columns. The site shall be cleared and grubbed in accordance with the Contract documents. Limit grubbing to that needed to remove previous construction materials, trees, stumps, and large roots. Fill in holes left by construction materials, stumps and root extraction and grade to provide level working surface. Place bridge lift materials as required in the plans and contract documents.

Establish DSM column limits and locations by a licensed surveyor. Individual column locations shall be marked. Sufficient horizontal and vertical control shall be provided to establish that DSM columns are located accurately and reach the required plan depths.

7.2 DSM-SCC Soil-Grout Mixing: Soil shall be broken up and blended with grout in place by the pugmill type action of the soil mixing equipment. The completed DSM-SCC shall be a uniform mixture of cement and the in situ soils. The soil-grout mixture shall achieve an average unconfined compressive strength in 28 days as indicated in the plans. Soil mixing shall be performed with the following minimum requirements:

1. *Grout Preparation:* The dry materials shall be fed to the mixers for agitation and shearing. The mixing ratio of the grout shall be controlled by measuring the weight of grout components using automatic batch scales in the mixing plant. Grout mixture shall be mixed for a minimum of three minutes, with a maximum holding time of two hours, calculated from the beginning of initial mixing. The specific gravity of the grout (determined in the test section) shall be tested at least once per shift per rig, using the methods outlined in ASTM D 4380, and shall not deviate more than three percent from the calculated specific gravity for the design cement ratio. Additional tests may be required by the Engineer. If the specific gravity or density is lower than the design mix, the Contractor shall add additional cement, remix, and/or recalibrate batch scales and retest the grout until the design density is achieved, at no additional cost to the Department.
2. *Grout Injection:* The grout shall be pumped through and injected from the mixing tool. The grout injection rate per vertical foot of DSM-SCC shall be in accordance with the requirements of the design mix established during the test section. Injection rates falling below this requirement, shall require the DSM-SCC to be remixed and additional grout injected (at the design grout-soil ratio) to a depth at least three feet below the deficient zone, at no additional cost to the Department. The Contractor may sample using wet grab methods for his own purposes. The Department will not accept results from wet sampling for quality control purposes.

EXHIBIT 5 - SPECIAL PROVISIONS

3. *Rotation Speeds:* The mixing tool rotational speeds (measured in RPM) and penetration/withdrawal rates shall be in accordance with the parameters established during the test section(s). If these parameters are varied more than 15 percent from those determined during the test section(s), the DSM-SCC section shall be remixed while injecting grout at the design grout ratio to a depth at least three feet below the deficient zone, at no additional cost to the Department.
4. *On-Board Computer:* The preset data in the on-board computer shall be verified for each column as correct and adjusted if necessary. The operator shall monitor and adjust as necessary during column installation the feeding of material, the grout injection rate, the mixing tool rates of rotation, and penetration/withdrawal rates of the mixing tool.
5. *Changes in Grout Mix Design:* The Contractor may request that the established grout mix be modified during the production DSM-SCC installation. To verify acceptable results for the modified mix design, the Engineer may require additional testing or a new test section, at no additional cost to the Department.
6. *Spoils:* During the course of soil-cement stabilization, return/spoil material shall not be dumped into or otherwise be allowed to enter the soil-cement column. The Contractor shall develop a spoil containment system that allows the channeling of the spoils to the temporary holding pit in such a direction and manner as to keep the spoils away from the site perimeter, and out of the traveled paths. Soil-cement return and spoil material shall be piped or channeled to holding ponds or other retention structures within the work area. The Contractor shall remove all excess grout and grout mixed soil generated from ground improvement activities from the construction site in accordance with the approved DSM Installation Plan.

The Contractor shall take all necessary precautions and implement measures to prevent any soil-cement return, other spoil material or stockpiled materials from entering storm drain structures, drainage courses, other utility lines, or from leaving the site via surface runoff. The Contractor shall prevent soil-cement return, fluid, ponded spoil material, or stockpiled solidified materials from migrating into any water body. In the event soil-cement return, spoil material or stockpiled materials enter storm drain structures, drainage courses, or other utilities, including, but not limited to, surface water bodies beyond site limits of soil-cement mixing operations, the Contractor shall collect and remove all of these materials, and perform all other required/necessary remediation that may be directed by the Engineer or responsible environmental agency, at no additional cost or schedule impact to the Department. The Contractor shall conduct all soil-cement operations to conform to sedimentation and turbidity control requirements of federal, state, and local agencies having jurisdiction over the work.

7. *Delays:* The installation of each DSM-SCC column shall be continuous without interruption. If an interruption of more than two hour occurs, the DSM-SCC shall be remixed for the entire column height using fresh cement grout as though there had not been any cement grout installed, or the column may be abandoned, at no cost or schedule impact to the Department. The Contractor shall install additional columns if the interrupted columns cannot be acceptably remixed.
8. *Instability:* Soil-cement column which exhibits partial or total instability at any time, or collapses as a result of mechanical failure of any equipment; inadequacy of cement, water supplies, cement grout; improper drilling, injection or mixing procedures; or other cause, the Contractor shall halt DSM-SCC construction and backfill to ground surface with cement grout. After the backfill has attained sufficient strength to stabilize the ground, complete the required installation by redrilling from ground surface, at no additional expense to the Department. The Engineer will evaluate the potential impacts of the instability and may require one or more additional redrilled columns at overlapping or adjacent locations as determined by the Engineer, and at no additional expense to the Department.
9. *Daily Quality Control Report:* The Contractor shall submit a Daily Quality Control Report for each day that DSM-SCC work is performed. The log shall contain as a minimum the information listed

EXHIBIT 5 - SPECIAL PROVISIONS

in Section 3.0. The report shall be delivered to the Engineer by the end of the next working day following the report date.

10. *Protective Covers:* Immediately after completing a soil-cement column, the Contractor shall install protective covers to prevent persons from falling or stepping into the unhardened soil-cement column.

7.3 DSM-LCC Soil-Binder Mixing: Soil shall be broken up with the mixing tool. As the mixing tool is raised the binder material (i.e. lime-cement or cement) is injected using air pressure. The binder-soil mixture shall achieve an average unconfined compressive strength in 28 days as indicated in the plans. Soil mixing shall be performed with the following minimum requirements:

1. *Binder Injection:* The binder (i.e. lime-cement or cement) volume flow rate per vertical foot of DSM-LCC shall be in accordance with the requirements of the design mix established during the test section. Injection rates falling 10 percent below this requirement, shall require the DSM-LCC to be remixed and additional binder injected (at the design rate) to a depth at least three feet below the deficient zone, at no additional cost to the Department.
2. *Rotation Speeds:* The mixing tool rotational speeds (RPM) and the penetration/withdrawal rates shall be in accordance with the parameters established during the test section(s). If these parameters are varied by more than 15 percent from those determined during the test section(s), the DSM-LCC section shall be remixed using the design binder volume flow rate to a depth of at least three feet below the deficient zone, at no additional cost to the Department.
3. *On-Board Computer:* The preset data in the on-board computer shall be verified for each column as correct and adjusted if necessary. The operator shall monitor and adjust as necessary during DSM column installation the feeding of material, the injection air pressure, and the rates of rotation and rise.
4. *Changes in Binder Mix Design:* The Contractor may request that the established mixing parameters be modified during the production DSM-LCC installation. To verify acceptable results for the modified parameters, the Engineer may require additional testing or a new test section, at no additional cost to the Department.
5. *Delays:* The installation of each DSM-LCC column shall be continuous without interruption. If an interruption of more than two hours occurs, the DSM-LCC shall be remixed for the entire column height using design binder rates as though there had not been any binder installed, or the column may be abandoned, at no cost or schedule impact to the Department. The Contractor shall install additional columns if the interrupted columns cannot be acceptably remixed.
6. *Daily Quality Control Report:* The Contractor shall submit a Daily Quality Control Report for each day that DSM-LCC work is performed. The log shall contain as a minimum the information listed in Section 3.0. The report shall be delivered to the Engineer by the end of the next working day following the report date.

7.4 DSM Column Construction Tolerances:

1. *Horizontal Alignment:* The location of the DSM column shown in the Plans shall be accurately staked by a licensed surveyor before beginning installation. The horizontal alignment of DSM columns with group column spacing (GCS) shall be within 4 inches of the planned DSM top location. The horizontal alignment of DSM columns with block column spacing (BCS) shall be within 20 percent of the DSM column diameter, not to less than four inches, of the planned DSM top location in order to obtain sufficient DSM column overlap.
2. *Vertical Alignment:* The equipment operator shall control vertical alignment of the equipment and constructed DSM column. Two measures of verticality shall be monitored, longitudinal and

EXHIBIT 5 - SPECIAL PROVISIONS

transverse to the DSM column alignment. The DSM column shall be installed at an inclination that deviates no more than 1:100 (horizontal to vertical).

3. *DSM Column Lengths:* The tops of the DSM columns shall begin at the ground surface. The top of DSM column elevations shown in the plans are approximate. Natural soils above the water table, at the completion of DSM installation, shall have been treated to produce the full column design strengths up to within 3 feet of the ground surface. If the top of the DSM columns is being constructed within a surcharge or berm, the top of DSM column elevations shown in the plans shall be used.

The bottom of DSM columns shall extend to the line and grades shown in the plans. The DSM column bottom elevations indicated in the Plans provide the minimum required penetration of the DSM columns. The Engineer may require the Contractor to shorten or deepen the bottom of DSM columns indicated in the plans.

4. *DSM-LCC Width:* When DSM columns are constructed using group column spacing (GCS) the DSM column diameter shown in the plans shall be the minimum required diameter. The diameter of DSM columns constructed using block column spacing (BCS) may vary to accommodate variations in the Contractor's equipment dimensions, provided that the plan area of ground improvement does not exceed the dimensions shown in the Plans more than six inches and is approved by the Engineer.

7.5 Unforeseen Conditions and Corrective Remediation: Unforeseen conditions that result in deficient DSM column construction shall be remediated by the DSM Contractor at no additional cost to the Department. DSM column construction deficiencies and how they were addressed shall be noted in the DSM Daily Production Control Report and Installation Log. DSM column deficiencies that result from changes in rotation speeds of mixing tools, rate of penetration/withdrawal of mixing tools, changes in the rate of grout/binder injection, delays, or changes in binder mix shall be corrected as indicated in subsections 7.2 and 7.3 for DSM-SCC mixing and DSM-LCC mixing, respectively.

If unforeseen conditions result in DSM column interruptions that do not meet the DSM construction requirements (subsections 7.2 or 7.3), the DSM column installation shall be re-drilled a minimum of 1 foot below the elevation of the interruption and the DSM column construction restarted.

When interruption of the installation process occurs because of unknown obstructions or a very dense layer above the planned tip elevation, the Contractor shall document the interruption on the DSM Daily Production Control Report and Installation Log and notify the Engineer in writing by the end of that day of such encounter and shall provide all pertinent information relating to DSM column identification, plan location coordinates, depth, and expected extent of the obstruction. The Contractor shall be prepared to penetrate very dense layers by first removing mixing tools from the excavation and then using auger drilling equipment or other approved methods to allow the installation of the DSM column. When unknown obstructions are encountered, the Contractor shall submit a proposal to the Engineer for review that delineates the Contractor's proposed means and methods to overcome the unknown obstruction, including equipment and labor time estimated for this operation. Such construction to remove an unanticipated obstruction shall only be performed with the written authorization of the Engineer. When the obstruction cannot be penetrated or removed, the DSM column shall be completed to the maximum depth penetrated. The need for an alternate design or remedial construction shall then be determined by the Engineer.

Deficient DSM columns due to out of tolerances (subsection 7.4) or not in compliance with DSM construction acceptance (subsection 7.6) will require that the DSM Contractor to submit proposed remedial measures to the Engineer for review and approval. Remedial plans shall show the location, depth, construction exceptions requested, and proposed method of remediating the deficient DSM ground improved areas. Remedial plans, if accepted, shall be at no cost or schedule impact to the Department.

7.6 DSM Construction Acceptance: The QC reporting (logs), testing, and acceptance procedures for the DSM test section(s) and production DSM columns shall be the same. QC testing methods are described in Section 8.0 and Acceptance Criteria are provided in Section 11.0.

8.0 DSM Testing Methods. QC testing of DSM columns consists of using field and laboratory testing techniques to evaluate the integrity, consistency, and strength of the DSM column for the entire full depth of soil improvement. QC testing methods that will be used include probe testing (subsection 8.1), soil borings and undisturbed sampling with Shelby tubes (subsection 8.2), and coring and sampling (subsection 8.3). Samples obtained by undisturbed sampling with Shelby Tubes or coring shall have samples tested for compressive strength testing (subsection 8.4). DSM testing shall be conducted in accordance with the SCDOT Geotechnical Design Manual, version 1.1 (2010), or later.

The results of the compressive testing shall be used to develop correlations for use with probe testing and therefore improve the reliability of the probe testing results. This will be accomplished by performing continuous undisturbed Shelby tube sampling and/or coring in one quadrant of the DSM column and probe testing in another quadrant of the same DSM column.

Any of the DSM testing methods presented may be used on production DSM columns to evaluate deficiencies based on construction records or field observations.

8.1 Probe testing:

1. Probe testing shall be conducted using the seismic cone penetrometer test with pore pressure measurements (SCPTu). The SCPTu testing results (i.e. tip resistance, friction sleeve resistance, pore pressure, and shear wave velocity vs. depth of penetration) shall be provided graphically and in electronic file format to the Engineer.
2. Probe testing shall be performed in the presence of the Engineer, unless otherwise directed. The Contractor shall notify the Engineer at least seven calendar days in advance and confirmed 2-days (48 hours) prior to beginning SCPTu operations.
3. The SCPTu testing shall be conducted in accordance with the SCDOT Geotechnical Design Manual.
4. Probe testing shall be performed after the soil-binder mixture has hardened sufficiently, but before it has cured to the extent to cause refusal to the SCPTu equipment.
5. Unless directed otherwise by the Engineer, probe tests shall be performed along an essentially vertical alignment located within one of the quadrants of the DSM column and shall include inclinometer measurements that confirm the verticality of the SCPTu test data such that the entire probe test is determined to have been advanced within the DSM column. The SCPTu shall be taken at a distance of 2/5 the DSM column radius from the center of the DSM column.
6. If seismic cone shear wave testing results are inconclusive, the SCPTu may be discontinued and cone penetrometer test with pore pressure measurements (CPTu) may be used with written approval from the Engineer.
7. The CPT testing equipment shall be sized to allow full penetration and testing to the depth of the planned test DSM column plus 10 feet.
8. If standard full-size CPT truck equipment (i.e. 20-30 ton reaction truck) is not capable of testing to the desired depths, the Contractor shall conduct SPT testing in accordance with the SCDOT Geotechnical Design Manual, at no additional cost to the Department. SPT shall be conducted on a maximum five foot center interval to the depth of the planned test DSM column plus 10 feet.
9. All probe test holes shall be filled with cement grout that will obtain 28-day strength equal to or greater than the DSM column compressive design strength required in the plans.

8.2 Soil Borings and Undisturbed Sampling:

EXHIBIT 5 - SPECIAL PROVISIONS

1. Soil borings and undisturbed Shelby tube sampling shall be performed in the presence of the Engineer, unless otherwise directed. The Contractor shall notify the Engineer at least seven calendar days in advance and confirmed 2-days (48 hours) prior to beginning soil boring operations.
2. Soil borings and sampling shall be conducted in accordance with the SCDOT Geotechnical Design Manual.
3. High quality undisturbed sampling shall be obtained after the soil-binder mixture has hardened sufficiently to a minimum compressive strength of 3 psi (430 psf) but not greater than 55 psi (7,900 psf).
4. Unless directed otherwise by the Engineer, soil borings shall be obtained along an essentially vertical alignment located within one of the quadrants of the DSM column. The soil boring shall be taken at a distance of $\frac{2}{5}$ the DSM column radius from the center of the DSM column.
5. Sampling shall be conducted using a thin wall Shelby tube sampler and/or pitcher barrel sampler in accordance with the SCDOT Geotechnical Design Manual.
6. Upon Shelby tube retrieval, the samples shall be logged visually without extraction of the samples from the Shelby tube and sealed to prevent loss of moisture during transport.
7. Undisturbed samples shall be transported by the Contractor to the independent AASHTO certified materials testing laboratory where the samples will be extracted, stored, and tested.
8. Upon extraction of the samples at the independent materials testing laboratory, the samples shall be logged and documented by taking pictures. The percent recovery per Shelby tube sampler based on the sampler penetration shall be documented. Samples shall be selected for testing and submitted to the Engineer for approval. Samples shall be stored and cured in accordance with ASTM D 1632 until the test date.
9. All soil boring holes shall be filled with cement grout that will obtain 28-day strength equal to or greater than the DSM column compressive design strength required in the plans.

8.3 Coring and Sampling:

1. Coring/sampling shall be performed in the presence of the Engineer, unless otherwise directed. The Contractor shall notify the Engineer at least seven calendar days in advance and confirmed 2-days (48 hours) prior to beginning coring/sampling operations.
2. High quality continuous core sampling shall be obtained after the soil-binder mixture has hardened sufficiently to approximately a compressive strength of 42 psi (6,050 psf).
3. Unless directed otherwise by the Engineer, core runs shall be obtained along an essentially vertical alignment located within one of the quadrants of the DSM column. The core run shall be taken at a distance of $\frac{2}{5}$ the DSM column radius from the center of the DSM column.
4. Coring shall be conducted using double or triple tube samplers to obtain samples of 2.5 inches in diameter or greater. Triple tube core barrel may be required by the Engineer, at no additional cost to the Department, if the sample quality of the double tube core barrel is not providing high quality samples suitable for compression strength testing.
5. Each core run shall be at least four feet in length and contain at least four acceptable test specimens. Three samples per core run are required to perform compressive strength testing with one reserve sample.
6. A minimum core run recovery of 85 percent for each 4-foot-long core run shall be achieved. During coring, the elevation of the bottom of the holes shall be measured after each core run in order that the core recovery for each run can be calculated. The core recovery and RQD for every core run shall be reported in the logs. Additional cores may be required, at no additional cost to the Department, if core run recovery is less than 85 percent.

EXHIBIT 5 - SPECIAL PROVISIONS

7. Upon retrieval, the samples shall be field logged and documented by taking pictures. Samples shall be selected for testing and submitted to the Engineer for approval.
8. Following logging and test specimen selection, the entire full-depth sample, including the designated test specimens, shall be immediately sealed in plastic wrap to prevent drying, placed in suitable core boxes, and transported to the materials testing laboratory by the Contractor within 24 hours.
9. All core holes shall be filled with cement grout that will obtain 28-day strength equal to or greater than the DSM column compressive design strength required in the plans.
10. Cores shall be transported by the Contractor to the independent AASHTO certified materials testing laboratory where the samples will be stored and tested. Samples shall be stored and cured in accordance with ASTM D 1632 until the test date.

8.4 Strength Testing of Samples:

1. All samples shall be kept out of sunlight at 70 degrees F and under fully humid conditions throughout storage and curing that prevents loss of sample moisture via evaporation.
2. Samples suitable for strength testing shall have a height to diameter ratio of 2.0.
3. Strength testing shall be performed by unconfined compression testing method per AASHTO specification T-208-96, but with strain rate not faster than 0.5% per minute, but not slower than 0.25%/minute, and with test equipment set up to record in both tabular and graphical form the axial stress and strain constant increments of axial strain no larger than every 0.05% axial strain. The Contractor will be permitted to perform UU Triaxial Compressive Tests, with approval of the Engineer, in lieu of performing unconfined compressive strength test, at no additional cost to the Department.
4. Compressive strength testing results shall be transmitted to the Engineer for review within 24 hours of the compression test completion. The remaining portions of the full-depth samples that are not tested shall be retained by the Contractor, until completion and acceptance of the work, for possible inspection and confirmation testing by the Engineer.

9.0 DSM Test Section and QC Testing Program.

The QC testing program for each test section will be submitted to the Engineer within 5 days after test section DSM column installation and shall be based on the results of DSM pre-production laboratory testing, early probe testing (3 and 5 days after column installation), and review of samples obtained for strength testing. The approved compressive strength testing program (i.e. Plan location, sample depth, and elapsed time after construction to perform compressive testing) shall then be submitted to the Contractor's independent AASHTO certified laboratory testing firm.

Unless otherwise directed by the Engineer, a minimum of four Plan locations shall have QC testing, per test section. QC testing at each Plan location shall consist of full-depth continuous soil borings or corings per subsections 8.2 and 8.3, respectively. Soil boring or coring sampling shall be performed in one DSM column quadrant, while probe testing, per subsection 8.1, shall be performed in another DSM column quadrant. A minimum of six samples at each QC testing Plan location shall be selected by the Contractor and approved by the Engineer for compressive strength testing. Compressive strength testing of cores (subsection 8.4) and probe testing (Section 8.1) at QC testing Plan locations shall be conducted at 7, 14, 28, and 56 days after test DSM column installation. The results of the compressive testing shall be used to develop correlations for use with probe testing and therefore improve the reliability of the probe testing results. A test DSM column compressive strength testing report shall be compiled by the independent testing company and submitted to the Contractor and the Engineer. The compressive strength testing report shall document the soil boring/core sampling and compressive strength testing conducted on the cores.

EXHIBIT 5 - SPECIAL PROVISIONS

In addition to probe testing conducted at QC testing Plan locations, full depth probe testing shall be conducted at two separate plan locations within the test section in separate DSM column quadrants at 3, 7, 14 and 28 days after test DSM column installation. A probe testing report shall be compiled of all testing results in accordance with Section 7.2.

The Contractor shall use the results of the test sections to establish the DSM production construction criteria. The DSM production construction criteria shall be developed to produce DSM columns that meet the Acceptance Criteria in Section 11.0. DSM production construction criteria for DSM columns shall include as a minimum, the following criteria.

DSM-SCC Production Construction Criteria:

1. Grout mix design including ratios of all materials mixed to form the grout.
2. Grout specific gravity.
3. Grout injection rates.
4. Type of equipment.
5. Mixing tool penetration and withdrawal rates.
6. Mixing tool rotation speed.
7. Construction procedures and techniques.

DSM-LCC Production Criteria:

1. Binder mix design including ratios of all materials (i.e. lime-cement or cement) mixed to form the soil-binder material.
2. Lime-cement injection rates.
3. Type of equipment.
4. Mixing tool penetration and withdrawal rates.
5. Mixing tool rotation speed.
6. Construction procedures and techniques.

The Contractor shall use the results of the test sections to establish the Production Quality Control (QC) testing program per Section 10.0.

Construction of production DSM columns may begin only after written acceptance by the Engineer of the "DSM Production Construction Criteria" and the "Production Quality Control (QC) Testing Program." If construction criteria, construction procedures, equipment, new mobilizations, or changes in personnel are made, following acceptance of the test sections, the Department reserves the right to require the Contractor to construct a new test section at no additional cost to the Department.

10.0 Production QC Testing Program.

The Production QC Testing program shall be developed by the Contractor and approved by the Engineer. The Production QC Testing program will be required to include probe testing per subsection 8.1 and strength testing of samples per subsection 8.4. The following minimum requirements shall be used to developing the Production QC Testing Program:

DSM QC Testing Program Minimum Requirements:

1. The Production QC Testing Program goal is to establish continuity/integrity of the columns and to obtain a measure of their strength. This is accomplished by using the QC Testing to evaluate if the DSM ground improvement is meeting the Acceptance Criteria in Section 11.0.
2. Provided that acceptable correlations can be developed between probe testing and compression strength testing, QC probe testing per subsection 8.1 shall be performed at a minimum frequency of 5 percent of production columns (1:20) but not less than 1 QC probe test for every 200 cubic yards of DSM stabilized volume.
3. One Soil boring/Coring full depth of DSM columns plus 10 feet with a minimum of one strength test per 5 feet of penetration of stabilized soil (Section 8.0) shall be obtained adjacent to probe testing

EXHIBIT 5 - SPECIAL PROVISIONS

(adjacent DSM quadrant) at a minimum frequency of 0.5 percent of production columns (1:200) but not less than 1 QC probe test for every 2,000 cubic yards of DSM stabilized volume.

4. If acceptable correlations cannot be developed between probe testing and compression strength testing, one Soil boring/Coring full depth of DSM columns plus 10 feet with a minimum of one strength test per 5 feet of penetration of stabilized soil (Section 8.0) shall be obtained adjacent to probe testing (adjacent DSM quadrant) at a minimum frequency of 1.0 percent of production columns (1:100) but not less than 1 QC probe test for every 1,000 cubic yards of DSM stabilized volume.
5. The QC Testing program shall define the limits of the production DSM testing based on the number of rigs operating, anticipated production schedule, and the minimum QC testing criteria defined above.
6. The QC Testing program shall include provisions for revising QC testing frequency as a result of failing DSM Acceptance Criteria, changes in construction criteria, construction procedures, equipment changes, new mobilizations, or changes in personnel that are made following acceptance of the test sections.
7. The Department reserves the right to require the Contractor to perform additional QC testing after review of the daily Quality Control Report/Log of the production DSM columns and/or review of QC Testing results. Although coring and conducting compressive strength testing of cores (Section 7.1) is not intended to be a routine QC testing method, the Engineer reserves the right to use this QC testing method based on the results of the probe testing at anytime.
8. The Contractor shall determine the time interval between DSM installation and QC testing. QC testing shall be performed on columns cured for a minimum of 3 days but no longer than 28 days, or as directed by the Engineer.
9. Only probe testing equipment and methods that have been calibrated during the test section shall be used for QC testing. If production DSM columns are being installed differently from the test section DSM column installation, a calibration of the probe testing with coring and compression testing shall be required unless approved otherwise by the Engineer.

11.0 Acceptance Criteria. Determination that the DSM columns meet the Acceptance Criteria (for DSM construction, DSM column continuity, and DSM compressive strength requirements) shall be evaluated solely by the Engineer based on a review of daily Quality Control Report/Log of the production DSM columns and QC testing results conducted by an independent testing company.

11.1 DSM Construction Acceptance Criteria: DSM columns shall be considered acceptable when daily Quality Control Report/Log of the production DSM columns and any remediation reports indicate that the:

1. Location of the top of the columns has been verified to be within design tolerances
2. Penetration of the column has been verified as correct by the Engineer.
3. Continuously recorded injection quantity of cement grout for DSM-SCC and binder (lime-cement or cement) for DSM-LCC columns has been verified to be within 10% of the design (preset) value established for the production DSM construction criteria based on the results of approved production DSM construction design criteria.

11.2 Evaluation of DSM Column Continuity: Lumps of unimproved soils shall not amount to more than 15 percent of the total volume of any 4-foot section of continuous full-depth evaluation by either conducting continuous probe testing, soil borings, or coring. Any individual or aggregation of lumps of unimproved soil shall not be larger than 6 inches in greatest dimension. For evaluating the volume of unimproved lumps of soil, all of the unrecovered samples shall be assumed to be unimproved soil. In addition, within a sample, the sum length of unmixed or poorly mixed soil regions or lumps that extend entirely across or a portion thereof the diameter of the sample will be considered unimproved.

11.3 Design Compressive Strength Acceptance: Unless directed otherwise by the Engineer, all DSM QC compressive strength test results shall indicate a minimum of 60 percent of the design compressive strength at 5 days or less. Failure to meet this criterion shall deem the DSM column to be in non-conformance of the DSM compressive strength acceptance criterion. The DSM column shall be retested (same DSM column, different quadrant) at 28 days where the average QC strength testing shall indicate

EXHIBIT 5 - SPECIAL PROVISIONS

100 percent or more of the compressive design strength with no sample testing less than 85 percent of the compressive design strength. Failure to meet the 28 day QC strength testing criterion shall deem the DSM column to be in non-conformance of the DSM compressive strength acceptance criteria. The Contractor may elect to conduct additional QC strength testing in excess of 28 days, with approval of the Engineer, at no additional cost to the Department. Unless otherwise determined by the Engineer, the extent of the non-conformance QC test area shall be considered to include all DSM constructed during all rig shifts that occurred after construction when passing tests were achieved. Non-conforming DSM QC test areas shall be remedied by the Contractor by conducting the following procedures.

The Contractor may conduct two or more additional QC probe tests (locations designated by the Contractor and approved by the Engineer) to better define the limits of the non-conformance and submit the results of those tests for review by the Engineer at no additional cost to the Department. If a minimum of 60 percent of the design strength has been achieved at 5 days or less, the Engineer shall evaluate the DSM construction documentation to determine which DSM columns are in conformance. If compressive strength criteria are achieved, with approval of the Engineer, all or a portion of the production DSM QC testing area may be approved provided that any deficient production DSM columns are remedied by one of the following two options. Failure to meet the required design strength of the additional DSM QC testing shall require that the DSM QC test area be remedied by one of the following options as approved by the Engineer.

1. Provide 2 or more additional QC tests (locations designated by the Engineer) within the DSM QC test area which demonstrate that at 28 days, the average QC strength testing is 100 percent or more of the compressive design strength with no sample testing less than 85 percent of the compressive design strength.
2. Re-drilling all or a portion of the nonconforming DSM QC test area and mixing additional cement grout for DSM-SCC columns or binder material (lime-cement or cement) for DSM-LCC, while raising the mixing tool. The Contractor shall submit a proposed plan for remixing or repair of failed sections for review and approval by the Engineer. Repair work of failed DSM columns shall be performed at no additional cost to the Department. Changing grout or binder quantities may require additional QC testing to calibrate QC probe testing. After reconstruction of the production DSM-LCC testing section, the affected DSM-LCC testing section will be subject to the compressive strength acceptance criteria as defined in this section.

12.0 As-Built Plans. Following completion of the production DSM column construction, the Contractor shall furnish to the Engineer a set of as-built plans detailing the locations of the DSM columns in terms of project coordinates, top and bottom elevations, QC compressive strength testing results, and any other dimensions of the DSM columns that are pertinent to the project.

13.0 Measurement and Payment. DSM constructed using group columns spacing (GCS) will be measured per linear foot of DSM column constructed and then accepted by the Engineer. DSM constructed using block column spacing (BCS) will be measured by the total neat-line ground improved volume (in cubic yards) accepted by the Engineer, where the neat-line is the rectangular plan area of the required ground improvement zone times the specified improvement depth. Material located outside of the tolerances specified will not be measured. Material used to remix an area found to be unacceptable to the Engineer will not be measured. The test section(s) will not be measured, and is considered incidental to the production DSM ground improvement.

Payment will be made at the unit contract price per linear feet for DSM constructed using group columns spacing (GCS) and per cubic yard for DSM constructed using block column spacing (BCS). Payment for DSM columns will be full pay to perform the work as specified including construction and testing of test sections, QC testing, construction and removal of surcharges and berms, handling and hauling of excavated spoils, and site cleanup.

Payment will be made under:

EXHIBIT 5 - SPECIAL PROVISIONS

Item No.	Pay Item	Pay Unit
2051201	Ground Improvement (Deep Soil Mixing Soil-Cement Columns - BCS)	CY
2051202	Ground Improvement (Deep Soil Mixing Soil-Cement Columns - GCS)	LF
2051203	Ground Improvement (Deep Soil Mixing Lime-Cement Columns- BCS)	CY
2051204	Ground Improvement (Deep Soil Mixing Lime-Cement Columns- GCS)	LF

(72) DIVISION 200: GEOGRID SOIL REINFORCEMENT

June 17, 2010

Division 200 is expanded as follows:

1.0 Description. This work shall consist of furnishing primary geogrid soil reinforcement in accordance with these specifications.

2.0 Reference Documents. The latest edition of the test standards shall be used. Substitution of standards will require the prior written approval of the Research and Materials Engineer.

3.0 Material. Geogrid design requirements shall be as shown in the plans and specified in the design drawings. Geogrid soil reinforcement shall consist of a regular network of integrally connected polymer tensile elements with aperture geometry sufficient to permit significant mechanical interlock with the surrounding soil, aggregate, or other material. The structure of the geogrid reinforcements shall be dimensionally stable and able to retain its geometry under construction stresses and shall have high resistance to damage during construction, to ultraviolet degradation, and to all forms of chemical and biological degradation encountered in the soil being reinforced.

3.1 Primary Reinforcement. Primary geogrids shall provide the following minimum allowable long-term reinforcement tension load, T_{al} .

Property	Method	P1⁽³⁾	P2	P3	P4	P5	P6	P7
Allowable Long-term Tension Load, T_{al} ^{(1) (2)} (lb/ft)	FHWA NHI-00-043	450	800	1450	2300	3000	3600	4000

⁽¹⁾ Minimum T_{al} in machine direction unless otherwise specified

⁽²⁾ Minimum pullout friction factor $F^* = C_i \tan \Phi$, where soil interaction coefficient, $C_i \geq 0.6$

⁽³⁾ Biaxial Geogrid – Minimum T_{al} in strong direction, minimum T_{al} in weak direction is 360 lb/ft.

where $T_{al} = \frac{T_{ult}}{RF}$ and $RF = RF_{CR} \times RF_D \times RF_{ID}$ and $RF \geq 3.0$

EXHIBIT 5 - SPECIAL PROVISIONS

3.2 Secondary Reinforcement. Secondary reinforcement, Type S1, shall meet the following minimum average physical properties:

Property	Method	Value
1. Tensile Strength ⁽¹⁾ a. 5% strain, lb/ft ⁽²⁾ b. Ultimate Tensile Strength, T _{ult} (lb/ft) c. Allowable Long-Term Strength, T _{al} (lb/ft)	ASTM D 4595 ASTM D 4595 FHWA NHI-00-043	800 1400 200
2. Apparent Opening Size	ASTM D 4751	>50, <80

NOTE: ⁽¹⁾ In direction perpendicular to the slope face.

⁽²⁾ No offset allowance is permitted.

4.0 Certification. Prior to construction the Contractor shall submit to the Geotechnical Design Engineer (GDE) a Certification Package prepared by the geogrid reinforcement manufacturer. The Contractor shall allow 15 calendar days from the day the submittals are received by the GDE for review and acceptance. The Certification shall state that the furnished geogrid soil reinforcement is in full compliance with the design requirements as stated in this specification and the design drawings and is fit for use in long-term critical soil reinforcement applications. The submittal shall certify the following values for each geogrid soil reinforcement used on the project:

1. The allowable long-term tensile load, T_{al}, for geogrid soil reinforcements
2. The ultimate tensile strength, T_{ULT}, (MARV) for geogrid soil reinforcements.
3. The geogrid's pullout coefficients (F*, α)

The manufacturer shall also provide written certification that the material is capable of withstanding direct exposure to sunlight for 120 days with no measurable deterioration as measured per ASTM D 4355. The Contractor's submittal package shall include, but not be limited to, actual test results for tension, creep, durability, construction damage, joint strength, pullout and quality control. A person having the legal authority to bond the manufacturer shall attest to the certificate. Any tests required shall be performed at no additional cost to the Department. If in the opinion of the GDE, the required documentation is not provided for individual reduction factors (RF) or pullout coefficients (F*, α), default values for these design parameters shall be used in accordance with this specification.

The submittal shall certify the following values and document for each geogrid soil reinforcement used on the project:

4.1 Ultimate Tensile Strength (T_{ult}): The ultimate tensile strength, T_{ult}, shall be determined from wide width tensile tests (ASTM D 4595) or rib tensile test for geogrids (ASTM D 6637). Geogrid samples tested in accordance with ASTM D 4595 shall have at least two geogrid apertures and a minimum gage length of 4 inches. All geogrid strength tests (ASTM D 4595 and ASTM D 6637) shall be conducted at a strain rate of 10% per minute based on actual gage length necessary to meet the testing sample dimension requirements. Laboratory test results documenting the ultimate tensile strength, T_{ult}, in the reinforcement direction shall be based on the minimum average roll values (MARV) for the product.

4.2 Allowable Long-term Tensile Load (T_{al}): The allowable tensile load, T_{al}, per unit width of geosynthetic soil reinforcement in accordance to the backfill type used shall be computed as follows:

$$T_{al} = \frac{T_{ult}}{RF}$$

4.3 Reduction Factor (RF): The total reduction factor, RF, is the combined reduction factor for long-term degradation due to installation damage, creep, and durability. The total reduction factor, RF, shall be defined as follows:

EXHIBIT 5 - SPECIAL PROVISIONS

$$RF = RF_{ID} \times RF_{CR} \times RF_D \geq 3.0$$

The individual reduction factors shall be documented in accordance with the site conditions, design calculations, and specifications. When sufficient documentation is not provided for individual reduction factors, RF_{ID} , RF_{CR} , and RF_D , a reduction factor RF of 7.0 shall be used. The reinforcement manufacturer shall certify and document the individual reduction factors as follows:

4.3.1 Installation Damage Reduction Factor (RF_{ID}): The reduction factor for installation damage, RF_{ID} , shall be documented by field and laboratory test results and literature review, as described in ASTM D 5818 for the reinforced backfill specified or for more severe soils. Samples subjected to installation damage shall be tested for tensile strength and deformation characteristics in accordance with ASTM D 4595 (modified for geogrid testing). Recommended values for reduction factors for installation damage (RF_{ID}) for various soils shall also be documented. The minimum installation damage reduction factor, RF_{ID} , shall be 1.1, regardless of product specific test results.

4.3.2 Creep Reduction Factor (RF_{CR}): Laboratory test results documenting creep performance over a range of load levels, for a minimum duration of 10,000 hours based on tension creep test (ASTM D 5262) shall be required. Creep test samples shall be of sufficient width to be representative of overall product creep response (fiber creep testing will not be accepted).

The creep-limiting strength, T_i , shall be based on extrapolating the 10,000 hours (or longer duration) tension creep tests to a 75-year design life, unless a 100-year design life is specified in the plans. The creep extrapolation method shall be based on methods described in FHWA NHI-00-43, "*Mechanically Stabilized Earth Walls and Reinforced Soil Slopes*" - Appendix "B". Laboratory test results and extrapolation methodology shall be documented.

The reduction factor for creep, RF_{CR} , is defined as the ratio of the average lot specific ultimate tensile strength, T_{ULTLOT} , to the creep-limiting strength, T_i . The average lot specific ultimate tensile strength, T_{ULTLOT} , for the lot of material used for creep testing, T_{ULTLOT} , shall be determined from wide width tensile test, ASTM D 4595, (modified for geogrid testing).

4.3.3 Durability Reduction Factor (RF_D): The total reduction factor for durability, RF_D , shall be defined as the combined effects of chemical and biological degradation. Laboratory test results, extrapolation techniques, and a comprehensive literature review shall document the reduction factor for durability for all material components in accordance with FHWA NHI-00-044, "*Corrosion/Degradation of Soil Reinforcements for Mechanically Stabilized Earth Walls and Reinforced Soil Slopes*". The minimum durability reduction factor, RF_D , shall be 1.1, regardless of product specific test results.

4.4 Soil Reinforcement Pullout Coefficients (F^* , α): The Certification Package shall document the pullout coefficients (F^* , α) meet or exceed the required coefficients necessary to obtain the T_{al} provided above.

The pullout friction factor, F^* , and the scale effect correction factor, α , shall be documented by laboratory testing from pullout tests. Pullout testing shall be conducted for site-specific materials or for materials representative of the reinforced backfill at confining pressures ranging from 2 to 10 psi. When laboratory tests are used from representative soils, the representative soils shall be documented by providing the soil's angle of internal friction, gradation, and coefficient of uniformity ($C_u = D_{60}/D_{10}$). Recommended pullout coefficients for various soil types shall also be documented. The pullout coefficients shall be determined by using the quick effective stress pullout tests ("Measuring Geosynthetic Pullout Resistance in Soil" per ASTM D 6706) and through-the-junction creep testing of the geogrid per ASTM D 5262. The soil interaction coefficient, C_i , shall be documented when computing the pullout friction factor, F^* . When sufficient documentation is not provided for pullout coefficients, F^* and α , and the coefficient of uniformity, C_u , is greater or equal to 4, the default values indicated in this specification can be used. If the coefficient of uniformity of the reinforced backfill is less than 4, laboratory pullout test shall be required to determine pullout friction factor, F^* , and the default scale effect factor, α .

EXHIBIT 5 - SPECIAL PROVISIONS

5.0 Manufacturing Quality Control. The Contractor shall provide to the RCE a manufacturing quality control certificate and conformance testing results for all geosynthetic soil reinforcement delivered to the site. Sampling and conformance testing shall be in accordance with ASTM D 4354. Geosynthetic product acceptance shall be based on ASTM D 4759. Geogrid samples tested in accordance with ASTM D 4595 shall have at least two geogrid apertures and a minimum gage length of 4 inches. All geogrid strength tests (ASTM D 4595 and ASTM D 6637) shall be conducted at a strain rate of 10% per minute based on actual gage length necessary to meet the testing sample dimension requirements. Laboratory test results documenting the ultimate tensile strength, T_{ult} , in the reinforcement direction shall be based on the minimum average roll values (MARV) for the product. Conformance testing of the applicable index testing shown in Table 5.0 shall be provided for all geosynthetic soil reinforcement. The quality control certificate shall include roll numbers and identification, sampling procedures, and results of the conformance testing with a description of test methods used. The geogrid manufacturer shall have a manufacturing quality control program that includes QC testing no less frequently than each 200,000 sf (20,000sm) of production.

Table 5.0 – Applicable Index Testing

Type	Property	Test Method	Criteria
Polypropylene (PP)	UV Oxidation Resistance	ASTM D 4355	Minimum 70% strength retained after 500 hrs. in weatherometer
	Melt Flow Rate	ASTM D 1238	≤ 12 g/10 min
Polyethylene (HPDE)	UV Oxidation Resistance	ASTM D 4355	Minimum 70% strength retained after 500 hrs. in weatherometer
	Melt Flow Rate	ASTM D 1238	< 0.4 g/10 min
	Specific Gravity	ASTM D 792	1.2 Average
Polyester (PET)	Hydrolysis Resistance	Intrinsic Viscosity Method (ASTM D 4603 and GRI Test Method GG8) with Correlation or Determine Directly Using Gel Permeation Chromatography	Minimum Number Average Molecular Weight of 25,000
	Hydrolysis Resistance	GRI GG7	Maximum Carboxyl End Group (CEG) Content of 30
All Polymers	Survivability	Weight per Unit Area ASTM D 5261	Minimum 270 g/m ² (7.9 oz/yd ²)
	% Post Consumer Recycled Material by Weight	Certification of Material Used	Maximum 0%

6.0 Measurement and Payment. All costs for installing the geogrid soil reinforcement (primary and secondary) is to be included in the amount bid for the pay items below.

Measurement of primary and secondary geogrid soil reinforcement is on a square yard basis and will be computed based on the total area of primary or secondary geogrid soil reinforcement shown in the plans, exclusive of the area of geogrids used in any overlaps. Overlaps and any geogrid waste are an incidental item. The quantity of primary geogrid soil reinforcement (biaxial or uniaxial) shall be paid at the contract unit price for Geogrid Reinforcement.

Payment will be made under:

Item No.	Pay Item	Pay Unit
2037000	Geogrid Reinforcement (Uniaxial)	SY

EXHIBIT 5 - SPECIAL PROVISIONS		
--------------------------------	--	--

2037010	Geogrid Reinforcement (Biaxial)	SY
---------	---------------------------------	----

(73) DIVISION 200: GROUND MODIFICATION – VIRBRO STONE COLUMN

(VIBRO DISPLACEMENT)

January 9, 2013

Division 200 is expanded as follows.

1.0 DESCRIPTION

This section presents vibro-displacement requirements for ground modification by stone column (SC) construction at both bridge approaches using the dry bottom feed method. This Special Provision details the technical and quality assurance requirements for furnishing all supervision, labor, material, equipment, and related services necessary to construct all soil improvements by vibro-displacement. The construction work includes subsurface soil improvement by vibro-displacement and delivery and placement of all backfill necessary in the improvement process. Soil improvement by vibro-displacement method shall be provided in the areas shown in the roadway plans and as required by this Special Provision. Ground modification is for mitigation of settlement due to consolidation, settlement due to liquefaction and embankment stability.

The Contractor or Sub-contractor performing the vibro-displacement construction shall be one who can provide a minimum 5 year experience record documenting 15 recent successful projects completed with specific application to these site conditions, ground modification technique, and soil improvement criteria. References asserting this documentation shall be provided upon request. The Contractor must have sufficient production capacity to produce the required work without causing delay to the project.

The Contractor shall layout, and measure the locations for vibro work. Vibro points may be surveyed in or located by measuring offsets from surveyed points (e.g., project stations) using a tape measure.

The Contractor shall notify the Engineer 48 hours prior to commencement of the vibro operations.

The Contractor shall submit plans and shop drawings to the Engineer for review and approval at least 30 days prior to work beginning, indicating the sequence, spacing, location, and depth of the vibro points to achieve the criteria outlined in this specification and shown in the roadway plans. Any change in the predetermined vibro program necessitated by a change in the subsurface conditions shall be immediately reported and submitted to the Engineer. Upon completion of the work, the Contractor shall submit a drawing of as-built locations of the stone columns.

2.0 MATERIALS

The backfill for vibro-displacement shall consist of hard, durable crushed gravel or crushed stone with a gradation consistent with #57 sized crushed aggregate (meeting ASTM C33 coarse aggregate requirements). Fossiliferous or soft limestone materials shall not be used.

The Contractor shall submit certifications and test reports that indicate the backfill materials meet specified requirements prior to commencing field work.

3.0 CONSTRUCTION METHODS

EXHIBIT 5 - SPECIAL PROVISIONS

Prior to commencing work, the Contractor shall examine the following: site conditions, drawings, records of existing utilities and other existing subsurface structures, and Geotechnical Reports, including soil boring logs. This data will be made available by the Engineer to help determine vibro-displacement installation conditions.

Data on indicated subsurface conditions is provided solely for convenience of the Contractor. It is expressly understood that the Department, Engineer, or the Engineer's sub-consultants will not be responsible for interpretations or conclusions drawn therefrom by the Contractor. The Department and Engineer expressly encourage the Contractor to perform soil test borings or other subsurface explorations to determine whether the Contractor's proposed ground modification method is capable of installing the specified vibro-displacement stone columns. If the Contractor needs additional test borings and other exploratory operations, they may be conducted at no additional cost to the Department.

The vibro-displacement stone columns shall be constructed prior to bridge foundations. Positive site drainage shall be established prior to construction of the vibro-displacement stone columns. Contractor shall control all spoils generated during vibro-displacement stone column construction and prevent spoils from flowing offsite. Spoils generated by vibro-displacement stone column construction shall be disposed of properly and removed from the site by the Contractor. No additional compensation shall be made for handling spoil.

Vibro-displacement stone columns shall be constructed at the locations shown on the project roadway plans and in accordance with this special provision.

If stone columns are installed through embankment fill that will be later excavated, #57 stone should be used to backfill the portion above the excavation limit. No payment will be made for stone columns installed within areas that are later excavated. The contractor shall be responsible to construct vibro-displacement stone columns to the depths required, and shall use the methods necessary to penetrate to the required depth, including but not limited to pre-augering through stiff and dense layers that may be present, as well as obstructions from existing construction.

The stone columns shall be installed to the minimum required Area Replacement Ratio. The required minimum area replacement ration (A_r) achieved at any depth by the vibro-displacement stone columns shall be that which is equivalent to 36-inch diameter stone columns spaced 8 ft. center-to-center (c-c) on a triangular pattern.

The area replacement ratio shall be defined by the following relationships:

$$A_r = \frac{\text{Stone Column Area}}{\text{Tributary Area}} \times 100\%$$

Where: Stone Column Area = Area of circle based on column diameter as defined below.
Tributary Area = $0.866 (\text{Column Spacing})^2$ for triangular spacing

Acceptance of the constructed column will be based on the theoretical column diameter determined from the volume of backfill installed and an assumed relative density of compacted washed stone equal to 90%.

The Contractor shall, at all times, protect structures, underground utilities and other construction from damage caused by vibro operations. Damaged material shall be replaced or repaired to the satisfaction of the Engineer at no additional cost to the Department.

At no time during stone column installation will the use of water be allowed to flush soil cuttings from mitigated zone.

The Contractor shall:

EXHIBIT 5 - SPECIAL PROVISIONS

1. Verify the location of existing underground utilities by excavation before starting vibro operations. If utility lines are to remain in place, provide protection from damage during vibro operations.
2. Consult the Engineer immediately for directions as to procedure if uncharted or incorrectly charted piping or other utilities are encountered during excavation or execution of work. Cooperate with Department and public or private utility companies in keeping their respective service and facilities in operation. Repair damaged utilities to satisfaction of utility Department at no additional cost to Department.
3. Ensure that existing utilities serving facilities occupied by Department or others are not interrupted, except when permitted in writing by Engineer and then only after temporary utility services have been provided.
4. To ensure that stone columns for vibro-displacement are not installed at locations designated for future structural piles, installation should only be conducted at the locations shown on the roadway plans.

A pre-job conference is required between Engineer and Contractor(s), to review special requirements for work. Conference shall be arranged by Contractor and shall be planned sufficiently in advance of work to allow required attendees adequate notice (one week minimum) to make arrangements to attend.

The Contractor shall use a down-hole vibrator capable of providing at least 160 horsepower and 20 tons of force.

Specific equipment and procedural specifications are left to the Contractor to achieve the specified criteria. However, the following general guidelines are identified:

1. After penetration to the treatment depth, the vibrator should be slowly retrieved in 12-inch to 18-inch increments to allow backfill placement.
2. The vibrator should be re-driven through each increment into a recently treated depth interval to observe amperage buildup or increase (or equivalent pressure increase for hydraulic vibrators).
3. Amperage buildup and backfill quantities are contingent to the type of vibrator, type of backfill, in situ soil conditions, and Contractor's procedure. Discussion between the Engineer and Contractor shall be conducted prior to work regarding individual equipment capabilities and expectations.

4.0 QUALITY CONTROL

Various production columns shall be evaluated by the Engineer on the basis of volume backfill installed per vibro point. Standard and/or Cone Penetration Testing (SPT and/or CPT) will also be performed by the Engineer to explore specific production columns. The test locations shall be determined by the Engineer once the plans and shop drawings have been received from the Contractor and reviewed, but will typically be as shown on the SC Testing Detail in the project plan sheets. The Contractor shall inform the Engineer 30 days prior to the installation of the first production column so that the field testing can be scheduled appropriately.

The Engineer reserves the right to perform tests and to prepare test reports on items stated below.

The Engineer will make continuous inspections of vibro operations to determine the following:

- a. Proper depth of penetration is obtained
- b. Volume of backfill material installed per vibro point
- c. Theoretical column diameter

EXHIBIT 5 - SPECIAL PROVISIONS

The Contractor shall furnish a complete log for each vibro point on the project, to include the following:

- a. Column identification
- b. Date of installation
- c. Recording of probe number
- d. Start/finish time of probe
- e. Approximate backfill quantities
- f. Diameter of column
- g. Location of column
- h. Existing ground surface elevation
- i. Top and bottom elevation of each column

The acceptance criteria for the stone columns shall be the diameter and spacing to create the required minimum area replacement ratio.

5.0 MEASUREMENT AND PAYMENT

The quantity of ground modification measured for payments shall be the actual length of the installed stone columns acceptable to the Engineer. No payment will be made for ground modification beyond the limits required by the Contract Documents, unless such increases in the specified area are ordered by the Engineer in writing.

The accepted quantity, measured as above, will be paid for at the contract unit price per linear foot for Ground Modification, which price and payment shall be full compensation for mobilization, demobilization, furnishing, hauling, treating, compacting of materials, removal of spoils, constructing working platform, pre-augering/obstructions and for all labor, equipment, tools, maintenance, and incidentals necessary to complete this item of work.

Payment will be made under:

<u>Item No.</u>	<u>Pay Item</u>	<u>Pay Unit</u>
2051112	Ground Modification – Vibro-Stone Column	Linear feet

(74) DIVISION 200: LIGHTWEIGHT AGGREGATES

1.0 Description. This work shall consist of furnishing, loading, hauling, placing and compacting lightweight aggregates (either man-made or natural) for use as fill materials in accordance with these specifications. The lightweight aggregate must be manufactured by expanding shale, clay, or slate in a rotary kiln operation or be naturally made. Wood fiber, blast furnace slag, fly ash, shredded tires, or boiler slag will not be allowed. The material must be sub angular to angular conforming to ASTM C 330 (latest edition). The material requirements presented in this specification are appropriate for borrow materials placed in embankments or placed as retained materials. If lightweight aggregates are used as reinforced backfill materials for the construction of Mechanically Stabilized Earth (MSE) walls or other reinforced soil structures, additional material properties, construction, and testing frequency requirements may be required based on the appropriate specifications.

2.0 Material. The Lightweight aggregate must have a proven record of durability, be non-corrosive, and conform to the following requirements:

- pH (AASHTO T-289): pH values shall range between 5 and 10.
- Organic Content (AASHTO T-267): Organic content shall be less than 0.1 percent (weight of organic material to weight of total sample).

EXHIBIT 5 - SPECIAL PROVISIONS

- Soundness Loss (AASHTO T104): Soundness loss shall be less than 15% when subjected to 5 cycles of Sodium Sulfate.
- Los Angeles Abrasion (AASHTO T96): Abrasion loss shall be less than 45%.
- Chloride Content (AASHTO T291): Chloride content shall be less than 100 ppm.
- Sulfate (AASHTO T-290): Sulfate content shall be less than 200 ppm.
- Resistivity (ASTM D1125): Resistivity must be greater than 3000-ohm-cm. If resistivity is greater than 5000-ohm-cm, chloride and sulfate requirements and testing are waived.
- Absorption (AASHTO T19): Absorption must be less than 6%.
- Gradation (ASTM 136): The gradation will be as shown in the following Table. Other gradations may be acceptable upon approval by the Engineer.

Table – Lightweight Aggregate Gradation

Sieve Size or Number	Percent Passing
¾ inch	100
½ inch	90 – 100
3/8 inch	50 – 90
No. 4	0 – 50
No. 8	0 – 20
No. 16	Less than 10
No. 30	Less than 10
No. 50	Less than 5
No. 100	Less than 5

- The coefficient of uniformity, C_u , shall be 4 or greater. The coefficient of uniformity, C_u , shall be computed as follows:

$$C_u = \frac{D_{60}}{D_{10}}$$

Where D_{60} is the particle diameter at 60% passing and D_{10} is the particle diameter at 10% passing. Written approval from the DOC will be required to use soils with a coefficient of uniformity, C_u , less than 4.

- Aggregate loose unit weight (ASTM C29): The loose unit weight must be less than 45 lbs/ft³.
- In-place density: (ASTM D4253, and D4254): The in-place compacted dry unit weight must be between 55 and 60 lbs/ft³. Material must be compacted to a minimum 65% relative density as determined by ASTM D4253 and D4254. Use a vibratory table when determining the maximum index density and unit weight in accordance with ASTM D4253. Determine the minimum index density and unit weight in accordance with ASTM D4254.
- Angle of Internal Friction (AASHTO T 236): The minimum angle of internal friction must be 40 degrees. Test a saturated representative sample (with particles larger than larger than 0.75 inch removed) in a round or square shear box that is a minimum of 12 inches across. Test sample shall be compacted to a minimum 65% relative density as determined by ASTM D4253 and D4254.

3.0 Construction. Place the lightweight fill in uniform layers. When required by the Engineer, compact each layer using vibratory compaction equipment weighing no more than 10 tons. Place layers no more than 12 inches in depth loose thickness and compact. Compact with three passes of an 8 – 10 ton vibratory roller in the vibratory mode if necessary, or as directed by the Engineer. In confined areas use vibratory plate compaction equipment (5 hp to 20 hp) with a minimum of two passes in 6" lifts for a 5 hp

EXHIBIT 5 - SPECIAL PROVISIONS

plate and 12” lifts for a 20 hp plate. The contractor must take all necessary precautions when working on or near the lightweight fill to ensure that the material is not over compacted. Construction equipment, other than for placement and compaction, must not operate on the exposed lightweight fill. Low ground pressure equipment (D6 LGP or lighter) is recommended for spreading and placing the lightweight aggregate.

4.0 Testing Frequency: All soil property requirements shall be tested during initial source evaluation or if a change in source is requested. Lightweight aggregate material shall be sampled once every 2,000 cubic yards and tested for gradation and pH. Lightweight aggregate material shall be sampled once every 5,000 cubic yards and tested for internal friction angle, organic content, resistivity, chloride content, and sulfate content. Chloride and sulfate content testing will not be required if resistivity test results indicate 5000 ohm-cm or greater. The internal friction angle shall be tested every 2,000 cubic yards if the gradation indicates that the coefficient of uniformity, C_u , is less than 4. A variation in testing frequency may be required if a variation in material gradation or composition is observed.

5.0 Measurement and Payment. Measurement of lightweight aggregate shall be the actual volume in-place at the project site. All costs for furnishing, loading, hauling, placing and compacting lightweight aggregates (either man-made or natural) shall be included in the unit price of the lightweight aggregates.

Payment will be made under:

Item No.	Pay Item	Pay Unit
2033020	Borrow Excavation (Lightweight)	CY

(75) DIVISION 200: HIGH-STRENGTH GEOTEXTILE FOR EMBANKMENT REINFORCEMENT

June 17, 2010

1.0 DESCRIPTION

This work shall consist of furnishing and installing construction geotextiles in accordance with the details shown in the plans, specifications, or as directed by the RCE.

2.0 MATERIALS

A geotextile is defined as any permeable polymeric textile used with foundation, soil, rock, earth, or any other geotechnical engineering related material, as an integral part of a civil engineering project, structure, or system. Use geotextiles and thread used in joining geotextiles manufactured from fibers consisting of long-chain polymers, composed of at least 95 percent by weight of polyolefins or polyesters. Use geotextiles with fibers formed into a stable network such that the fibers or yarns retain their dimensional stability relative to each other, including selvages (edges) during shipping, handling, placement, and in service. Use geotextile free from defects or tears.

- E. **Minimum Average Roll Values:** All property values, with the exception of Apparent Opening Size (AOS), represent Minimum Average Roll Values (MARV) in the weakest principal direction. Provide geotextiles whose average test results from any roll sampled in a lot for conformance or quality assurance testing meets or exceeds minimum values provided in this Section.
- F. **Apparent Opening Size:** Values for Apparent Opening Size (AOS) represent maximum average roll values. Acceptance will be based on ASTM D 4759.
- G. **Reinforcement Geotextile:** Use reinforcement geotextile within existing and/or proposed fills for slope reinforcement.

Furnish geotextiles meeting the property requirements outlined in Table 1.

Table 1: High Strength Geotextile Properties (Design Requirements)^{1,2}

Property	Test Method	Geotextile Property Requirements
----------	-------------	----------------------------------

EXHIBIT 5 - SPECIAL PROVISIONS

Long-Term Design Strength, T_{al} , MD		22,800 lb/ft
Long-Term Design Strength, T_{aj} , XD		2,280 lb/ft
Sewn Seam Breaking Strength ³	ASTM D4884	900 lbs/ft
AOS	ASTM D4751	$\leq(1.0 \text{ to } 2.0)D_{85(\text{soil})}$
Permeability	ASTM D4491	$\geq 10k_{\text{soil}}$
Default Pullout Friction Factor, F^*	ASTM D6706	$0.6 \tan \Phi$
Default Alpha, α	ASTM D6706	0.6
Ultraviolet Stability	ASTM D4355	$\geq 50\%$ after 500 hrs of exposure

- Notes:
1. The test procedures shall conform to the most recently approved ATSM geotextile test procedures.
 2. All numeric values represent Minimum Average Roll Value (MARV).
 3. Applies to factory or field sewn seams.

2.1 Source Approval and Certification. Prior to construction, the Contractor shall submit to the Resident Construction Engineer (RCE) a Certification Package prepared by the geotextile reinforcement manufacturer. The Contractor shall allow 21 calendar days from the day the submittals are received by the RCE for review and acceptance. Submit the following information regarding each geotextile proposed for use:

- Manufacturer's name and current address;
- Full product name/number, including roll number;
- Geosynthetic material (i.e. polymer type) and structure (including fiber/yarn type);
- Proposed geotextile use(s); and
- Certified test results for the properties outlined in Table 1 and below in Section 2.

The Certification shall state that the furnished geotextile soil reinforcement is in full compliance with the design requirements as stated in this specification and the design drawings and is fit for use in long-term critical soil reinforcement applications. In addition to the minimum required properties in Table 1, the submittal shall also certify the following values for each geotextile soil reinforcement used on the project:

4. The ultimate tensile strength, T_{ULT} , (MARV) for geogrid soil reinforcements, MD/XD
5. The tensile strength at 5% strain, MD
6. The creep reduced tensile strength, MD
7. The geotextile's pullout coefficients (F^* , α)

The Contractor's submittal package shall include, but not be limited to, actual test results for tension, creep, durability, construction damage, joint/seam strength, pullout and quality control. A person having the legal authority to bond the manufacturer shall attest to the certificate. Any tests required shall be performed at no additional cost to the Department. If in the opinion of the RCE, the required documentation is not provided for individual reduction factors (RF) or pullout coefficients (F^* , α), default values for these design parameters shall be used in accordance with this specification.

2.1.1 Ultimate Tensile Strength (T_{ult}): The ultimate tensile strength, T_{ult} , shall be determined from wide width tensile tests (ASTM D 4595). Geotextile samples tested in accordance with ASTM D 4595 shall be with an 8-inch width specimen, or a 4-inch specimen width with correlation to an 8-inch width. Correlation methodology shall be submitted to, and is subject to acceptance by the RCE. All geotextile strength tests (ASTM D 4595 and ASTM D 6637) shall be conducted at a strain rate of 10% per minute based on actual gage length necessary to meet the testing sample dimension requirements. Laboratory test results documenting the ultimate tensile strength, T_{ult} , in the reinforcement direction shall be based on the minimum average roll values (MARV) for the product.

2.1.2 Long-Term (Allowable) Design Tensile Strength (T_{al}): The allowable tensile load per unit width of geotextile soil reinforcement, T_{al} , in accordance to the backfill type used shall be computed as follows:

$$T_{al} = \frac{T_{ult}}{RF}$$

EXHIBIT 5 - SPECIAL PROVISIONS

2.1.3 Reduction Factor (RF): The total reduction factor, RF, is the combined reduction factor for long-term degradation due to installation damage, creep, and durability. The total reduction factor, RF, shall be defined as follows:

$$RF = RF_{ID} \times RF_{CR} \times RF_D \geq 3.0$$

The individual reduction factors shall be documented in accordance with the site conditions, design calculations, and specifications. When sufficient documentation is not provided for individual reduction factors, RF_{ID} , RF_{CR} , and RF_D , a reduction factor RF of 7.0 shall be used. The reinforcement manufacturer shall certify and document the individual reduction factors as follows:

2.1.4 Installation Damage Reduction Factor (RF_{ID}): The reduction factor for installation damage, RF_{ID} , shall be documented by field and laboratory test results and literature review, as described in ASTM D 5818 for the reinforced backfill specified or for more severe soils. Samples subjected to installation damage shall be tested for tensile strength and deformation characteristics in accordance with ASTM D 4595. Recommended values for reduction factors for installation damage (RF_{ID}) for various soils shall also be documented. The minimum installation damage reduction factor, RF_{ID} , shall be 1.1, regardless of product specific test results.

2.1.5 Creep Reduction Factor (RF_{CR}): Laboratory test results documenting creep performance over a range of load levels, for a minimum duration of 10,000 hours based on tension creep test (ASTM D 5262) shall be required. Creep test samples shall be of sufficient width to be representative of overall product creep response (fiber creep testing will not be accepted).

The creep-limiting strength, T_i , shall be based on extrapolating the 10,000 hours (or longer duration) tension creep tests to a 75-year design life, unless a 100-year design life is specified in the plans. The creep extrapolation method shall be based on methods described in FHWA NHI-10-025, "Design and Construction of Mechanically Stabilized Earth Walls and Reinforced Soil Slopes" - Appendix "D". Laboratory test results and extrapolation methodology shall be documented.

The reduction factor for creep, RF_{CR} , is defined as the ratio of the average lot specific ultimate tensile strength, T_{ULTLOT} , to the creep-limiting strength, T_i . The average lot specific ultimate tensile strength, T_{ULTLOT} , for the lot of material used for creep testing, T_{ULTLOT} , shall be determined from wide width tensile test, ASTM D 4595.

2.1.6 Durability Reduction Factor (RF_D): The total reduction factor for durability, RF_D , shall be defined as the combined effects of chemical and biological degradation. Laboratory test results, extrapolation techniques, and a comprehensive literature review shall document the reduction factor for durability for all material components in accordance with FHWA NHI-09-087, "Corrosion/Degradation of Soil Reinforcements for Mechanically Stabilized Earth Walls and Reinforced Soil Slopes". The minimum durability reduction factor, RF_D , shall be 1.1, regardless of product specific test results.

2.1.7 Soil Reinforcement Pullout Coefficients (F^* , α): The Certification Package shall document the pullout coefficients (F^* , α) meet or exceed the required coefficients necessary to obtain the T_{ai} provided above where,

$$F^* = \text{Minimum pullout friction factor} = C_i \tan \Phi,$$

C_i = soil interaction coefficient ≥ 0.6
 Φ = Soil Angle of Internal Friction

The pullout friction factor, F^* , and the scale effect correction factor, α , shall be documented by laboratory testing from pullout tests. Pullout testing shall be conducted for site-specific materials or for materials representative of the reinforced backfill at confining pressures ranging from 2 to 10 psi. When laboratory tests are used from representative soils, the representative soils shall be documented by providing the soil's angle of internal friction, gradation, and coefficient of uniformity ($C_u = D_{60}/D_{10}$).

EXHIBIT 5 - SPECIAL PROVISIONS

Recommended pullout coefficients for various soil types shall also be documented. The pullout coefficients shall be determined by using the quick effective stress pullout tests ("Measuring Geosynthetic Pullout Resistance in Soil" per ASTM D 6706). The soil interaction coefficient, C_i , shall be documented when computing the pullout friction factor, F^* . When sufficient documentation is not provided for pullout coefficients, F^* and α , and the coefficient of uniformity, C_u , is greater or equal to 4, the default values indicated in this specification can be used. If the coefficient of uniformity of the reinforced backfill is less than 4, laboratory pullout test shall be required to determine pullout friction factor, F^* , and the default scale effect factor, α .

2.2 Sample Approval. To confirm that the on-site geotextile meets the property values specified, random samples shall be submitted to the RCE for evaluation. The machine direction shall be marked clearly on each sample submitted for evaluation. The machine direction is defined as the direction perpendicular to the axis of the roll.

Cut a sample from the geotextile roll with the minimum dimensions of 4 feet by the full width of the roll beyond the first wrap. The geotextile samples shall be cut from the roll with scissors, sharp knife, or other suitable method that produces a smooth edge and does not cause geotextile ripping or tearing. Submit a manufacturer's certificate of compliance signed by an authorized manufacturer's official. The certificate must attest that the geotextile meets all the Minimum Average Roll Value (MARV) requirements specified in Table 1 as evaluated under the manufacturer's quality control program. Geotextiles supplied for construction of the project shall be certified in accordance with the following criteria. The tests described in the specification shall be conducted by the manufacturer or by an approved independent testing laboratory on samples taken from the same lot number as the material actually shipped to the project and at the specified frequency. The manufacturer or independent testing laboratory shall maintain the appropriate accreditations and must be preapproved by the Department. All rolls shall be marked with individual and distinct roll numbers. All roll numbers shall have traceable certified mill test reports from the given lot that they were manufactured. These test reports must be supplied to the Department prior to installation of any geotextile materials. After the sample and the required information have been submitted to the RCE, allow 30 calendar days for evaluation.

Product acceptance is determined by comparing the average test results of all specimens within a given sample to the Minimum Average Roll Values (MARV) listed in Table 1. Install geotextiles only after the material has been tested and/or evaluated and accepted. Replace all geotextiles installed prior to acceptance that do not meet specifications at Contractor's expense.

2.2.1 Sewn Seam Approval. If the geotextile seams are to be sewn in the field, the Contractor shall provide a section of sewn seam that can be sampled by the RCE before the geotextile is installed. The sewn seam shall be in accordance with ASTM 6193.

The seam sewn for sampling shall be sewn using the same equipment and procedures as will be used to sew the production seams. The seam sewn for sampling must be at least 6 feet in length. If the seams are sewn in the factory, the Contractor shall provide samples of the factory seam at random from any of the rolls to be used. Regardless of whether the seam is to be sewn in the factory or the field, the manufacturer and/or Contractor shall certify that the strength meets the requirement set forth in Table 1. If seams are to be sewn in both the machine and cross-machine direction, provide samples of seams from both directions. The seam assembly description shall be submitted by the Contractor to the Engineer and will be included with the seam sample obtained for testing. This description shall include the seam type, stitch type, sewing thread type(s), and stitch density.

If sewn seams are used for seaming the geotextile, use thread that consists of high strength polypropylene or polyester. Do not use nylon thread. Use thread that is of contrasting color to that of the geotextile itself.

If the manufacturer can provide a T_{al} MD that is greater than the sum of the required T_{al} MD and sewn seam breaking strength (for each specified in the project plans), the sewn seams may be eliminated and a minimum overlap of 1 foot may be used.

2.3 Identification, Shipment and Storage. Conform to ASTM D 4873, *Standard Guide for Identification, Storage, and Handling of Geotextiles*. Clearly label each roll of geotextile shipped to the project with the name and address of the manufacturer, full product name/number, quantity, and roll number.

The RCE will reject materials that are mislabeled or misrepresented. Wrap each roll with a material that protects the geotextile, including ends of the roll, from damage due to shipment, water, sunlight, and contaminants. Maintain the protective wrapping during periods of shipment and storage. Do not damage the geotextile or wrapping when unloading or transferring from one location to another. Do not drag the rolls.

During storage, elevate geotextile rolls off the ground and adequately cover to protect them from the following:

- Site construction damage;
- Precipitation;
- Ultraviolet radiation including sunlight;
- Chemicals that are strong acids or strong bases;
- Flames including welding sparks, temperatures in excess of 140 °F (60 °C); and
- Mud, dirt, dust, debris and any other environmental condition that may damage the physical property values of the geotextile.

3.0 CONSTRUCTION REQUIREMENTS

3.1 General. Prepare the surface on which the geotextile is to be placed so that no damage occurs to the geotextile. Do not drive or operate any construction equipment on the geotextile. Dispose of material with defects, rips, holes, flaws, deterioration, or other damage. Do not use defective material in the work. The manufacturer shall be present on site for a minimum of two days of geotextile installation such that the manufacturer observes any field-sewn seams.

3.2 Installation Plan. Within thirty (30) calendar days after award of the contract or no later than thirty (30) calendar days before beginning high-strength geotextile installation, the Contractor shall submit to the Department for review a high-strength geotextile installation plan that includes as a minimum the following information:

- a) The Contractor shall certify and provide proof to the Department of experience in the work described. The Contractor shall have successfully installed at least 500,000 square yards of any geotextile that has sewn seams during the last five years. In addition, the Contractor shall have successfully completed at least five projects within the last five years of similar size and complexity to that of the Project.

The Contractor's experience shall be documented by providing a project summary that includes for each referenced project, the project start and completion dates, total quantity of geotextile installed (specifically indicate if high-strength geotextile installed), and a detailed description of the project, site conditions, and subsurface conditions. The project description shall include details of the geotextile materials, the equipment and technique used to install the geotextiles, the average and maximum area of geotextile installed, the client name and address, the name and telephone number of the representative of the consultant and owner for whom the work was performed and who can attest to the successful completion of the work, and any other information relevant to demonstrating the Contractor's qualifications.

- b) Resume of supervisor documenting experience and qualifications in the installation of both normal and high-strength geotextile. The Contractor shall have a full-time supervisor who has been in responsible charge of supervising geotextile installation operations for at least five projects in the last five years. The supervisor shall be present at the work site at all times during installation operations. The acceptability of the supervisor, as well as any replacement for the supervisor, will be subject to the approval of the Department.

EXHIBIT 5 - SPECIAL PROVISIONS

- c) Shop drawings showing the planned locations and elevations of all high-strength geotextiles. The installation sequence shall also be provided including any required staging. The shop drawings shall also show the location of the bridge abutment, and the limits of the final embankment and construction staging.
- d) Detailed description of proposed installation procedures.
- e) Proposed methods and equipment for sewn seams.

3.3 Site Preparation. Prepare the installation site by clearing, grubbing, and excavating or filling the area to the design grade. This includes removal of topsoil or vegetation. The RCE will identify soft spots and unsuitable areas during site preparation. This may include but not be limited to proof-rolling specific areas defined by the RCE. Excavate these areas and backfill with approved borrow or bridge lift material and compact as specified. The area to be covered by the geotextile shall be graded to a smooth, uniform condition free from ruts, potholes, and protruding objects such as rocks or sticks.

The Contractor may construct a working platform, up to 2 feet in thickness, in lieu of grading the existing ground surface. A working platform is required where stumps or other protruding objects which cannot be removed without excessively disturbing the subgrade are present. These areas shall be prepared in accordance with the 2007 Standard Specifications for Highway Construction. The stumps shall be covered with at least 6 inches of fill before placement of the first geotextile layer.

3.4 Geotextile Placement. The geotextile shall be spread immediately ahead of the covering operation. The geotextile shall be laid with the machine direction perpendicular or parallel to centerline as shown in Plans. All seams shall be sewn. Seams to connect the geotextile strips end to end will not be allowed. The geotextile shall not be left exposed to sunlight during installation for a total of more than 14 calendar days. The geotextile shall be laid smooth without excessive wrinkles. Under no circumstances shall the geotextile be dragged through mud or over sharp objects, which could damage the geotextile.

Small soil piles or the manufacturer's recommended method shall be used as needed to hold the geotextile in place until the specified cover material is placed. Remove wrinkles and folds by pulling the geotextile taut as required.

Should the geotextile be torn or punctured or the sewn joints disturbed, as evidenced by visible geotextile damage, subgrade pumping, intrusion, or roadbed distortion, the backfill around the damaged or displaced area shall be removed and the damaged area repaired or replaced by the Contractor at no expense to the Department. The repair shall consist of a patch of the same type of geotextile placed over the damaged area. The patch shall be sewn at all edges.

If geotextile seams are to be sewn in the field or at the factory, the seams shall consist of two parallel rows of stitching, or shall consist of a J-seam, Type SSn-2. The two rows of stitching shall be 1 inch apart with a tolerance of plus or minus 0.5 inches and shall not cross, except for restitching. The stitching shall be a lock-type stitch. The minimum seam allowance, i.e., the minimum distance from the geotextile edge to the stitch line nearest to that edge, shall be 1.5 inches if a flat or prayer seam, Type SSa-2, is used. The minimum seam allowance for all other seam types shall be 1 inches. The seam, stitch type, and the equipment used to perform the stitching shall be as recommended by the manufacturer of the geotextile and as approved by the RCE.

The seams shall be sewn in such a manner that the seam can be inspected readily by the RCE or his representative. The seam strength will be tested and shall meet the requirements stated herein.

3.5 Fill Placement. Embankment construction shall be kept symmetrical at all times to prevent localized bearing capacity failures beneath the embankment or lateral tipping or sliding of the embankment. Place fill over the geotextile by dumping onto previously placed material and pushing the material into place. Stockpiling of fill on the geotextile will not be allowed.

EXHIBIT 5 - SPECIAL PROVISIONS

The cover material shall be placed on the geotextile in such a manner that a minimum of 8 inches of uncompacted material will be between the equipment tires or tracks and the geotextile at all times. Construction vehicles shall be limited in size and weight such that rutting in the initial lift above the geotextile is not greater than 3 inches deep, to prevent overstressing the geotextile. Do not blade material down to remove ruts. Fill any ruts or depressions with additional material and compact to the specified density. Turning of vehicles on the first lift above the geotextile will not be permitted. If the geotextile is being placed on soft ground, compaction of the first lift above the geotextile shall be limited to routing of placement and spreading equipment only. If groundwater is present within 2 feet of the any lift, vibratory compaction shall not be used. If the subgrade is very soft with an undrained shear strength less than 500 psf minimize pile heights to less than 3 feet and spread piles as soon as possible after dumping to minimize the potential for localized subgrade failure due to overloading of the subgrade.

A sandy material that meets the requirements of an A-2 AASHTO soil classification shall be the only borrow excavation soil allowed for placement between the lowest elevation geotextile and the bottom of the pavement section. The embankment fill soils shall be compacted in accordance with the 2007 Standard Specifications for Highway Construction. Fill shall be placed in 12-inch maximum lift thicknesses where heavy compaction equipment is to be used and 6-inch maximum uncompacted lift thicknesses where hand-operated equipment is used.

The geotextile shall be pretensioned during installation using either Method 1 or Method 2 as described herein. The method selected will depend on whether or not a mudwave forms during placement of the first one or two lifts. If a mudwave forms as fill is pushed onto the first layer of geotextile, Method 1 shall be used. Method 1 shall continue to be used until the mudwave ceases to form as fill is placed and spread. Once mudwave formation ceased, Method 2 shall be used until the uppermost geotextile layer is covered with a minimum of 1 foot of compacted fill. These special construction methods are not needed for fill construction above this level. If a mudwave does not form as fill is pushed onto the first layer of geotextile, then Method 2 shall be used initially and until the uppermost geotextile layer is covered with at least 1 foot of compacted fill.

Method 1

After the working platform, if needed, has been constructed, the first layer of geotextile shall be laid as outlined in the project plans and the joints sewn together. The geotextile shall be stretched manually to ensure that no wrinkles are present in the geotextile. The fill shall be end-dumped and spread from the edge of the geotextile. The fill shall first be placed along the outside edges of the geotextile to form access roads. These access roads will serve three purposes: to lock the edges of the geotextile to form access roads, to contain the mudwave, and to provide access as needed to place fill in the center of the embankment. These access roads shall be approximately 16 feet wide. The access roads at the edges of the geotextile shall have a minimum height of 2 feet completed. Once the access roads are approximately 50 feet in length, fill shall be kept ahead of the filling operation, and the access roads shall be kept approximately 50 feet ahead of this filling operation. Keeping the mudwave ahead of this filling operation and keeping the edges of the geotextile from moving by use of the access roads will effectively pre-tension the geotextile. The geotextile shall be laid out no more than 20 feet ahead of the end of the access roads at any time to prevent overstressing of the geotextile seams.

Method 2

After the working platform, if needed, has been constructed, the first layer of geotextile shall be laid and sewn as in Method 1. The first lift of material shall be spread from the edge of the geotextile, keeping the center of the advancing fill lift ahead of the outside edges of the lift. The geotextile shall be manually pulled taut prior to fill placement. Embankment construction shall continue in this manner for subsequent lifts until the uppermost geotextile layer is completely covered with 1 foot of compacted fill.

4.0 METHOD OF MEASUREMENT

EXHIBIT 5 - SPECIAL PROVISIONS

Measurement of geotextile is on a square yard basis and will be computed based on the total area of geotextile shown in the plans, exclusive of the area of geotextiles used in any overlaps, seams, and/or joints. This shall include all costs associated with installation of the geotextile. Overlaps and any geotextile waste are an incidental item.

5.0 BASIS OF PAYMENT

Payment at the contract unit price is full compensation for all resources necessary to complete the item of work under the contract. Payment for the completed and accepted quantities is made under the following:

Item No.	Pay Item	Unit
2037110	GEOTEX REINF.	SY

(76) SECTION 203: MUCK EXCAVATION

September 19, 2011

Section 203.2.1.3 is amended as follows:

Any areas identified on the plans and any additional areas defined by the RCE that are discovered to deflect or settle may require corrective action by the Contractor. This may include undercutting, placing granular aggregate, placing stone aggregate that is separated from other fine aggregate materials by a geotextile for separation of sub-grade and sub-base, and/or additional compacting to the approval of the Engineer.

In areas that require mucking or undercutting, borrow excavation soil may be placed as a bridge lift as long as the grade on which the material is being placed is at least 2 feet above ground water level. In the event that groundwater does not allow backfilling with a borrow excavation soil, a stone or granular material shall be used as the bridge lift material. This stone or granular material shall be in accordance with the Bridge Lift Materials Special Provision. Stone bridge lift materials shall have a thickness of 2 feet and shall extend a minimum of 6 inches above the ground/surface water level. Granular lift materials shall also have a thickness of 2 feet, but shall extend a minimum of 2 feet above ground/surface water level. Individual granular bridge lifts shall not exceed a 2-foot thickness without some type of limited compactive/tamping effort. The depth at which mucking or undercutting shall take place is dependent upon encountering a suitable bearing material within the excavation or a predetermined elevation or depth. In most cases, undercutting shall not exceed 3 to 5 feet in depth, but the final mucking or undercutting thickness shall be based on the decision of the RCE, unless otherwise specified in the project plans and/or specifications. If a suitable bearing soil is not encountered within this depth range or unless otherwise specified in the plans and/or specifications, a P1 biaxial geogrid with an aperture size of less than or equal to 1 inch shall be placed beneath the stone or granular bridge lift material. The geogrid shall be placed in the bottom of the excavation and up the excavation side slopes. If additional compacted borrow excavation soil is needed to reach grade, a geotextile for separation of sub-grade and sub-base shall be placed between any stone bridge lift material and the overlying compacted soil. A

EXHIBIT 5 - SPECIAL PROVISIONS

bridge lift consisting of borrow excavation soil or granular bridge lift material should not be placed within 3 feet of the base of the pavement section. Only compacted borrow excavation soil or stone bridge lift material shall be placed within this zone. The biaxial geogrid shall be in accordance with the Special Provision provided in the project documents.

The quantities associated with mucking and undercutting, i.e. mucking, stone and granular bridge lift materials, geogrid, and geotextile for separation of sub-grade and sub-base, are for bid estimation purposes only. These bid items shall not be purchased and stockpiled on site without written approval from the RCE unless specific areas and details are defined in the plans.

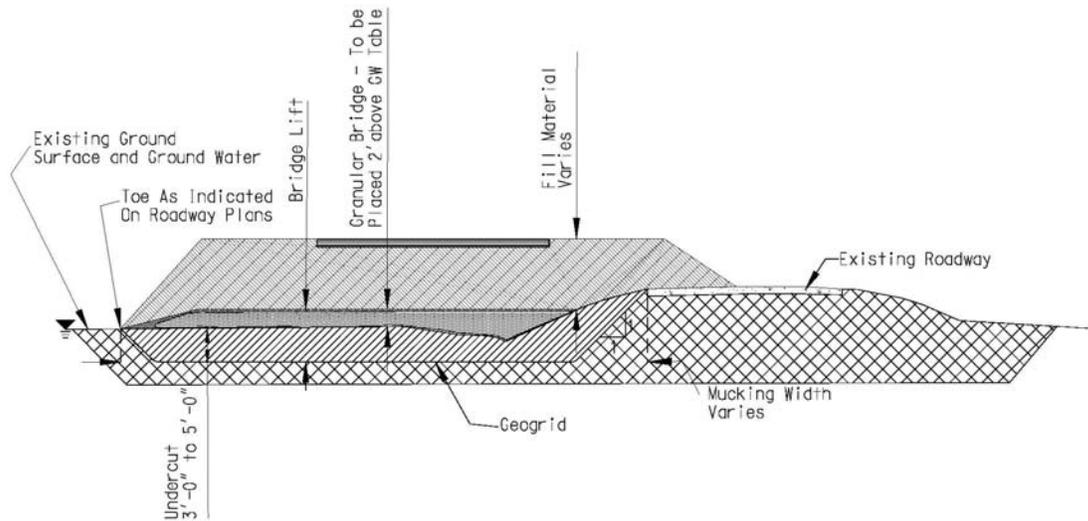

UNDERCUT, GEOGRID, AND GRANULAR BRIDGE LIFT

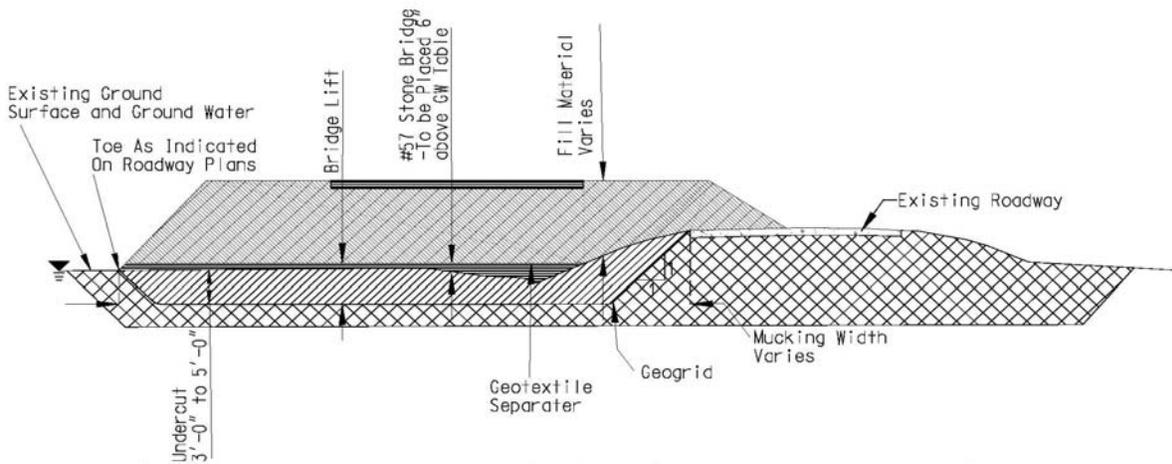

UNDERCUT, GEOGRID, AND STONE BRIDGE LIFT

(77) DIVISION 200: PREFABRICATED EARTHQUAKE DRAIN WITH FILTER FABRIC

January 24, 2012

Division 200 is expanded as follows:

1.0 DESCRIPTION OF WORK

This work shall consist of furnishing all necessary submittals, materials, labor, equipment, and incidentals for the installation of prefabricated earthquake drains in accordance with the details shown on the plans and the requirements of the Supplemental Specifications. The earthquake drains shall consist of a corrugated pipe with slot type perforations enclosed by a geotextile filter fabric. Space within the pipes above the ground water table provides a reservoir for water expelled from the ground for liquefaction prevention. If required, additional reservoir space shall be constructed in accordance with details shown on the project drawings. The earthquake drains shall be installed at locations shown on the plans, unless otherwise directed by the Engineer. The earthquake drains shall be installed to full length without splicing. If splicing is required the Contractor shall contact the Department for instruction and additional requirements.

2.0 QUALITY ASSURANCE

2.1 Standards: American Society for Testing and Material (ASTM)

ASTM D3776 Standard Test Method for Measuring Mass per Unit Area of Geotextiles

ASTM D3786 Standard Test Method for Hydraulic Bursting Strength of Textile Fabrics – Diaphragm Bursting Strength Tester Method

ASTM D4491 Standard Test Method for Water Permeability of Geotextiles by Permittivity

ASTM D4533 Standard Test Method for Trapezoid Tearing Strength of Geotextiles

ASTM D4632 Standard Test Method for Grab Breaking Load and Elongation of Geotextiles

ASTM D4833 Standard Test Method for Index Puncture Resistance of Geotextiles, Geomembranes, and Related Products

2.2 Quality Control: The earthquake drains shall be installed with equipment that will maintain the mandrel in a vertical position. The Contractor shall consider the subsoils at the site when selecting equipment and developing the earthquake drain installation plan. The equipment shall generate sufficient pressure necessary to install the earthquake drains through all existing subsurface material to the depths shown on the plans. The equipment shall have the capability of installing the earthquake drains to a depth of not less than 10 feet greater than the maximum earthquake drain depth shown on the plans.

Approval of the sample earthquake drain material by the Engineer will be required prior to delivery of the earthquake drain material to the Project. The earthquake drain manufacturer shall be a specialist in the manufacture of earthquake drains, and shall have produced a minimum of 1,000,000 linear feet of the earthquake drain material proposed for the Project, that have been used in successful applications within the past five years.

The earthquake drains shall be free of defects, rips, holes, and/or flaws. During shipment and storage, the earthquake drains shall be wrapped in a protective covering. The earthquake drains shall be protected from sunlight, mud, dirt, dust, debris, and detrimental substances during shipping and on-site storage.

The Contractor shall certify and provide proof to the Department of experience in the work described. The Contractor shall have successfully installed at least 2,000,000 linear feet of earthquake drains during the last five years. In addition, the Contractor shall have successfully completed at least five projects within the last five years of similar size and complexity to that of the Project.

The Contractor's experience shall be documented by providing a project summary that includes for each referenced project, the project start and completion dates, total quantity of earthquake drains installed, and a detailed description of the project, site conditions, and subsurface conditions. The project description shall include details of the earthquake drain materials, the equipment and technique used to

EXHIBIT 5 - SPECIAL PROVISIONS

install the earthquake drains, the average and maximum length of earthquake drain installed, the client name and address, the name and telephone number of the representative of the consultant and owner for whom the work was performed and who can attest to the successful completion of the work, and any other information relevant to demonstrating the Contractor's qualifications.

The Contractor shall have a full-time supervisor who has been in responsible charge of supervising earthquake drain installation operations for at least five projects in the last five years. The supervisor shall be present at the work site at all times during earthquake drain installation operations. The acceptability of the supervisor, as well as any replacement for the supervisor, will be subject to the approval of the Department.

3.0 SUBMITTALS

3.1 Prefabricated Earthquake Drain Installation Plan: Within thirty (30) calendar days after award of the contract or no later than thirty (30) calendar days before beginning earthquake drain installation, the Contractor shall submit to the Department for review an earthquake drain installation plan that includes as a minimum the following information:

- a) Size, type, weight, maximum pushing force, vibratory-hammer rated energy, and configuration of the installation rig.
- b) Dimensions and length of the mandrel.
- c) Details of earthquake drain anchorage.
- d) Detailed description of proposed installation procedures.
- e) Proposed methods and equipment for pre-augering.
- f) Documentation of the successful application of the proposed earthquake drain installation operations.
- g) Method of measuring the installed length of the earthquake drain.
- h) Shop drawings showing the planned locations and bottom elevations of all earthquake drains and showing a unique identification number for each earthquake drain. The installation sequence shall also be provided. The shop drawings shall also show the location of the bridge abutment, and the limits of the final embankment and construction staging.
- i) Resume of supervisor documenting experience and qualifications in the installation of earthquake drains.

3.2 Prefabricated Earthquake Drain Material: At least thirty (30) calendar days before beginning earthquake drain installation, the Contractor shall:

- a) Submit to the Department for testing three samples of the earthquake drain to be used, with the accompanying manufacturer specifications for the earthquake drain material. The samples of the earthquake drain shall be at least five feet long. The samples shall be stamped or labeled by the manufacturer as being representative of the earthquake drain material having its specified trade name.
- b) Submit to the Department three samples of the proposed anchor plate to be used to anchor the earthquake drains at the design depth shown on the plans.
- c) Submit to the Department manufacturer's literature documenting the physical and mechanical properties of the earthquake drain components. Submit to the Department a manufacturer's list of other similar projects where the same drain has been installed, including details on prior performance on these projects.

EXHIBIT 5 - SPECIAL PROVISIONS

- d) The Contractor shall identify the proposed source of the materials prior to delivery to the site. The Contractor shall supply a manufacturer's material certification that the earthquake drain with filter fabric meets or exceeds the material requirements of this Special Provision.

3.3 Submittal Reviews: All submittals to the Department shall be reviewed according to Section 725 of the SCDOT Standard Specifications for Highway Construction. The submittals shall be reviewed and accepted or rejected within twenty-one (21) calendar days of receipt by the Department. Acceptance of the proposed materials, equipment, construction sequence, and method by the Department shall not relieve the Contractor of its responsibility to install the earthquake drains in accordance with the plans and Special Provision. Approval by the Department of the method and equipment to be used to install the earthquake drains shall be contingent upon satisfactory demonstration of earthquake drain installation at the project site. If, at any time, the Department or the Engineer considers that the method of installation does not produce satisfactory earthquake drains, the Contractor shall alter the method and/or equipment as necessary to comply with the Special Provision. The Department will be the sole judge in determining the adequacy of the Contractor's methods and equipment.

3.4 As-Built Plans: The Contractor shall provide the Department with "as-built" plans of the earthquake drain installation. Such plans shall include the locations of the earthquake drains, the date the drains were installed, , the surface elevation at the drain installation, the "as-built" vertical drain tip elevation, and shall identify any rejected or abandoned drain installations. "As-built" plans shall be submitted at least weekly during earthquake drain installation operations. A final "as-built" plan shall be submitted within seven calendar days of the completion of earthquake drain installation in all embankment locations. The final "as-built" plans will be subject to the approval of the Department.

4.0 MATERIALS

4.1 The earthquake drains shall consist of newly manufactured materials and shall consist of an annular-corrugated interior and exterior plastic drainage core wrapped in a non-woven geotextile filter fabric. The filter fabric shall allow free passage of pore water to the core without loss of soil material or piping. The core shall provide drainage through slot type perforations and a reservoir in the space above the ground water table. Optional, additional reservoir space may take the form of a naturally occurring permeable soil layer if such layer is present. In other cases an artificial reservoir may need to be provided. This artificial reservoir may take any of several forms, ranging from a layer of open graded stone applied over the area, to individually constructed reservoirs at each drain as specified in the plans. The prefabricated earthquake drain material shall meet the following specifications:

Nominal Inside Diameter	As indicated on the plans
Minimum Pipe Stiffness @ 5% Deflection:	35psi
Minimum Drainage Slot Area:	0.013 ft ² /ft
Minimum Water Permeability, fabric: (ASTM D4491)	0.01 in/sec (K-value)
Minimum Water Permittivity, fabric: (ASTM D4491)	0.1 sec ⁻¹
Minimum Tear Strength, fabric: (ASTM D4533)	50 lb
Minimum Tensile Strength, fabric: (ASTM 4632)	90 lb
Minimum Elongation at break: (ASTM D4632)	60 percent
Minimum Puncture Strength, fabric: (ASTM 4833)	35 lb
Minimum Mullen Burst, fabric:	150 psi

EXHIBIT 5 - SPECIAL PROVISIONS

(ASTM D3786)

4.2 The filter fabric and core components shall conform to the following:

- a) The filter fabric shall be synthetic non-woven geotextile capable of resisting bending, punching and tensile forces imposed during installation and during the design life of the earthquake drain.
- b) The filter fabric shall not be subject to localized damage (e.g., punching through the filter by sand/gravel particles).
- c) The filter fabric shall be rigid enough to withstand lateral earth pressures due to embedment and surcharge so that the vertical flow capacity through the core will not be adversely affected.
- d) The filter fabric shall be flexible enough to bend smoothly during installation and induced densification without damage.
- e) The filter fabric shall not undergo cracking and peeling during installation of the earthquake drain.
- f) The core shall have an annular-corrugated interior and exterior. The assembled earthquake drain shall be resistant against wet rot, mildew, bacterial action, insects, salts in solution in the ground water, acids, alkalis, solvents, and other ingredients in the site ground water.

4.3 Earthquake drain materials shall be labeled or tagged in such a manner that the information for sample identification and other quality control purposes can be read from the label. As a minimum, each roll shall be identified by the manufacturer as to lot or control numbers, individual roll number, date of manufacture, manufacturer and product identification of the filter fabric and core.

During shipment and storage, the earthquake drain shall be wrapped in burlap or similar heavy duty protective covering. The earthquake drain shall be protected from sunlight, mud, dirt, dust, debris, and other detrimental substances during shipping and on-site storage.

Material which is damaged during shipment, unloading, storage, or handling, or which does not meet the requirements of the earthquake drain material will be rejected by the Department. No payment will be made for rejected material.

5.0 INSTALLATION

5.1 Earthquake drains shall be installed as indicated on the plans or as directed by the Department. Earthquake drains shall be spaced as indicated on the plans. Earthquake drains shall be installed in stages coinciding with construction stages. Earthquake drains shall be installed using a mandrel or a sleeve that shall advance through the soils to the elevations shown on the plans. The earthquake drains shall be installed using equipment that will maintain the mandrel in a vertical position. The mandrel or sleeve shall protect the drain material from tears, cuts, and abrasion during installation and shall be retracted after each earthquake drain is installed. The mandrel shall be fitted with three symmetrically spaced fins for transmitting vibrations to the soil during installation.

5.2 The installation rig shall utilize a vibrator with an eccentric moment sufficient to generate vertical vibration to the mandrel during installation. The equipment shall also generate sufficient vertical force (static crowd) to the mandrel to install the earthquake drains through all existing subsurface materials to the depths shown on the plans.

5.3 The earthquake drain shall be provided with an "anchor" plate or similar arrangement to anchor the bottom of the drain at the required depth during mandrel removal and to prevent soil from entering the bottom of the mandrel during drain installation. The anchorage shall be adequate to keep the bottom of the earthquake drain at the required depth subject to approval and field verification by the Department.

EXHIBIT 5 - SPECIAL PROVISIONS

The corresponding dimension of the anchor shall conform as closely as possible to the breadth dimensions of the mandrel to minimize soil disturbance.

5.4 The Contractor shall notify the Department at least 24 hours prior to installation of the initial earthquake drains, to allow the Department sufficient time to provide the necessary inspection for the initial earthquake drain installation. Installation of the initial earthquake drains shall not proceed without the presence of the Department's inspector. During the installation of the initial ten earthquake drains, the Contractor shall demonstrate that the equipment, method, and material produce a satisfactory installation, as determined by the Department. Following completion of the initial earthquake drain installations, the Contractor shall not proceed with the installation of the remaining earthquake drains until authorized by the Department.

5.5 If foundations have been previously installed, the prefabricated earthquake drains shall be installed in a manner as to avoid foundation piles or spread footings. The location of the earthquake drains relative to the foundations shall be determined and staked out prior to the installation of the prefabricated earthquake drains. In addition, the Contractor shall be responsible for taking precautions to preserve the stake locations and is responsible for re-staking, if necessary.

5.6 Earthquake drains shall be located, numbered, and staked out using a baseline and benchmark provided by the Contractor. The Contractor shall be responsible for all other construction staking, for taking precautions to preserve the stake locations, and is responsible for re-staking, if necessary. The as-installed locations of the earthquake drains shall not vary by more than six inches from the locations designated on the plans or approved shop drawings.

5.7 Earthquake drains that deviate from the plan locations by more than six inches, that are damaged, or improperly installed will be rejected. Rejected earthquake drains shall be abandoned in place. Replacement earthquake drains shall be placed as close as possible to the correct original locations.

5.8 The Contractor shall provide the Department with a means of verifying the plumbness of the mandrel and determining the depth of the earthquake drains. The equipment shall be checked for plumbness prior to installing each drain and shall not deviate from the vertical more than two percent (2%) during installation.

5.9 Earthquake drains shall be installed as shown on the plans and as directed by the Department. The replacement of existing geotechnical instrumentation, if present, damaged because of the Contractor's activities will be the responsibility of the Contractor, as described in the Special Provision for the geotechnical instrumentation, if required on the project.

5.10 Earthquake drains shall be installed from the working surface (top of fill soil) to the earthquake drain bottom elevations shown on the plans or to refusal. Refusal shall be defined as the point where the soils resist a reasonable effort at further penetration of the earthquake drains. The refusal criteria shall be established by the Engineer on the basis of existing soil borings and the initial earthquake drain installations to be performed by the Contractor in the presence of the Department's inspector, as specified herein. No earthquake drains shall be terminated above the design earthquake drain bottom elevations shown on the plans without the approval of the Engineer. The Engineer may vary the depths, spacing, and/or number of earthquake drains to be installed, and may revise the plan limits for this work based on the actual subsurface conditions encountered.

5.11 The prefabricated earthquake drains shall be cut off neatly at least six inches above the working layer, unless otherwise shown on the plans. The filter fabric shall be knotted at the top of the drain to prevent soil from entering the drain.

5.12 During earthquake drain installation, the Contractor shall provide the Department with a means of determining the depth of the advancing earthquake drain at any given time and the length of the drain installed at each location. A summary tabulation of the number and length (to the nearest ½-foot) of acceptable earthquake drains shall be submitted daily to the Department.

EXHIBIT 5 - SPECIAL PROVISIONS

5.13 Where obstructions are encountered below the working surface, the Contractor shall install a new drain within an 18 inch radius of the original location of the obstructed drain. A maximum of two additional attempts shall be made as directed by the Department for each obstructed earthquake drain. If the drain still cannot be installed to the design tip elevation, the drain location shall be abandoned and a new drain installed at a location directed by the Department. Locations where earthquake drains do not meet the depth criteria due to obstructions shall be clearly marked in the field. The Engineer will have the right to waive the replacement earthquake drain requirement upon written notice to the Contractor.

5.14 Pre-augering for the earthquake drain installation shall be allowed to advance the drains through compacted fill material or other obstructions. The Contractor shall be responsible for penetrating the overlying fill material or any dense layers or obstructions when encountered to satisfactorily install the earthquake drains. Satisfactory installation shall allow for clearing obstructions defined as any man-made or natural object or a stratum that prevents the proper insertion of the mandrel and installation of the earthquake drain. Pre-augering shall not be allowed for the first stage of construction where earthquake drains will penetrate through geotextile, if present.

The Contractor may use augering or other approved methods to loosen the soil and obstructing material prior to the installation of the drains. The obstruction clearance procedure is subject to the approval of the Engineer; however, such approval shall not relieve the Contractor of the responsibility to clear obstructions in accordance with the specifications.

If augering is the selected method, the augers shall have a minimum outside diameter equal to the largest horizontal dimension of the mandrel, shoe, or anchor, whichever is greatest. The maximum outside diameter of the auger shall be no more than three inches greater than the maximum dimension of the mandrel.

Obstruction clearance procedures shall be kept to a minimum and shall be used only when approved by the Engineer. Augering or other obstruction removal techniques shall not penetrate more than two feet into the underlying compressible soil.

Where obstructions are encountered, the following procedure shall be implemented in the listed sequence:

- a) The Contractor shall immediately notify the Department prior to completing the drain and prior to installing other drains.
- b) The Contractor shall then attempt to install drains adjacent to the obstructed location. Based upon the results of these installations and at the direction of the Department, the Contractor shall:
 1. Attempt to install an offset drain within 18 inches horizontally of the obstructed drain, or
 2. Implement obstruction clearance procedures and install the drain at the design location. Obstruction clearance procedures shall be used only as approved by the Engineer.

5.15 Earthquake drains shall be installed using a continuous push using static weight and vibration. Jetting or the use of an impact hammer will not be allowed to install the earthquake drains.

5.16 A mandrel shall be used to protect the earthquake drains during installation. The mandrel shall be withdrawn after installation of the earthquake drains. In no case will alternative raising and lowering of the mandrel during advancement be permitted. Raising the mandrel will be permitted only after completion of the earthquake drain installation to the bottom of the drain elevation shown on the plans or otherwise authorized by the Engineer.

6.0 MEASUREMENT

EXHIBIT 5 - SPECIAL PROVISIONS

6.1 Prefabricated Earthquake Drains: This item shall include the furnishing of all materials, supervision, equipment, crews, tools, required permits, survey stake out of earthquake drain locations, and other equipment and materials as necessary to properly execute the work.

The total length of earthquake drains for liquefaction mitigation shall be measured to the nearest one-half foot. The total length of earthquake drains to be paid for shall be as indicated on the plans.

7.0 BASIS OF PAYMENT

7.1 Prefabricated Earthquake Drains: Payment for earthquake drains shall be made at the contract unit price per linear foot of earthquake drains installed, which price shall be full compensation for the cost of furnishing the full length of the earthquake drain material, installing the earthquake drain, obstruction clearance, altering of the equipment and methods of installation in order to produce the required end result in accordance with the contract documents, and shall also include the cost of furnishing all tools, mobilization, materials, labor, equipment, supervision, survey stake out of earthquake drain locations, and all other costs necessary to complete the required work.

The Engineer may vary the depths, spacing, or numbers of earthquake drains to be installed and may revise the earthquake drain installation limits shown on the plans based on the actual subsurface conditions encountered. Such changes or revisions may increase or decrease the total quantity of the earthquake drains estimated based on the plans. In the event of such changes in required earthquake drain quantity, the payment for earthquake drains shall be made on the basis of the contract unit price per linear foot.

No payment will be made for earthquake drains, or for any delays or expenses incurred through changes necessitated by improper material or equipment.

Payments shall be made under:

Item No.	Pay Item	Pay Unit
2052210	Prefabricated Earthquake Drain with Filter Fabric	LF

(78) DIVISION 200: PREFABRICATED VERTICAL DRAIN WITH FABRIC

August 24, 2011

1.0 DESCRIPTION OF WORK

This work shall consist of furnishing all necessary submittals, materials, labor, equipment, and incidentals for the installation of prefabricated vertical drains in accordance with the details shown on the plans and the requirements of the Supplemental Specifications. The vertical drains shall consist of a band-shaped plastic core enclosed in a suitable jacket material. The vertical drains shall be installed at locations show on the plans, unless otherwise directed by the Department.

2.0 QUALITY ASSURANCE

2.1 Quality Control: The vertical drains shall be installed with equipment that will minimize the disturbance of the subsoil during the installation operation and maintain the mandrel in a vertical position. The Contractor shall consider the subsoils at the site when selecting equipment and developing the prefabricated vertical drain installation plan. The equipment shall have sufficient push force necessary to install the vertical drains through all existing subsurface material to the depths shown on the plans. The equipment shall have sufficient power to penetrate into the materials underlying the compressible stratum. The equipment shall have the capability of installing the vertical drains to a depth of not less than

EXHIBIT 5 - SPECIAL PROVISIONS

20 feet greater than the maximum vertical drain depth shown on the plans. The equipment shall be selected such that it will not force the fill soil into the existing soil, nor disturb the fill soil, nor cause any bearing capacity problems with the subgrade soils due to the weight of the equipment.

Approval of the sample vertical drain material by the Engineer will be required prior to delivery of the vertical drain material to the Project. The vertical drain manufacturer shall be a specialist in the manufacture of vertical drains and shall have produced a minimum of 1,000,000 linear feet of the vertical drain material proposed for the Project that have been used in successful applications within the past five years.

The vertical drains shall be free of defects, rips, holes, and/or flaws. During shipment and storage, the vertical drains shall be wrapped in a protective covering. The vertical drains shall be protected from sunlight, mud, dirt, dust, debris, and detrimental substances during shipping and on-site storage.

The Contractor shall certify and provide proof to the Department of experience in the work described. The Contractor shall have successfully installed at least 1,000,000 linear feet of vertical drains during the last five years and shall be a certified installer of the vertical drain manufacturer. In addition, the Contractor shall have successfully completed at least five projects within the last five years of similar size and complexity to that of the Project.

The Contractor's experience shall be documented by providing a project summary that includes for each referenced project, the project start and completion dates, total quantity of vertical drains installed, and a detailed description of the project, site conditions, and subsurface conditions. The project description shall include details of the vertical drain materials, the equipment and technique used to install the vertical drains, the average and maximum length of vertical drain installed, the client name and address, the name and telephone number of the representative of the consultant and owner for whom the work was performed and who can attest to the successful completion of the work, and any other information relevant to demonstrating the Contractor's qualifications.

The Contractor shall have a full-time supervisor who has been in responsible charge of supervising vertical drain installation operations for at least five projects in the last five years. The supervisor shall be present at the work site at all times during vertical drain installation operations. The Contractor shall provide a detailed resume of the supervisor's experience and qualifications. The acceptability of the supervisor, as well as any replacement for the supervisor, will be subject to the approval of the Department.

3.0 SUBMITTALS

3.1 Prefabricated Vertical Drain Installation Plan: Within thirty (30) calendar days after award of the contract or no later than thirty (30) calendar days before beginning prefabricated vertical drain installation, the Contractor shall submit to the Department for review a prefabricated vertical drain installation plan that includes as a minimum the following information:

- a) Size, type, weight, maximum pushing force, vibratory hammer rated energy, and configuration of the installation rig.
- b) Dimensions and length of the mandrel.
- c) Details of vertical drain anchorage.
- d) Detailed description of proposed installation procedures.
- e) Proposed methods for splicing the vertical drains.
- f) Proposed methods and equipment for pre-augering or spudding.

EXHIBIT 5 - SPECIAL PROVISIONS

- g) Submit documentation of the successful application of the proposed vertical drain installation operations.
- h) Submit shop drawings showing the planned locations and bottom elevations of all vertical drains and showing a unique identification number for each vertical drain. The installation sequence shall also be provided. The shop drawings shall also show the location of all settlement sensors or plates, the location of the abutment, and the limits of the final embankment.

3.2 Prefabricated Vertical Drain Material: At least thirty (30) calendar days before beginning vertical drain installation, the Contractor shall:

- a) Submit to the Department for testing three samples of the unspliced vertical drain to be used and three samples of proposed splices, with the accompanying manufacturer specifications for the vertical drain material. The samples of unspliced vertical drain shall be at least five feet long. Samples of spliced vertical drain shall be long enough to include the splice plus two feet of unspliced drain on both sides of the splice. The samples shall be stamped or labeled by the manufacturer as being representative of the vertical drain material having its specified trade name.
- b) Submit to the Department three samples of the proposed anchor plate to be used to anchor the vertical drains at the design depth shown on the plans.
- c) Submit to the Department manufacturer's literature documenting the physical and mechanical properties of the vertical drain and other similar projects where the same drain has been installed, including details on prior performance on these projects.
- d) The Contractor shall identify the proposed source of the materials prior to delivery to the site. The Contractor shall supply a manufacturer's material certification that the prefabricated vertical drain with fabric meets or exceeds the material requirements of this specification.

3.3 Submittal Reviews: Approval of the proposed materials, equipment, construction sequence, and method by the Department shall not relieve the Contractor of its responsibility to install the vertical drains in accordance with the plans and specifications. Approval by the Department of the method and equipment to be used to install the vertical drains shall be contingent upon satisfactory demonstration of vertical drain installation at the project site. If, at any time, the Department or the Engineer considers that the method of installation does not produce satisfactory vertical drains, the Contractor shall alter the method and/or equipment as necessary to comply with the Supplemental Specifications. The Department will be the sole judge in determining the adequacy of the Contractor's methods and equipment.

3.4 As-Built Plans: The Contractor shall provide the Department with "as-built" plans of the vertical drain installation. Such plans shall include the locations of the vertical drains, the date the drains were installed, the length of each drain below the fill soil surface elevation, the fill soil surface elevation at the drain installation, the "as-built" vertical drain tip elevation, and shall identify any rejected or abandoned drain installations. "As-built" plans shall be submitted at least weekly during vertical drain installation operations. A final "as-built" plan shall be submitted within seven calendar days of the completion of vertical drain installation in all embankment locations. The final "as-built" plans will be subject to the approval of the Department.

4.0 MATERIALS

4.1 The prefabricated vertical drain shall consist of newly manufactured materials and shall consist of a continuous plastic drainage core wrapped in a nonwoven geotextile material jacket. The jacket shall allow free passage of pore water to the core without loss of soil material or piping. The core shall provide

EXHIBIT 5 - SPECIAL PROVISIONS

continuous vertical drainage. The prefabricated vertical drain material shall have a minimum perimeter of 7-1/2 inches and a minimum thickness of 1/8 inch.

4.2 The jacket and core components shall conform to the following:

- a) The jacket shall be synthetic nonwoven geotextile capable of resisting bending, punching and tensile forces imposed during installation and during the design life of the vertical drain.
- b) The jacket material shall not be subject to localized damage (e.g., punching through the filter by sand/gravel particles).
- c) The jacket material shall be rigid enough to withstand lateral earth pressures due to embedment and surcharge so that the vertical flow capacity through the core will not be adversely affected.
- d) The jacket material shall be flexible enough to bend smoothly during installation and induced consolidation settlement without damage.
- e) The jacket material shall not undergo cracking and peeling during installation of the vertical drain.
- f) The core shall be continuous plastic material fabricated to promote drainage along the axis of the vertical drain. The assembled vertical drain shall be resistant against wet rot, mildew, bacterial action, insects, salts in solution in the ground water, acids, alkalis, solvents, and other ingredients in the site ground water.

4.3 Vertical drain materials shall be labeled or tagged in such a manner that the information for sample identification and other quality control purposes can be read from the label. As a minimum, each roll shall be identified by the manufacturer as to lot or control numbers, individual roll number, date of manufacture, manufacturer and product identification of the jacket and core.

During shipment and storage, the vertical drain shall be wrapped in burlap or similar heavy duty protective covering. The vertical drain shall be protected from sunlight, mud, dirt, dust, debris, and other detrimental substances during shipping and on-site storage.

Material which is damaged during shipment, unloading, storage, or handling, or which does not meet the requirements of the drain material will be rejected by the Department. No payment will be made for rejected material.

5.0 INSTALLATION

5.1 Prefabricated vertical drains shall be installed as indicated on the plans or as directed by the Department. The vertical drains shall be installed with equipment that will cause minimum disturbance of the subsoil during installation operations and maintain the mandrel in a vertical position. The vertical drains shall be installed using a mandrel or sleeve that shall be advanced through the soils to the required depth. The mandrel or sleeve shall protect the drain material from tears, cuts, and abrasion during installation and shall be retracted after each vertical drain is installed. To minimize disturbance of the subsoil, the mandrel or sleeve shall have a maximum cross-sectional area of 10 square inches. The mandrel or sleeve shall be sufficiently stiff to prevent wobble or deflection during installation.

5.2 Constant load or constant rate of advancement methods shall be used. A vibrator shall only be used when approved by the Engineer in areas where constant load or constant rate of advancement methods cannot install the vertical drains to the design depths. The use of an impact hammer will not be allowed.

5.3 The vertical drain shall be provided with an "anchor" plate or similar arrangement to anchor the bottom of the drain at the required depth during mandrel removal and to prevent soil from entering the bottom of the mandrel during drain installation. The anchorage shall be adequate to keep the bottom of

EXHIBIT 5 - SPECIAL PROVISIONS

the vertical drain at the required depth subject to approval and field verification by the Department. The corresponding dimension of the anchor shall conform as closely as possible to the breadth dimensions of the mandrel to minimize soil disturbance. The projected cross-sectional area of the mandrel and anchor combination shall not be greater than 14 square inches.

5.4 The Contractor shall notify the Department at least 24 hours prior to installation of the initial vertical drains at each embankment location to allow the Department sufficient time to provide the necessary inspection for the initial vertical drain installation. Installation of the initial vertical drains at each area shall not proceed without the presence of the Department's inspector. During the installation of the initial ten vertical drains at each embankment location, the Contractor shall demonstrate that the equipment, method, and material produce a satisfactory installation, as determined by the Department. Following completion of the initial drain installations at each embankment location, the Contractor shall not proceed with the installation of the remaining vertical drains at the embankment location until authorized by the Department.

5.5 If foundations have been previously installed, the prefabricated vertical drains shall be installed in a manner as to avoid foundations piles or spread footings. The location of the vertical drains relative to the foundations shall be determined and staked out prior to the installation of the prefabricated vertical drains. In addition, the Contractor shall be responsible for taking precautions to preserve the stake locations and is responsible for re-staking, if necessary.

5.6 Vertical drains shall be located, numbered, and staked out using a baseline and benchmark provided by the Contractor. The Contractor shall be responsible for all other construction staking, for taking precautions to preserve the stake locations, and is responsible for re-staking, if necessary. The as-installed locations of the vertical drains shall not vary by more than six inches from the locations designated on the plans or approved shop drawings.

5.7 Vertical Drains that deviate from the plan locations by more than six inches, that are damaged, or improperly installed will be rejected. Rejected vertical drains shall be abandoned in place. Replacement vertical drains shall be placed as close as possible to the correct original locations.

5.8 The Contractor shall provide the Department with a means of verifying the plumbness of the mandrel and determining the depth of the vertical drains. The equipment shall be checked for plumbness prior to installing each drain and shall not deviate from the vertical more than two percent (2%) during installation.

5.9 Splices or connections in the vertical drain material shall be done in accordance with the manufacturer's instructions and in a manner to insure continuity of the vertical drain material. Splicing of vertical drains shall be done by stapling to provide structural and hydraulic continuity of the drain. The jacket and core shall be overlapped a minimum of six inches.

5.10 Vertical drains shall be installed as shown on the plans and as directed by the Department. The replacement of settlement sensors or plates damaged because of the Contractor's activities will be the responsibility of the Contractor, as described in the Supplemental Specifications for Settlement Sensors or Settlement Plates.

5.11 Vertical drains shall be installed from the working surface (top of fill soil) to the vertical drain bottom elevations shown on the plans or to refusal in the stratum underlying the compressible stratum. The vertical drains shall penetrate through the compressible stratum, including any granular layers or lenses, and anchored in the underlying stratum. Refusal shall be defined as the point where the soils resist a reasonable effort at further penetration of the vertical drains. The refusal criteria shall be established by the Engineer on the basis of existing soil borings and the initial vertical drain installations to be performed by the Contractor in the presence of the Department's inspector, as specified herein. No vertical drains shall be terminated above the design vertical drain bottom elevations shown on the plans without the approval of the Engineer. The Engineer may vary the depths, spacing, and/or number of vertical drains to be installed, and may revise the plan limits for this work based on the actual subsurface conditions encountered.

EXHIBIT 5 - SPECIAL PROVISIONS

5.12 The prefabricated vertical drains shall be cut off neatly at least six inches above the working layer, unless otherwise shown on the plans.

5.13 During vertical drain installation, the Contractor shall provide the Department with a means of determining the depth of the advancing vertical drain at any given time and the length of the drain installed at each location. A summary tabulation of the number and length (to nearest tenth of a foot) of acceptable vertical drains shall be submitted daily to the Department.

5.14 Where obstructions are encountered below the working surface, the Contractor shall install a new drain within a 1-foot radius of the original location of the obstructed drain. A maximum of two additional attempts shall be made as directed by the Department for each obstructed vertical drain. If the drain still cannot be installed to the design tip elevation, the drain location shall be abandoned and a new drain installed at a location directed by the Department. Locations where vertical drains do not meet the depth criteria due to obstructions shall be clearly marked in the field. The Engineer will have the right to waive the replacement vertical drain requirement upon written notice to the Contractor.

5.15 Pre-augering or spudding for the vertical drain installation shall be allowed to advance the drains through compacted fill material or other obstructions. The Contractor shall be responsible for penetrating the overlying fill material or any dense layers or obstructions when encountered to satisfactorily install the vertical drains. Satisfactory installation shall allow for clearing obstructions defined as any man-made or natural object or strata that prevents the proper insertion of the mandrel and installation of the vertical drain.

The Contractor may use augering, spudding, or other approved methods to loosen the soil and obstructing material prior to the installation of the drains. The obstruction clearance procedure is subject to the approval of the Engineer; however, such approval shall not relieve the Contractor of the responsibility to clear obstructions in accordance with the specifications.

If augering is the selected method, the augers shall have a minimum outside diameter equal to the largest horizontal dimension of the mandrel, shoe, or anchor, whichever is greatest. The maximum outside diameter of the auger shall be no more than three inches greater than the maximum dimension of the mandrel.

Obstruction clearance procedures shall be kept to a minimum and shall be used only when approved by the Engineer. Augering or other obstruction removal techniques shall not penetrate more than two feet into the underlying compressible soil.

Where obstructions are encountered, the following procedure shall be implemented in the listed sequence:

- b) The Contractor shall immediately notify the Department prior to completing the drain and prior to installing other drains.
- c) The Contractor shall then attempt to install drains adjacent to the obstructed location. Based upon the results of these installations and the at the direction of the Department, the Contractor shall:
 - 1. Attempt to install an offset drain within 1 foot horizontally of the obstructed drain, or
 - 2. Implement obstruction clearance procedures and install the drain at the design location. Obstruction clearance procedures shall be used only as approved by the Engineer.

EXHIBIT 5 - SPECIAL PROVISIONS

5.16 Vertical drains shall be installed using a continuous push using either static weight or, when approved by the Engineer, vibration. Jetting or the use of an impact hammer will not be allowed to install the vertical drains.

5.17 A mandrel shall be used to protect the vertical drains during installation. The mandrel shall be withdrawn after installation of the vertical drains. In no case will alternative raising and lowering of the mandrel during advancement be permitted. Raising of the mandrel will be permitted only after completion of the vertical drain installation to the bottom of the drain elevation shown on the plans or otherwise authorized by the Engineer.

6.0 MEASUREMENT

6.1 Vertical Drains: This item shall include the furnishing of all supervision, equipment, crews, tools, required permits, survey stake out of vertical drain locations, and other equipment and materials as necessary to properly execute the work.

Vertical drains shall be measured to the nearest tenth of a foot. The length of the vertical drains to be paid for shall be the distance the installation mandrel tip penetrates below the working grade plus the required cut-off length above the working surface (top of fill soil). Payment will not be made for drains that are not anchored to the required depth.

No payment will be made for vertical drains placed deeper than the tip elevation designated on the plans unless authorized in writing by the Engineer.

6.2 Obstructions: Obstruction clearance by augering or spudding method shall be measured by the linear foot. The length of obstruction clearance to be paid for shall be the length from the working surface at the time of installation to the depth penetrated by the auger or spud, or to a depth two (2) feet into the underlying compressible soil, whichever is the lesser depth. The obstruction clearance depth is subject to verification by the Department.

Obstruction clearance by other methods shall be measured on a time and materials basis, subject to prior approval of the Department.

7.0 BASIS OF PAYMENT

7.1 Vertical Drains: Payment for vertical drains shall be made at the contract unit price per linear foot for acceptable drains, which price shall be full compensation for the cost of furnishing the full length of the vertical drain material, installing the vertical drain, altering of the equipment and methods of installation in order to produce the required end result in accordance with the contract documents, and shall also include the cost of furnishing all tools, materials, labor, equipment, supervision, survey stake out of vertical drain locations, and all other costs necessary to complete the required work.

The Engineer may vary the depths, spacing, or numbers of vertical drains to be installed and may revise the vertical drain installation limits shown on the plans based on the actual subsurface conditions encountered. Such changes or revisions may increase or decrease the total quantity of the vertical drains estimated based on the plans. In the event of such changes in required vertical drain quantity, the payment for vertical drains shall be made on the basis of the contract unit price per linear foot.

No payment will be made for vertical drains, or for any delays or expenses incurred through changes necessitated by improper material or equipment.

7.2 Obstructions: Payment for obstruction clearance using augering or spudding shall be made at the contract unit price per linear foot, which price shall be full compensation for the cost of preaugering, spudding, or performing other acceptable methods to clear obstruction and to satisfactorily install the vertical drains, including the cost of disposal of any surplus preaugered or obstruction clearance

EXHIBIT 5 - SPECIAL PROVISIONS

materials. The contract unit price shall include the cost of furnishing all tools, materials, labor, equipment, permits if required, and all other costs necessary to complete the required work.

Payment for the removal of obstructions using methods other than augering or spudding shall be on a time and materials basis as authorized by the Department.

Payments shall be made under:

Item No.	Pay Item	Pay Unit
8012300	Prefabricated Vertical Drain with Fabric	LF
8990204	Obstructions	LF

(79) DIVISION 200: REINFORCED SOIL SLOPES (RSS)

February 11, 2013

1.0 Description. This work shall consist of constructing a reinforced soil slope in accordance with these specifications, plans, or as directed by the RCE and in conformance with the lines, grades, dimensions, and design shown on the plans. The work addressed by this specification includes furnishing and placing of reinforced embankment backfill, placing geosynthetic soil reinforcements (primary and secondary), furnishing secondary soil reinforcement, furnishing and placing topsoil and any associated facing material, and temporary/permanent wire forms (excluding concrete slope protection).

2.0 Responsibility. The Contractor shall be responsible for the satisfactory construction of the reinforced soil slope feature including materials, methods, and installation based on information provided in the plans, specifications, and the geosynthetic reinforcement supplier's recommendations. The Contractor shall purchase the geosynthetic reinforcement, facing material, geotextile erosion control blankets, sod, fasteners, hold-downs, splice or seaming hardware, wire forms, and all necessary incidentals. The Contractor shall cooperate with the Department in the event that the Department chooses to randomly sample the stock reinforcement geosynthetic reinforcement.

3.0 Materials.

3.1 Geosynthetic Materials: The Contractor shall check the geogrid soil reinforcement upon delivery to ensure that the proper material has been received. Geosynthetic rolls shall be labeled per ASTM D 4873, Guide for Identification, Storage, and Handling of Geosynthetic Rolls. During all periods of shipment and storage, the geogrid shall be protected from temperatures greater than 60°C (140 degrees Fahrenheit), mud, dirt, dust, and debris. The manufacturer's recommendations regarding protection from direct sunlight shall be followed. At the time of installation, the geogrid shall be rejected if it has defects, tears, punctures, flaws, deterioration, or damage incurred during manufacture, transportation, or storage. The Contractor, at no additional cost to the Department, shall replace any geosynthetic reinforcement damaged during storage or installation. However, if approved by the RCE, placing a patch over the damaged area may repair torn or punctured sections. Any rejected geosynthetic shall be replaced or repaired at no additional cost to the Department.

For primary and secondary reinforcement, see Special Provision entitled "Geogrid Soil Reinforcement".

For separation of the granitic stone face material and the reinforced soil backfill or for preservation of the RSS, see Special Provision entitled "Geotextile for Separation of Subgrade & Subbase or Base Course Materials", if shown on the plans.

EXHIBIT 5 - SPECIAL PROVISIONS

For erosion control reinforcement, see 2007 Standard Specifications, if shown on the plans.

3.2 Reinforced Backfill Materials: All backfill material used in the reinforced zone as shown in the plans shall have an internal friction angle equal to or greater than the friction angles specified in the plans for the design. The internal friction angles shall be determined on remolded specimens and shall be determined using either the direct shear (AASHTO T-236) or the triaxial test with pore pressure measurements (AASHTO T-234). The fill materials shall conform to the following gradation limits as determined in accordance with SC T-4 and SC T-5 and shall have a Coefficient of Uniformity, C_u , of four (4) or greater:

Sieve Size	Percent Passing
¾ inch	100
No. 4	20-100
No. 40	0 - 60
No. 100	0 - 30
No. 200	0 - 15

All reinforced backfill shall have the following soil properties:

1. pH values shall range between 4.5 and 9.0 (AASHTO T-289).
2. Organic content shall not exceed 1.0 percent (weight of organic material to weight of total sample) as determined by AASHTO T-267 for material finer than no. 10 sieve.
3. Internal friction angle shall not be less than the values specified above as determined by the standard direct shear test, AASHTO T-236 or the triaxial test, AASHTO T-234, on the portion finer than the No. 10 sieve. Material test samples shall be compacted to 95% AASHTO T-99 (Method C or D) of maximum density at optimum moisture content.
4. The coefficient of uniformity, C_u , shall be 4 or greater. The coefficient of uniformity, C_u , shall be computed as follows:

$$C_u = \frac{D_{60}}{D_{10}}$$

Where D_{60} is the particle diameter at 60% passing and D_{10} is the particle diameter at 10% passing.

5. Plasticity Index (PI) shall be less than or equal to 6 and the Liquid Limit (LL) shall be less than or equal to 30 as determined by AASHTO T-90.

3.3 Testing Frequency: All soil property requirements shall be tested during initial source evaluation or if a change in source is requested. Reinforced backfill material shall be sampled once every 1,000 cubic yards and tested for gradation, organic content, liquid limit, plasticity index and pH. Reinforced backfill material shall be sampled once every 5,000 cubic yards and tested for internal friction angle. If the coefficient of uniformity, C_u , of the reinforced backfills is less than 4, the internal friction angle shall be tested every 2,000 cubic yards. A variation in testing frequency may be required if a variation in material gradation or composition is observed.

4.0 Construction.

4.1 Foundation Preparation. The foundation shall be prepared in accordance with the specifications, except as noted herein or on the plans. Unless otherwise shown on the plans or directed by the RCE, all

EXHIBIT 5 - SPECIAL PROVISIONS

existing vegetation and all unsuitable foundation materials shall be removed in those areas where the geosynthetic reinforcement is to be used for slope reinforcement.

Foundation soil shall be excavated to the lines and grades as shown on the plans or as directed by the RCE. Over-excavated or muck excavated areas shall be filled with compacted backfill material or as outlined in the special provisions. At the discretion of the RCE, foundation soil shall be proofrolled prior to backfill and geogrid placement.

Where the geosynthetic application is for slope reinforcing on firm foundation soils, the graded area shall also be proofrolled with a vibratory roller weighing a minimum of eight tons for at least five passes in the presence of the RCE or as directed by the RCE. Any soft or loose foundation subsoils, in the opinion of the RCE, incapable of sustaining the required proofrolling shall be removed and replaced in accordance with the specifications.

Surfaces on which reinforcements are to be placed shall be uniform, smooth and free of abrupt changes in slope, debris and irregularities that could damage the reinforcement. Any areas outside the limits of disturbance shown on the plans that are damaged as part of this work shall be promptly repaired and restored to their original condition at the Contractor's expense. The Contractor shall make every possible effort to avoid such damage.

4.2 Fill Placement: The moisture content of the backfill material prior to and during compaction shall be approximately uniform throughout each layer of material. Backfill material shall have an in-place moisture content on the dry side of the optimum moisture content. Excessively moist backfill materials shall not be transported to the site for any reason.

The reinforced embankment shall be constructed in accordance with Section 205. Reinforced backfill shall be compacted not less than 95 percent of the maximum dry density in accordance with AASHTO T-99 (Method A or C as applicable) or SC T-25 (Method A or C as applicable). Compaction control testing of the reinforced backfill shall be performed with a minimum frequency of one density test per every two lifts for every 25 feet of reinforced slope at bridge abutments (including the first 150 feet of reinforced slope parallel to the roadway) and every 75 feet of reinforced slopes along roadways (more than 150 feet away from bridge abutments). Sheepfoot or grid-type rollers shall not be used for compacting backfill within the reinforced backfill.

Backfill shall be placed, spread, and compacted in such a manner that minimizes the development of wrinkles in and/or movement of the geogrid. Tracked construction equipment shall not be operated directly upon the geogrid. A minimum fill thickness of 6 inches is required prior to operation of tracked vehicles over the geogrid. Turning of tracked vehicles should be kept to a minimum to prevent tracks from displacing the fill and damaging the geogrid. Rubber tired equipment may pass over the geogrid reinforcement at slow speeds, less than 10 mph. Sudden braking and sharp turning shall be avoided.

Backfill materials shall have a placement moisture content not more than 2 percentage points below the optimum moisture content and not more than the optimum moisture content. Backfill material with placement moisture content in excess of the optimum moisture content shall be removed and reworked until the moisture content is uniformly acceptable throughout the entire lift.

The maximum soil lift thickness (loose) will be 8 inches. The contractor shall decrease this lift thickness if necessary to obtain the density. Backfill compaction shall be accomplished without disturbance or distortion of the reinforcement. A minimum of 6 inches of backfill material shall be maintained at all times between the contractor's equipment and the soil reinforcement.

At the end of each day's operations, the Contractor shall shape the last level of backfill to permit runoff of rainwater away from the slope face. In addition, the contractor shall not allow surface runoff from adjacent areas to enter the reinforcement zone until this zone is protected from infiltration. Any damage or movement caused by erosion, sloughing, or saturation of the reinforced backfill or retained backfill shall be repaired at the Contractor's expense.

4.3 Geosynthetic Placement: Due to the unique nature of this type of construction, the Contractor shall negotiate with the geosynthetic supplier to provide a qualified and experienced representative of the geogrid manufacturer or its supplier for a minimum of one day of site assistance at the start of installation, to assist the Contractor and the RCE in the proper construction/installation techniques. Thereafter, the representative shall be available on an as needed basis, as requested by the RCE, during construction of the remainder of the project. The Contractor shall submit a copy of any instructions provided by the supplier to the RCE prior to beginning installation.

The geosynthetic shall be placed at the proper elevation, location, and orientation as shown on the plans. Geogrid shall be laid at the proper elevation and orientation as shown on the construction drawings or as directed by the RCE. Primary uniaxial strength geogrid shall be oriented perpendicular to the slope face or centerline. Primary biaxial strength geogrid may laid out either perpendicular to the slope face or parallel to the slope face provided that it is being placed over a stable subgrade (not soft soils). If a biaxial geogrid is being placed over a soft foundation, the geogrid shall be placed perpendicular to the slope face. The Contractor shall verify correct orientation (roll direction) of the geogrid. Geogrid may be temporarily secured in-place with staples, pins, sand bags, or backfill as required by fill properties, fill placement procedures, or weather conditions, or as directed by the RCE. The geosynthetic material shall be pulled tight and secured as necessary to lay flat against the soil prior to fill placement.

Unless otherwise called for on the plans, adjacent rolls of geosynthetic shall be butted together to maintain 100% horizontal coverage. Vertical spacing of the primary soil reinforcing layers shall not exceed the locations shown in the plans.

Primary geogrid shall not be spliced or overlapped in the primary strength direction. No overlapping is required between adjacent rolls of primary soil reinforcement.

Secondary soil reinforcement shall be overlapped a minimum of 12 inches along the roll edges parallel to the reinforcement direction. Overlaps are not allowed for edges perpendicular to the reinforcement direction.

Only that amount of geosynthetic material (including reinforcement and drainage material) required for immediately pending work shall be placed to prevent undue damage to the materials. After a layer of geosynthetic has been placed, the next succeeding layer of soil shall be placed and compacted. After the specified soil layer has been placed and compacted, the next geosynthetic layer shall be installed. The process shall be repeated for each subsequent layer of geosynthetic and soil.

Equipment shall not operate directly on the geosynthetics. Equipment shall be operated such that no turning movements occur on the areas where geosynthetic is in place with less than 12 inches of fill cover. Ruts of more than three inches in depth shall be filled and compacted as they develop.

The Contractor at no additional cost to the Owner shall replace any geogrid damaged during installation.

5.0 Method of Measurement and Basis of Payment. The quantity of geosynthetic reinforced slope to be used for payment shall be the area, in square feet, of the vertical projection of the slope face, measured from the top of slope to the proposed final ground line at the toe of the slope and from the beginning to end limits as shown on the plans, regardless of the length or number of layers of geosynthetic within the reinforced volume and including any reinforcement required below the toe of the slope elevation.

The quantity, determined as provided above, shall be paid for at the contract unit price per vertical square foot of geosynthetic reinforced soil slope. Payment shall be full compensation for all work, materials, and services required including, the soil slope secondary reinforcements, placement of reinforced embankment backfill, topsoil, any associated facing material (geotextile for slope preservation),

EXHIBIT 5 - SPECIAL PROVISIONS

and temporary wire forms (excluding concrete slope protection), installation, testing, and required submittals. The primary geosynthetic reinforcing will be measured and paid for as "Geogrid Reinforcement (Uniaxial)". The reinforced backfill zone material will be measured and paid for as "Borrow Excavation". Additional costs associated with using select material within the reinforced backfill zone will be included in the Reinforced Soil Slopes (RSS) item.

Payment will be made under:

Item No.	Pay Item	Pay Unit
2061200	Reinforced Soil Slopes (RSS)	SF

(80) DIVISION 200: MONITORING DEVICES - PIEZOMETER

Supplemental Specification for Monitoring Devices – Piezometer is revised as follows:

Section 2 Paragraphs 2 and 3 shall be replaced with the following:

"Piezometer shall be installed from the working surface to the depths shown on the plans. These depths refer to the middle of the piezometer referenced to the original ground surface. Enough cable shall be provided to run from the pressure cell to the location of the Vibrating Wire Data Collection Center (VW-DCC) plus 10 feet for each instrument. The cable used to connect the pressure cell to the VW-DCC shall meet the requirements of the instrument manufacturer/supplier. The Contractor shall supply non-conductive conduit to encase the cable between the pressure cell and VW-DCC. The conduit shall have a minimal nominal diameter of 1 inch and meet the requirements of Schedule 80 materials. Provide enough conduit to enclose all lengths of buried cable from the pressure cells to the VW-DCC. All connects in the conduit and in the cable between the pressure cell and VW-DCC shall be water proof.

During roadway construction and any delay period for settlement, the piezometers will be read and analyzed by the Engineer at the same times outlined in the Special Provision for Settlement Plates. If the piezometers indicate excessive excess pore pressures at a given location during embankment placement operations, the placing of embankment material shall be suspended."

The following shall be added to the end of Section 2 Paragraph 4:

"Figure 1 depicts the installation of a single piezometer in a borehole; however, multiple piezometers may be placed in the same borehole. The installation of multiple piezometers is not shown for clarity."

Section 4 Paragraph1 shall be replaced with the following:

Unit price bid for "Monitoring Devices-Piezometer" shall include all costs associated with supplying, installing, and maintaining the monitoring devices. The Contractor will monitor the devices throughout construction of the embankment and for up to a period of one year after the final delay period for settlement when embankment construction is completed. The Contractor will be responsible for ensuring the piezometers are in working order and accessible once the embankment is complete."

(81) DIVISION 200: SETTLEMENT SENSORS

1.0 GENERAL

3.2 Scope

EXHIBIT 5 - SPECIAL PROVISIONS

The work under this Section consists of furnishing all supervision, labor, material, equipment, and related services necessary to furnish and install settlement sensors as indicated on the Drawings and specified herein. The Contractor shall accommodate the Engineer in the monitoring of settlement sensors.

The purpose of the settlement-monitoring program is to:

3. Confirm estimates of the time rate of settlement of embankments and retaining walls during construction so that construction methods may be adjusted, if necessary, to meet the project schedule;
4. Confirm that settlement is sufficiently completed prior to final grading and paving of roadways supported on embankments and retaining walls.

Consolidation settlement of the foundation soils is expected to occur during and for a period after construction of new embankments and retaining walls. The magnitude and rate of the settlement will depend on the variation of the stratigraphy and consolidation properties of the foundation soils. To effectively manage the post-construction settlement, settlement sensors shall be used to monitor the magnitude and rate of settlement during construction.

Settlement sensors shall be furnished and installed by the Contractor in the presence of the Engineer. Settlement sensors shall consist of a steel plate with the attached sensor equipment designed to be buried within soil fill and connected to a liquid reservoir, which is set in stable ground that is not subject to settlement. Settlement measurements are referenced to the fluid level of the reservoir supported on stable ground.

3.3 Responsibilities of Contractor:

The Contractor shall notify the Engineer at least five (5) working days prior to the installation of settlement sensors.

The Contractor shall furnish and install the settlement sensors in the presence of the Engineer.

The Contractor shall provide a licensed surveyor to stake out and provide as-built locations and elevations of all settlement sensors and liquid reservoir locations.

The Contractor shall protect the settlement sensors and liquid reservoirs from damage for the duration of the Contract.

The Contractor shall provide the Engineer safe access to the settlement sensors for the purpose of data collection for the duration of the Contract.

The Contractor shall be responsible for locating all settlement sensors in the field and ensuring that no conflicts exist between settlement sensors, liquid reservoir locations and existing and proposed structures, utilities or other construction proposed or present at the site.

3.4 Site Preparation

The Contractor shall ensure a firm base on which heavy equipment and/or other necessary equipment can be operated safely under its own power for installation of settlement sensors.

The Contractor shall accurately locate all settlement sensors in accordance with Drawings. Settlement sensors shall be adjusted by the Contractor, with the approval of the Engineer, to avoid utilities, foundations, and all other underground construction.

3.5 Existing Soil Conditions:

EXHIBIT 5 - SPECIAL PROVISIONS

The subsurface conditions encountered at the site are presented in the Contract Plans and documents.

2.0 PRODUCTS

2.1 Settlement Sensor

The settlement sensor shall consist of a 12-in. square, ¼-in. thick steel plate with an attached vibrating wire pressure sensor. A liquid reservoir and readout panel shall also be supplied in a waterproof casing. The Contractor shall supply weather resistant locks and keys for the casings. The Contractor shall provide all keys to the Engineer. The liquid reservoir shall have a graduated scale attached so that the liquid level can be checked visually. The manufacturer's instruction and installation manual shall be supplied with the settlement sensor. The sensor shall have the signal cable and tubing attached and factory saturated with a 50% ethylene glycol antifreeze solution, ready for connection to the readout panel and liquid reservoir. The liquid reservoir shall have two tubing connections to the sensor to allow for flushing if necessary. Additional antifreeze solution shall be provided to fill the liquid reservoir and saturate the tubing connections. The vibrating wire pressure sensor shall be self-compensated for variations in barometric pressure, and have a built in temperature sensor for correction of temperature variations. The vibrating wire sensor shall be vented to the air space at the top of the liquid reservoir to accomplish the self-compensation for barometric pressure, and a moisture trap shall be included in series with the vent tubing. The settlement sensor shall have a minimum range of 5 ft, a resolution of 0.01 ft, and a system accuracy of ± 0.02 ft.

Settlement sensor model 4650 manufactured by Geokon, Inc. of Lebanon, NH, or equivalent, shall be supplied. Catalog sheet for 4650 Settlement sensor is attached at the end of this specification for reference.

2.2 Support Post

A metal or wooden post shall be provided for mounting the liquid reservoir and readout panel. The post shall be long enough so that it can be set a minimum of 3-ft below the stable ground surface, and the readout panel will be mounted no less than 2-ft off of the ground.

2.3 Sand Backfill

Clean sand backfill with no particles larger than 3/8-in. shall be provided to backfill around the signal cable and tubing leading from the settlement plate to the liquid reservoir and readout panel.

2.4 Incidentals

Incidental conduit, hardware, fasteners, tools, electronic readouts and the like, as necessary to install the system in accordance with the manufacturer's manual, shall be provided.

3.0 SUBMITTALS

The Contractor shall submit the Specification sheet for the settlement sensor prior to purchase of settlement sensor for review and approval of the Engineer. Locations for the liquid reservoir shall also be submitted for approval, so that the proper length of signal cable and tubing can be purchased.

Upon receipt of the settlement sensor, the Contractor shall submit copies of calibration sheets and the manufacture's installation and instruction manual for review and approval of the

EXHIBIT 5 - SPECIAL PROVISIONS

Engineer, and shall make available the settlement sensor for inspection by the Engineer.

Within 1 week following installation, the contractor shall submit an installation record for each settlement plate which includes the plate designation, station, offset, and elevation of the Settlement sensor, and station offset and elevation of the liquid reservoir. The settlement sensor shall be located to an accuracy of 0.01 ft (both vertically and horizontally).

4.0 EXECUTION

4.1 Settlement Sensor Installation

The Contractor shall furnish and install settlement sensors in accordance with the Drawings and these specifications and in the presence of the Engineer. Settlement sensors shall be installed prior to embankment or retaining wall construction and following installation of wick drains, stone columns, or other ground improvement, and grubbing and clearing in the immediate vicinity of each settlement plate. Settlement sensor locations shall be adjusted by the Contractor only with the approval of the Engineer.

Settlement sensor installation shall be in accordance with the manufacturer's recommendations as presented in their instruction and installation manual. The liquid reservoir shall be located clear of the construction area, in an area where no fill will be placed and no settlement is anticipated. The liquid reservoir and readout panel shall not be located in drainage swales, storm water detention ponds or other areas where the panel may become submerged. A licensed surveyor shall provide a survey of the installed sensor and liquid reservoir. The survey reference point for the liquid reservoir and readout panel shall be permanently marked so that subsequent surveys may be referenced to this mark.

4.2 Allowance for Settlement Sensor Monitoring

The contractor shall accommodate the Engineer during construction to provide safe and timely access to settlement sensors for the purpose of obtaining measurements, as construction progresses. Evaluation of the settlement sensor data will be the responsibility of the Engineer.

4.3 Fill Height Survey and Liquid Reservoir Survey

The Contractor shall make a survey of the ground surface elevation above each settlement sensor twice weekly while fill is being placed, and once every two weeks when fill is not being placed, unless directed otherwise by the Engineer. The purpose of these measurements is to provide the Engineer with a time-history of the embankment or retaining wall height for correlation with settlement measurements. Survey of the liquid reservoir and readout panel elevation shall be made every four weeks, or if disturbance of the liquid reservoir is suspected, or as directed by the Engineer. Surveys made by the Contractor shall be provided to the Engineer within one week.

4.4 Protection of Settlement Sensors

The Contractor shall protect settlement sensors from damage and vandalism for the duration of the Contract and repair or replace damaged or inoperative settlement sensors at no cost to the Department.

4.5 Abandonment of Settlement Sensors

Once the Engineer has determined that the settlement sensors have served their purpose and are no longer needed, they shall be abandoned in-place. The Contractor shall remove recoverable portions of the settlement sensor, likely consisting of only the liquid reservoir and readout panel. All recoverable instrumentation shall remain property of the Contractor. The

EXHIBIT 5 - SPECIAL PROVISIONS

Contractor shall remove the ethylene glycol antifreeze solution from the buried tubing that is left in place by use of either a vacuum pump or by blowing out the tubing with air pressure. The antifreeze solution shall be contained and disposed of offsite in a proper manner by the Contractor.

5.0 METHOD OF MEASUREMENT

The number of settlement sensors, as provided in the plans, will be paid for at the contract unit price bid for "Monitoring Device - Settlement Sensors" which shall include all equipment, including but not limited to the settlement sensor, liquid reservoir, water proof casing; mobilization; labor; surveys; materials; incidentals and abandonment required by these Specifications.

6.0 BASIS OF PAYMENT

The price and payment for this work shall be full compensation for furnishing the necessary Settlement Sensor, including the settlement sensor, the liquid reservoir, the waterproof casing, surveys and incidental items based on the acceptance of the Settlement Sensor installation by the Engineer.

Payments shall be made under:

Item No.	Pay Item	Pay Unit
2038115	MON. DEVICE – SETTLEMENT SENSOR	EA

Model 4650 Settlement System



● Model 4650 Settlement System.

Applications

The Model 4650 is designed for remote measurement of the settlement of a point in or below fills, surcharges, embankments, etc. Systems with tube lengths of up to 300 m have been used successfully to measure settlements in earth dam embankments.

Operating Principle

A vibrating wire pressure sensor is attached to a settlement plate located at the point of settlement. The sensor is connected via two liquid-filled tubes, extending laterally, to a reservoir located on stable ground. The sensor measures the hydraulic head of liquid between the sensor and reservoir locations.

Advantages and Limitations

A vented cable runs from the sensor to the remote readout location and connects to the reservoir so that barometric pressure fluctuations do not affect the readings.

The liquid-filled tubes can be flushed to remove any air bubbles that might form.

It is possible to perform in-situ checks at any time on both the calibration and zero stability.

Technical Specifications

Standard Ranges ¹	7, 17 m (20, 50 ft.)
Resolution/Sensitivity	2, 4 mm (0.08, 0.16 in.)
System Accuracy ²	±4 to ±6 mm (±0.16 to ±0.24 in.)
Temperature Range ¹	-20°C to +80°C

¹Other ranges available on request.
²Sensor accuracy 0.1% F.S.

EXHIBIT 5 - SPECIAL PROVISIONS

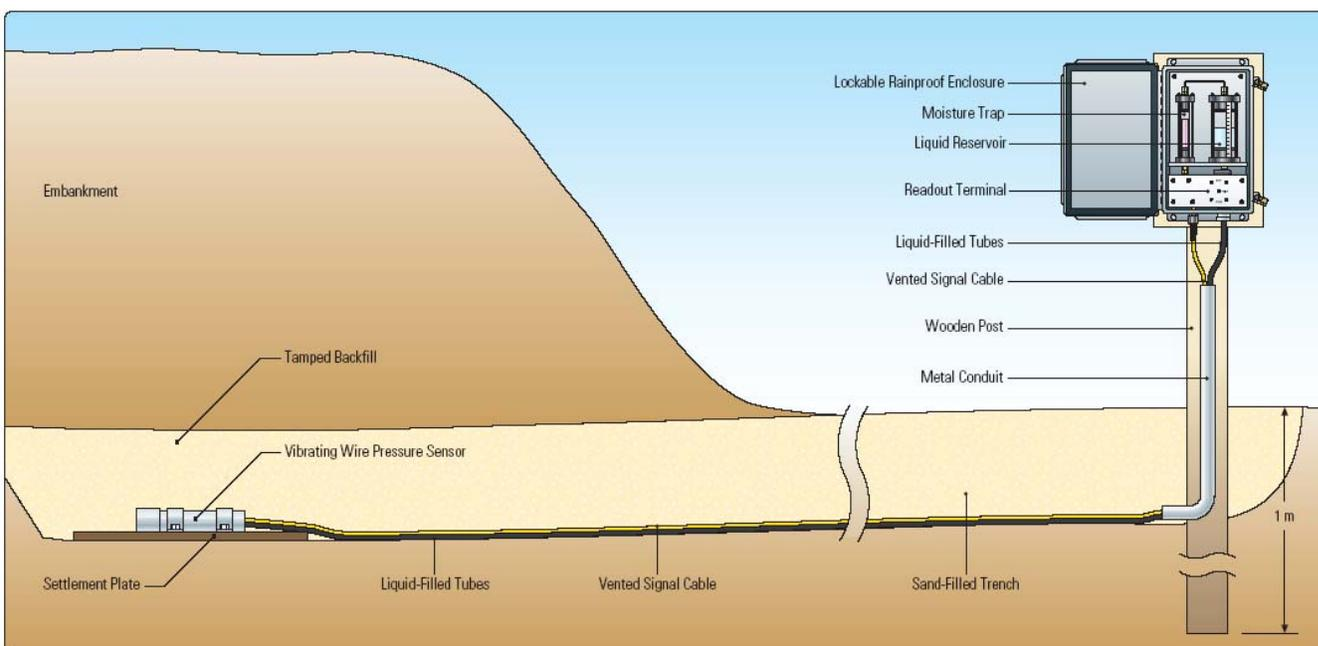

● Model 4650 installation for the remote measurement of subsurface settlement beneath a large embankment.

(82) DIVISION 200: TOTAL PRESSURE CELLS

1.0 Description. This work includes furnishing all supervision, materials, equipment, labor, and related services necessary for installing pressure monitoring instrumentation consisting of a vibrating wire (VW) total (earth) pressure cell at the locations indicated in the plans and in accordance with these specifications. This item includes the furnishing of as-built drawings of actual locations where instrumentation was installed, survey data recorded during instrumentation installation, and installation field reports. Also included in this item of work is the initial and periodic/continuous recording of total pressure readings and reporting to the Engineer in accordance with the Department's Geotechnical Instrumentation Monitoring Plan for the entire duration of the project.

The purpose of the instrumentation monitoring program is to:

5. Confirm estimates of load transfer to the stone columns beneath the column supported embankment;
6. Confirm that the soil located between the stone columns does not carry excessive loads that could induce consolidation settlement, thus affecting the performance of the bridge foundations.

The Contractor shall be familiar with project geotechnical conditions and recognize that geotechnical data is available with geotechnical boring logs, laboratory testing results, and other pertinent information.

2.0 Pressure Instrumentation. VW total (earth) pressure cell shall consist of 2 steel plates welded at the edges with an incompressible fluid filled void located between the plates. The void between the plates shall be hermetically sealed. The incompressible fluid shall be in contact with a pressure transducer that converts the pressure into an electronic signal that is recorded by the data collection unit outside of the embankment. The pressure cell shall be able to measure up to 50 psi and shall be designed to withstand point loads induced by stone of the stone columns and the load transfer platform on both sides. The aspect ratio (D/t – D - diameter of cell; t – thickness of cell) of the cell shall be greater than 15. The pressure cells shall have an accuracy ± 0.1 percent with a thermal affect of < 0.05 percent for a temperature range of -4°F to 176°F . Enough cable shall be provided to run from the pressure cell to the location of the Vibrating Wire Data Collection Center (VW-DCC) plus 10 feet for each instrument. The cable used to connect the pressure cell to the VW-DCC shall meet the requirements of the instrument

EXHIBIT 5 - SPECIAL PROVISIONS

manufacturer/supplier. The Contractor shall supply non-conductive conduit to encase the cable between the pressure cell and VW-DCC. The conduit shall have a minimal nominal diameter of 1 inch and meet the requirements of Schedule 80 materials. Provide enough conduit to enclose all lengths of buried cable from the pressure cells to the VW-DCC. All connections in the conduit and in the cable between the pressure cell and VW-DCC shall be water proof.

3.0 Submittals. Within 30 calendar days before installing the total pressure cells, the Contractor shall submit to the Department for review the qualifications of the personnel installing the instrumentation as well as the installation plan. The submittals shall contain as a minimum the following information.

3.1 Qualifications: The Contractor shall identify the licensed surveyor who shall be responsible for providing survey services during the installation of the total pressure cell. The Contractor shall also identify the geotechnical engineer that will be responsible for installing the total pressure cell in accordance with the Department's Geotechnical Instrumentation Monitoring Plan. The geotechnical engineer's experience in providing instrumentation services using a total pressure cell and remote VW-DCC in accordance with the plans and Contract Documents shall be documented by providing a project summary, of at least three projects, that includes for each project the project name, role in providing instrumentation services, type of total pressure cell and VW datalogging equipment used, duration of the project (i.e. dates), magnitude of settlements, client name and address, name and phone number of representative of the consultant and owner for whom the work was performed and can attest to the successful completion of the work, and any other information relevant to demonstrating the geotechnical engineer's qualifications. In addition, the manufacturer/supplier shall also be on-site during the initial installation of the total pressure cells to ascertain that all instruments have been connected correctly. The manufacturer/supplier shall also be available for questions from either the geotechnical engineer responsible for maintaining the total pressure cells or from the Department concerning the data being collected.

3.2 Installation Plan: The proposed total pressure cell installation plan shall include as a minimum the following information:

1. The Contractor shall submit the Specification sheet for the proposed total pressure cell system prior to purchase for review and approval of the Engineer.
2. Submit locations where the total pressure cells will be installed for approval. The location should indicate the number of the stone column that the total pressure cell will be located on or the numbers of the surrounding stone columns for the total pressure cell located between stone columns.
3. Proposed installation method of total pressure cell.
4. Proposed method to protect total pressure cell and cable during construction from construction equipment and vandalism.

3.3 Submittal Reviews: Approval of the personnel qualifications and installation plan by the Department shall not relieve the Contractor of its responsibility to successfully install the total pressure cells in accordance with the plans and specifications. Approval by the Department of the total pressure cell installation and instrumentation plan shall be contingent upon satisfactory demonstration that the instrumentation is meeting the objectives of the Department's Geotechnical Instrumentation Monitoring Plan. If, at any time, the Department or the Engineer considers that the method of installation or monitoring does not produce satisfactory results, the Contractor shall alter the method and/or equipment as necessary to comply with the Special Provisions and Department's Geotechnical Instrumentation Monitoring Plan. The Department will be the sole judge in determining the adequacy of the Contractor's installation and monitoring results and whether monitoring can be discontinued.

4.0 Delivery, Storage, and Handling. The Contractor shall check all materials and equipment upon delivery to ensure that the proper items are received and are not damaged. All materials shall be stored and maintained in a clean, uncontaminated condition throughout the course of the project. Upon receipt of the total pressure cells, the Contractor shall submit copies of the manufacture's installation and instruction

EXHIBIT 5 - SPECIAL PROVISIONS

manual for review and approval by the Engineer, and shall make available the data logging system for inspection by the Engineer.

5.0 Total Pressure Cell Installation. Upon receipt of the total pressure cell, the Contractor shall submit copies of calibration sheets and the manufacturer's installation and instruction manual for review and approval by the Engineer, and shall make available the pressure cell for inspection by the Engineer.

The Contractor shall notify the Engineer at least fourteen (14) days prior to the installation of total pressure cells. Total pressure cells shall be furnished and installed by the Contractor in accordance with the plans and this specification and in the presence of the Engineer.

The Contractor shall be responsible for locating all total pressure cells in the field and ensuring that no conflicts exist between total pressure cells and foundations, structures, utilities or other construction proposed or present at the site.

The Contractor shall provide a licensed surveyor to stake out and provide as-built locations and elevations of all total pressure cells locations.

Total pressure cells shall be installed prior to construction of the load transfer platform and embankment construction and following installation of the stone columns. The Contractor shall ensure a firm base on which heavy equipment and/or other necessary equipment can be operated safely under its own power for installation of total pressure cells.

Total pressure cell installation shall be in accordance with the manufacturer's recommendations as presented in their instruction and installation manual. The total pressure cell will be connected to the VW-DCC in accordance with the plans, contract documents, and manufacturer's recommendations.

The Contractor shall accurately locate all total pressure cells in accordance with plans. Total pressure cells may be adjusted by the Contractor, with the approval of the Engineer, to avoid utilities, foundations, and all other underground construction.

Within 1 week following installation, the contractor shall submit an installation record for each total pressure cell, which includes the instrumentation identification as provided in the plans, station/alignment, offset, and elevation of the total pressure cell. The total pressure cell shall be located to an accuracy of 0.01 ft (both vertically and horizontally).

The Contractor shall protect total pressure cell locations from damage and vandalism for the duration of the Contract and repair or replace damaged or inoperative total pressure cells at no cost to the Department.

6.0 Abandonment of Total Pressure Cells. Once the Engineer has determined that the total pressure cells have served their purpose and are no longer needed, the total pressure cells shall be abandoned in-place. The Contractor shall remove recoverable portions of the total pressure cell. All recoverable instrumentation shall remain property of the Contractor. The Contractor shall remove no more than 2 feet of the conduit that extends into the embankment and shall seal the conduit left in place within the embankment using a lean grout mix.

7.0 Method of Measurement. The number of total pressure cells, as provided in the plans, will be paid for at the contract unit price bid for "Monitoring Device – Total Pressure Cells" which shall include all equipment, including but not limited to the total pressure cell, water proof casing; mobilization; labor; surveys; materials; incidentals and abandonment required by these Specifications along with total pressure cell data as outlined in the Geotechnical Instrumentation and Monitoring Plan. Payment will not be made for total pressure cells that malfunction or are rejected for their inability to perform, or do not meet the requirements in the plans and these specifications.

EXHIBIT 5 - SPECIAL PROVISIONS

8.0 Basis of Payment. The price and payment for this work shall be full compensation for furnishing the necessary Total Pressure Cell, including the total pressure cell, the waterproof casing, surveys, data as outlined in the Geotechnical Instrumentation and Monitoring Plan, and incidental items based on the acceptance of the Total Pressure Cell installation by the Engineer.

Payments shall be made under:

Item No.	Pay Item	Pay Unit
2038108	MON. DEVICE – TOTAL PRESSURE CELL	EA

(83) DIVISION 200: VIBRATING WIRE DATA COLLECTION CENTERS

February 23, 2012

1.0 Description. This work includes furnishing all supervision, materials, equipment, and labor, and related services necessary for providing and maintaining a Vibrating Wire Data Collection Center (VW-DCC) at the locations indicated in the plans and in accordance with these specifications. This work consists of automating the data collection for vibrating wire rod extensometers and piezometers with a real-time system that is accessible via the internet in accordance with the Department’s Geotechnical Instrumentation Monitoring Plan for the entire duration of the project as determined necessary for evaluating the settlement instrumentation of the embankments being constructed.

2.0 Vibrating Wire Data Collection Center. The Vibrating Wire Data Collection Centers (VW-DCC) is an automated centralized vibrating wire data collection center. The VW-DCC will be used to collect vibrating wire rod extensometer (VWRE) and piezometer (PZ) readings. Temperature readings shall also be collected when instrumentation contains thermistors. The automated collection of VW data shall be accomplished by using a data logging system that is sufficiently capable to monitor the VW sensors indicated in the plans and with the capability of adding four additional rod extensometers and six piezometers to the system. Sufficient ports shall be provided to also monitor temperature. The reserve instrumentation monitoring capacity can be either achieved by using a data logging system with sufficient ports or by having the capability to expand the system if needed. The Contractor shall maintain compatibility between the data logging system and the rod extensometers and piezometer instrumentation. In order to maintain compatibility of the systems and be able to get technical assistance from the manufacturer during installation and throughout the project the VW-DCC system should be supplied/manufactured by the same company that is supplying the rod extensometer and piezometer instrumentation. In addition, the VW-DCC shall have the following features:

- Data logging system with sufficient capacity to read and save instrumentation readings.
- The data logging system shall have the reserve capacity to add additional instrumentation if needed.
- Powered by on-site AC current
- Battery power back-up with surge suppression
- Telephone/cellular access for transmitting data through the internet
- Dedicated server for storing and running viewing software.
- On-line instrumentation software for reviewing/downloading instrumentation data
- Enclosure that protects the equipment from damage during construction, vandalism, and weather.

3.0 Submittals. Within 30 calendar days before installing the VW-DCC, the Contractor shall submit to the Department for review the personnel qualification, installation plan, and monitoring plan. The submittals shall contain as a minimum the following information.

3.1 Qualifications: The Contractor shall identify the geotechnical engineer that will be responsible for installing and maintaining the VW Data Collection Center. The same geotechnical engineer that is responsible for the vibrating wire rod extensometers and piezometers will also be responsible for the VW-DCC. The geotechnical engineer’s experience in providing automated data logging capabilities such as the VW-DCC in accordance with the plans and Contract Documents shall be documented by providing a project summary, of at least three projects, that includes for each project the project name, role in providing instrumentation services, type of data logging system, equipment used, duration of the project

EXHIBIT 5 - SPECIAL PROVISIONS

(i.e. dates), client name and address, name and phone number of representative of the consultant and owner for whom the work was performed and can attest to the successful completion of the work, and any other information relevant to demonstrating the geotechnical engineer's qualifications. In addition, the manufacturer/supplier shall also be on-site during the initial installation of the VW-DCC to ascertain that all instruments have been connected correctly. The manufacturer/supplier shall also be available for questions from either the geotechnical engineer responsible for maintaining the VW-DCC or from the Department concerning the data being collected.

3.2 Installation Plan: The installation plan shall include as a minimum the following information:
The Contractor shall submit the Specification sheet for the proposed VW-DCC system for review and approval by the Engineer.

Submit locations where VW-DCC will be installed.

Proposed installation method.

Proposed method to protect VW-DCC during construction from construction equipment, vandalism, weather.

3.3 Submittal Reviews: Approval of the personnel qualification and installation plan by the Department shall not relieve the Contractor of its responsibility to successfully install the VW rod extensometers and VW piezometers and monitor this instrumentation with VW-DCC in accordance with the plans and specifications. Approval by the Department of the VW-DCC installation plan shall be contingent upon satisfactory demonstration that the VW-DCC is meeting the objectives of the Department's Geotechnical Instrumentation Monitoring Plan. If, at any time, the Department or the Engineer considers that the VW-DCC does not produce satisfactory results, the Contractor shall alter the method and/or equipment as necessary to comply with the Special Provisions and Department's Instrumentation Plan. The Department will be the sole judge in determining the adequacy of the Contractor's VW-DCC.

4.0 Delivery, Storage, and Handling. The Contractor shall check all materials and equipment upon delivery to ensure that the proper items are received and are not damaged. All materials shall be stored and maintained in a clean, uncontaminated condition throughout the course of the project. Upon receipt of the VW-DCC, the Contractor shall submit copies of the manufacture's installation and instruction manual for review and approval by the Engineer, and shall make available the data logging system for inspection by the Engineer.

5.0 Abandonment of VW-DCC. Once the Engineer has determined that VW-DCC systems have served their purpose and are no longer needed, the VW-DCC shall be abandoned by removing all equipment and signal wires a minimum of 2 feet of ground surface.

6.0 Method of Measurement. The number of VW-DCC provided in the plans, will be paid for at the contract unit price bid for "Vibrating Wire Data Collection Center" which shall include, but not limited to, all labor, materials, and equipment necessary to install a vibrating wire data collection center. Payment will not be made for VW-DCC that malfunction or are rejected for their inability to perform, or do not meet the requirements in the plans and these specifications.

7.0 Basis of Payment. The price and payment for this work shall be full compensation for furnishing the necessary data logging system, enclosure, protection from vandalism and construction equipment, and incidental items based on the successful implementation of the VW-DCC system.

Payments shall be made under:

Item No.	Pay Item	Pay Unit
8990440	VW Data Collection Center	EA

(84) DIVISION 200: VIBRATING WIRE ROD EXTENSOMETER

1.0 Description. This work includes furnishing all supervision, materials, equipment, labor, and related services necessary for providing, installing and maintaining a Vibrating Wire Rod Extensometer (VWRE) at the locations indicated in the plans and in accordance with these specifications. This item includes the furnishing of as-built drawings of actual locations where instrumentation was installed, survey data recorded during instrumentation installation, and installation field reports. Also included in this item of work is the initial and periodic/continuous recording of VWRE readings and reporting to the Engineer in accordance with the Department's Geotechnical Instrumentation Monitoring Plan for the entire duration of the project.

The purpose of the instrumentation monitoring program is to monitor settlement of the approach embankments.

The Contractor shall be familiar with project geotechnical conditions and recognize that geotechnical data is available with geotechnical boring logs, laboratory testing results, and other pertinent information.

2.0 Vibrating Wire Rod Extensometer. The Vibrating Wire Rod Extensometer is an automated device for monitoring settlement. The VWRE shall contain 6 rod extensometers that will measure settlement at different depths below the ground surface. The depths of data collection are indicated in the project plans. The rod extensometers will be housed in a casing of sufficient diameter to allow for 6 rods in each casing. The VWRE shall be capable of measuring settlements of 18 inches. The VWRE shall have an accuracy ± 0.1 percent with a thermal effect of < 0.05 percent for a temperature range of -4°F to 176°F . In addition, the VWRE shall have a long-term stability of < 0.2 percent per year. The location of each rod extensometer cluster is indicated in the project plans. Each rod extensometer cluster will be connected to a data collection center. The cluster shall be installed in accordance with the manufacturer's recommendations. Each VWRE cluster shall be connected to the data collection center either via cable or via cellular communications. If cable is used, enough cable shall be provided to run from the VWRE to the location of the Vibrating Wire Data Collection Center (VW-DCC) plus 10 feet for each instrument. The cable used to connect the VWRE to the VW-DCC shall meet the requirements of the instrument manufacturer/supplier. The Contractor shall supply non-conductive conduit to encase the cable between the VWRE and VW-DCC. The conduit shall have a minimal nominal diameter of 1 inch and meet the requirements of Schedule 80 materials. Provide enough conduit to enclose all lengths of buried cable from the VWRE to the VW-DCC. All connections in the conduit and in the cable between the VWRE and VW-DCC shall be water proof.

3.0 Submittals. Within 30 calendar days before installing the VWRE, the Contractor shall submit to the Department for review the personnel qualification, installation plan, and monitoring plan. The submittals shall contain as a minimum the following information.

3.1 Qualifications: The Contractor shall identify the licensed surveyor who shall be responsible for providing survey services during the installation of the VWRE. The Contractor shall identify the geotechnical engineer that will be responsible for installing and maintaining the VWRE. The same geotechnical engineer that is responsible for the VW-DCC and piezometers will also be responsible for the VWRE. The geotechnical engineer's experience in installing VWRE in accordance with the plans and Contract Documents shall be documented by providing a project summary, of at least three projects, that includes for each project the project name, role in providing instrumentation services, type of VWRE, equipment used, duration of the project (i.e. dates), magnitude of settlements, client name and address, name and phone number of representative of the consultant and owner for whom the work was performed and can attest to the successful completion of the work, and any other information relevant to demonstrating the geotechnical engineer's qualifications. In addition, the manufacturer/supplier shall also be on-site during the initial installation of the VWRE to ascertain that all instruments have been connected correctly. The manufacturer/supplier shall also be available for questions from either the geotechnical engineer responsible for maintaining the VWRE or from the Department concerning the data being collected.

EXHIBIT 5 - SPECIAL PROVISIONS

3.2 Installation Plan: The installation plan shall include as a minimum the following information:

5. The Contractor shall submit the Specification sheet for the proposed VWRE system for review and approval by the Engineer.
6. Submit locations where VWRE will be installed if different from the location shown on the plans.
7. Proposed installation method.
8. Proposed method to protect VWRE during construction from construction equipment, vandalism, weather.

3.3 Submittal Reviews: Approval of the personnel qualification and installation plan by the Department shall not relieve the Contractor of its responsibility to successfully install the VWREs in accordance with the plans and specifications. Approval by the Department of the VWRE installation plan shall be contingent upon satisfactory demonstration that the VWRE is meeting the objectives of the Department's Geotechnical Instrumentation Monitoring Plan. If, at any time, the Department or the Engineer considers that the VWRE does not produce satisfactory results, the Contractor shall alter the method and/or equipment as necessary to comply with the Special Provisions and Department's Instrumentation Plan. The Department will be the sole judge in determining the adequacy of the Contractor's VWRE.

4.0 Delivery, Storage, and Handling. The Contractor shall check all materials and equipment upon delivery to ensure that the proper items are received and are not damaged. All materials shall be stored and maintained in a clean, uncontaminated condition throughout the course of the project. Upon receipt of the VWRE, the Contractor shall submit copies of the manufacturer's installation and instruction manual for review and approval by the Engineer, and shall make available the data logging system for inspection by the Engineer.

5.0 VWRE Installation. Upon receipt of the VWRE, the Contractor shall submit copies of calibration sheets and the manufacturer's installation and instruction manual for review and approval by the Engineer, and shall make available the VWRE for inspection by the Engineer.

The Contractor shall notify the Engineer at least fourteen (14) days prior to the installation of VWRE. The VWREs shall be furnished and installed by the Contractor in accordance with the plans and this specification and in the presence of the Engineer.

The Contractor shall be responsible for locating all VWREs in the field and ensuring that no conflicts exist between VWREs and foundations, structures, utilities or other construction proposed or present at the site.

The Contractor shall provide a licensed surveyor to stake out and provide as-built locations and elevations of all VWREs locations.

VWREs shall be installed prior to construction of the embankment. VWRE installation shall be in accordance with the manufacturer's recommendations as presented in their instruction and installation manual. The VWRE will be connected to the VW-DCC in accordance with the plans, contract documents, and manufacturer's recommendations.

The Contractor shall accurately locate all VWREs in accordance with the plans. VWREs may be adjusted by the Contractor, with the approval of the Engineer, to avoid utilities, foundations, and all other underground construction.

Within 1 week following installation, the contractor shall submit an installation record for each VWRE, which includes the instrumentation identification as provided in the plans, station/alignment, offset, and elevation. The VWRE shall be located to an accuracy of 0.01 ft (both vertically and horizontally).

The Contractor shall protect VWRE locations from damage and vandalism for the duration of the Contract and repair or replace damaged or inoperative VWREs at no cost to the Department.

EXHIBIT 5 - SPECIAL PROVISIONS

6.0 Abandonment of VWRE. Once the Engineer has determined that the VWRE systems have served their purpose and are no longer needed, the VWRE systems shall be abandoned in-place. The Contractor shall remove recoverable portions of the VWRE. All recoverable instrumentation shall remain property of the Contractor. The Contractor shall remove no more than 2 feet of the conduit that extends into the embankment and shall seal the conduit left in place within the embankment using a lean grout mix.

7.0 Method of Measurement. The number of VWRE provided in the plans, will be paid for at the contract unit price bid for "Vibrating Wire Rod Extensometer" which shall include all equipment, including but not limited to the VWRE, water proof casing; mobilization; labor; surveys; materials; incidentals and abandonment required by these Specifications along with VWRE data as outlined in the Geotechnical Instrumentation and Monitoring Plan. Payment will not be made for VWRE that malfunction or are rejected for their inability to perform, or do not meet the requirements in the plans and these specifications.

8.0 Basis of Payment. The price and payment for this work shall be full compensation for furnishing the necessary data logging system, enclosure, protection from vandalism and construction equipment, data as outlined in the Geotechnical Instrumentation and Monitoring Plan, and incidental items based on the successful implementation of the VWRE system.

Payments shall be made under:

Item No.	Pay Item	Pay Unit
2038140	Mon. Device - Vibrating Wire Rod Extensometers	EA

(85) DIVISION 700: AXIAL O-CELL LOAD TESTING OF DRILLED SHAFTS

1. DESCRIPTION

This work shall consist of furnishing all materials, equipment, labor, and incidentals necessary for conducting axial load testing of one drilled shaft. Axial load tests shall be performed as shown on the plans.

The axial testing shall be performed using two levels of Osterberg-Cells. The Contractor will be required to supply material and labor as necessary to prepare for and perform the load test and to restore the site once the load test is completed. The drilled shaft used for the load test program will be instrumented by LOADTEST, Inc. (the Osterberg Cell supplier). The Contractor shall subcontract with LOADTEST, Inc. to supply the Osterberg-Cells and other necessary equipment and instrumentation, perform the test, and analyze the results of one axial load test on one test shaft. Immediately prior to the placement of the reinforcement cage, the shaft dimensions and verticality shall be determined using a soniCaliper system, as provided and operated by LOADTEST, Inc.

The Osterberg cell equipment shall have sufficient capacity to fully mobilize the test shafts' ultimate capacity. The applied load shall at least be equivalent to the test shaft load specified in the plans.

2. ORDER OF ACTIVITIES

For the test shaft, proposed instrumentation location shall be provided to the Department a minimum of 7 days prior to the fabrication of the shaft reinforcement cage. The Department will provide comments for the final instrumentation locations within 3 days after receiving this information.

Strain and pressure gage instrumentation, displacement transducers, CSL access tubes, O-cells

EXHIBIT 5 - SPECIAL PROVISIONS

and any other materials and equipment required by LOADTEST, Inc. shall be installed on the reinforcing cage.

Immediately prior to placement of the reinforcement cage, the dimensions and verticality of the drilled shaft excavation shall be determined by LOADTEST, Inc. using the soniCaliper system.

CSL testing will be performed by the Department personnel or a Department designated representative in accordance with Section 727 of the Standard Specifications. CSL logging will be performed between a minimum of 3 days and a maximum of 7 days after concrete placement provided the concrete has attained a compressive strength of at least 3,000 psi during this period.

The axial Osterberg-Cell (O-cell) testing shall not begin until at least 4 days after CSL testing and until the concrete has attained a compressive strength of 4,000 psi. With approval of the Engineer, high early strength concrete may be used to obtain this strength at an earlier time to prevent testing delays.

The Contractor shall cooperate with the Department's personnel whom shall be granted access to all facilities necessary for observation of the test and the viewing of the test results.

3. SUBMITTALS

The Contractor shall submit to the Department for approval three (3) sets of shop drawings, erection plans, test calculations and details associated with the axial O-cell testing within 21 days following the Notice to Proceed. The submittal shall include details with respect to the reinforcement cage fabrication, instrumentation plans, reference beams and movement measuring systems. All details, drawings, calculations, and procedures shall be submitted to the Department for review a minimum of 21 days prior to beginning the axial load test. Approval of this submittal by the Department shall not relieve the Contractor from making subsequent changes that may become necessary to carry out the test.

4. MATERIALS

The Contractor shall supply all materials required to install the Osterberg cell, conduct the load test, and remove the load test apparatus as required.

The Contractor shall furnish two (2) Osterberg Cell assemblies as required for the test shaft, to be supplied by:

LOADTEST, Inc. 2631-D NW 41st Street Gainesville, FL 32606
Phone: **(800) 368-1138**, (352) 378-3717, Fax: (352) 378-3934

The Osterberg cell assemblies to be provided shall have a capacity that fully mobilizes the test shafts' ultimate capacity and shall be equipped with all necessary hydraulic lines, fittings, pressure source, pressure gage and telltale devices.

Additional materials required include, but are not limited to, the following:

- Fresh, clean, potable water from an approved source to be used as hydraulic fluid to pressurize the Osterberg Cell(s).
- Materials sufficient to construct and shade a stable reference beam system for monitoring movements of the shaft during testing. The system shall be supported at a minimum distance of 3 shaft diameters from the center of the test shaft to minimize disturbance of the reference system. A tripod shall be provided to support an automated digital survey level used to monitor movement of the reference system during testing. Alternatively, two survey levels located in excess of three shaft diameters may be used to monitor the top of shaft displacement in lieu of the beam. In this case, two tripods and weather protection (Quikshade) shall be provided.

EXHIBIT 5 - SPECIAL PROVISIONS

- Materials sufficient to construct a protected work area (including provisions such as a tent or shed for protection from inclement weather for the load test equipment and personnel) of size and type required by the Engineer and LOADTEST, Inc. In the case of cold weather, the protected work area shall be maintained at a temperature above 40° F in order to insure proper operation of the load testing equipment.
- Stable electric power source, as required for lights, welding, instruments, etc.
- Materials such as angle or channel iron, steel bearing plates and/or other devices needed to attach O-cell assembly to rebar cage or carrying frame, as required.

Materials supplied which do not become a part of the finished structure become the property of the Contractor at the conclusion of the load test and shall be removed from the job site.

5. EQUIPMENT

The Contractor shall supply equipment required to install the Osterberg cells, conduct the load tests, and remove the load test apparatus as required. Equipment required includes but is not limited to:

- Welding equipment and certified welding personnel, as required, to assemble the test equipment under the supervision of LOADTEST, Inc. attach hydraulic fittings and telltales to the Osterberg cells, and prepare the work area.
- Equipment and labor to construct the reinforcing steel cage and/or placement frame required for the test shaft, including steel bearing plates as required.
- Equipment and operators for handling the Osterberg cells and instrumentation and placement frame or reinforcing steel cage during the installation of the Osterberg cells and during the conduct of the test, including but not limited to a crane or other lifting device for Osterberg cells and instrumentation, manual labor, and hand tools as required by LOADTEST, Inc.
- Equipment and labor sufficient to erect the protected work area and monitoring reference beam system, to be constructed to the requirements of the Engineer and LOADTEST, Inc.
- Air compressor (minimum 150 cfm) for pump operation during load testing.
- Strain Gauges – the Contractor shall supply the number of strain gauges as required at each level. The number of strain gauges will be determined by the Contractor after consultation with Loadtest, inc., and as approved by the Department. All cost for supplying strain gauges will be included in the price bid for Axial Load Test with Osterberg Load Cell, and no additional payment will be made for this equipment.

6. PROCEDURE

The Contractor shall perform the drilled shaft excavation in accordance with Section 712 of the Standard Specifications.

The Osterberg Cells, hydraulic supply lines and other instruments will be assembled and made ready for installation under the direction of LOADTEST, Inc. and the Department, in a suitable area, adjacent to the test shaft, to be provided by the Contractor. The Osterberg Cell assemblies shall be welded to the rebar cage or carrying frame. The plane of the bottom plate(s) of the O-cell(s) shall be set at right angles to the long axis of the cage. The Contractor shall use the utmost care in handling the test assembly so as not to damage the instrumentation during installation. The contractor shall limit the deflection of the cage to two (2) feet between pick points while lifting the cage from the horizontal position to vertical. The maximum spacing between pick points shall be 25 feet. The contractor shall provide support bracing, strong backs, etc. to maintain the deflection within the specified tolerance. The O-cell assemblies must remain perpendicular to the long axis of the reinforcing cage throughout the lifting and installation process.

When the test shaft excavation has been completed, inspected, callipered using the soniCaliper equipment and accepted by the Department, the O-cell assembly and the reinforcing steel may be installed. A seating layer of concrete shall be placed in the base of the shaft to provide a level

base and reaction for the lower O-cell assembly. The seating layer shall be placed using a pump line or tremie pipe extending through the O-cell assemblies to the base of the shaft. After seating the Osterberg cell assembly, the remainder of the drilled shaft shall be concreted in a manner similar to that specified for production shafts. At least four (4) concrete test cylinders, in addition to those specified elsewhere, shall be made from the concrete used in the test shaft, to be tested at the direction of LOADTEST, Inc. At least one of these test cylinders shall be tested prior to the load test and at least two cylinders shall be tested on the day of the load test.

During the load test, no casings may be vibrated into place in the foundation area, within a 100 ft radius of the load test. Drilling may not continue within a 100-foot radius of the test shaft. If test apparatus shows any interference due to construction activities outside of this perimeter, such activities shall cease immediately.

After the completion of the load test, and at the direction of the Department, the Contractor shall remove any equipment, material, waste, etc. which are not to be a part of the finished structure.

7. LOAD TESTING AND REPORTING

The load testing shall be performed by a qualified geotechnical engineer approved in advance by the Department. The geotechnical engineer must have a demonstrated knowledge of load testing procedures, and have performed at least 10 Osterberg cell load tests within the past two years. The load testing shall be performed in general compliance with *ASTM D 1143 Standard Test Method for Piles Under Static Axial Load* using the Quick Load Test Method for Individual Piles. Initially the loads shall be applied in increments equaling 5 to 10% of the anticipated ultimate capacity of the test shaft. The magnitude of the load increments may be increased or decreased depending on the project requirements but should not be changed during the test. Direct movement indicator measurements should be made of the following: O-cell expansion either directly or with telltales (minimum of 3 indicators required), upward top-of-shaft displacement (minimum of 2 indicators required) and shaft compression above O-cell (minimum of 2 indicators required). Loads shall be applied in three stages by: 1) pressurizing the lower O-cell while the upper assembly remains closed, 2) pressurizing the upper O-cell while the lower O-cell is allowed to freely drain and 3) pressurizing the upper O-Cell while the hydraulics are closed on the lower O-cell. Loads shall be applied at the prescribed intervals until the ultimate capacity of the shaft is reached in either end bearing or side shear, until the maximum capacity or maximum stroke of an O-cell is reached, or unless otherwise directed by the Department. At each load increment, or decrement movement indicators shall be read at 1, 2, 4 and 8-minute intervals while the load is held constant. During unloading cycles the load decrement shall be such that at least 4 data points are acquired for the load versus movement curve. Additional cycles of loading and unloading using similar procedures may be required by the Department following the completion of the initial test cycle. Displacement sensors used to measure O-cell expansion and top-of-shaft displacement should have a minimum travel of 4 inches and be capable of being read to the nearest 0.001 inch division. When O-cell expansion is measured directly, LVWDTs capable of measuring the full stroke of the Osterberg Cell will be used (typically 6 inches). Displacement sensors used to measure shaft compression should have a minimum travel of 1 inch and be capable of being read to the nearest 0.001 inch division.

Unless otherwise specified by the Department, the Contractor will supply four (4) paper copies of a report of each load test, as prepared by LOADTEST, Inc. and a PDF electronic copy. An initial data report containing the load-movement curves and data tables will be provided to the Department within 3 working days of the completion of load testing, to allow evaluation of the test results. A final report on the load testing shall be submitted to the Department within 7 working days after completion of the load testing.

8. METHOD OF PAYMENT

The Axial Drilled Shaft Load Tests shall be considered as any material, labor, equipment, load cells, etc. required above the requirements of production drilled shaft installation necessary to

EXHIBIT 5 - SPECIAL PROVISIONS

install, conduct, and remove the drilled shaft load test at the direction of the Department and LOADTEST Inc. representative. All costs of the axial load test including subcontracting to LOADTEST Inc. will also be included in the price bid for this work.

All costs associated with the normal production of the drilled shaft are measured and paid for elsewhere in the contract documents.

9. DISPOSITION OF TEST SHAFT

After completion of all testing and the submittal of the required reports, the test shaft shall be cut-off at a depth of 1 ft below the ground surface. The cut-off portion of the shaft shall be properly disposed of by the contractor and the resulting hole shall be backfilled with soil in accordance with Section 205 of the Standard Specifications. The test area shall be graded smooth.

10. BASIS OF PAYMENT

The complete and accepted "Drilled Shaft Osterberg Cell Load Tests" shall be paid for at the contract lump sum price for each. This shall constitute full compensation for all costs incurred during the procurement, installation, conducting of the test, and subsequent removal of test apparatus and appurtenances.

11. PAYMENT

Payments shall be made under SCDOT Pay Item No. 8990181, Axial Load Test with Osterberg Cell Load".

(86) DIVISION 700: APPLE LOAD TESTING

April 18, 2013

1.0 GENERAL

This work shall consist of performing high-strain dynamic testing using the APPLE dynamic loading system on a test shaft for the purpose of determining and/or verifying the ultimate bearing capacity of the production shafts. Production shaft lengths may be adjusted after results of the test shaft have been analyzed. No materials shall be ordered until shaft lengths are approved by the Department. The test shaft depth, diameter, and location shall be as specified in the plans. The testing specified in the project documents shall be conducted in general accordance with ASTM D4945 and this Special Provision.

The APPLE Load Testing equipment shall have sufficient capacity to fully mobilize the test shafts' ultimate capacity. The applied load shall at least be equivalent to the test shaft load specified in the plans.

The location of the test shaft (non-production) shall be as indicated in the plans. The test shaft shall maintain a minimum distance of 25 feet from any foundation element of any future bent. The Contractor shall submit the proposed location to the Department for approval.

Load testing of the test shaft shall not begin until the concrete has attained a compressive strength of no less than 4,000 psi and had a curing time of no less than 7 days. High early strength concrete may be used to obtain the required strength at an earlier time to prevent testing delays, upon the approval of the Department.

The Contractor will be required to furnish and include all costs in the bid item for all materials, personnel, and equipment as described in the plans and Special Provisions and as required by the Contractor to adequately perform the APPLE Load Test. The Contractor shall engage the services of an approved APPLE supplier for instrumenting, performing, and reporting of the load

EXHIBIT 5 - SPECIAL PROVISIONS

test. The Contractor must provide a minimum of 45 days notice to the APPLE supplier before the load testing. An approved APPLE supplier may be contacted at:

GRL Engineers, Inc., 9912 Colvard Circle, Charlotte, NC 28269
Phone: (704) 593-0992, Fax: (704) 593-0993

The Contractor shall submit to the Department for approval 3 sets of shop drawings, erection plans, and test calculations and details. The Contractor should include details with respect to the movement measuring system and the method for measuring the applied load. The Contractor shall also submit details and shop drawings of the proposed set up for review by the Department 2 weeks prior to beginning construction of the testing arrangements (including the test shaft). All details, drawing calculations, and procedures shall be submitted to the Department for review a minimum of 2 weeks prior to beginning the APPLE Load Test. Approval of these submittals by the Department shall not relieve the Contractor from making subsequent changes that may become necessary to carry out the test.

The Contractor, in cooperation with the APPLE supplier will supply and supervise the mobilization, assembly, and operation of the APPLE Load Test equipment. APPLE supplier will provide and install the required instrumentation for the test shaft, acquire the test data during testing, and culminate the APPLE data into a report. The report will be presented to the Contractor and the Department for evaluation. Interpretation of the test data with regard to foundation recommendations will be performed by the Department.

2.0 MATERIALS & EQUIPMENT

The APPLE supplier will supply all materials, personnel and equipment as described below and as required by the Contractor and the APPLE supplier to adequately perform the APPLE Load Test. Such materials and equipment are:

1. APPLE dynamic loading system and all items specifically incidental to the APPLE test system.
2. Means to insure flat, level (axial to test shaft), and solid concrete shaft top.
3. A drop weight of no less than 20 tons. The impacting surface of the drop weight should have an area between 70 and 130 percent of the test shaft top area. The cross-sectional shape of the drop weight shall be as regular as possible (square, round, hexagonal, etc.).
4. A guiding frame allowing variable drop heights typically between 3 and 7 feet, or as determined by the APPLE Testing Engineer (described herein at Testing Engineer) in consultation with the Department.
5. A top cushion consisting of new sheets of plywood with a total thickness of 2 to 6 inches, or as determined by the Testing Engineer in consultation with the Department.
6. A surveyor's transit, laser light or equivalent for measurements of test shaft set under each drop weight impact.
7. Dynamic testing shall be performed and/or supervised by a Licensed Professional Engineer in South Carolina with at least two years of dynamic testing experience.
8. Final Report of APPLE Load Testing no later than 14 days after all APPLE Load Testing is completed and accepted by the Department. Field results of the APPLE Load Test will be provided within 72 hours of test completion.

The Contractor shall supply any additional equipment and personnel to assemble, perform,

EXHIBIT 5 - SPECIAL PROVISIONS

disassemble, and move to next test site (if applicable). This equipment includes, but not be limited to, the following:

1. Unloading and loading of the APPLE trucks during mobilization and demobilization.
2. Any necessary on-site mobilization of test equipment.
3. A level and firm surface surrounding the test shaft to support the APPLE testing system.
4. A level and smooth shaft top. The top of the test shaft shall incorporate permanent casing length as indicated in the plans and have a minimum ½-inch wall thickness. There shall be at least 6 inches between the top of the test shaft and the top of the casing left in place.
5. A crane, rigging and operator capable of lifting, unloading, assembling, disassembling, and packing all APPLE equipment. The crane and rigging should be of sufficient size and strength to handle the required APPLE equipment.
6. Power source adequate for electronic equipment.
7. For over water tests only, welding equipment and welder for falsework platform.

3.0 PREPARATION FOR TESTING

Notification of the requirement for an APPLE Load Test shall be provided by the Contractor to the Department at least 45 days in advance of the test. The Contractor shall perform site and foundation preparation. Foundation preparation includes the cutting and cleaning of the surface of the test shaft down to test elevation. The top of the test shaft shall be smooth and level. The area around the test shaft, on land, should be leveled and compacted within a 15 foot radius. The top of shaft should be approximately 6 feet above grade for axial testing. For over water or elevated work areas, the area provided must be level and at the test elevation. The support falsework platform shall be assembled and installed by the Contractor at the test location.

Prior to performing the load test, the Testing Engineer must be provided with soil boring logs, test shaft installation records, concrete properties (strength, etc.) and details regarding the anticipated dynamic loading equipment. The Testing Engineer is required to perform wave equation analyses (using GRLWEAP or equivalent) to determine the suitability of the proposed dynamic load testing equipment and an acceptable range of drop weight heights so as not to cause damage in the test shaft during the test.

4.0 PROCEDURE FOR APPLE LOAD TESTING

The Contractor shall assist the Testing Engineer as necessary during all aspects of the APPLE Load Test. The following steps shall be taken in the performance of the APPLE Load Test.

1. Preparation for testing as described in Section 3.0.
2. Prior to testing, the Contractor shall make the upper 6 feet of the test shaft completely accessible to the Testing Engineer.
3. Four “windows” (approximate size of 6 by 6 inches) diametrically opposite of each other shall be located and removed from the casing, if appropriate, or an entire band of the casing removed to expose a smooth concrete surface for attachment of the sensors. Sensors are typically attached at least one diameter below the shaft top. Sensor locations will be determined by the Testing Engineer.
4. In areas where casing is not present, the Testing Engineer, or Contractor under the direction of the Testing Engineer, shall smooth (by grinding) areas around the test shaft circumference such that proper sensor attachment can be accomplished.

EXHIBIT 5 - SPECIAL PROVISIONS

5. Sensors shall be attached by the Testing Engineer or under the direction of the Testing Engineer to the exposed concrete in a secure manner as to prevent slippage under impact.
6. Shaft top should be examined to insure having a smooth level surface.
7. Survey and record the shaft top elevation to a bench mark.
8. Apply plywood cushion and striker plate to the shaft top.
9. Two to four hammer impacts with varying drop heights should be applied to the top of the shaft. The first drop height should be minimal to allow the Testing Engineer to assess the testing equipment, the driving system and stresses on the shaft. Subsequent impacts can then be applied by utilizing sequentially higher drop heights until either stresses in the shaft are excessive or the shaft permanent set for the applied impact exceeds 0.1 inch.

5.0 INSTRUMENTATION

The intent of the load test instrumentation is to measure the test load and its distribution between side friction and end bearing, load versus deflection, to provide information for design calculations and estimates, and to provide information for final design. The Contractor shall provide assistance when requested by the Testing Engineer during installation of any instrumentation supplied through this contract.

The cost of all instrumentation, to be installed as directed by the APPLE supplier, shall be included in the cost for APPLE Load Testing. Instrumentation pertaining to the APPLE testing, and listed below, shall be provided by the APPLE supplier in addition to any instrumentation outlined in ASTM D 4945.

1. Pile Driving Analyzer[®] (PDA) manufactured by Pile Dynamics, Inc., model PAK, PAX or PAL or equivalent.
2. Four calibrated strain transducers.
3. Four calibrated accelerometers.

6.0 REPORTING OF RESULTS

It is the APPLE supplier's responsibility to submit a Final Report of APPLE Load Testing no later than 14 days after all APPLE load testing is completed and accepted by the Department. Field results of the APPLE Load Test shall be provided within 72 hours of test completion. In addition to the field results, results from a CAPWAP[®] analysis or equivalent shall be submitted. A CAPWAP[®] analysis shall be completed for each hammer impact in the field and shall be performed by an Engineer that has achieved Advanced Level or better on the Foundation QC High Strain Dynamic Pile Testing Examination. The report must also provide the following:

1. Wave Equation analysis results obtained prior to testing.
2. CAPWAP[®] (or equivalent) analysis results.
3. The maximum measured force, maximum calculated tension force, transferred energy to the sensor location, corresponding stresses, and the Case Method bearing capacity for each impact.
4. Assessment of the test results both with respect to pile capacity and integrity.

7.0 METHOD OF MEASUREMENT

The quantity of the pay item "Drilled Shaft Axial Load Test is measured by each (EA) APPLE Load Test completed and accepted by the Department. A completed APPLE Load Test shall be one test conducted on a shaft using the APPLE dynamic loading system and meeting +/-15% of, or exceeding the target APPLE test peak load as specified in the plans and Special Provisions.

The APPLE Load Test shall be considered as any material, labor, equipment, instrumentation, etc. required above. This item should include everything necessary to assemble, install, perform, collect data, and remove the APPLE Load Test equipment; under the direction of the APPLE supplier and others.

8.0 DISPOSITION OF TEST SHAFT

After all testing and data collection has been completed, the test shaft shall be cut off to a minimum depth of 5 feet below the ground surface. It shall be the Contractor's responsibility to dispose of the cut off section of the test shaft.

9.0 BASIS OF PAYMENT

APPLE Load Testing will be paid for at the contract bid price per each accepted test. The price and payment shall be considered full compensation for furnishing all materials, providing all tools, equipment, labor and incidentals, providing assistance to the production of the test shaft, performing the APPLE Load Test, and disposing of the test shaft as described in Section 8.0 above.

10.0 PAYMENT

Payment shall be made under SCDOT Pay Item No. 7120166, "Drilled Shaft Axial Load Test".

(87) DIVISION 700: STATNAMIC LOAD TESTING

1.0 GENERAL

This work shall consist of performing a Statnamic axial compression load test on a test shaft for the purpose of determining and/or verifying the ultimate bearing capacity of the production shafts. Production shaft lengths may be adjusted after results of the test shaft have been analyzed. No materials shall be ordered until shaft lengths are approved by the Department. The test shaft depth, diameter, and location shall be as specified in the plans. The testing specified in the project documents shall be conducted in general accordance with ASTM D7383-08 and this Special Provision.

The Statnamic Load Testing equipment shall have sufficient capacity to fully mobilize the test shafts' ultimate capacity. The Statnamic load shall at least be equivalent to the test shaft load specified in the plans.

The location of the test shaft (non-production) shall be as indicated in the plans. The test shaft shall maintain a minimum distance of 25 feet from any foundation element of any future bent. The Contractor shall submit the proposed location to the Department for approval.

Load testing of the test shaft shall not begin until the concrete has attained a compressive strength of no less than 4,000 psi and had a curing time of no less than 7 days. High early strength concrete may be used to obtain the required strength at an earlier time to prevent testing delays, upon the approval of the Department.

EXHIBIT 5 - SPECIAL PROVISIONS

The Contractor will be required to furnish and include all costs in the bid item for all materials, personnel, and equipment as described in the plans and Special Provisions and as required by the Contractor to adequately perform the Statnamic load test. The Contractor shall engage the services of an approved Statnamic supplier for instrumenting, performing, and reporting of the load test. The Contractor must provide a minimum of 45 days notice to the Statnamic supplier before the Statnamic testing. If strain instrumentation is utilized, a minimum of 45 days notice shall be given to the Statnamic supplier before the test shaft construction to allow for instrumentation installation. An approved Statnamic supplier may be contacted at:

Applied Foundation Testing, Inc. 4035 J. Louis Street, Green Cove Springs, FL 32043
Phone: (904) 284-1337, Fax: (904) 284-1339

The Contractor shall submit to the Department for approval 3 sets of shop drawings, erection plans, and test calculations and details. The Contractor should include details with respect to the movement measuring system, the piston support system, and the method for measuring the applied load. The Contractor shall also submit details and shop drawings of the proposed set up for review by the Department 2 weeks prior to beginning construction of the testing arrangements (including the test shaft). All details, drawing calculations, and procedures shall be submitted to the Department for review a minimum of 2 weeks prior to beginning the Statnamic load test. Approval of these submittals by the Department shall not relieve the Contractor from making subsequent changes that may become necessary to carry out the test.

The Contractor, in cooperation with the Statnamic supplier will supply and supervise the mobilization, assembly, and operation of the Statnamic load test equipment. Statnamic supplier will provide and install the required instrumentation for the test shaft, acquire the test data during testing, and culminate the Statnamic data into a report. The report will be presented to the Contractor and the Department for evaluation. Interpretation of the test data with regard to foundation recommendations will be performed by the Department. Statnamic testing is non-destructive and entails no greater danger of shaft damage than static load testing.

2.0 MATERIALS

The Statnamic supplier will supply all materials, personnel and equipment as described below and as required by the Contractor and the Statnamic supplier to adequately perform the Statnamic load test. Such materials and equipment are:

9. Statnamic apparatus, including pressure chamber and cylinder, reaction masses, exhaust silencer, gravel structure, gravel structure base frame, and all items specifically incidental to the Statnamic test system.
10. Foundation top plate (and follower assembly, if needed), adequate to distribute the applied Statnamic test load to the test shaft.
11. Statnamic load, acceleration transducers, and data acquisition system pertaining directly to the Statnamic device. All required electronic equipment for the recording, processing, and storage of the Statnamic test will be operated by the Statnamic supplier.
12. Resistance based strain gages and sufficient cabling (if required).
13. One Geotechnical Engineer and one technician experienced in the implementation of the Statnamic test methods who will direct the test setup, perform the testing, direct the disassembly of the test apparatus, provide load test submittals, provide assistance as needed with pertinent Statnamic issues, and provide a written report.
14. Final Report of Statnamic Load Testing no later than 14 days after all Statnamic load testing is completed and accepted by the Department. Field results of the Statnamic load test will be provided within 72 hours of test completion.

EXHIBIT 5 - SPECIAL PROVISIONS

Additional materials required for the Statnamic load test shall be supplied by the Contractor as specified by the Statnamic supplier and include, but are not limited to, the following:

1. Support piles for falsework platform. A falsework platform is not required for land based testing. However, materials such as crane mats and plywood may be necessary to provide a level and firm surface to assemble the Statnamic device on land based testing.
2. $\frac{3}{4}$ inch (19 mm) clear gravel with less than 5 percent fines, 105 cubic yards (81 cubic meters) per test. The gravel material must be approved by the Department. (Note that #67 Stone has been used successfully in the past.)
3. Statnamic load, acceleration transducers, and data acquisition system pertaining directly to the Statnamic device. All required electronic equipment for the recording, processing, and storage of the Statnamic test will be operated by the Statnamic supplier.

3.0 EQUIPMENT

The Contractor shall supply any additional equipment and personnel to assemble, perform, disassemble, and move to next test site (if applicable). This equipment includes, but not be limited to, the following:

8. Unloading and loading of the Statnamic trucks during mobilization and demobilization.
9. Any necessary on-site mobilization of test equipment.
10. A level and firm surface surrounding the test shaft to support the Statnamic device.
11. A level and smooth shaft top. The top of the test shaft shall incorporate permanent casing length as indicated in the plans and have a minimum $\frac{1}{2}$ -inch wall thickness. There shall be at least 6 inches between the top of the test shaft and the top of casing left in place.
12. A crane, rigging and operator capable of lifting, unloading, assembling, disassembling, and packing all Statnamic equipment. The crane and rigging should be of sufficient size and strength to handle the required Statnamic equipment.
13. Power source adequate for electronic equipment.
14. For over water tests only, welding equipment and welder for falsework platform.

4.0 PREPARATION FOR TESTING

Notification of the requirement for a Statnamic load test shall be provided by the Contractor to the Department at least 45 days in advance of the test. The Contractor shall perform site and foundation preparation. Foundation preparation includes the cutting and cleaning of the surface of the test shaft down to design or test elevation. The top of the test shaft shall be smooth and level. The area around the test shaft, on land, should be leveled and compacted within a 15 foot radius. The top of shaft should be approximately 2 feet above grade for axial testing. For over water or elevated work areas, the area provided must be level and at the test elevation. The support falsework platform shall be assembled and installed by the Contractor at the test location.

5.0 PROCEDURE FOR AXIAL STATNAMIC LOAD TESTING

The Contractor shall assist the Statnamic supplier as necessary during all aspects of the Statnamic Load Test. The following steps shall be taken in the performance of the Statnamic Load Test.

10. Preparation for testing as described in Section 4.0.

EXHIBIT 5 - SPECIAL PROVISIONS

11. Place the piston mounting plate on the center of the test shaft, level the plate and secure with anchor bolts or welding.
12. Survey and record the shaft top elevation to a bench mark.
13. Bolt the piston assembly to the piston mounting plate.
14. Set the base frame for the gravel containment structure.
15. Connect load cell cable, ignition cable, and accelerometers to piston.
16. Connect all instrumentation to the data acquisition system.
17. Install the predetermined propellant fuel charge. Check the ignition initiating circuit for the correct resistance.
18. Install vent pin with new seal. Grease piston and cylinder. Place cylinder over piston.
19. Place reaction masses. Secure the masses to the cylinder assembly.
20. Place the gravel containment structure and secure into position.
21. Fill the annular space between the gravel containment structure and the Statnamic apparatus using gravel.
22. Check the assembled device to ensure there is no physical interference of the load or acceleration monitoring systems.
23. Clear the test work area of personnel.
24. Perform final check of instrumentation and recording equipment.
25. Perform the test.
26. Back up test data on hard drive or jump drive.

6.0 INSTRUMENTATION

The intent of the load test instrumentation is to measure the test load and its distribution between side friction and end bearing, load versus deflection, to provide information for design calculations and estimates, and to provide information for final design. The Contractor shall provide assistance when requested by Statnamic supplier during installation of any instrumentation supplied through this contract. The Contractor should be aware that lead times are required for ordering instrumentation. The Contractor shall take the lead times into account when planning the work. The instrumentation shall be installed prior to the construction or installation of the test shaft. A minimum of 45 days notice shall be given by the Contractor to the Statnamic supplier prior to test shaft construction to schedule the installation of the instrumentation.

The cost of all instrumentation, to be installed as directed by the Statnamic supplier, shall be included in the cost for Statnamic Load Testing. Instrumentation pertaining to the Statnamic testing, and listed below, shall be provided by the Statnamic supplier.

4. Electronic Resistance Based Strain Gages – A total of 20 resistance based strain gages shall be provided, 5 vertical levels with 4 gages per level. Lead wire should be unspliced.
5. Accelerometers – A total of 3 accelerometers shall be arranged across the top of the test

EXHIBIT 5 - SPECIAL PROVISIONS

shaft approximately 120 degrees apart during Statnamic testing.

6. Data Acquisition System – The resistance strain gages will require specialized equipment capable of digitizing at very fast rates. The Statnamic supplier shall supply the necessary equipment and record the test data.

7.0 METHOD OF PAYMENT

The quantity of the pay item “Drilled Shaft Axial Load Test” is measured by each (EA) Statnamic load test completed and accepted by the Department. A completed Statnamic load test shall be one test conducted on a shaft using the Statnamic method and meeting +/-15% of, or exceeding the target Statnamic test peak load as specified in the plans and Special Provisions.

The Statnamic load test shall be considered as any material, labor, equipment, instrumentation, etc. required above and including the requirements of test shaft installation. This item should include everything necessary to assemble, install, perform, collect data, and remove the Statnamic load test equipment; under the direction of the Statnamic supplier and others.

8.0 DISPOSITION OF TEST SHAFT

After all testing and data collection has been completed, the test shaft shall be cut off to a minimum depth of 5 feet below the ground surface. It shall be the Contractor’s responsibility to dispose of the cut off section of the test shaft.

9.0 BASIS OF PAYMENT

Statnamic load testing will be paid for at the contract bid price per each accepted test. The price and payment shall be considered full compensation for furnishing all materials, providing all tools, equipment, labor and incidentals, providing assistance to the production of the test shaft, performing the Statnamic load test, and disposing of the test shaft as described in Section 8.0 above.

10.0 PAYMENT

Payment shall be made under SCDOT Pay Item No. 7120166, “Drilled Shaft Axial Load Test”.

(88) PAVING UNDER GUARDRAIL

August 17, 2011

Section 403 is expanded as follows:

GENERAL:

Provide paving under guardrail as shown in the plans, in accordance with plan details and these special provisions. Pavement under guardrail shall only be placed where shown in the plans or as directed by the Engineer.

MATERIALS:

Pavement material under guardrail shall be the same as the hot mix asphaltic concrete surfacing being used on the adjacent roadway. Liquid asphalt binder shall be the same as that used for paving on the adjacent roadway.

EXHIBIT 5 - SPECIAL PROVISIONS

Low-density Flowable Fill with a maximum 28-day compressive strength of 120PSI shall be used to fill leave out areas.

CONSTRUCTION:

Place hot mix asphaltic concrete surfacing under guardrail in accordance with Section 401 of the Standard Specifications where indicated on the plans or as directed by the Engineer. Refer to details provided in this special provision for typical limits of paving and requirements for leave out areas around guardrail posts.

Pave area between the edge of pavement and the face of the guardrail when that distance is less than 20 feet.

Extend paving under guardrail to bridge end at locations where concrete approach slabs are used.

When at least one opening between parallel lines of guardrail is less than 20 feet wide, pave the entire area between the lines of guardrail.

When openings between parallel lines of guardrail are more than 20 feet wide, but obstructions such as bridge columns reduce the access between the guardrail and the obstruction to less than 20 feet and/or the distance between any two obstructions is less than 20 feet then the area with any single point of access less than 20 feet wide shall be paved.

When areas around obstructions are paved, no area should remain unpaved that will sustain plant life.

The top of pavement shall be constructed to be flush with surrounding earth shoulders and slopes.

Damage to pavement during subsequent construction, especially during driving of guardrail posts, should be minimized. Any damaged pavement must be restored to its original line and grade to the satisfaction of the Engineer.

Leave outs shown in the details shall be either formed or sawcut.

MEASUREMENT AND PAYMENT:

Hot mix asphalt surface course shall be measured and paid for in accordance with Section 401 of the Standard Specifications.

Liquid asphalt binder shall be measured and paid for in accordance with Section 401 of the Standard Specifications.

When additional excavation is required to obtain the depth of pavement specified, this additional excavation will be measured separately and paid for by the cubic yard as unclassified excavation in accordance with section 203 of the Standard Specifications.

When borrow is needed to construct the area to be paved to meet the typical section, this borrow excavation will be measured and paid for separately as borrow excavation in accordance with section 203 of the Standard Specifications.

The costs to provide the leave outs shall be considered incidental to the hot mix asphalt surface course and no separate measurement or payment shall be made for providing leave out areas.

Flowable fill for leave out areas will be measured and paid for in accordance with section 210 of the Standard Specifications.

Payment under this section will include the following:

EXHIBIT 5 - SPECIAL PROVISIONS

Item No.	Pay Item	Unit
2031000	UNCLASSIFIED EXCAVATION	CY
2033000	BORROW EXCAVATION	CY
2103000	FLOWABLE FILL	CY
40110XX	LIQUID ASPHALT BINDER PG__-22	TON
40303XX	HOT MIX ASPHALT CONCRETE SURFACE COURSE TYPE_	TON

EXHIBIT 5 - SPECIAL PROVISIONS

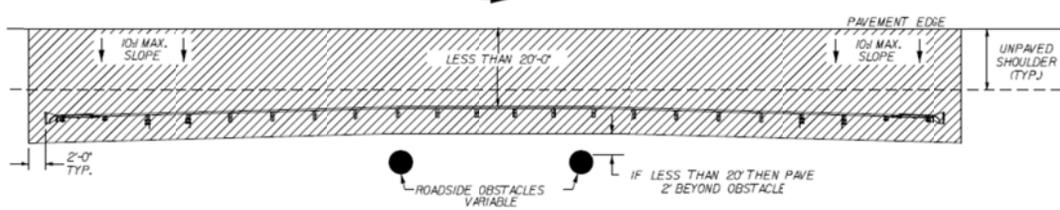
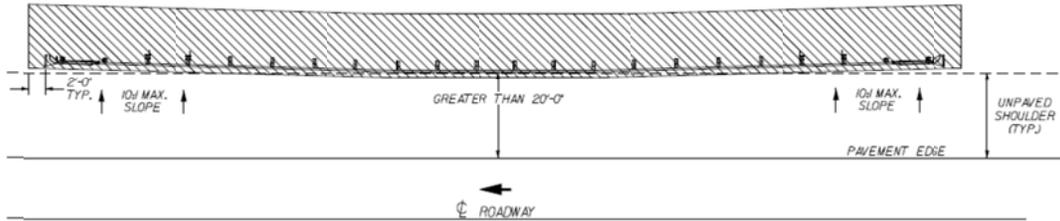

GUARDRAIL AROUND ROADSIDE OBSTACLES

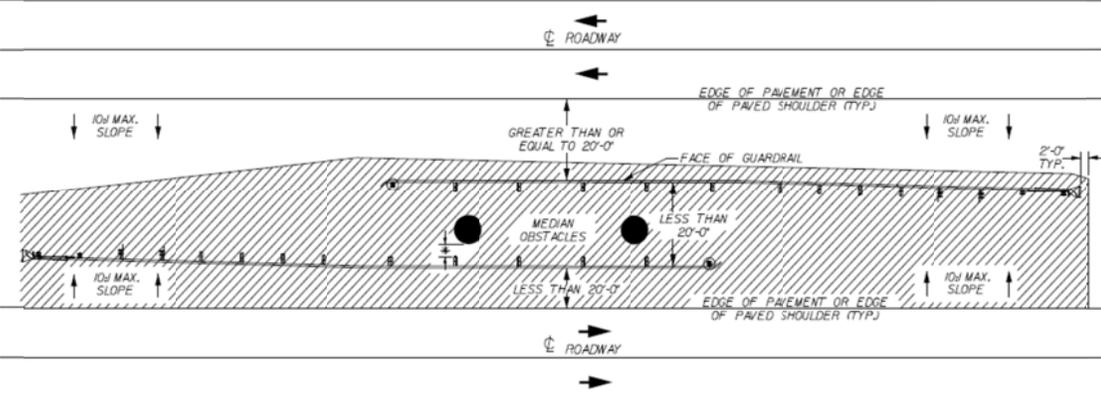

*WHEN BACK OF POSTS TO FACE OF OBSTACLE:
 IS GREATER THAN 36" W-BEAM MAY BE USED,
 IS 36" TO 24" USE THREE BEAM GUARDRAIL,
 IS LESS THAN 24" USE CRITICAL OFFSET GUARDRAIL
 SHOWN ON DRAWING 805-015-00.

GUARDRAIL AROUND MEDIAN OBSTACLES

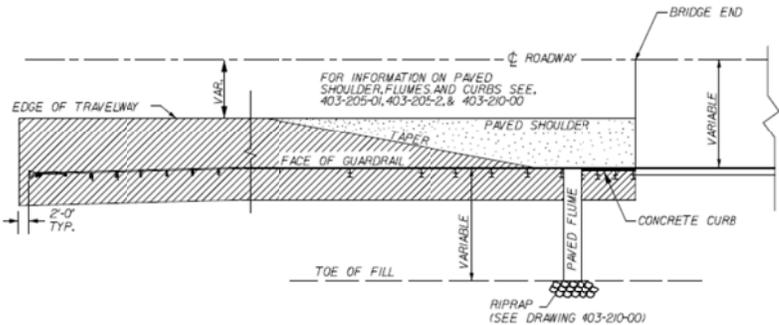

GUARDRAIL AT BRIDGE APPROACHES

HOT MIX ASPHALT
 SURFACE COURSE
 UNDER GUARDRAIL

EXHIBIT 5 - SPECIAL PROVISIONS

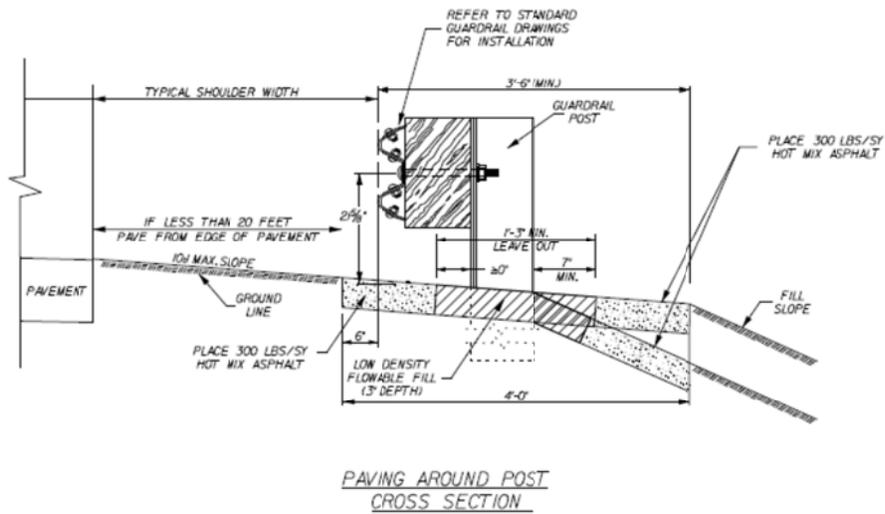
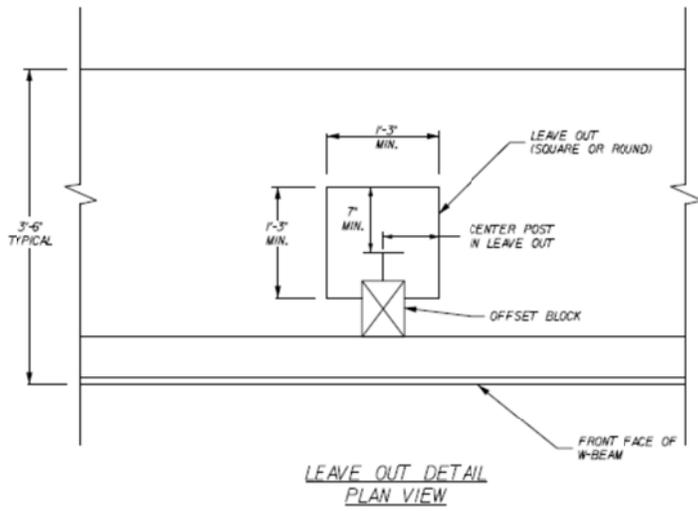

(89) DIVISION 600: ADHESIVELY BONDED ANCHORS AND DOWELS**1.0 Adhesively Bonded Anchors and Dowels****1.1 Scope**

Furnish all required labor, equipment, and materials and perform all operations necessary for installing anchors and dowels in concrete using an adhesive bonding system in accordance with the details shown on the Plans and with the requirements of this Specification. Provide a material system specifically intended for use in structural applications for bonding anchors and dowels to hardened concrete. Limit applications to anchors and dowels installed in horizontal, vertical, and downwardly inclined positions. Do not use adhesive anchors in overhead or upwardly inclined installations. See Figure 1.1.

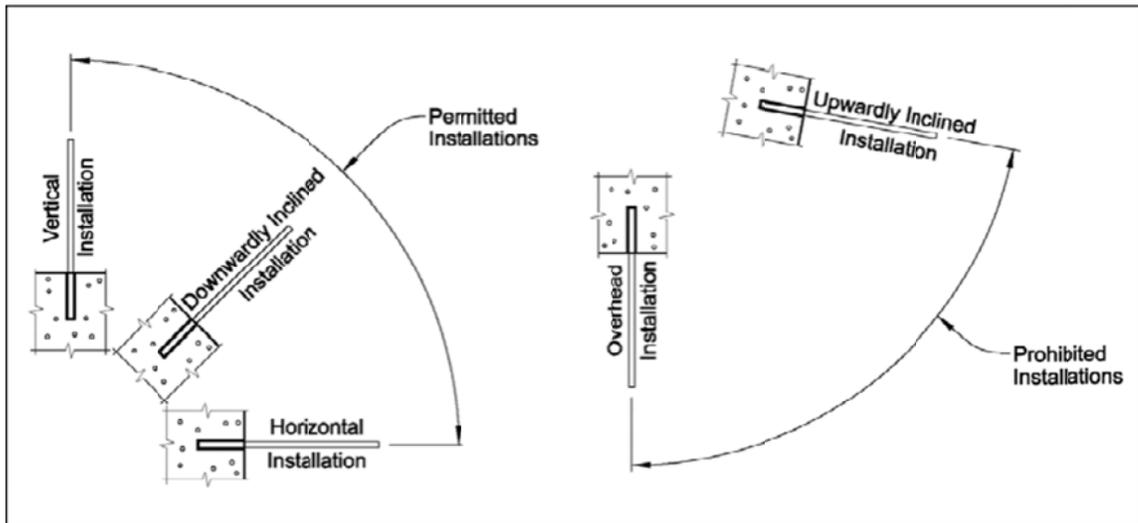

Figure 1.1

Submit a description of the proposed adhesive bonding system to the RCE for review, comments, and acceptance. Include in the description the anchor type, equipment, Manufacturer's recommended hole diameter, material specifications, and any other material, equipment or procedure not covered by the contract documents. List the properties of the adhesive, including density, minimum and maximum temperature application, setting time, shelf life, pot life, shear strength, bond strength, and compressive strength. If anchors or dowels containing a corrosion protective coating are required, provide an adhesive that does not contain any chemical elements that are detrimental to the coating and include a statement to this effect in the submittal concerning the contents as required by State or Federal Laws and Regulations.

Submit to the RCE Manufacturer's certification that the adhesive bonding system, when tested for tension pull-out according to ASTM E 488 utilizing identical anchorages, embedment depths, and concrete strengths as those specified on the Plans, does not fail by any mode listed in Section 12 of ASTM E 488 when loaded to the lesser of 85 percent of the specified bond strength (based on the nominal anchorage diameter and embedment depth) or 90 percent of the yield strength of the anchor. Also, submit to the RCE long term load (creep) test results performed in accordance with ASTM E 1512, ICC-ES AC 58, or ICC-ES

AC 308. When specified on the Plans, field testing will also be required for adhesive anchorages.

1.2 Materials

Provide adhesive bonding material systems for structural applications that meet the requirements of ASTM C 881, Type IV, Grade 3, Class B or C (depending on site conditions). Do not use "Fast Set epoxy." Package components of the adhesive in containers of such size that one whole container of each component is used in mixing one batch of adhesive. Use containers of such design that all of the contents may be readily removed, and are well sealed to prevent leakage. Do not use material from containers which are damaged or have been previously opened. Use only full packages of components. Furnish adhesive material that requires hand mixing in two separate containers designated as Component A and Component B or in a self contained cartridge or capsule that consists of two components which will be automatically mixed as they are dispensed, as in the case of a cartridge, or drilled into, as in the case of a capsule.

Provide packages clearly marked by the Manufacturer with the following information:

- Manufacturer's name and address
- Product Name
- Date of Manufacture
- Expiration Date
- LOT Identification Number
- Storage and Handling Requirements

With each package include the Manufacturer's instructions for anchor and dowel installation. Include the following information with the instructions:

- Diameters of drilled holes for applicable anchor and dowel sizes.
- Cleaning procedure for drilled holes, including a description of permitted and prohibited equipment and techniques.
- Allowable temperature ranges for storage, installation and curing.
- Identification of acceptable mixing/dispensing nozzles.
- Fabrication requirements for anchors and dowels.
- Description of tools permitted or required for installation.
- Method of identifying properly proportioned and mixed adhesive materials.
- Time and temperature schedule for initial set ('gel time') and full-strength cure.
- Requirements for special installation conditions such as horizontal or near horizontal orientation of the anchor or dowel.

1.3 Construction Requirements

1.3.1 Storage

Deliver the adhesive bonding material system to the job-site in original unopened containers with the Manufacturer's label identifying the product. Store materials delivered to the job-site in the original unopened containers within an appropriate facility capable of maintaining storage conditions consistent with the Manufacturer's recommendations.

1.3.2 Installation

Install the adhesive anchors and dowels perpendicular to the plane surface of the structural member, in accordance with Manufacturer's recommendations, and when the concrete is above

40 degrees Fahrenheit and has reached its 28 day strength. Install the anchorages before the adhesive's initial set ('gel time').

1.3.2.1 Drilling of Holes into Concrete

Ensure that concrete members receiving adhesive-bonded anchors or dowels are structurally sound and free of cracks in the vicinity of the anchor or dowel to be installed. When directed by the RCE, use a jig or fixture to ensure the holes are positioned and aligned correctly during the drilling process.

Use a metal detector specifically designed for locating steel in concrete to avoid conflicts with

existing steel reinforcement whenever placement tolerances and edge clearances permit. Unless other equipment is recommended by the Manufacturer, drill holes to the diameter required by the Manufacturer using a rotary hammer drill and bit. Perform core drilling to clear existing steel reinforcement only when approved by the RCE. Dry the drilled holes completely prior to cleaning and installing the anchors or dowels. Clean and prepare drilled holes in accordance with the Manufacturer's recommendations, but as a minimum, use oil-free compressed air to remove loose particles from drilling, brush inside surface to free loose particles trapped in pores, then use compressed air again to remove the remaining loose particles. Use a non-metallic bristle brush and avoid over-brushing to prevent polishing the inside surface of the drilled hole. Check each hole with a depth gauge to ensure proper embedment depth. Repair spalled or otherwise damaged concrete using methods approved by the RCE.

1.3.2.2 Inspection of Holes

Inspect each hole immediately prior to placing the adhesive and the anchors/dowels. Ensure all holes are dry and free of dust, dirt, oil, and grease.

1.3.2.3 Mixing of Adhesive

Mix the adhesive in strict conformance with the Manufacturer's instructions.

1.3.2.4 Embedment of Anchors and Dowels

Remove all debris, oils, and any other deleterious material from the anchors and dowels to avoid contamination of the adhesive bonding material. Insert the anchor or dowel the specified depth into the hole and slightly agitate it to ensure wetting and complete encapsulation. After insertion of the anchor or dowel, strike off any excessive adhesive flush with the concrete face. Should the adhesive fail to fill the hole, add additional adhesive to the hole to allow a flush strike-off. Do not disturb the anchors and dowels while adhesive is hardening. For horizontal and inclined installations, provide temporary supports to maintain the alignment of the anchors or dowels until the adhesive bonding material has cured.

1.3.3 Field Testing

When specified on the Plans, field test the installed anchors and dowels. Perform field testing of the installed anchors and dowels in accordance with the applicable sections of ASTM E 488. Inform the RCE and the Manufacturer when the tests will be performed at least 2 days prior to testing. For testing, use a calibrated hydraulic centerhole jack system that will not damage the anchor or dowel. Place the jack on a plate washer that has a hole at least 1/4" larger than the hole drilled into the concrete. Position the plate washer on center to allow an unobstructed pull. Position the anchors/dowels and the jack on the same axis.

EXHIBIT 5 - SPECIAL PROVISIONS

Have an approved testing agency calibrate the jack within 6 months prior to testing. Supply the RCE with a certificate of calibration.

Divide the anchors and dowels into LOTs for field testing and acceptance. A LOT consists of anchors or dowels of the same type, diameter, strength, embedment length, and adhesive bonding system. Prior to performing field tests, submit proposed testing locations to the RCE for review, comments, and acceptance. In the presence of the RCE, field test the anchors or dowels for each LOT in accordance with the following:

Test a minimum of 1 anchorage but not less than 10% of all anchors in the LOT to the test load shown on the Plans.

If less than 60 anchorages are to be installed: Install and test the minimum required number of anchorages prior to installing the remaining anchorages. After installing the remaining anchorages, test a minimum of 2 of these anchorages at random locations selected by the RCE.

If more than 60 anchorages are to be installed: Test the first 6 anchorages prior to installing the remaining anchorages. Then test, at random locations selected by the RCE, 10% of the number in excess of 60 anchorages.

For every failed field test, perform two additional field tests on adjacent untested anchors or dowels within the LOT. Continue additional field tests until no more test failures occur, or until all anchors and dowels within the LOT are tested.

Begin testing after the Manufacturer's recommended cure time has been reached. For testing, apply and hold the test load for three minutes. If the jack experiences any drop in gage reading, restart the test. For the anchorage to be deemed satisfactory, hold the test load for three minutes with no movement or drop in gage reading.

Remove all anchors and dowels that fail the field test, without damage to the surrounding concrete. Re-drill holes to remove adhesive bonding material residue and clean the hole in accordance with Subsection 1.3.2.1. For reinstalling replacement anchors or dowels, follow the same procedures as new installations. Do not reuse failed anchors or dowels unless approved by the RCE.

Determine failure of the field test in accordance with ASTM E 488. Submit certified test reports to the RCE. Final acceptance of the adhesively anchored system is based on the conformance of the pull test to the requirements of this Specification. Failure to meet the criteria of this Specification is grounds for rejection.

1.4 Measurement

No separate measurement for payment will be made for furnishing, installing, and testing of adhesively bonded anchors and dowels.

1.5 Payment

Include all costs of adhesively bonded anchors and dowels in the contract unit price bid for the items to be anchored.

(90) ELASTOMERIC CONCRETE FOR EXPANSION JOINT HEADERS

EXHIBIT 5 - SPECIAL PROVISIONS

1.0 Elastomeric Concrete for Expansion Joint Headers

1.1 Scope

Furnish all required labor, equipment, and materials and perform all operations necessary for installing the elastomeric concrete in accordance with the details shown on the Plans and with the requirements of this Specification.

1.2 Materials

Provide elastomeric concrete that is a mixture of a two-part polymer consisting of polyurethane and/or epoxy and kiln-dried aggregate, with the materials being supplied as a unit by the Manufacturer.

Provide materials that comply with the following minimum requirements at either 14 days or at the end of the specified curing time.

ELASTOMERIC CONCRETE PROPERTIES	TEST METHOD	MINIMUM REQUIREMENT
Compressive Strength, psi	ASTM D 695	2000
5% Deflection Resilience	ASTM D 695	95%
Splitting Tensile Strength, psi	ASTM D 3967	625
Bond Strength to Concrete, psi	ASTM C 882	450
Durometer Hardness	ASTM D 2240	50

BINDER PROPERTIES (without aggregate)	TEST METHOD	MINIMUM REQUIREMENT
Tensile Strength, psi	ASTM D 638	1000
Ultimate Elongation	ASTM D 638	150%
Tear Resistance, lb/in	ASTM D 624	200

In addition to the requirements above, provide elastomeric concrete that is resistant to water absorption, is resistant to chemical, UV, and ozone exposure, and is capable of withstanding temperature extremes.

Furnish a Manufacturer's certification verifying that the materials satisfy the above requirements. Provide samples of elastomeric concrete to the RCE, if requested, to independently verify conformance with the above requirements.

Provide material in packages clearly marked by the Manufacturer with the following information:

- Manufacturer's name and address
- Product Name
- Date of Manufacture
- Expiration Date
- Batch Number
- Mixing Instructions

EXHIBIT 5 - SPECIAL PROVISIONS

- Storage and Handling Requirements
- Material Safety Data Sheets

1.3 Construction Requirements

1.3.1 Storage

Prior to beginning construction, deliver sufficient materials to the job-site to construct entirely the elastomeric concrete headers as detailed on the Plans. Store materials delivered to the job-site in the original unopened containers within an appropriate facility capable of maintaining storage conditions consistent with the requirements of the Manufacturer.

1.3.2 Installation

Provide a Manufacturer's representative on the job-site during the first installation of the elastomeric concrete to ensure that all aspects of the installation is in compliance with the Manufacturer's requirements. Do not proceed with installation until the weather conditions meet the requirements of the Manufacturer.

Place a bond breaker on the area where the elastomeric concrete headers are to be constructed before placing the asphaltic concrete overlay over the joints. After the overlay is placed, sawcut the overlay to the width shown on the plans, and remove the bond breaker and overlay material in the joint area.

Clean and dry the bonding surfaces and prepare joint surfaces according to the Manufacturer's instructions. Prepare and apply a primer to areas specified by the Manufacturer and in accordance with Manufacturer's instructions. Mix and place the elastomeric concrete, in accordance with the Manufacturer's instructions, into the prepared area on each side of the expansion joint.

Form and cast the elastomeric concrete headers to smoothly match the surface of the finished roadway. Finish the surface to a moderately rough texture such as that produced by a wood float. Protect the elastomeric concrete header material from damage, and allow the headers to cure properly prior to opening the work area to traffic. Do not open to traffic without the written approval of the Manufacturer. Provide a copy of this approval to the RCE.

1.3.3 Warranty

Provide a Manufacturer's warranty that the elastomeric concrete will not delaminate, debond, rut, or otherwise fail to perform for five years after the time the bridge is opened. Include in the warranty that the Manufacturer is required to repair or replace, at the discretion of SCDOT, all elastomeric joint headers that fail during the warranty period at no additional cost to the SCDOT and within three months of SCDOT's written request to do so. Also include the SCDOT file number and the estimated date the bridge will be opened. Do not include in the warranty acts of God or failures adjacent to the installation. If the joint needs to be repaired or replaced by the Manufacturer before the warranty expires, SCDOT will provide, with three weeks' notice, traffic control for a time interval specified by the Manufacturer. Include in the warranty that if the replacement or repair affects the expansion joint material, the Manufacturer is required to install new expansion joint material. Replaced or prepared installations must use materials meeting the requirements of this Specification and the original Plans.

1.4 Measurement

EXHIBIT 5 - SPECIAL PROVISIONS

No separate measurement for payment will be made for furnishing and installing of elastomeric concrete, providing the Manufacturer's representative, or for furnishing the warranty.

1.5 Payment

Include all costs of elastomeric concrete in the contract unit price bid for Expansion Joint System with Concrete Header.

(91) DIVISION 702: CONCRETE STRUCTURES – PREFORMED JOINT FILLER

Delete Subsection 702.2.2.1 of the Standard Specifications in its entirety and replace it with the following:

702.2.2.1 Preformed Joint Filler

Use preformed joint material that meets AASHTO M 153 or AASHTO M 213 with the following exceptions:

1. Use only materials manufactured from rubber.
2. Use materials that require a load of not less than 340 kPa or greater than 5200 kPa to compress to 50% of its thickness when tested in accordance with AASHTO T 42.
3. Use materials that have a recovery of at least 70% when tested in accordance with AASHTO T 42.

Use preformed joint material that is listed on QPL 81.

Provide a manufacturer's certification that states that the material conforms to SCDOT specifications.

(92) TEMPORARY SHORING WALL

October 3, 2002

The Standard Specifications for Temporary Sheet Piling are hereby amended as follows:

Delete sub-sections A, B, & C of Section 204.09 and replace them with the following:

A. DESCRIPTION. This work shall consist of the designing, furnishing, installing, maintaining, and removing (if required by the Engineer) the temporary shoring walls at the locations shown on the plans. A temporary shoring wall may be, but is not limited to one of the following types unless specified otherwise in plans:

- a. Steel sheet pile wall – braced or tieback
- b. Steel soldier piles with lagging – braced or tieback
- c. Temporary Mechanically Stabilized Earth (MSE) wall with welded wire form facing and geosynthetic wrap for fill situations.

This item is designated as “temporary” due to its limited service life that is typically until construction of a permanent structure (i.e. embankment, bridge abutment, etc.) is completed. Even though the shoring is “temporary” it may remain in place at the end of construction due to the impracticality of removing the shoring components (i.e. tie backs, soil reinforcement, etc.) or the potential of damage to the permanent structure that may exist during extraction of the shoring components.

B. DESIGN. Temporary shoring walls shall be designed to resist all dead and live loadings (earth pressures, hydrostatic pressures, traffic loads, point loads, line loads, and surcharge loads) that the retaining system may experience during the service life of the structure. The temporary

EXHIBIT 5 - SPECIAL PROVISIONS

shoring walls shall be designed in accordance with the latest edition of the AASHTO Standard Specifications for Highway Bridges, with interim specifications, and the applicable requirements of section 702.10 entitled "Falsework Design and Inspection". Temporary shoring walls shall be designed, signed, and sealed by a Registered Professional Engineer, registered to practice in the State of South Carolina.

The Contractor shall be responsible for the external stability of all temporary shoring walls. Any geotechnical investigation necessary to verify the external stability shall be included in the unit price for Temporary Shoring Wall. Differential and absolute settlements of temporary walls shall be limited to ensure minimal detrimental effects.

Temporary shoring walls shall be designed in accordance with the design criteria provided below:

1. Design Methodology: Design methodology shall be in accordance with accepted AASHTO design methodology. Temporary MSE walls shall be designed using the Simplified Coherent Gravity approach of determining maximum reinforcement loads, T_{max} . Temporary shoring walls are not required to resist seismic forces from earthquake events.
- 2.
2. Design Life: All temporary shoring walls shall be designed for a minimum of 3 years design life. Temporary shoring walls that will be in use for more than 5 years shall be designed as permanent retaining wall structures.
3. Soil Design Parameters: Temporary shoring walls shall be designed using appropriate soil properties relative to the anticipated service life. Temporary shoring that will be in-place for a period where excess pore pressures have not dissipated (typically less than 4 to 6 months) shall be designed using total (undrained) soil shear strength parameters. Effective (drained) soil shear strength (drained) parameters should be used when temporary shoring walls are in service sufficiently long (typically more than 4 to 6 months) for excess pore pressures to dissipate.
4. For Temporary MSE Walls use following External Stability Minimum Safety Factors:
 - Global Stability Factor of Safety, $FS_{Global} = 1.3$
 - Sliding Stability Factor of Safety @ Base, $FS_{Base} = 1.5$
 - Sliding Stability Factor of Safety @ Reinforcement, $SF_{Reinforcement} = 1.5$
 - Overturning Factor of Safety, $FS_{Overturning} = 2.0$
 - Eccentricity, $e < L/6$

(Where L = Reinforcement Length for Temporary MSE Walls)

 - Bearing Capacity Factor of Safety, $FS_{Bearing} = 2.5$
5. For Temporary MSE Walls use following Internal Stability Minimum Safety Factors:
 - Pullout Factor of Safety, $FS_{Pullout} = 1.5$
 - Reinforcement Rupture Factor of Safety, $SF_{Rupture} = 1.2$
6. For Temporary MSE Wall Soil Reinforcement:
 - The soil reinforcement length should be selected based on the longest soil reinforcement length required to meet the following design requirements:

(93) DIVISION 200: VIBRO COMPACTION

This section presents administrative and procedural requirements for ground modification by Vibro-Compaction (VC). Vibro-compaction shall be implemented in and below the existing embankment fill

EXHIBIT 5 - SPECIAL PROVISIONS

material of both the beginning of bridge approach embankment and the end of bridge approach embankment. VC shall be provided as documented in the plans. The purpose of the vibro-compaction program is to densify the granular soils at the specified locations and depths to mitigate liquefaction potential.

The Contractor shall perform layouts and measurements for VC work. VC points may be surveyed in or located by measuring offsets from surveyed points (e.g., project stations) using a tape measure.

The Contractor shall notify the Engineer a minimum of 48 hours prior to commencement of the VC operations at each approach embankment location.

Any change in the predetermined VC program necessitated by a change in the field conditions shall be immediately reported and submitted to the Geotechnical Engineer. Upon completion of the work, the Contractor shall submit a drawing of as-built locations of vibro-compacted columns.

REFERENCES

The Geotechnical Engineer will coordinate all testing to determine compliance with the project design.

- A. Applicable Standards: The most recent version of the following testing methods or standards shall be employed:
 - 1. ASTM D1586 "Standard Test Method for Standard Penetration Test (SPT) and Split-Barrel Sampling of Soils"
 - 2. ASTM D5778 "Standard Test Method for Electronic Friction Cone and Piezocone Penetration Testing of Soils" (CPT)
 - 3. ASTM D6635 "Standard Test Method for Performing the Flat Plate Dilatometer" (DMT)
- B. Reference Documents: Reference documents to be used by the Contractor shall include:
 - 1. This specification.
 - 2. Attached plans.
 - 3. Project geotechnical report prepared by the Geotechnical Engineer.

Prior to commencing work, the contractor shall examine the site, drawings, records of existing utilities and other existing subsurface structures, and soil test boring logs made available in the original bid documents and those performed by the Geotechnical Engineer to help determine VC installation conditions.

SUBMITTALS

This section details all submittals required prior to field work, at completion of the test section, during production work, and after the work is completed.

- A. Pre-Field Work Submittals: The following shall be submitted to the SCDOT by the Geotechnical Engineer prior to the start of the work. VC operations may not commence until approval by the SCDOT is granted.
 - 1. A Work Plan prepared by the Contractor for the production work outlining the anticipated spacing, location and depth to achieve the project design criteria.

EXHIBIT 5 - SPECIAL PROVISIONS

2. Drawing(s) for review, indicating the spacing, location, and depth of the VC probes to achieve the project design criteria.
- B. Post Test Section and Pre Production Work:
1. Results of the test section evaluation.
 2. A revised work plan and VC layout should the test section results require a modification to the original work and production plans.
- C. During Production Submittals: The following shall be submitted to the SCDOT by the Geotechnical Engineer during the work:
1. Any change in the predetermined VC program necessitated by a change in the field conditions.
- D. Closeout Submittal: The following shall be submitted to the SCDOT by the Geotechnical Engineer within 14 days of the completion of the VC work.
1. As built drawings: Drawings documenting any significant changes to the shop drawing. If no changes are noted, then no as-built drawings are necessary following completion of the VC program.

EQUIPMENT AND MATERIALS

The Contractor shall supply equipment in good operating condition capable of performing the work specified herein. The Contractor shall use equipment capable of efficiently accomplishing the required soil densification. The probe shall have durable markings on one foot intervals allowing a visual determination of the depth of penetration when in use. The probe shall be of sufficient length to extend a minimum depth of thirty (30) feet below existing grade.

The VC procedure is not intended to be a 'wet' operation. Water shall be used sparingly to mitigate clogging of the VC equipment.

Settlement resulting from the VC operations is anticipated. Any required fill placement in the resulting deformations required to meet the design grade(s) shall meet the requirements outlined in the *Special Provision 40 – Section 203: Borrow Excavation* provided in the bid documents.

Groundwater is anticipated to emerge to the ground surface during VC operations. The Contractor shall implement Best Management Practices (BMP's) to efficiently control surface groundwater runoff in accordance with the contract documents.

CONSTRUCTION

Production VC criteria shall be as follows:

1. Depth of treatment: The probe tip shall penetrate to the minimum elevation specified in the above referenced documents and submittals.
2. Locations/Spacing: The center to center probe spacing shall adhere to the requirements in the above referenced documents and submittals. Probes shall be performed within 12 inches of the planned location
3. Limits of work: The limits of the VC work are shown on the drawings described in the

EXHIBIT 5 - SPECIAL PROVISIONS

above referenced documents and submittals.

QUALITY CONTROL

The details of the quality control program are as follows:

- A. Technical Oversight: All VC operations shall be performed under the inspection of the Geotechnical Engineer's representative.
- B. Monitoring and Logging: Monitoring and logging of all VC operations for the test area and production work shall be done by the Contractor.
- C. Test Section: The Geotechnical Engineer's representative shall monitor the performance of the test section and perform the testing indicated below:
 1. A test section shall be performed before production work, as follows:
 - a. The test section location shall be agreed upon by the Geotechnical Engineer and the Contractor within the treatment area. The test section will consist of a minimum of twelve (12) VC points in three (3) rows of four (4) points each. For preliminary design considerations, the vibro-densification program will utilize a five (5) foot triangular grid for the indicated treatment area(s).
 - b. The method of installation, materials, equipment, and procedures shall be the same as those to be used for production work.
 - c. Based on the results from the test section, modifications to the Work Plan may be implemented, as needed, to meet the project design. Any changes to the Work Plan will be submitted to the SCDOT following completion of the test program.
 2. The Geotechnical Engineer shall coordinate the following tests of the test section after a minimum wait period of four (4) days from completion of the VC activities of the test program: One (1) CPT (*or* SPT) test performed at the center of a VC probe location, and one (1) CPT (*or* SPT) test performed at the midpoint of adjacent VC probe locations.
 3. The primary method for determining the post-treatment soil strength parameters for production VC work will be from the phi angle correlations in Chapter 7 of the SCDOT Geotechnical Design Manual. These equations are based on either the blow counts as determined from the SPT test, the cone tip resistance as determined from the CPT test, or the horizontal stress index as determined from the DMT test.
 4. The production VC criteria will be based on a minimum applied relative energy for a given time rate. Following completion of the test program, the Geotechnical Engineer will establish criteria for the production VC work.
- D. Daily Records: Monitoring and logging of VC operations for the test area and production work shall be performed by the Contractor. At a minimum, the following information shall be collected for each VC probe location:
 - a. Equipment details and specifications
 - b. Embankment location
 - c. Probe ID (ie. A-27)
 - d. Start and finish time
 - e. Maximum recorded energy reading
 - f. Depth of treatment

EXHIBIT 5 - SPECIAL PROVISIONS

g. Comments or unusual observations

A sample monitoring log for the VC work is provided with this specification.

- E. Monitoring of Existing Structures: There are no structures within 500 feet of the planned VC work, and, therefore, a vibration monitoring program is not required for the VC work.
- F. The Contractor shall ensure that procedures and documentation conform to these specifications.

METHOD OF MEASUREMENT

The acceptance of the VC work shall be solely based on the results from the pre-treatment test program outlined in this specification. The Geotechnical Engineer shall provide to the SCDOT a signed and sealed statement that the soil improvement conforms to requirements of the project design.

RESTRICTIONS

The Contractor shall be responsible for obtaining the necessary State and municipal permits for the intended construction. The Contractor shall be responsible for the precise delineation of all above and below ground utilities and obstructions and shall accurately mark their layout at the site. The following shall also be listed within this section when applicable:

1. Environmental restrictions
2. Work boundaries
3. Hours and days available for construction

(94) SECTION 203: BORROW EXCAVATION

March 6, 2013

Section 203.2.1.8 of the Standard Specifications is amended as follows:

Ensure that all borrow material placed on embankments meet or exceed the requirements for total and effective internal friction angle, cohesion, and total moist unit weight as specified by the geotechnical design engineer of record. These requirements shall be determined by the following tests:

- Internal friction angle determined from either direct shear (AASHTO T236) or triaxial (AASHTO T297) testing on remolded specimens performed by the Contractor.
- Cohesion determined by triaxial (AASHTO T297) testing on remolded specimens performed by the Contractor.
- Total moist unit weight determined by standard proctor test (AASHTO T99) on remolded specimens performed by the Contractor.

Remold all samples to 95 percent of the maximum dry density as determined by the Standard Proctor test (AASHTO T99) and test at normal/consolidation stresses specified by the geotechnical design engineer of record. Conduct shear strength and soil classification testing (AASHTO M145) at the initial selection of the borrow pit, any subsequent changes in borrow pits, and for every 50,000 cubic yards of materials placed. This testing is in addition to the normal embankment and borrow sampling and testing requirements for classification and compaction in accordance with Section 205 of the SCDOT Standard Specifications for Highway Construction that are used for daily acceptance.

Perform additional shear strength testing and/or soil classification testing at no additional cost to the Department when the Department deems that the materials being placed appear to be different from those originally tested. Submit all test results to the RCE for approval prior to use in embankment construction. The RCE will also submit copies of the test reports to the Quality Assurance Engineer at

EXHIBIT 5 - SPECIAL PROVISIONS

the Office of Materials and Research. Use only qualified laboratories that are appropriately accredited by AASHTO to perform the test procedures required by this specification.

Do not use material derived from Unclassified Excavation to construct embankments unless that material meets the requirements for Borrow Material as stated above.

(95) DIVISION 700: MONITORING OF CONSTRUCTION-RELATED EARTHBORNE VIBRATIONS

Division 100 is expanded as follows:

1.0 DESCRIPTION:

The project construction will generate vibrations that will travel through the earth, which will subsequently be received or "sensed" by nearby structures and inhabitants. Specific procedures that will generate earthborne vibrations during bridge and roadway construction include (but are not limited to) the installation of piles, earthquake drains, shoring walls, general foundation construction, and vibratory compaction of unclassified or borrow excavation. To mitigate the risk of vibration-related damage to nearby structures, this specification outlines the Contractor's responsibility for performing a program of pre-construction condition assessment and vibration monitoring during construction.

This specification is based, in part, on AASHTO R 8-96 (2004) *Standard Recommended Practice for Evaluation of Transportation-Related Earthborne Vibrations*. As discussed in AASHTO R 8-96 (2004), humans respond to a much broader range of vibration frequencies and intensities than structures. Intrusive vibration levels can annoy humans at much lower intensities than levels considered critical for structures. Thus, occupants of adjacent properties may perceive that the construction-induced vibrations may present risk to their structures. The recommended safe vibration limits are intended to mitigate the risk of structure damage, and more specifically, reduce the development of "threshold cracks" or cosmetic cracking. Such cracks may appear at lower vibration levels than the level at which architectural or minor structural damage would be expected to occur.

2.0 PRE-CONSTRUCTION CONDITION ASSESSMENT:

The Contractor shall retain a geotechnical engineering firm to perform a pre-construction condition assessment to document the conditions of nearby buildings and other sensitive nearby structures prior to the beginning of construction. The assessment shall be performed on all properties adjacent to the project site and any other properties as directed by the Engineer. The assessment shall include any structures within 300 feet of any vibration inducing construction activity. The assessment should include video and photographic documentation of all exteriors and interiors, and installation of crack monitors on cracks that might propagate due to construction vibrations. All documentation of existing building conditions and information concerning the type and location of crack monitors shall be presented to the Engineer in a report prior to construction.

3.0 CRACK MONITORING DURING CONSTRUCTION:

During all construction, the Contractor shall perform periodic readings of the crack monitors that were installed during the pre-construction condition assessment. All readings shall be provided to the Engineer within 48 hours of taking the reading. Provided that the crack readings confirm that vibrations are not contributing to increasing the crack width, the crack monitors may be read once per week. More frequent readings may be directed by the Engineer during activities that are expected to have greater earthborne vibrations (e.g., pile driving). If the crack readings suggest that vibrations from the project site are contributing to crack width, then the Contractor shall immediately notify the Engineer and review those activities that are generating the earthborne vibrations. The Contractor and his or her geotechnical firm shall then submit a detailed plan for repair, perform the repair at no cost to the Department and develop and submit for review a revised construction plan to address the vibration problems and minimize further damage and complaints.

4.0 VIBRATION MONITORING DURING CONSTRUCTION:

- A. Procedure - The Contractor shall monitor vibrations at no less than four locations along the perimeter of the project during all foundation and embankment construction activities. The locations shall be selected by the Contractor based on the location of the construction activities and their relative position to nearby offsite structures. Prior to construction, a plan of the monitoring locations shall be submitted to the Engineer for acceptance. The locations of the vibration monitors shall be adjusted during construction with acceptance by the Engineer. The vibration monitors shall be established at the site so that background vibrations may be determined prior to beginning foundation or embankment construction. The sensitivity range of the seismograph shall be selected so that the recording is initiated below the maximum allowable particle velocity shown in Figure 1 and extends above the highest expected intensity. Specific activities of the vibration source shall be indexed in time to allow correlation with the arrivals on the vibration
- B. Project Vibration Criteria - The maximum allowable particle velocity is shown in Figure 1. If the data from the monitors indicate that vibrations are exceeding the established criteria, then the Contractor shall immediately notify the Engineer and suspend those activities which are generating the earthborne vibrations, until the Contractor and his or her geotechnical firm have developed a revised construction plan to resolve the problem. The problem shall be resolved at no additional cost to the Department.
- C. Instrumentation – The vibration monitors shall consist of digital seismographs that display the particle velocities and associated frequencies plotted against the criteria for this project (i.e., Figure 1). Each seismograph shall contain geophones with response capability in three mutually perpendicular axes or components: one vertical and two horizontal (radial and transverse). The frequency response of the geophones shall be linear from at least 4 Hz to more than 200 Hz. The sensitivity shall range from less than 0.02 in/sec to more than 5.0 in/sec. The BlastMate III by InstanTel is one type of seismograph that is suitable for this project.
- D. Calibration and Instrument Use - The Contractor shall field calibrate the vibration monitors before the start of each recording period. The transducer shall be positioned with the longitudinal axis toward the vibration source. Transducers must be adequately coupled with the ground. Operation of all vibration monitors shall be in accordance with the instrument manufacturer's instructions and recommendations. Vibration records shall be collected in waveform plot or strip chart plot. The peak vector sum of the particle velocity in longitudinal, transverse, and vertical planes shall be shown along with the respective dominant or principle frequencies. The highest recorded particle velocity (i.e., the vector sum of the three orthogonal directions), when indexed to a particle vibration event, shall be reported as the peak particle velocity. The recorded peak particle velocity shall be compared to criteria appropriate for the subject of concern.
- E. Complaints - In the event of a complaint, the Contractor shall immediately contact the Engineer and review those construction activities that are inducing vibrations into the earth. The Contractor shall prepare a report documenting all relevant data such as the time and date presented in the complaint, a description of the construction activities during the subject time/date, data from the monitoring instruments for the subject time/date, complaint information and a description (including photographs, if possible) of the alleged damage. The Contractor and his or her geotechnical firm shall then submit a detailed plan for repair, perform the repair at no cost to the Department and develop and submit for review a revised construction plan to address the vibration problems and minimize further damage and complaints.

METHOD OF MEASUREMENT:

In addition to the pre-construction condition assessment report, the Contractor shall also provide monthly reports containing the results of the crack monitors and vibration monitors during those activities that generate earthborne vibrations, including (but not limited to) ground improvement and foundation construction. The reports shall document that the Contractor is providing the work described by this specification.

EXHIBIT 5 - SPECIAL PROVISIONS

5.0 BASIS OF PAYMENT:

Payment shall be made in proportion with the percent of the project that is complete. Final payment of the remaining lump sum balance shall be made when vibration monitoring is complete as approved by the Engineer. Payments shall be made under:

Item No.	Pay Item	Pay Unit
1075001	MONITORING OF CONSTRUCTION-RELATED EARTHBORNE VIBRATIONS	Lump Sum

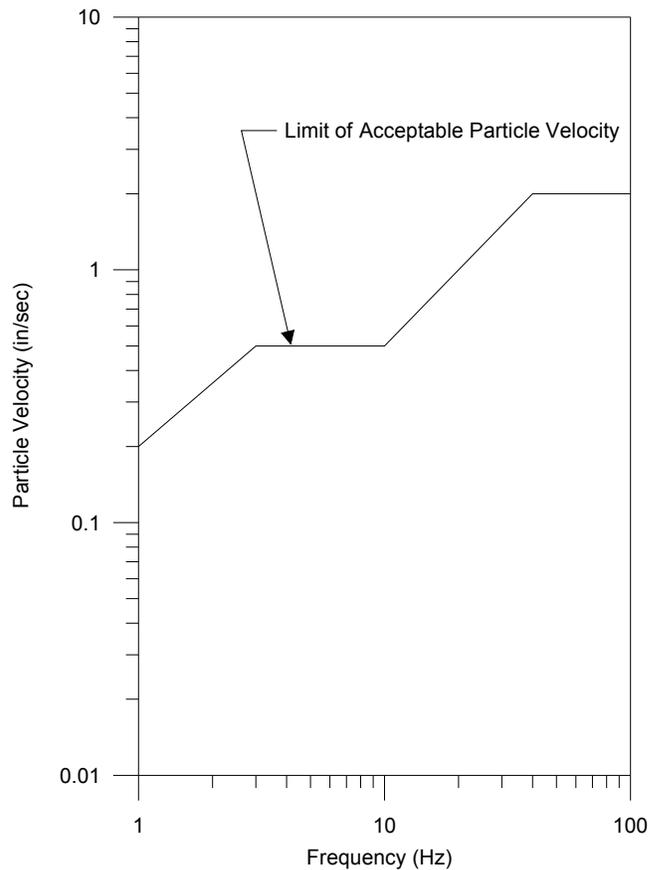

Figure 1. Vibration Criteria (adapted from AASHTO R8-96)

(96) SECTION 729: NAVIGATION LIGHTS FOR BRIDGE

729-1 Description.

Furnish and install navigation lighting systems, including all wiring, conduit, wiring devices, transformers, enclosures, grounding system, controls, protective devices, lights, etc., in compliance with

EXHIBIT 5 - SPECIAL PROVISIONS

Code of Federal Regulations (CFR), Title 33, Part 118, which is further clarified in U.S. Coast Guard (USCG) Publication "A Guide to Bridge Lighting". Navigation lights must operate from sunset to sunrise and during periods of low visibility.

729-2 Coordination of Electrical Work.

Use experienced personnel in the type of work required by the Contract Documents to provide a complete and satisfactory fitting and fully operational installation. Perform all electrical work either by, or under the immediate supervision of an electrical journeyman. Schedule and arrange electrical work in a neat, well-organized manner without interference with the work scheduling of other trades.

729-3 Materials and Equipment.

Meet the equipment and material requirements as shown in the Contract Documents. Furnish and install only materials and equipment of new stock meeting ANSI, NEC, NEMA, and UL requirements, and approved by the Engineer, except where the Contract Documents allow or specify the use of other than new equipment.

Furnish and install marine type products manufactured of corrosion resistant materials.

Furnish and install only fasteners manufactured from ASTM 316 stainless steel with yield strength 35,000 psi or higher.

Furnish and install ASTM 300 series stainless steel conduit straps or hangers held at not less than two points.

Furnish and install framework for supporting boxes, switches, and other externally mounted electrical devices fabricated from ASTM A709 Grade 36 hot-dip galvanized structural steel.

729-4 Navigation Lights and Aids.

729-4.1 Navigation Lights: Equip all navigation lights with a LED array with a minimum of 50,000 hour life and bright enough to meet the visibility requirements of CFR Title 33, Part 118. Mount LED arrays on an internal shock and vibration isolator. Provide, in the circuit, a lightning surge suppressor capable of absorbing multiple strikes without replacement. Provide special power supply to provide current limited DC voltage to the LED array.

Furnish and install fixtures with unpainted housings of heavy duty cast aluminum or bronze construction with a 1-1/2 to 2 inch threaded conduit opening on the bottom. Use only marine type mounting boxes with minimum 3/4 inch conduit opening. Furnish and install fixtures with lenses that are standard marine molded, single-piece fresnel type, rigid, heat resistant glass or U.V. resistant polycarbonate and inside diameter of 7 to 8 inch. Furnish all stainless steel closure bolts, lens tie rods, and attachment hardware for a complete and accepted installation.

Furnish and install Pier/Fender Lights, Center Channel Lights and Channel Margin Lights with cast aluminum or bronze swivel assembly and mounting bracket, complete with stainless steel pivot, watertight "O" ring seal, bronze bearings, cable entrance fitting, and stainless steel service chain rated for a minimum 225 pounds load. Use a 1-1/2 or 2 inch galvanized pipe or stainless steel pipe as a hanger stem with automatic lock at service and operating positions. Furnish and install a 60% counterweight if stem exceeds 5 feet in length.

Ensure the Pier/Fender Light is equipped with a red 180 degree lens, the Center Channel Light is equipped with a green 360 degree lens and the Channel Margin Light is equipped with a red 180 degree lens.

729-4.2 Clearance Gauge Lights: If required by the USCG, furnish and install one-piece die-cast aluminum fixture housing fitted with watertight gasket, stainless steel hinges and fasteners, and adjustable aiming capability, equipped with a 120 Vac, 50 watt, high-pressure sodium lamp. Use a heavy cast aluminum connection box body and cover with stainless steel swing bolts, watertight gasket and provisions for mounting to a platform with four stainless steel lag bolts or screws.

729-5 Disconnect Switches.

Furnish and install switches that are HP rated and meet Federal and NEMA Specifications with NEMA Type 4X (stainless steel) enclosures, and with metal factory nameplates that are front cover mounted and contain a permanent record of switch type, catalog number, and HP rating. Provide switch with visible blades, reinforced fuse clips, and nontearable, positive, quick make-quick break mechanisms. Provide switch assembly plus operating handle as an integral part of the enclosure base.

EXHIBIT 5 - SPECIAL PROVISIONS

Use switches with defeat able door interlocks that prevent the door from opening when the operating handle is in the ON position, and whose handle position is easily recognizable and is padlockable in the OFF position. Use heavy-duty switches with line terminal shields.

729-5.1 Fusible Switch Assemblies: Furnish and install NEMA KS 1 type; load interrupter enclosed knife switch. Provide fuse Clips that are designed to accommodate Class R fuses.

729-5.2 Non-fusible Switch Assemblies: Furnish and install NEMA KS 1; HD type, load interrupter enclosed knife switch.

729-5.3 Enclosures: Furnish and install NEMA KS 1 type enclosure.

729-5.4 Installation: Install disconnect switches where indicated in the Contract Document or where required by the Engineer. Use separate conduits for line and load conductors. Install fuses in fusible disconnect switches.

729-6 Supporting and Mounting Devices.

Ensure the sizes, and types of anchors, fasteners and supports used are adequate to carry the load of the equipment and conduit, including the wire in the conduit.

Space conduit supports to avoid conflicts with reinforcing steel at 5 feet maximum. For concrete mounting, use anchor bolts and all matching parts and tools recommended by and provided by the same manufacturer, as well as suitable for dynamic loading caused by vibration due to traffic. To mount conduit supports and pull boxes, use 1/4 inch diameter anchor system.

To mount channel lights use minimum 1/2 inch diameter anchor system with 3-1/2 inch embedment and 8 inch edge distance.

Use ASTM 300 series stainless steel conduit straps or hangers held at not less than two points.

Do not use powder-actuated anchors. Do not drill or weld structural steel members. Do not use bolts smaller than 1/4 inch in diameter except as may be necessary to fit the mounting holes in small and light devices. Install surface-mounted boxes with minimum of three anchors.

729-7 Conduit.

729-7.1 General: Furnish and install conduit in the quantities and sizes required to complete the work as shown in the Plans and as required by NEC. Use products listed and classified by UL as suitable for purpose specified and shown. Do not use non-metallic flexible conduit, aluminum, or electrical metallic tubing (EMT).

729-7.2 Liquid-Tight Flexible Metal Conduit: Furnish and install, liquid-tight flexible metal conduit of interlocked steel construction with PVC jacket, and fittings meeting the requirements of ANSI/NEMA FB 1.

729-7.3 PVC Conduit: Furnish and install, schedule 80 PVC 3/4 inch minimum diameter conduit meeting the requirements of ASTM D1785 and NEMA TC 2 and fittings and conduit bodies meeting the requirements of ASTM D2467 and NEMA TC 3.

729-7.4 Fiberglass Reinforced Epoxy Conduit: Furnish and install rigid non-metallic fiberglass reinforced epoxy conduit and fittings manufactured in accordance with the applicable standards of ANSI and NEMA TC-14B.

Ensure the conduit has a bell and spigot type coupling and the coupling seal is made rigid by using an adhesive that will provide a water and vapor tight joint with a tensile strength equal to that listed for the conduit. An alternative type assembly may be used by applying a triple seal ribbed gasket of water resistant rubber material. Ensure the gasket is held firmly in place with a compatible adhesive.

Ensure that all fittings, adapters, and bends are manufactured from the same materials as the conduit and conform to the dimensional requirements of NEMA TC-14.

Use only fiberglass reinforced epoxy conduit and fittings made by the same manufacturer to insure proper fit and assembly, listed on the UL approved list and labeled for Type I service sizes 2 to 6 inches.

Ensure that each piece of conduit and fitting is clearly marked with durable contrasting ink, stenciled with the following:

1. Nominal size,
2. Bends to show the degree and radius of curvature,
3. Type: SW or HW,
4. Manufacturers' name or trademark.

EXHIBIT 5 - SPECIAL PROVISIONS

729-7.5 Installation: Install conduit in accordance with National Electrical Contractors Association (NECA) "Standard of Installation" and manufacturer's instructions.

Arrange supports to prevent misalignment during wiring installation. Support conduit using straps, lay-in adjustable hangers, clevis hangers, and split hangers. Do not support conduit with wire or perforated pipe straps, plastic straps, or plastic hangers. Ensure that all wire used for temporary supports is removed upon completion of installation.

Install an expansion fitting for specified PVC conduit at all structure expansion joints or where movement between adjacent sections of conduit is expected. Provide certification to the Engineer from the manufacture that the expansion fitting meets the following minimum requirements: compatibility with the connected conduits, water proof, UV protected, and allows longitudinal movement equal to that of the expansion joint or movement expected.

Route exposed conduit parallel and perpendicular to walls or route conduit in the railings. Install conduits to be continuous and watertight between boxes or equipment. Protect conduits at all times from the entrance of water and other foreign matter by being capped or well plugged overnight and when the work is temporarily suspended.

Cut conduit square using saw or pipe cutter; de-burr cut ends. Bring conduit to shoulder of fittings; fasten securely. Use conduit hubs to fasten conduit to metal boxes. Do not install more than the equivalent of three 90 degree bends (total 270 degrees) between boxes. Use conduit bodies to make sharp changes in direction such as around diaphragms.

Join PVC conduit using cement recommended by manufacturer. Wipe PVC conduit dry and clean before joining. Apply full even coat of cement to entire area inserted in fitting. Allow joint to cure for a minimum of 20 minutes before pulling conductors.

Do not use flexible conduit extensions greater than 24 inches in length. Ensure that all flexible conduit extensions are equipped with bonding jumpers.

Do not allow moisture traps; provide pull box with drain fitting at low points in exposed conduit system.

729-8 Wiring.

729-8.1 General: Do not use aluminum conductors. Use only SE or RHW on incoming service and use single conductor with XHHW insulation, unless otherwise noted in the Plans.

Do not use wire smaller than No. 12 AWG.

Furnish insulated conductors of seven or nineteen strand copper with a minimum 98% conductivity and connector accessories for copper in sufficient quantities for a complete installation.

729-8.2 Installation: Use pull boxes wherever necessary to facilitate the installation of the conductors. Do not use condulets for pulling more than ten conductors or for branching conductors.

Splice only in accessible boxes. Make lug connections with high pressure indent connector tools as recommended by the lug manufacturer. Make splices and taps to carry full ampacity of conductors without perceptible temperature rise. Tighten all connections to manufacturer's recommendations. Tape uninsulated conductors and connectors with electrical tape to 150% of the insulation value of conductor. Ensure all splices are waterproof.

Use solderless pressure connectors with insulating covers for No. 8 AWG and smaller wire splices and taps. Use split bolt connectors for No. 6 AWG and larger wire splices and taps.

Pull all conductors into a raceway at the same time. Use soap base wire pulling lubricant for pulling No. 4 AWG and larger wire.

729-8.3 Testing: Test each circuit for continuity and short-circuits for its complete length before being connected to its load.

Inspect wire and cable for physical damage and proper connection.

EXHIBIT 6

SUPPLEMENTAL SPECIFICATIONS AND FORMS

SUPPLEMENTAL SPECIFICATIONS AND FORMS
FOR
Replacement of SC 41 Bridge over the Wando River
Charleston / Berkeley Counties

TABLE OF CONTENTS

SUPPLEMENTAL SPECIFICATIONS.....2

ERRATA TO 2007 STANDARD SPECIFICATIONS FOR HIGHWAY CONSTRUCTION2

CLAIMS PROCEDURE.....6

SOUTH CAROLINA MINING ACT10

CRITICAL PATH METHOD CONSTRUCTION SCHEDULES.....11

PROMPT PAYMENT CLAUSE.....16

AS-BUILT CONSTRUCTION PLANS17

TRANSPORTATION AND DELIVERY OF MIXES18

HIGH PRESSURE METHOD FOR REMOVAL OF PAVEMENT MARKINGS19

AUTOMATED FLAGGER ASSISTANCE DEVICE SYSTEM (AFAD).....21

DISTRICT 6 LANE CLOSURE RESTRICTIONS26

ADHESIVEVELEY BONDED ANCHORS AND DOWELS.....29

CONCRETE BATCHING AND MIXING.....33

CONCRETE STRUCTURES – PREFORMED JOINT FILLER34

GEOTEXTILE FOR DRAINAGE FILTRATION35

EROSION CONTROL MEASURES37

GROUT FOR POST TENSIONING AND PRESTRESSED CORED SLABS39

SEISMIC RESTRAINERS40

ELASTOMERIC CONCRETE FOR EXPANSION JOINT HEADERS.....46

CLAIM CERTIFICATION.....48

CONTRACTOR NOTICE OF CLAIM - FORM 616.....49

PILE AND DRIVING EQUIPMENT DATA FORM.....50

DRILLED SHAFT FORMS51

TRAFFIC SIGNAL SUPPLIMENTAL SPECIFICATIONS AND FORMS.....75

ERRATA TO 2007 STANDARD SPECIFICATIONS FOR HIGHWAY CONSTRUCTION

Make the changes listed below to correct errata in the SCDOT 2007 *Standard Specifications for Highway Construction*:

DIVISION 100 GENERAL PROVISIONS

SECTION 101 DEFINITIONS AND TERMS

Subsection 101.2 Abbreviations and Acronyms

Amend the table of **SCDOT OFFICIALS AND OFFICES** as follows:

DELETIONS		REPLACEMENTS	
BDE*	Bridge Design Engineer	PSE*	Preconstruction Support Engineer
BDGE*	Bridge Design Geotechnical Engineer	GDSE*	Geotechnical Design Support Engineer
SHE*	State Highway Engineer	DSE*	Deputy Secretary for Engineering

*Wherever it appears in the text, replace the deleted abbreviation with the new abbreviation.

SECTION 102 BIDDING REQUIREMENTS AND CONDITIONS

Subsection 102.8 Irregular Bids

Paragraph 2, item E, first sentence; delete the word "the" after the word "When".

SECTION 105 CONTROL OF WORK

Subsection 105.6 Cooperation with Utilities

Paragraph 1, last sentence; change the word "THE" to "the".

DIVISION 200 EARTHWORK

SECTION 202 REMOVAL OF STRUCTURES AND OBSTRUCTIONS

Subsection 202.5 Measurement

Paragraph 5, second bullet; change the words "Brick sidewalk" to "Concrete, brick or stone sidewalks".

SECTION 204 STRUCTURE EXCAVATION

Subsection 204.2.1.2 Structure Excavation for Culverts

Paragraph 1, at the end of the first sentence; change "**Subsection 204.4**" to "**Subsection 204.5**".

DIVISION 400 ASPHALT PAVEMENTS

SECTION 401 HOT MIXED ASPHALT (HMA) PAVEMENT

Subsection 401.2.1.2 Liquid Anti-Stripping Agent

Paragraph 1, first sentence; delete the period at the end of the sentence and add "and SC-M-406."

Subsection 401.2.5 Material for Full Depth Patching

Paragraph 1, delete and replace with the following:

"Use an approved SCDOT Intermediate Type C mix for all Full Depth Patching."

Subsection 401.5 Measurement

After paragraph 10, add the following paragraph:

- 11 The measurement of Prime Coat is the number of gallons of asphalt material applied to the completed and accepted base course.

Subsection 401.6 Payment

After paragraph 12, add the following paragraph:

- 13 "The payment for Prime Coat is at the contract unit price for Prime Coat and includes compensation for all labor, equipment, tools, maintenance, and incidentals necessary to complete that work."

Subsection 401.6 Payment

Paragraph 13, **Table of Pay Items**

Change paragraph reference number "13" to "14" and add the following Pay Item:

Item No.	Pay Item	Unit
4010005	Prime Coat	GAL

SECTION 403 HMA SURFACE COURSE

Subsection 403.5 Measurement

Paragraph 1, first sentence; change "HMA Intermediate Course" to "HMA Surface Course".

Subsection 403.6 Payment

Paragraph 1, first sentence; change "HMA Intermediate Course" to "HMA Surface Course".

SECTION 407 ASPHALT SURFACE TREATMENT – DOUBLE TREATMENT

Subsection 407.5 Measurement

Paragraph 1, first sentence; add the word "is" after "(Double Treatment Type (1, 2, 3, 4, or 5))".

SECTION 408 ASPHALT SURFACE TREATMENT – TRIPLE TREATMENT

Subsection 408.5 Measurement

Paragraph 1, first sentence; add the word "is" after "(Triple Treatment Type (1 or 2))".

DIVISION 600 MAINTENANCE AND TRAFFIC CONTROL

**SECTION 625 PERMANENT PAVEMENT MARKINGS
FAST DRY WATERBOURNE PAINT**

Subsection 625.2.2.4.11 Lead Content

Paragraph 1, first sentence; change 6% to 0.06%.

SECTION 627 THERMOPLASTIC PAVEMENT MARKINGS

Subsection 627.4.10 Inspection and Acceptance of Work

Paragraph 2, first sentence; change "period of 90 days" to "period of 180 days".

Subsection 627.4.10 Inspection and Acceptance of Work

Paragraph 2, second sentence; change "90-day observation period" to "180-day observation period".

Subsection 627.4.10 Inspection and Acceptance of Work

Paragraph 3, first sentence; change "90-day period" to "180-day period".

DIVISION 700 STRUCTURES

SECTION 709 STRUCTURAL STEEL

Subsection 709.4.3.5.2 Submittals and Notification

Paragraph 1, delete the last two sentences and replace them with, "The Department's review and acceptance are required before any field welding will be permitted."

Subsection 709.6.3 Pay Items (page 650)

Subsection heading number; change subsection heading number from "709.6.3" to "709.6.4".

SECTION 712 DRILLED SHAFTS AND DRILLED PILE FOUNDATIONS

Subsection 712.4.4 Dry Construction Method

Paragraph 2, last sentence in A; change "*Drilled Shaft Report*" to "*Drilled Shaft Log*".

Subsection 712.4.10.4 Excavation Cleanliness

Paragraph 1, last sentence; change "*Drilled Shaft Report*" to "*Drilled Shaft Log*".

Subsection 712.4.10.6 Shaft Load Test

Change first paragraph reference number from "2" to "1".

Subsection 712.6.10 Drilled Pile Set-Up

Insert paragraph reference number "1" to the left of the first paragraph.

SECTION 723 DECK JOINT STRIP SEAL

Subsection 723.1 Description

Insert paragraph reference number "3" to the left of the third paragraph.

SECTION 726 BRIDGE DECK REHABILITATION

Subsection 726.4.1 General

Insert paragraph reference number "1" to the left of the first paragraph.

Subsection 723.4.6 Full Depth Patching (page 790)

Subsection heading number; change subsection heading number from "723.4.6" to "726.4.6"

SECTION 727 CROSSHOLE SONIC LOGGING OF DRILLED SHAFT FOUNDATIONS

Subsection 726.6 Payment (page 807)

Subsection heading number; change subsection heading number from "726.6" to "727.6"

DIVISION 800 INCIDENTAL CONSTRUCTION

SECTION 805 GUARDRAIL

Subsection 805.5 Measurement

Paragraph 4; amend as follows:

"The quantity for the pay item 8053000 Additional Length Guardrail Post is the length of required post installed in excess of the standard length post based on the system being installed, measured by the linear foot (LF), complete, and accepted."

SECTION 815 EROSION CONTROL

Subsection 815.1 Description

Paragraph 1, first sentence; change "temporary flexible pipe" to "temporary pipe".

Subsection 815.5 Measurement

Paragraph 13; delete the first sentence and replace it with the following sentence:
"The quantity for Temporary Pipe Slope Drains is measured and paid for in accordance with **Subsections 803.5** and **803.6** respectively."

Subsection 815.5 Measurement

Delete paragraph 19.

Subsection 815.6 Payment

After paragraph 15, add the following paragraph:

- 16 Payment for Removal of Silt Retained by Silt Fence is full compensation for removing and disposing of sediment deposits accumulated by silt fences as specified or directed and includes all materials, labor, equipment, tools, supplies, transportation, and incidentals necessary to fulfill the requirements of the pay item in accordance with the Plans, the Specifications, and other terms of the Contract.

Subsection 815.6 Payment

Change original paragraph number "16" to "17".

Subsection 815.6 Payment

Pay Item table; change the Unit for Item No. 8156214 to "EA".

INDEX:

Amend as follows:

Page I-3, after "Bridge Deck Rehabilitation, measurement and payment:"
Delete page 807.

Page I-12, after "Letting:"
Replace page 19 with page 9.

Page I-13, after "Overhead Sign Structure:"
Replace page 488 with page 495.

Page I-15, after "Proof Rolling:"
Delete page 98.

Page I-18, after "Structural Steel, turned and ribbed bolts:"
Replace page 624 with page 625.

Page I-19, after "Waterproofing, bridge deck:"
Delete page 907.

Page I-20, after "Working Drawings:"
Replace page 543 with page 779.

February 12, 1997

CLAIMS PROCEDURE

1. Scope of Procedure

The following claims procedure covers all claims for additional time or compensation arising under this contract. The claims procedure is non-binding and is a condition precedent to litigation or any other form of dispute resolution. All communications testimony and all documents prepared for this procedure by either party from the time of filing the claims request to the conclusion of the procedure shall be deemed to be settlement negotiations and not admissible in litigation or any other dispute resolution procedure. The parties shall execute a written agreement to this effect prior to the submission of testimony or other evidence before the Dispute Review Board.

2. Continuation of Work

At all times during the pendency of a claim under this procedure, the contractor shall continue work pursuant to the contract and as directed by the engineer as provided by the contract. If the contractor fails to continue work, it may be declared delinquent in its work as provided by §108.08 of the South Carolina Standard Specifications for Highway Construction ("Standard Specifications").

3. Submission of Claim

The notice of claim and claim shall be submitted in accordance with §105.16 of the Standard Specifications. The notice of claim does not trigger this claims procedure. The claims procedure is initiated when the contractor submits a written fully detailed claim to the resident construction engineer ("RCE"). The claim shall contain, at a minimum, the information required by §105.16F of the Standard Specifications. The RCE shall immediately forward a copy of the claim to the District Engineering Administrator ("DEA") for resolution. If the DEA is unable to resolve the claim within thirty (30) days of receipt, the DEA shall forward it immediately to the Director of Construction ("DC"), together with documents supporting the Department's position. The DEA shall also submit the supporting documents to the contractor at this time. The DC shall investigate the claim and attempt to resolve it by mutual agreement with the contractor. If it cannot be resolved, then the DC shall make a decision and forward it to the contractor, no later than thirty (30) days after receipt by the DC. The contractor shall notify the DC within five (5) days of receipt of the DC's decision whether the contractor accepts or rejects the decision.

For all claims under Fifty Thousand Dollars (\$50,000.00) the DC's decision shall be final and shall conclude the claims procedure. For the purpose of determining if a time only claim may be submitted to the Board, the value of a time only claim shall be deemed to be the number of days requested multiplied by the contract daily rate for liquidated damages. The contractor does not have a right to submit claims under \$50,000.00 to the Dispute Review Board. If the contractor does not accept the DC's decision on its claim of less than \$50,000.00, then its remedy is litigation or other mutually agreeable dispute resolution procedures.

For all claims in excess of \$50,000.00, if the contractor rejects the DC's decision or fails to respond to the decision, the DC shall forward the claim to the Dispute Review Board.

4. Dispute Review Board

On designated contracts an *Ad Hoc* Dispute Review Board will be established to hear claims on that contract. On other contracts, claims will be heard by a Standing Dispute Review Board. All Board Members shall be neutral and unbiased. No party shall have any *ex parte* communication with any Board Member.

a. Ad Hoc Dispute Review Board

On designated contracts a Dispute Review Board shall be established within sixty (60) days after the Preconstruction Conference. The *Ad Hoc* Dispute Review board shall consist of one member selected by the Department, one member selected by the contractor, and a third member selected by the first two members. The third member shall be the chairperson of the *Ad Hoc* Dispute Review Board. The selection of qualified *Ad Hoc* Dispute Review Board members

shall be made in accordance with the Dispute Review Board rules and procedures. (See Section 6).

b. Standing Dispute Review Board

A Standing Dispute Review Board shall be established upon implementation of this claims procedure. The Standing Dispute Review Board shall consist of one member selected by the Department, one member selected by the Director of Heavy and Highway Division of the Associated General Contractors (Carolina's Branch), and a third member selected by the first two members. The third member shall be the chairperson of the Standing Dispute Review Board. The selection of qualified Standing Dispute Review Board members shall be made in accordance with the Dispute Review Board rules and procedures. (See Section 6). Each member shall serve a three (3) year term and the terms shall be staggered. The terms for the initial Board members shall be as follows:

Department Member - 1 year
AGC member - 2 years
Third member - (Chairperson) 3 years

The term for the initial members begins January 1997. Each member is limited to two (2) terms. The initial abbreviated terms of the Department and AGC members do not count as a term.

5. Hearing Procedure

When the DC forwards the claim to the Dispute Review Board, the DC shall provide three (3) copies of the claim and three (3) copies of all documents submitted by the contractor and the DEA. The DC shall notify both parties that the claim has been submitted to the Board.

Within fifteen (15) days of notice of submission of the claim to the Board, the contractor may submit to the DC four (4) copies of any additional documentation supporting its claim. The DC shall immediately forward three (3) copies to the Board and one (1) copy to the DEA.

Within fifteen (15) days of receipt of the contractor's supplemental documentation, the DEA may submit to the DC four (4) copies of its additional documentation. The DC shall immediately submit three (3) copies to the Dispute Review Board and one (1) copy to the contractor. Upon submission of supplemental documentation, the party shall notify the Board whether it requests a hearing.

The Dispute Review Board shall review all documents and notify the parties of what additional documents, if any, it requires. The Dispute Review Board shall schedule a hearing at either party's request or may schedule a hearing at its own discretion. However, if a hearing is requested, it must be held no later than sixty (60) days after the DC submits the claim to the Dispute Review Board. The location of the hearings shall be determined by the Board. While extensions of these deadlines are discouraged, the Dispute Review Board shall have authority to extend any of the above deadlines for just cause.

The Dispute Review Board shall have full authority to establish guidelines and procedures for the investigation of a claim. The entire process is intended to be flexible and the Board is encouraged to adapt the process to individual circumstances presented by particular disputes.

In the interest of timely resolution of all claims, the Board shall conduct all hearings and issue its final decision within ninety (90) days of receipt of the claim.

The Dispute Review Board Chairperson shall direct all meetings and hearings. Presentation of evidence shall be in accordance with the Dispute Review Board's rules and shall not be bound by judicial rules of evidence. Documents and testimony shall be presented in the order, manner and degree of detail that the Dispute Review Board deems most efficient and probative. Each party shall be allowed to make a brief initial presentation and to rebut any factual assertion by another party; however, the Dispute Review Board shall determine when enough evidence has been presented and it may limit the presentation of any documentation or testimony that it deems not relevant or redundant. At the Board's

option, testimony may be required to be given under oath and the oath shall be administered by the Chairperson.

Legal counsel for either party may be present at meetings or hearings as observers only. If a party intends to have its counsel present at a hearing, it must provide at least ten (10) days notice prior to the meeting or hearing. Legal counsel may not speak on behalf of a party, unless requested by the Board. Counsel may not examine or cross-examine witnesses, object to questions or statements during meetings or make legal motions or arguments during meetings or hearings. The Board, by majority vote, may suspend legal counsel's privilege to attend meetings or hearings.

The Dispute Review Board shall issue to the contractor and the State Highway Engineer a written recommendation with an explanation of the results as soon as reasonably possible following the conclusion of the hearing. However, in no event shall the Board take more than ninety (90) days from receipt of claim to conduct hearings and issue a recommendation. The Board is encouraged to reach a unanimous decision; however, it may provide a majority recommendation. The minority Board Member may provide a written explanation of his position. The Board shall provide further explanation of its decision if requested by either party within ten (10) days of the receipt of the decision. Issuance of the Board's recommendation concludes the claims procedure.

The parties may settle at any time during the procedure. If the dispute is resolved prior to issuance of a recommendation, the DC shall immediately notify the Board.

6. Dispute Review Board Rules and Procedures

a. Qualifications of Dispute Review Board Members

(1) All Dispute Review Board Members shall have substantial experience in highway or bridge design and construction. This experience may be technical, administrative or legal. The goal is to have a Board with the technical and administrative skills and experience that will promote confidence in its decisions.

(2) No Dispute Review Board Member shall be employed currently or within the last three (3) years with the Department, any contractor (currently or in the past pre-qualified with the Department), or any design consultant that has worked for the Department within the last three (3) years.

(3) No Dispute Review Board Member shall have any financial or ownership interest in any party to the contract nor any design consultant or major subcontractor.

b. Selection of Dispute Review Board Members

(1) Ad Hoc Dispute Review Board

Within twenty (20) days after the Preconstruction Conference, the contractor and Department shall each submit a list of three (3) proposed Dispute Review Board Members to each other.

The contractor shall send its list to the DC. The Department shall send its list to the contractor's designated representative. Within ten (10) days after receipt of the list, the contractor shall select one member from the Department's list and the Department shall select one member from the contractor's list and notify the other party of their selection. The DC shall notify the two selected members that they must select a third member within twenty (20) days. The DC shall also provide a copy of the claims procedure to the two (2) selected members. Within twenty (20) days of the selection of the first two members, the first two members shall select the third member and the third member shall be the chairperson of the Dispute Review Board. The third member does not have to come from the lists provided by the parties.

If the first two members are not able to agree on a third member within twenty (20) days of their selection, then the third member shall be selected by the American Arbitration Association, within ten (10) days after it is determined that the first two members cannot agree on a third member. Upon selection of the third member, the DC shall provide a copy of the claims procedure to the third member.

(2) Standing Dispute Review Board

The selection process for Standing Dispute Review Board Members shall begin at the appropriate time in order to allow completion of the Member selection by beginning of the term. The selection process shall be as provided in Section 4(b); otherwise it shall be the same as for the *Ad Hoc* Board.

c. Replacement of Board Members

Each party may elect to replace its Board Member at any time with a showing of reasonable justification. The Chairperson of the Board may be replaced at any time with the consent of both parties. If any Board Member is replaced, the new member shall be selected in the same manner in which the original appointment had been made.

If disputes are pending at the end of a member's term, the existing Board shall complete its hearing on the disputes and issue a decision.

d. Costs

Board Members shall be paid a reasonable hourly rate or salary for their services. Each party shall negotiate the fee arrangements with the Member it selects, however, the other party must agree on the rate. Both parties shall agree on the fee arrangement for the Chairperson.

Board Members shall be reimbursed for out-of-pocket expenses including, but not limited to, travel, copying, telephone, clerical services, and mailings. The Board Members shall be allowed \$55.00 per diem for meals and actual lodging costs provided they stay in hotels approved by the Department and they obtain a government rate. Board Members must provide documentation for all expenses.

The parties shall share all Board Members' fees and expenses equally. The total fees and expenses to hear each claim shall not exceed the following maximum amounts (one claim shall constitute all issues submitted to the Dispute Review Board at one (1) time):

\$ 50,000 - \$499,999.99	\$10,000.00
\$500,000.00 - \$999,999.99	\$15,000.00
\$1 million - \$4,999,999.99	\$25,000.00
over \$5 million	\$50,000.00

The Department shall pay the Board Members and deduct the Contractor's share from the retainage. If retainage is not sufficient, the Contractor shall pay the Department directly for its share of the fees and expenses.

March 20, 2003

THE SOUTH CAROLINA MINING ACT

The South Carolina Mining Act enacted by the General Assembly in 1973 requires that the Department adopt reclamation standards to govern activities of the Department and any person acting under contract with the Department, on highway rights-of-way or material pits maintained solely in connection with the construction, repair and maintenance of the public road systems in South Carolina.

STANDARD PLAN FOR THE RECLAMATION OF EXCAVATED AREAS ADOPTED BY THE SOUTH CAROLINA DEPARTMENT OF TRANSPORTATION

Reclamation plans as stated herein shall include all areas disturbed in excavations of borrow and material pits, except planned inundated areas.

The final side slopes of areas excavated for borrow and material pits shall be left at such an angle so as to minimize erosion and the possibility of slides. The minimum slope in every case shall be not less than 3:1.

Small pools of water that are, or are likely to become noxious, odious, or foul should not be allowed to collect or remain on the borrow pit. Suitable drainage ditches, conduits, or surface gradient shall be constructed to avoid collection of noxious, odious, or foul pools of water unless the borrow pit is to be reclaimed into a lake or pond.

Borrow pits reclaimed to a lake or pond must have an adequate supply of water to maintain a water sufficient level to maintain a minimum water depth of four (4) feet on at least fifty (50) percent of the surface area of the lake or pond.

Excavated areas will be drained where feasible unless otherwise requested by the property owner where, in such instances, the property owner may wish to develop the excavated area for recreational purposes or for the raising of fish, or for other uses, in compliance with the South Carolina Mining Act.

Where material is stripped from the ground surface in relatively thin layers, the area, after excavation has been completed, will be thoroughly scarified and terraced and planted to establish satisfactory vegetation necessary to control erosion. Vegetative cover should be established on a continuing basis to ensure soil stability appropriate to the area. Conservation practices essential for controlling both on-site and off-site erosion and siltation must be established. A minimum of seventy-five (75) percent vegetative ground cover, with no substantial bare spots, must be established and maintained into the second growing season.

Excavated areas that are drained will be seeded to obtain a satisfactory vegetative cover. The side slopes of excavated area will be planted to vegetation.

The State Highway Engineer, or his duly appointed representative, will make a final inspection of the reclaimed area and keep a permanent record of his approval thereof. A map or sketch providing the location and approximate acreage of each pit used on the project will be made available to the Final Plans Engineer.

All applicable regulations of agencies and statutes relating to the prevention and abatement of pollution shall be complied with by the contractor in the performance of the contract.

The Contractor shall comply with the provisions of the Plan which are applicable to the project as determined by the Engineer. Seeding or other work necessary to comply with the plan on pits furnished by the contractor shall be at the expense of the contractor. Bermuda shall not be planted on ground surface pit areas. The quantity of fescue seed specified in Subsection 810.04 of the Standard Specifications shall be increased by fifteen (15) pounds in lieu of the deleted bermuda seed.

March 1, 2007

CRITICAL PATH METHOD CONSTRUCTION SCHEDULES

General

This supplemental specification addresses the Critical Path Method (CPM) construction schedule requirements for SCDOT contracts. The Contractor will provide and update a construction schedule to the SCDOT, which will be used as a quantitative basis for:

- Monitoring and evaluating the Contractor's progress in completing contracted work;
- Evaluating requests for additional contract time;
- Budgeting for construction estimate payments; and
- Managing SCDOT engineering and inspection personnel.

The Contractor's construction schedule shall encompass the entire contract period, and be developed consistent with the contract milestones and the contract maintenance of traffic plan. Critical path activities shall be identified for the duration of the work.

The schedule shall reflect the utility relocations noted in the contract documents and include activities of appropriate duration for the utility adjustments. Where utility durations are unknown, the Contractor shall provide a reasonable estimate of duration. Utility durations will be reviewed in the baseline approval process as outlined in the section "Submission, Review, and Acceptance Process." Utility durations will be presented at the Preconstruction Conference for concurrence by the utility provider. In the event that the utility representative cannot provide concurrence at the Preconstruction Conference, the Contractor, the Resident Construction Engineer, and the utility provider shall work diligently to reach acceptable durations. If there is no concurrence or input from the utility provider concerning the Contractor's utility durations within 15 days following the Preconstruction Conference, the submission with the Contractor's estimate of utility duration will be reviewed for baseline acceptance. Further utility duration changes beyond this point in time will be assessed in monthly schedule updates. Failure to include activities for any element of work or any known utility work will not relieve the Contractor from completing the work within the allotted contract time.

The schedule shall also include sufficient information *as outlined in this supplemental specification* to provide for monetary and quantitative tracking of the work by the SCDOT.

Schedule Types

Contractors shall maintain CPM schedules for all projects using Primavera 5.0 (or current version) or Primavera Contractor.

Templates for the CPM schedules are available to download at [the](http://www.scdot.org/doing/const_extranet.shtml) the SCDOT construction Extranet site (http://www.scdot.org/doing/const_extranet.shtml).

When submitting schedules to the SCDOT, the Contractor shall assign file names to each schedule file (baseline and updates) according to the following conventions (dates are YYMMDD):

Type of Schedule Submitted:	Baseline	Update
File Name Convention:	[File Number]b[Data Date]	[File Number]u[Data Date]
File Name Example:	32.82571b060201	32.82571u060201

Note on Data Dates - The initial Baseline Construction Schedule shall have a data date equal to the date of submission of the schedule and not include any work to date. Monthly schedule updates shall have a data date set the same as the most recent estimate period end date.

Schedule Submissions

All submissions shall be made within the time frames defined under "Submission, Review and Acceptance Process."

Electronic File: Each baseline construction schedule and monthly update submission shall be uploaded to the SCDOT Construction Extranet site in .xer format. The site can be found at: (http://www.scdot.org/doing/const_extranet.shtml)

Hard Copies: A hard copy of each baseline construction schedule and monthly update submission shall be provided to the District Scheduler and the Resident Construction Engineer. Printout shall include the following columns on 11 inch x 17 inch paper: Activity ID, Activity Name, Early Start, Actual Start, Early Finish, Actual Finish, Schedule % Complete, Physical % Complete, Budgeted Total Cost, Actual Total Cost, Original Duration, Remaining Duration, and Total Float.

Schedule Narrative: Submit a Schedule Narrative Report with the baseline and each monthly update schedule describing current project schedule status and identifying potential delays. This report will include a description of the progress made since the previous schedule submission and objectives for the upcoming 30 calendar days.

- 1) The report shall indicate if the project is *on schedule*, *ahead of schedule* or *behind schedule* as compared to the accepted baseline. If the project is ahead of schedule or behind schedule, the report shall include the specific number of calendar days. If the project is behind schedule, the report shall include a detailed recovery plan that will put the project back on schedule.
- 2) The report will describe the *current critical path* of the project including the lowest total float value and indicate if this has changed in the last 30 calendar days. Discuss current successes or problems that have affected either the critical path's length or have caused a shift in the critical path within the last 30 calendar days. Identify specific activities, progress, or events that may reasonably be anticipated to impact the critical path within the next 30 calendar days, either to affect its length or to shift it to an alternate path.
- 3) List all schedule logic or duration changes that have been made to the schedule since the previous submission. Provide an explanation for any *constraint* used. For each change, describe the basis for the change and specifically identify the affected activities by identification number.
- 4) Identify activities, either in progress or scheduled to occur within the following 30 days, that require Department participation, review, approval, etc.
- 5) Identify any calendars used that are not DOT specific, and explain the details of those calendars.
- 6) Identify schedule settings used.
- 7) An explanation of lag for each activity lag is associated with.
- 8) Description of how the schedule is organized (e.g. broken down by road or activity).
- 9) Narrative will be submitted with a naming convention of [File Number]n[Data Date].doc (e.g 32.82571n060201.doc). Contractor will upload the electronic copy [in .doc format] to the South Carolina Department of Transportation Construction Extranet site (http://www.scdot.org/doing/const_extranet.shtml).

Schedule Details

Data Date - The Baseline Construction Schedule shall have a data date equal to the date of submission of the schedule and not include any completed work to date. Monthly schedule updates shall have a data date set the same as the most recent estimate period end date.

Milestones - Schedule shall identify the following milestones as a minimum:

- **Notice to Proceed Date (NTP):** Issuance of this date indicates the project site is available to the Contractor and contract time has begun. The NTP is determined in coordination between the Engineer and the Contractor and shall be within 45 days of the Award Date unless extenuating circumstances warrant setting the NTP more than 45 days after the Award Date. Include any extenuating circumstances in the narrative. The Notice to Proceed Date shall be the first milestone in the schedule.
- **Work Begin Date:** Actual date that on-site work commences.
- **Interim Completion Dates or Interim Milestones:** When interim completion dates or interim milestones (associated with project stages) are included in the contract specifications.
- **Start of Paving:** Date paving production and placement is to start.
- **Substantial Work Complete Date:** Anticipated date that work will be substantially complete. Facility will be available for the safe and convenient use of motorists; only allowable work remaining at substantial completion is placement of permanent pavement markings and resolution of punch list items.
- **Contract Completion Date:** Date defined by the Department as the latest date for contract completion. This is the last milestone and will establish the finish date of the project schedule. The schedule may indicate a completion date in advance of the contract completion date. However, the Department will not be liable for the Contractor's failure to complete the project prior to the Contract Completion Date. Any additional costs, including extended overhead incurred between the Contractor's schedule completion date and the completion of the contract time, shall be the responsibility of the Contractor.

Activities – Each Activity shall be part of the logic driven network and include a predecessor (excepting the first activity) and a successor (excepting the last activity). Each activity duration shall be limited to 30 days. As a minimum, the schedule shall include the following activities when related work is part of the contract, but there shall be sufficient detail in included activities to determine monthly progress of work and forecast of inspection and cost. The Contractor shall use the Activity Codes provided in the template for organizing activities. Activities for deliverables and reviews shall be included in the schedule.

- **Mobilization:** preparations for and moving of equipment, etc., to the project site.
- **Clearing & Grubbing:** Self-explanatory.
- **Utility Relocations:** The schedule must reflect the utility relocations noted in the contract documents and include activities of appropriate duration for the utility adjustments. Where utility durations are unknown, the Contractor shall provide a reasonable estimate of duration.
- **Earthwork:** Unclassified & borrow excavation, compaction, fine grading, etc.
- **Drainage:** Pipe, catch basins, manholes, etc.
- **Base Course:** Graded aggregate base courses, cement modified bases, etc.
- **Paving:** Hot mix asphalt base, intermediate, and surface courses; Portland cement concrete pavements, etc.
- **Structures:** Bridges, box culverts, retaining walls, etc.

The Department requires retained logic be used in scheduling projects. In situations where a Contractor has to address activities out of sequence, the Contractor may request to use the "progress override" option. The monthly schedule update narrative shall provide justification for selecting this option and quantify any logic change(s).

Resources – The Department will not require any input to the resource component of the schedule by the Contractor.

Expenses – Contractor shall assign the SCDOT contract items as expenses to each activity. SCDOT contract items will be included as Expense Categories and will be made part of the SCDOT schedule template available to download from the construction Extranet site. These shall be the only expense categories associated with activities. Other fields under expenses that shall be populated include Budgeted Units, Price/Unit, and Actual Units.

Calendars – Contractor shall assign an appropriate SCDOT calendar to each activity in the schedule. Alternate calendars may be assigned, but specifics of the alternate calendars must be justified in the baseline narrative. Contractor shall assign all calendars as project specific. Acceptance of the alternate calendars is subject to review by the SCDOT. Considerations for weather shall be addressed within the activities – calendars shall not be modified to account for weather considerations. Calendars have been created to address established seasonal restrictions.

The Baseline Construction Schedule shall not extend beyond the number of working days or contract completion date originally provided in the contract.

Cost Loading – All schedule activities shall be cost loaded using the contract items and unit prices under “Expenses” in Primavera.

Float – Float is not for the exclusive use or benefit of either the Department or the Contractor. Initial baseline schedules shall not attribute negative float or negative lag to any activity.

Schedule Layout – Schedule shall be structured consistent with the phasing and staging noted in the contract documents. Activity Codes for area and stage are included in the template. These codes shall be used to organize each activity included in “Schedule Details – Activities” as appropriate to provide a detailed schedule layout. Activities shall not be allowed to cover more than one stage of the contract.

Default Values – Contractor shall use the following defaults, physical percent complete, retain logic, and longest path critical activities.

Submission, Review and Acceptance Process

Baseline Schedule – Contractor shall submit a Critical Path Method (CPM) Contract Schedule and Narrative to the District Scheduler within 30 calendar days after award of the Contract or 15 days prior to the preconstruction conference, whichever is earlier. The CPM Schedule and Narrative shall be submitted via upload to the Extranet. Upon upload, the Contractor shall immediately notify the District Scheduler and the Resident Engineer via email that the CPM schedule has been submitted.

Upon receipt of the CPM Construction Schedule, SCDOT shall review and provide comments to the Contractor within 10 days of receipt. The Contractor will have 5 business days to respond to SCDOT comments. This process will continue until the Engineer and the District Scheduler determine the construction schedule is acceptable.

The Contractor shall present their accepted schedule at the Preconstruction Conference. In the event the schedule has not been accepted (i.e. review process is ongoing), the most current schedule under review shall be presented.

Acceptance of the submitted schedule by the SCDOT will establish the baseline schedule for the contract. This acceptance by SCDOT does not serve to excuse any omissions or errors in the Contractor's schedule (i.e. activities not included in baseline will not be considered in any time extensions).

Review and acceptance of baseline schedule is required prior to start of work. Delays in reaching this acceptance will not constitute a basis for granting additional contract time. If there is no concurrence or input from the utility provider concerning the Contractor's utility durations within 15 days following the Preconstruction Conference, the submission with the Contractor's estimate of utility duration will be reviewed for baseline acceptance. Further utility duration changes beyond this point in time will be assessed in monthly schedule updates.

Monthly Updates – Monthly updates shall be made no later than 15 days following the most recent estimate and shall have a data date the same as the estimate period end date. Upon upload, the Contractor shall immediately notify the District Scheduler and the Resident Engineer via email that the CPM schedule has been submitted. Failure to submit acceptable schedule updates as required will result in the withholding of estimate payments. Updates shall include the following:

- Updated schedule to show actual progress on activities
- Updated schedule to show actual costs on activities
- Updated schedule to show actual completion on milestones
- Narrative to describe progress, planned activities, issues, adjustments to remedy any activities or milestones behind schedule, etc., in the format described in **Schedule Submissions**.

As-Built Schedule – A final As-Built Schedule shall be submitted within 45 days following substantial completion of the work or within 15 days following the contract completion, whichever is later.

Baseline Schedule Changes – Once the baseline schedule has been accepted, all subsequent schedules provided will be considered schedule updates and compared to the original baseline. A new baseline will only be considered when significant changes in contract scope, changes in SCDOT priorities, or delays beyond the control of the Contractor occur.

If a baseline change is needed, the Contractor shall provide, in writing, a request to the Resident Construction Engineer with the following information:

- An electronic copy of the proposed baseline schedule using the following naming convention and in accordance with **Schedule Types** (included previously)

Type of Schedule Submitted:	Updated Baseline
File Name Convention:	[File Number]ub[Data Date]
File Name Example:	32.82571ub060201

- Narrative identifying changes warranting a new baseline

A decision for an updated baseline will be made jointly between the Resident Engineer and the District Scheduler within 10 days of receipt of request.

Measurement and Basis of Payment

The Department will make partial payments according to Section 109, Standard Specifications for Highway Construction, and as modified by the following schedule:

Basis of Payment	Percentage of Contract Unit Price of Item
After the Engineer has approved the CPM Baseline schedule	60
After the Engineer has approved the As-Built CPM schedule	40

The Department will pay for the accepted quantities at the contract price as follows:

Item	Description
1080300	CPM Progress Schedule

PROMPT PAYMENT CLAUSE

- (1) Subject to the provisions on retainage provided in Paragraph (2) below, when a subcontractor has satisfactorily performed a work item of the subcontract, the Contractor must pay the subcontractor for the work item within seven (7) calendar days of the Contractor's receipt of payment from SCDOT. A subcontractor shall be considered to have "satisfactorily performed a work item of the subcontract" when the SCDOT pays the Contractor for that work item.
- (2) The Contractor may withhold as retainage up to five (5%) percent of a subcontractor's payment until satisfactory completion of all work items of the subcontract. "Satisfactory completion of all work items of the subcontract" shall mean when the SCDOT accepts the last work item of the subcontract. The Contractor must release to the subcontractor any retainage withheld within seven (7) calendar days from the date the Contractor receives payment from SCDOT for the last work item of the subcontract or within seven (7) days from SCDOT's acceptance of the last work item of the subcontract, whichever is the latest to occur. However, upon documentation of good cause provided by the contractor and written concurrence by the Director of Construction, the Contractor may continue to withhold the 5% retainage.
- (3) Prior to receiving payment of each monthly estimate, the Contractor shall certify to SCDOT that the construction estimate is complete and that all subcontractors have been paid for work covered by previous estimates, in accordance with sections 1 and 2.
- (4) Failure to comply with any of the above provisions shall result in one or more of the following sanctions: (1) no further payments to the Contractor unless and until compliance is achieved; (2) the Contractor being placed in default; and/or (3) the Contractor being declared delinquent, such delinquency being subject to procedures and penalties provided in 108.08 of the Standard Specifications.

April 1, 2008

AS-BUILT CONSTRUCTION PLANS

Removed from checklist 12-17-08

GENERAL

The Contractor shall produce and deliver to the Department the final As-Built plans for this contract. This set of As-Built plans is not intended to document final quantities, but is intended to show approved revisions to the contract design including but not limited to: revised roadway profiles and cross sections, revised typical sections, revised drainage installations, any changes to the demolition and removal items and any other changes to the original design.

If any design changes occur during construction, the plan sheets (or any other "job site record document" with a seal) revised after award of contract shall include a complete accounting and detail of the revisions and design changes. The P.E. responsible for the revisions shall seal each altered plan sheet (or any other "job site record document" with a seal). This documented information is to be part of the As-Built Plan requirements.

The As-Built plans shall be neat, legible and of the correct size. Bridge projects and any road projects which include Plan, Profile and Cross-Section Sheets shall be full size. In general, if the job was let with full size plans (22" X 36"), the As-Built shall be full size. All revisions to the original plans shall be delineated in red ink, located properly on the drawing, they shall be legible and true to scale. Every As-Built Plan, Profile and Cross-section Sheet shall be designated as such by note or stamp "As-Built" in red. The As-Built Plans shall be bound in the same manner as they were let, not combined. In other words, if a project includes road and bridge work and each is bound separately, keep them separate for As-Built, each with its own AB201 cover sheet.

In submitting As-Built Plans, the Contractor shall be required to complete FORM AB205 or AB206 whichever is applicable, and submit the form with the required deliverables to the RCE. The items and notes on these forms that apply to this project establish the minimum requirements for As-Built Plans. The forms can be found on the SCDOT website at <http://www.scdot.org/doing/default.html>.

The final As-Built plans shall be submitted within forty-five (45) days following the substantial work complete date of the project.

MEASUREMENT

Measurement is to be on a lump sum basis.

PAYMENT

Payment for this item is to be as follows:

50% of the contract amount is to be distributed over the duration of the project, and paid in amount proportional to the amount of contract work completed.

The remaining 50% of the contract amount is to be paid on the final estimate if As-Built plans meet the requirements to the satisfaction of the Resident Engineer.

In no case is payment to be in excess of the original bid amount for this item.

The Bid Item for this work is as follows:

<u>Item Number</u>	<u>Item</u>	<u>Unit</u>
1090200	As-Built Construction Plans	LS

TRANSPORTATION AND DELIVERY OF MIXES

Subsection 401.4.17, Transportation and Delivery of Mixes, of the Standard Specification will be deleted in its entirety and replaced with the following:

Transport the HMA from the plant to the point of use in vehicles meeting the requirements of Subsection 401.3.7. Do not permit any load of HMA to leave the plant so late in the day that it cannot be spread, finished, and compacted during daylight of that same day unless an approved artificial lighting system is provided. Ensure that HMA mixtures containing the asphalt binder grades below are produced and delivered to the jobsite within the acceptance range listed in the table below with exception that Base C and D mixtures will be produced and delivered at a temperature range of 240°-275° F. The mix temperatures will be checked using SC-T-84. Ensure the HMA mixtures are held within the acceptance range based on Binder Performance Grade in the Job Mix Formula. Deliver mixture within the acceptance range for temperature to assist in obtaining density requirements which provide smooth riding pavements with uniform texture.

Binder Performance Grade	Acceptance Range (°F)
PG 64-22	265°-325°
PG 70-22	285°-335°
PG 76-22	300°-350°

Note: This temperature specification does not apply to WMA (SC-M-408). Refer to the HMA Contractor's QC Plan for mix acceptance range based on selected asphalt plant WMA technologies.

July 2, 2009

**HIGH PRESSURE WATER METHOD
For
REMOVAL OF PAVEMENT MARKINGS**

1. Description. -

This item consists of removal of pavement markings from an asphalt or concrete pavement course by utilization of high pressure water. Eradicate and remove existing and temporary pavement markings, including waterborne fast dry paint, thermoplastic, and epoxy pavement markings, from the pavement surface by high pressure water where directed by the plans, the special provisions, the standard specifications, the MUTCD, and the Engineer.

2. Requirements. -

The Contractor shall conduct the removal operations of the pavement markings without damaging the surface or texture of the pavement course.

The Contractor shall remove no less than 95 percent of the total area of the pavement markings designated for removal to provide uniform exposure of the pavement surface. The presence of remnant pavement markings that indicate or may be perceived as a line shall require the Contractor to repeat the removal process.

The area of removal shall extend beyond all edges of the pavement marking designated for removal no less than ½ inch.

The Contractor shall remove all recoverable residue from the water blast cleaning method, including the water. When operating within 10 feet of a travel lane open to traffic or in an area that the residue may encroach onto the adjacent travel lane, the Contractor shall remove the residue immediately after contact between the water and the pavement surface. The removal process shall require a vacuum attachment operating concurrently with the blast operation or by an alternate method as approved by the Engineer. The Contractor is responsible for maintaining safety as required by the Department and all federal, state, and local laws.

In areas where pavement joints are present, the Contractor shall provide adequate protection of the pavement joints to prevent damage, disfigurement, compaction, or recession of the pavement joint material. The Contractor shall obtain approval of the proposed methods for providing protection of the joint material from the Engineer prior to beginning the work.

Removal of pavement markings by high pressure water is prohibited when the ambient air temperature is 40 degrees Fahrenheit or less or anticipated to decrease to 40 degrees Fahrenheit or less within 2 hours.

3. Method of Measurement. -

The Department will pay for removal of the pavement markings designated for removal by high pressure water at the contract unit price bid.

Measure the pavement markings designated for removal in square feet of the actual pavement markings to be removed. Determine the length of the pavement marking by measuring along the center of the line by the linear foot, excluding the spaces between broken lines, and multiplying by the width of the pavement marking in place. The measurement shall include the area of the marking only and shall exclude the area that extends ½" beyond the edges of each pavement marking designated for removal. The area ½" beyond the edges of each pavement marking shall be considered incidental.

Measure the removal of arrows, words, and railroad crossing symbols by the square footage of the full area occupied by the arrow, word, or railroad crossing symbol. To determine the square footage of arrows and words, measure the area as a complete square or rectangular area to encompass the complete arrow or word. The edges of the square or rectangular area designated for removal shall be parallel and perpendicular to the adjacent edge of pavement. A railroad crossing symbol consists of an "X" and two "R" 's. Determine the area of the railroad crossing symbol for removal, including only the area occupied by the "X" and two "R" 's, as a complete square or rectangle as designated above.

The Department will make no separate measurement for payment for traffic control during removal of pavement markings. Include all costs for traffic control in the contract lump sum price bid item for "Traffic Control". In the absence of a bid item for "Traffic Control", consider traffic control for application and removal of pavement markings incidental to the pavement marking bid items.

4. Basis of Payment.

The Department shall provide full compensation for providing all materials necessary to complete the job properly. Payment shall include the removal of the pavement markings, furnishing the materials, all labor, hardware, equipment, tools, incidentals, and any miscellaneous items necessary to complete the item of work.

Payment for each item includes all direct and indirect costs and expenses required to complete the work.

Payment will be made under:

ITEM NO.	PAY ITEM	PAY UNIT
6091405	REMOVAL OF PAVEMENT MARKINGS (HIGH PRESSURE WATER)	SF

**TRAILER MOUNTED
AUTOMATED FLAGGER ASSISTANCE DEVICE SYSTEM
(AFAD)**

1. Description:

This specification details the minimum requirements of all Automated Flagger Assistance Device Systems (AFAD) utilized and placed into operation on the roadways of the state of South Carolina.

An automated flagger assistance device system is a temporary traffic control device system for controlling the flow of traffic through temporary traffic control areas, typically work zones, that generate the requirement for two-way traffic to share a single travel lane. An automated flagger assistance device system shall consist of no less than 2 individual AFAD units linked and remotely controlled by wireless communications. A flagger(s), who has successfully completed a flagger training course sponsored by a South Carolina Department of Transportation approved work zone traffic control training provider, shall operate the system. Install, operate and maintain each AFAD unit as designated by these Supplemental Specifications, the manufacturer's specifications, the Standard Drawings for Road Construction, the Plans and the Engineer.

An automated flagger assistance device system acceptable for use on the roadways of the state of South Carolina shall be either a Type I "RED / YELLOW" Lens system or a Type II "STOP / SLOW" Sign system.

The automated flagger assistance device system shall comply with all requirements for Automated Flagger Assistance Devices as specified and directed by the MUTCD, latest edition, and this supplemental specification. An automated flagger assistance device system shall operate and comply with all requirements for flagging operations as specified and directed by the latest editions of the MUTCD, the South Carolina Flagger's Handbook and the Standard Specifications for Highway Construction. Also, an automated flagger assistance device system shall operate and comply with all requirements for flagging operations as specified and directed by the Standard Drawings for Road Construction, the special provisions, the plans and the Engineer.

2. Operations Requirements:

A. General: Automated flagger assistance device systems are only permitted for use on two-lane two-way roadways where each single travel lane of opposing traffic is required to utilize and share one travel lane. An AFAD system is PROHIBITED for use on multilane roadways with reduced numbers of travel lanes. An AFAD is not a traffic control signal and shall not be used as a temporary traffic control signal or to control traffic at any location with more than 2 opposing single travel lanes seeking to share one travel lane.

B. Documentation: Provide documentation to the SCDOT to verify that each operator of an automated flagger assistance device system has successfully completed instruction in the operation of a system by the manufacturer of that system. Also, provide documentation to verify that each operator has successfully completed a flagger training course sponsored by a South Carolina Department of Transportation approved work zone traffic control training provider.

1. **Work Conducted under Contract to SCDOT** - Provide documentation of proof of successful completion of training in the proper operation of the AFAD system by the manufacturer of the system and successful completion of training as a flagger by a South Carolina Department of Transportation approved work zone traffic control training provider to the Resident Engineer no less than 7 days prior to placing an automated flagger assistance device into operation.

2. **Work Conducted under Encroachment Permit** - Provide documentation of proof of successful completion of training in the proper operation of the AFAD system by the manufacturer of the system and successful completion of training as a flagger by a South Carolina Department of Transportation approved work zone traffic control training provider along with submittal of the encroachment permit to the SCDOT.

C. Operator: The operator of the an automated flagger assistance device system shall be a recipient of and have successfully completed instruction in the operation of the system by the manufacturer of that system. The operator shall have successfully completed a flagger training course sponsored by a South Carolina Department of Transportation approved work zone traffic control training provider.

The South Carolina Department of Transportation only recognizes the following entities as acceptable providers of work zone traffic control training for organizations outside of the SCDOT who perform work activities within the highway rights-of-way in South Carolina under either contract to SCDOT or encroachment permit:

American Traffic Safety Services Association (ATSSA)
Institute for Transportation Research and Education at North Carolina State University (ITRE)
Carolinas Association of General Contractors (AGC)
National Safety Council South Carolina Chapter

The operator shall control the automated flagger assistance device system from a location with an unobstructed view of the AFAD unit as well as an unobstructed view of the approaching traffic. If a single operator is controlling more than one unit, the operator shall have an unobstructed view of traffic from both directions. At no time is the operator permitted to leave the AFAD unattended when the AFAD is operating.

D. Site Location: When sufficient shoulder space is available, place and position the AFAD unit on the shoulder of the roadway no closer than 1 foot from either the near edge line or the near edge of pavement when an edge line is absent to the near edge of the trailer when the gate arm is in the upright position. When sufficient shoulder space to attain the minimum 1 foot requirement is unavailable, minimal encroachment of the unit upon the adjacent travel lane is permitted.

Place and position the AFAD unit to allow the end of the gate arm, when in the down position, to reach the center of the adjacent travel lane being controlled by the unit. Encroachment by the gate arm when in the down position to a point less than to the center of the adjacent travel lane or into the opposing travel lane beyond the center of the roadway is PROHIBITED.

Install the advance warning signs required for typical flagging operations on each approach. In addition to the typical flagging operations sign array, also include and install a "Be Prepared To Stop" sign (W3-4-48) between the "Flagger" symbol sign (W20-7-48) and the AFAD unit on each approach. Therefore, the required advance warning signs for each approach are, "Be Prepared To Stop" (W3-4-48), "Flagger" symbol (W20-7-48), "One Lane Road Ahead" (W20-4-48-A) and "Road Work Ahead" (W20-1-48-A).

E. Nighttime AFAD Flagging Operations: During nighttime operations, illuminate each AFAD unit station with any combination of portable lights, standard electric lights, existing street lights, etc., that will provide a minimum illumination level of 108 Lx or 10 fc.

During nighttime operations, operators shall wear a safety vest and safety pants that comply with the requirements of ANSI / ISEA 107 standard performance for Class 3 risk exposure, latest revision, and a fluorescent hard hat. The safety vest and the safety pants shall be retroreflectorized and the color of the background material of the safety vest and safety pants shall be fluorescent orange-red or fluorescent yellow-green.

Supplement the array of advance warning signs with a changeable message sign for each approach during nighttime AFAD flagging operations. These changeable message signs are not required during daytime operations. Install the changeable message signs 500' in advance of the advance warning sign arrays. Messages should be "Flagger Ahead" and "Prepare To Stop".

3. System Requirements:

A. General: An automated flagger assistance device system shall consist of a Main AFAD unit and a Remote AFAD unit, linked and remotely controlled by wireless communications. The individual trailer-mounted units shall have nesting capabilities to permit towing of both units in a single trailer configuration. When nested, all lights including stop, tail and turn signal lights of both units shall operate uniformly.

B. Power Source: The electrical power for operation of the sign shall be supplied by a 12 VDC power source or a 110 VAC or a 120 VAC power source. Provide and mount a D/C power source for the unit on the trailer. An adaptable 110 VAC or 120 VAC power source may be used when available and selected for use.

1. **D/C Powered:** Power the unit by means of a battery bank charged by photovoltaic solar panels and/or a built-in 110 VAC 10 amp battery charger. House the battery bank in a lockable heavy duty weatherproof box or cabinet. The battery bank shall have the capability to provide sufficient operating power to the unit for no less than 7 continuous days.
2. **A/C Powered:** Power the unit by means of a 110 VAC or 120 VAC power source. Equip the unit with ground fault circuit interrupter circuit breakers. Conduct all A/C power adaptations with UL approved equipment and methods.

C. Remote Control: Equip each AFAD unit with a controller capable of receiving and implementing instructions through wireless communications from a handheld transceiver. Also, equip each AFAD unit with a handheld transceiver that provides wireless communication with the unit controller to permit operation of the individual unit or the system by an operator or operators from remote locations. The system shall provide the capability for total system operation and control of both units by one operator from a primary handheld transceiver as well as allow independent unit operation by one operator per unit from unit specific handheld transceivers.

Monitor and verify data transmissions utilized to control the AFAD units. Digitally encode signal transmissions to minimize interference. Comply with all applicable requirements of the Federal Communications Commission. In the event communications are disrupted or lost, the system shall go into a "fail safe" mode and display the "Circular Red" / "STOP" indications and lower the gate arms.

D. Gate Arm: Equip each AFAD unit with an automated gate arm that descends to a down position across the travel lane that approaching traffic is operating in when the AFAD unit displays the condition for approaching traffic to stop. The automated gate arm shall ascend to an upright position when the AFAD unit displays the condition to allow stopped traffic to proceed past the location of the AFAD unit.

Acceptable operation of the gate arm shall require the gate arm to begin descent to the down position no less than 2 seconds or more than 4 seconds after the AFAD unit displays the condition for approaching traffic to stop. The gate arm shall begin ascent to the upright position not less than 1 second or more than 2 seconds prior to display of the condition to allow stopped traffic to proceed.

The gate arm shall measure no less than 8 feet in length and shall have a minimum vertical height of 4 inches when placed in the down position. Reflectorize both sides of the gate arm with a Type III Microprismatic retroreflective sheeting with vertical alternating red and white stripes at 16 inch intervals.

The gate arm shall deflect in the event an errant vehicle drives through and strikes the gate arm and then return to a functional position after the errant vehicle clears the gate arm.

E. Trailer: Fabricate and equip each trailer with a single axle, springs, support assembly and four (4) leveling or stabilizer jacks. Properly equip the trailer to comply with South Carolina Law governing motor vehicles. The minimum requirement for lights and reflectors shall include turn signals, dual tail lights, and brake lights. Equip each trailer with Safety chains meeting SAE J-697 standards and paint each trailer with Federal Standard No. 595, Orange No. 12246.

Each trailer mounted AFAD unit shall have the capability to withstand winds up to 80 MPH without overturning when in the operating configuration or position.

4. Type I “RED / YELLOW” Lens System:

A Type I “RED / YELLOW” Lens AFAD system shall alternately display a steadily illuminated Circular RED lens and a flashing Circular YELLOW lens to control traffic without the need for a “human flagger” in the immediate vicinity of the AFAD unit. The steadily illuminated Circular RED lens shall illuminate when approaching traffic is required to stop and the flashing Circular YELLOW lens shall illuminate when stopped or approaching traffic is permitted to proceed pass the location of the AFAD unit.

A RED / YELLOW Lens AFAD unit shall have no less than one set of Circular RED and Circular YELLOW lenses in a vertical configuration that have diameters of no less than 12 inches. Arrange the lenses to place the Circular RED above the Circular YELLOW and provide a minimum height of no less than 7 feet from the bottom of the apparatus housing the Circular YELLOW lens to the grade elevation of the travel lane under control of the AFAD unit. However, if the lenses are located over any portion of a travel lane in which traffic is operating and may pass underneath the lenses, the minimum mounting height shall be no less than 15 feet from the bottom of the apparatus housing the YELLOW lens to the grade elevation of the travel lane under control of the AFAD unit in which traffic is operating.

The gate arm shall begin its descent to the down position not less than 2 seconds or more than 4 seconds after the Circular RED lens is illuminated. The automated gate arm shall begin its ascent to the upright position not less than 1 second or more than 2 seconds prior to illumination of the flashing Circular YELLOW lens.

Install a “Stop Here On Red” sign (R10-6-36) or (R10-6a-30) on the right side of the approach at the point at which motorists are expected to stop when the Circular RED lens is illuminated.

Transition Between RED and YELLOW Conditions -

Transition to Circular RED condition - The flashing Circular YELLOW lens shall enter into a minimum 5 second steady illumination phase prior to transitioning to the steadily illuminated Circular RED condition. The gate arm shall begin its descent not less than 2 seconds or more than 4 seconds after the Circular RED lens is illuminated.

Transition to Circular YELLOW condition - The gate arm shall complete its ascent to the upright position not less than 1 second or more than 2 seconds prior to illumination of the flashing Circular YELLOW lens. The steadily illuminated Circular RED lens shall transition to the flashing Circular YELLOW lens.

The Type I “RED / YELLOW” Lens AFAD system shall include a fail-safe system with a conflict monitor or similar device to prevent display of conflicting indications between units. Also, the system shall provide indicators to notify the operators of power loss that may impede proper operation of the system.

5. Type II “STOP / SLOW” Sign System:

A Type II “STOP / SLOW” Sign AFAD system shall have a STOP / SLOW sign that alternately displays the STOP (R1-1-36) face and the SLOW (W20-8-36) face of a STOP / SLOW paddle to control traffic without the need for a “human flagger” in the immediate vicinity of the AFAD unit. The STOP sign face shall display when approaching traffic is required to stop and the SLOW sign face shall display when stopped or approaching traffic is permitted to proceed pass the location of the AFAD unit.

The STOP / SLOW sign, fabricated from a rigid material, shall have an octagonal shape with a minimum face size of 36 inches by 36 inches. Reflectorize each face of the sign with a Type VII, Type VIII or Type IX Prismatic Retroreflective sheeting included on the latest edition of the *SCDOT Qualified Products List 20*. The STOP sign face shall have a red background with white letters and border and the SLOW sign face shall have a diamond shaped orange background with black letters and border. The letters shall have a minimum height of 8 inches. The sign faces shall have a minimum mounting height of 7 feet from the bottom of the sign to the grade elevation of the travel lane under control of the AFAD unit.

Supplement the Type II "STOP / SLOW" Sign AFAD unit with active conspicuity devices. Include a steadily illuminated RED lens beacon to illuminate when the STOP sign face is displayed and a flashing YELLOW lens beacon to illuminate when the SLOW sign face is displayed. Each beacon shall have a 12 inch signal lens. Mount the RED lens beacon no more than 24 inches above the top of the STOP sign face and YELLOW lens beacon no more than 24 inches above the top or to the side of the SLOW sign face.

Type B warning lights are PROHIBITED as alternatives to the 12 inch signal lens beacons.

The gate arm shall begin its descent to the down position 2 seconds or more than 4 seconds after the transition to a complete display of the STOP sign face is accomplished and the illumination of the steadily illuminated RED lens beacon. The automated gate arm shall begin its ascent to the upright position not less than 1 second or more than 2 seconds prior to the initiation of the transition from the STOP sign face to the SLOW sign face.

Install a "Wait On Stop" sign (R1-7-30) and a "Go On Slow" sign (R1-8-30) either on the same support structure as the AFAD unit or immediately adjacent to the AFAD unit.

Transition Between STOP and SLOW Conditions -

Transition to STOP condition - The RED lens beacon shall enter into a "flashing mode" no less than 5 seconds prior to transitioning from the SLOW sign face to the STOP sign face. Immediately upon completion of the transition to complete display of the STOP sign face, the "flashing mode" of the RED lens beacon shall transition to a steadily illuminated condition. The gate arm shall begin its descent in not less than 2 seconds or more than 4 seconds after completion of the transition to a complete display of the STOP sign face and illumination of the steadily illuminated RED lens beacon.

Transition to SLOW condition - The STOP sign face shall begin the transition to the SLOW sign face. The gate arm shall begin its ascent to the upright position not less than 1 second prior to the initiation of the transition from the STOP sign face to the SLOW sign face. The RED lens beacon shall cease to illuminate and the flashing YELLOW lens beacon shall begin to illuminate immediately upon completion of the transition of the STOP sign face to the SLOW sign face and the ascent of the gate arm to its completed upright position.

The Type II "STOP / SLOW" Sign AFAD system shall include a fail-safe system with a conflict monitor or similar device to prevent display of conflicting indications between units. Also, the system shall provide indicators to notify the operators of power loss that may impede proper operation of the system.

3. Method of Measurement: Unless otherwise specified, Automated Flagger Assistance Device Systems (AFAD's) are not measured for separate payment but are included in the contract lump sum bid price item Traffic Control as specified in Subsections 107.12 and 601.5 of the *2007 Standard Specifications for Highway Construction*.

4. Basis of Payment: Unless otherwise specified, payment for an Automated Flagger Assistance Device System (AFAD) is included in the contract lump sum bid price item Traffic Control as specified in Subsections 107.12 and 601.5 of the *2007 Standard Specifications for Highway Construction*. The payment shall be full compensation for providing, installing, removing, and relocating as necessary, operating, and maintaining an Automated Flagger Assistance Device System (AFAD). Payment shall include furnishing all labor, hardware, equipment, tools, incidentals, and any miscellaneous items necessary for installing, operating, and maintaining the system.

DISTRICT SIX LANE CLOSURE RESTRICTIONS

Roads on the following lists are restricted from daytime lane reductions or closures. All work requiring lane reductions or closures will be performed at night or possibly on weekends. Specific work hours will be determined on a case-by-case basis. Unscheduled or emergency repairs requiring lane reductions or closures may be allowed at other times upon approval by the RCE. Questions concerning this requirement are to be directed to the District Traffic Engineer.

COUNTY	ROAD NO.	ROAD NAME	FROM	TO
Beaufort	US 17	N/A	Colleton County Line	US 21
Beaufort	US 21	N/A	SC 116	End
Beaufort	US 21 Business	N/A	US 21	US 21
Beaufort	US 278	N/A	Jasper County Line	End
Beaufort	US 278 Business	William Hilton Pkwy	US 278	S-80
Beaufort	SC 46	N/A	Jasper County Line	US 278
Beaufort	SC 170	N/A	Jasper County Line	US 21
Beaufort	SC 280	N/A	US 21	SC 802
Beaufort	SC 802	N/A	SC 170	S-673
Beaufort	S 29	Buck Island Road	S-474	US 278
Beaufort	S 80	Palmetto Bay Rd.	US 278	End
Beaufort	S-163	Burnt Church Rd.	S-13	End
Beaufort	S-474	Simmons ville Rd.	US 278	S-29

COUNTY	ROAD NO.	ROAD NAME	FROM	TO
Berkeley	Interstate 26	N/A	Dorchester County Line	Charleston
Berkeley	Interstate 526	N/A	Charleston County Line	Berkeley County
Berkeley	US 17A	N/A	Dorchester County Line	US 52
Berkeley	US 52	N/A	Charleston County Line	S-791
Berkeley	US 52 Bypass	S-1094	US 17A	SC 402
Berkeley	US 176	N/A	US 17A	US 52
Berkeley	SC 41	N/A	Charleston County Line	S-33
Berkeley	S-16	Jedburg Rd.	Dorchester County Line	US 176
Berkeley	S-24	Yeamans Hall Rd.	S-10-13 (Remount Rd)	S-136
Berkeley	S-29	Redbank Rd.	S-136	Naval Weapons
Berkeley	S-33	Clements Ferry Rd.	SC 41	End
Berkeley	S-62	College Park Rd.	US 78	US 17A
Berkeley	S-88	Murray Ave.	S-10-13 (Remount Rd)	S-89
Berkeley	S-89	N/A	S-88	Charleston
Berkeley	S-98	Cainhoy Rd.	SC 41	S-33
Berkeley	S-136	N. Rhett	Goose Creek Reservoir	Charleston
Berkeley	S-1093	Crowfield Blvd.	US 176	S-62

COUNTY	ROAD NO.	ROAD NAME	FROM	TO
Charleston	I 26	N/A	Berkeley County Line	End
Charleston	I 526	N/A	US 17	US 17
Charleston	I 526 Spur	Chuck Dawley Blvd.	I 526	SC 703 - Jasper
Charleston	US 17	N/A	Lieben Rd S-1814	SC 162
Charleston	US 52	Rivers Ave.	Berkeley County Line	S-1042
Charleston	US 52 Connector	N/A	US 52	I 26
Charleston	US 52 Spur	N/A	US 52 (Meeting St.)	S-1015
Charleston	US 78	N/A	Dorchester County Line	US 17
Charleston	SC 7	Sam Rittenberg	US 17	US 52/78
Charleston	SC 30	James Island Expwy	SC 171	US 17
Charleston	SC 41	N/A	Berkeley County Line	US 17
Charleston	SC 61	Ashley River Rd.	Dorchester County Line	US 17
Charleston	SC 61 Express	Glenn McConnel	SC 61	Bees Ferry Rd
Charleston	SC 162	N/A	US 17	SC 174
Charleston	SC 171	Folly Rd.	SC 7	S-94
Charleston	SC 517	IOP Connector	US 17	SC 703
Charleston	SC 642	Dorchester Rd.	Dorchester County Line	US 52
Charleston	SC 700	Maybank Hwy.	Church Creek	SC 171
Charleston	SC 703	N/A	US 17	SC 703 - Jasper
Charleston	S-13	Remount Rd.	US 52	S-24
Charleston	S-20	Main Rd.	Bee's Ferry Rd S-57	S-633
Charleston	S-28	Camp Rd.	SC 171	S-53
Charleston	S-51	Rifle Range Rd	SC 703	US 17
Charleston	S-53	Riverland Dr	SC 700	S-28
Charleston	S-56	Mathis Ferry Rd	US 17	US 17
Charleston	S-57	Bee's Ferry Rd.	SC 61	US 17
Charleston	S-60	N. Rhett	Berkeley County Line	Park Circle
Charleston	S-75	Ashley Phospate	Dorchester County Line	US 52
Charleston	S-76	Ladson Rd.	Dorchester County Line	Berkeley County
Charleston	S-94	Fort Johnson Rd	SC 171	S-1028
Charleston	S-97	Long Point Rd.	US 17	End
Charleston	S-107	Meeting St.	US 52	S-1015
Charleston	S-280	Stall Rd.	S-75	S-1187
Charleston	S-404	Calhoun St.	SC 30	US 52 Spur
Charleston	S-404/658/1194	Lockwood Dr.	S-1015	S-658
Charleston	S-405	Hanahan Rd.	US 52	Berkeley County
Charleston	S-1028	Harbor View Rd.	SC 30	S-94
Charleston	S-1168	Savage Rd.	US 17	SC 61
Charleston	S-1271	Bowman Rd.	S-56	Chuck Dawley
Charleston	S-2028	Cross County Rd.	S-75	SC 642

COUNTY	ROAD NO.	ROAD NAME	FROM	TO
Colleton	I 95	N/A	Hampton County Line	Dorchester
Colleton	US 15	N/A	US 17A	SC 64
Colleton	US 17	N/A	Beaufort County Line	Charleston
Colleton	US 17A	N/A	SC 63	Dorchester

COUNTY	ROAD NO.	ROAD NAME	FROM	TO
Dorchester	I 95	N/A	Colleton County Line	Orangburg
Dorchester	I 26	N/A	Orangburg County Line	Berkeley County
Dorchester	US 17A	N/A	Colleton County Line	Berkeley County
Dorchester	US 78	N/A	S-58	Charleston
Dorchester	SC 165	Bacons Bridge	SC 61	S-199
Dorchester	SC 165	Berlin G. Myers Pky	S-199	Berkeley County
Dorchester	SC 642	Dorchester Rd.	S-22	Charleston
Dorchester	S-13	Central Ave	US 78	S-22
Dorchester	S-22	Old Orangeburd Rd.	SC 642	US 78
Dorchester	S-58	Jedburg Rd.	US 78	Berkeley County
Dorchester	S-62	Ashley Phosphate Rd.	SC 642	Charleston
Dorchester	S-65	Richardson Ave.	US 78	S-65
Dorchester	S-199	Trolley Rd	SC 165	SC 642
Dorchester	S-230	Ladson Rd	SC 642	Charleston
Dorchester	S-339	Gahagan Rd.	US 17A	S-377
Dorchester	S-377	Miles Jamison Rd.	S-199	S-230

COUNTY	ROAD NO.	ROAD NAME	FROM	TO
Jasper	I 95	N/A	Georgia line	Hampton County
Jasper	US 17	N/A	Georgia line	SC 170
Jasper	SC 46	N/A	SC 170	Beaufort County
Jasper	SC 170	N/A	US 17	SC 46
Jasper	SC 170A	N/A	US 17	SC 170
Jasper	SC 336	N/A	I 95	SC 462

ADHESIVELY BONDED ANCHORS AND DOWELS

1.0 Adhesively Bonded Anchors and Dowels

1.1 Scope

Furnish all required labor, equipment, and materials and perform all operations necessary for installing anchors and dowels in concrete using an adhesive bonding system in accordance with the details shown on the Plans and with the requirements of this Specification. Provide a material system specifically intended for use in structural applications for bonding anchors and dowels to hardened concrete. Limit applications to anchors and dowels installed in horizontal, vertical, and downwardly inclined positions. Do not use adhesive anchors in overhead or upwardly inclined installations. See Figure 1.1.

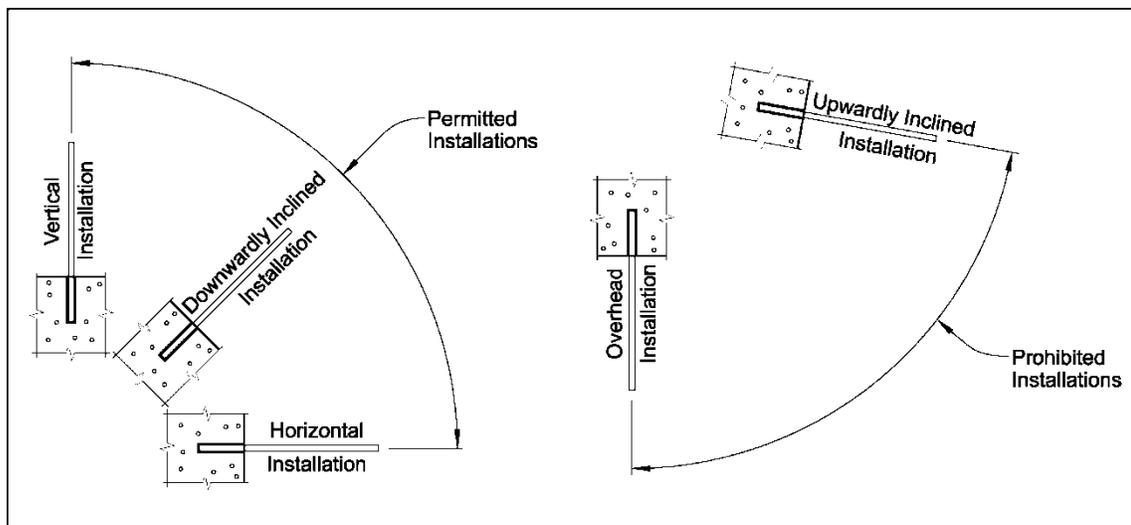

Figure 1.1

Submit a description of the proposed adhesive bonding system to the RCE for review, comments, and acceptance. Include in the description the anchor type, equipment, Manufacturer's recommended hole diameter, material specifications, and any other material, equipment or procedure not covered by the contract documents. List the properties of the adhesive, including density, minimum and maximum temperature application, setting time, shelf life, pot life, shear strength, bond strength, and compressive strength. If anchors or dowels containing a corrosion protective coating are required, provide an adhesive that does not contain any chemical elements that are detrimental to the coating and include a statement to this effect in the submittal concerning the contents as required by State or Federal Laws and Regulations.

Submit to the RCE Manufacturer's certification that the adhesive bonding system, when tested for tension pull-out according to ASTM E 488 utilizing identical anchorages, embedment depths, and concrete strengths as those specified on the Plans, does not fail by any mode listed in Section 12 of ASTM E 488 when loaded to the lesser of 85 percent of the specified bond strength (based on the nominal anchorage diameter and embedment depth) or 90 percent of the yield strength of the anchor. Also, submit to the RCE long term load (creep) test results performed in accordance with ASTM E 1512, ICC-ES AC 58, or ICC-ES AC 308. When specified on the Plans, field testing will also be required for adhesive anchorages.

1.2 Materials

Provide adhesive bonding material systems for structural applications that meet the requirements of ASTM C 881, Type IV, Grade 3, Class B or C (depending on site conditions). Do not use "Fast Set epoxy." Package components of the adhesive in containers of such size that one whole container of each component is used in mixing one batch of adhesive. Use containers of such design that all of the contents may be readily removed, and are well sealed to prevent leakage. Do not use material from containers which are damaged or have been previously opened. Use only full packages of components. Furnish adhesive material that requires hand mixing in two separate containers designated as Component A and Component B or in a self contained cartridge or capsule that consists of two components which will be automatically mixed as they are dispensed, as in the case of a cartridge, or drilled into, as in the case of a capsule.

Provide packages clearly marked by the Manufacturer with the following information:

- Manufacturer's name and address
- Product Name
- Date of Manufacture
- Expiration Date
- LOT Identification Number
- Storage and Handling Requirements

With each package include the Manufacturer's instructions for anchor and dowel installation. Include the following information with the instructions:

- Diameters of drilled holes for applicable anchor and dowel sizes.
- Cleaning procedure for drilled holes, including a description of permitted and prohibited equipment and techniques.
- Allowable temperature ranges for storage, installation and curing.
- Identification of acceptable mixing/dispensing nozzles.
- Fabrication requirements for anchors and dowels.
- Description of tools permitted or required for installation.
- Method of identifying properly proportioned and mixed adhesive materials.
- Time and temperature schedule for initial set ('gel time') and full-strength cure.
- Requirements for special installation conditions such as horizontal or near horizontal orientation of the anchor or dowel.

1.3 Construction Requirements

1.3.1 Storage

Deliver the adhesive bonding material system to the job-site in original unopened containers with the Manufacturer's label identifying the product. Store materials delivered to the job-site in the original unopened containers within an appropriate facility capable of maintaining storage conditions consistent with the Manufacturer's recommendations.

1.3.2 Installation

Install the adhesive anchors and dowels perpendicular to the plane surface of the structural member, in accordance with Manufacturer's recommendations, and when the concrete is above 40 degrees Fahrenheit and has reached its 28 day strength. Install the anchorages before the adhesive's initial set ('gel time').

1.3.2.1 Drilling of Holes into Concrete

Ensure that concrete members receiving adhesive-bonded anchors or dowels are structurally sound and free of cracks in the vicinity of the anchor or dowel to be installed. When directed by

the RCE, use a jig or fixture to ensure the holes are positioned and aligned correctly during the drilling process.

Use a metal detector specifically designed for locating steel in concrete to avoid conflicts with existing steel reinforcement whenever placement tolerances and edge clearances permit. Unless other equipment is recommended by the Manufacturer, drill holes to the diameter required by the Manufacturer using a rotary hammer drill and bit. Perform core drilling to clear existing steel reinforcement only when approved by the RCE. Dry the drilled holes completely prior to cleaning and installing the anchors or dowels. Clean and prepare drilled holes in accordance with the Manufacturer's recommendations, but as a minimum, use oil-free compressed air to remove loose particles from drilling, brush inside surface to free loose particles trapped in pores, then use compressed air again to remove the remaining loose particles. Use a non-metallic bristle brush and avoid over-brushing to prevent polishing the inside surface of the drilled hole. Check each hole with a depth gauge to ensure proper embedment depth. Repair spalled or otherwise damaged concrete using methods approved by the RCE.

1.3.2.2 Inspection of Holes

Inspect each hole immediately prior to placing the adhesive and the anchors/dowels. Ensure all holes are dry and free of dust, dirt, oil, and grease.

1.3.2.3 Mixing of Adhesive

Mix the adhesive in strict conformance with the Manufacturer's instructions.

1.3.2.4 Embedment of Anchors and Dowels

Remove all debris, oils, and any other deleterious material from the anchors and dowels to avoid contamination of the adhesive bonding material. Insert the anchor or dowel the specified depth into the hole and slightly agitate it to ensure wetting and complete encapsulation. After insertion of the anchor or dowel, strike off any excessive adhesive flush with the concrete face. Should the adhesive fail to fill the hole, add additional adhesive to the hole to allow a flush strike-off. Do not disturb the anchors and dowels while adhesive is hardening. For horizontal and inclined installations, provide temporary supports to maintain the alignment of the anchors or dowels until the adhesive bonding material has cured.

1.3.3 Field Testing

When specified on the Plans, field test the installed anchors and dowels. Perform field testing of the installed anchors and dowels in accordance with the applicable sections of ASTM E 488. Inform the RCE and the Manufacturer when the tests will be performed at least 2 days prior to testing. For testing, use a calibrated hydraulic centerhole jack system that will not damage the anchor or dowel. Place the jack on a plate washer that has a hole at least 1/4" larger than the hole drilled into the concrete. Position the plate washer on center to allow an unobstructed pull. Position the anchors/dowels and the jack on the same axis. Have an approved testing agency calibrate the jack within 6 months prior to testing. Supply the RCE with a certificate of calibration.

Divide the anchors and dowels into LOTs for field testing and acceptance. A LOT consists of anchors or dowels of the same type, diameter, strength, embedment length, and adhesive bonding system. Prior to performing field tests, submit proposed testing locations to the RCE for review, comments, and acceptance. In the presence of the RCE, field test the anchors or dowels for each LOT in accordance with the following:

Test a minimum of 1 anchorage but not less than 10% of all anchors in the LOT to the test load shown on the Plans.

If less than 60 anchorages are to be installed: Install and test the minimum required number of anchorages prior to installing the remaining anchorages. After installing the remaining anchorages, test a minimum of 2 of these anchorages at random locations selected by the RCE.

If more than 60 anchorages are to be installed: Test the first 6 anchorages prior to installing the remaining anchorages. Then test, at random locations selected by the RCE, 10% of the number in excess of 60 anchorages.

For every failed field test, perform two additional field tests on adjacent untested anchors or dowels within the LOT. Continue additional field tests until no more test failures occur, or until all anchors and dowels within the LOT are tested.

Begin testing after the Manufacturer's recommended cure time has been reached. For testing, apply and hold the test load for three minutes. If the jack experiences any drop in gage reading, restart the test. For the anchorage to be deemed satisfactory, hold the test load for three minutes with no movement or drop in gage reading.

Remove all anchors and dowels that fail the field test, without damage to the surrounding concrete. Re-drill holes to remove adhesive bonding material residue and clean the hole in accordance with Subsection 1.3.2.1. For reinstalling replacement anchors or dowels, follow the same procedures as new installations. Do not reuse failed anchors or dowels unless approved by the RCE.

Determine failure of the field test in accordance with ASTM E 488. Submit certified test reports to the RCE. Final acceptance of the adhesively anchored system is based on the conformance of the pull test to the requirements of this Specification. Failure to meet the criteria of this Specification is grounds for rejection.

1.4 Measurement

No separate measurement for payment will be made for furnishing, installing, and testing of adhesively bonded anchors and dowels.

1.5 Payment

Include all costs of adhesively bonded anchors and dowels in the contract unit price bid for the items to be anchored.

CONCRETE BATCHING AND MIXING

Delete subsection 701.4.4.1 Concrete Batching and Mixing – General, of the Standard Specifications in its entirety and replace it with the following:

701.4.4 Concrete Batching and Mixing

701.4.4.1 General

- 1 When concrete is furnished by a transit or central-mix plant, use batching equipment that is sufficient to weigh a load of the required size in less than 15 minutes.
- 2 Make certain that an SCDOT-certified concrete field technician is present at the plant when concrete is being produced for SCDOT work. The SCDOT-certified concrete field technician may be an employee of the Contractor, the concrete supplier, or an independent testing laboratory. While concrete is being produced for SCDOT work, ensure that the SCDOT-certified concrete field technician's sole, full-time responsibility is to maintain quality control records and conduct physical testing of concrete and its constituent materials.
- 3 Ensure that an SCDOT-certified concrete field technician completes and signs *Form 700.04* for the first load of each class of concrete delivered to the job site each day. After the completion of *Form 700.04* for the first delivered load, subsequent loads of each class of concrete will require *Form 700.04* or an OMR pre-approved batch ticket containing the appropriate information. A batch ticket may be pre-approved for use in SCDOT work through the Structural Materials Engineer if the batch ticket format contains at a minimum: date and time batched, load size, ticket number, aggregate moistures, amount of free water in aggregates, design target weights or measures for all materials, actual batch weights or measures for all materials, batched variances from targets listed as a percentage for all materials, designed water/cementitious materials ratio, batched water/cementitious materials ratios, designed batch water in gallons, actual batch water in gallons, and water in gallons held back from target value at the plant that can be added at the job site.
- 4 Except for Class 2500 concrete, prestressed concrete, and precast concrete, the Department will not accept concrete unless a completed *Form 700.04* or preapproved batch ticket that is signed and certified by the SCDOT-certified concrete technician, accompanies the delivery of the concrete. If a pre-approved batch ticket is being used and conditions warrant that the use of a batch ticket is unacceptable to the RCE, the SCDOT-certified concrete technician will discontinue using the batch ticket for acceptance and return to the use of *Form 700.04* until such time that the deficiencies of the batch ticket have been resolved and accepted by the RCE.
- 5 Provide sufficient advance notification to the [RCE](#) as to the name of the plant supplying the concrete in order to permit time to make the necessary arrangements for inspection of equipment at the plant.

April 1, 2013

**Concrete Structures –
Preformed Joint Filler**

Delete Subsection 702.2.2.1 of the Standard Specifications in its entirety and replace it with the following:

702.2.2.1 Preformed Joint Filler

Use preformed joint material that meets AASHTO M 153 or AASHTO M 213 with the following exceptions:

1. Use only materials manufactured from rubber.
2. Use materials that require a load of not less than 340 kPa or greater than 5200 kPa to compress to 50% of its thickness when tested in accordance with AASHTO T 42.
3. Use materials that have a recovery of at least 70% when tested in accordance with AASHTO T 42.

Use preformed joint material that is listed on QPL 81.

Provide a manufacturer's certification that states that the material conforms to SCDOT specifications.

April 1, 2004.

GEOTEXTILE FOR DRAINAGE FILTRATION

I. ACCEPTANCE: The Contractor shall supply to the Resident Engineer, prior to placing the material, certified test results from a recognized laboratory of those tests specified herein. Acceptance will be based on the test results meeting these requirements¹ and the material meeting all stated specifications. The Resident Engineer shall submit the certified test results to the Research and Material Engineer for acceptance. Test data shall be no more than 1 year old at the time it is furnished to the Department. Once a fabric has been accepted, it will be listed on an Approval Sheet, and only those materials listed will be acceptable. Test data must be resubmitted for reapproval every 2 years. No fabric will be used nor will payment be made for fabric until the fabric certification is received and approved by the Research and Materials Engineer. The Department reserves the right to sample and test any of the fabrics, or other materials used in drainage filtration, at any time.

II. PIPING RESISTANCE: (soil retention - all applications)

A. Soils with 50% or less particles by weight passing U.S. No. 200 sieve:

$$EOS \text{ No. (fabric)} \geq 30 \text{ U.S. Std. Sieve No.}$$

B. Soils with more than 50% particles by weight passing U.S. No. 200 sieve:

$$EOS \text{ No. (fabric)} \geq 50 \text{ U.S. Std. Sieve No.}$$

Note:

- a. Whenever possible, fabric with the lowest possible EOS No. should be specified.
- b. When the protected soil contains particles from 1 inch size to those passing the U.S. No. 200 sieve, use only the gradation of soil passing the U.S. No. 4 sieve in selecting the fabric.

III. PERMEABILITY:

<u>Critical/Severe Applications *</u>	<u>Normal Applications</u>
$k (\text{fabric}) \geq 10 k (\text{soil})^2$	$k (\text{Fabric}) \geq k (\text{soil})^2$

* Woven monofilament fabrics only; percent open area ≥ 4.0 and EOS No. ≤ 100 sieve.

IV. CHEMICAL COMPOSITION REQUIREMENTS/CONSIDERATIONS:

- A. Fibers used in the manufacture of civil engineering fabrics shall consist of long chain synthetic polymers, composed of at least 85% by weight of polyolefins, polyesters, or polyamides. These fabrics shall resist deterioration from ultraviolet exposure.
- B. The engineering fabric shall be exposed to ultraviolet radiation (sunlight) for no more than 30 days total in the period of time following manufacture until the fabric is covered with soil, rock, concrete, etc.

V. PHYSICAL PROPERTY REQUIREMENTS (all fabrics)

	Class 1 Fabric ³ Protected	Class 2 Fabric ³ Unprotected
Grab Strength (ASTM D-4632 or ASTM D-1682)	80 lbs.	180 lbs.
Seam Strength ⁴ (ASTM D-4632 or ASTM D-1682)	70 lbs.	160 lbs.
Puncture Strength (ASTM D-3787)	25 lbs.	80 lbs.
Burst Strength (ASTM D-3786)	130 psi.	290 psi.
Trapezoid Tear (ASTM D-4533)	25 lbs.	50 lbs.
Ultraviolet Degradation at 150 hours (ASTM D-4355)	70%	70%

¹ All numerical values represent minimum average roll values (i.e., any roll in a lot should meet or exceed the minimum values in the table). Use values for the weaker principal direction. Lots should be sampled according to ASTM D-4354.

² Permeability should be based on the actual fabric open area available for flow. For example, if 50% of the fabric area is to be covered by flat concrete blocks, the effective flow area is reduced by 50%.

³ Fabric is said to be protected when used in drainage trenches or beneath/behind concrete (Portland or asphalt cement) slabs. All other conditions are said to be unprotected,

Examples of each condition are:

Protected: highway edge drains, blanket drains, smooth stable trenches < 10 feet in depth. In trenches, in which the aggregate is extra sharp, additional puncture resistance may be necessary.

Unprotected: stabilization trenches, interceptor drains on cut slopes, rocky or caving trenches or smooth stable trenches > 10 feet in depth.

⁴ Values apply to both field and manufactured seams.

January 1, 2009

EROSION CONTROL MEASURES

In addition to the erosion control measures specified in the Plans, Standard Specifications, Supplemental Technical Specifications and the Special Provisions, the Contractor is advised that all land disturbing activities (clearing and grubbing, excavation, borrow and fill) are subject to the requirements set forth in the following permits and regulations:

- South Carolina Code of Regulations 63-380, Standard Plan for Erosion, Sediment, and Stormwater Runoff Control.
- Erosion and Sediment Reduction Act of 1983 (Title 48, Chapter 18 of the South Carolina Code of Laws of 1983, as amended). Section 70 of this code authorized the South Carolina Department of Health and Environmental Control (SCDHEC) to administer this regulation with respect to lands under the jurisdiction of the South Carolina Department of Transportation.
- National Pollutant Discharge Elimination System (NPDES) General Permit Number SCR160000, effective January 1, 2013: The Environmental Protection Agency, in accordance with the Federal Clean Water Act, has granted to the South Carolina Department of Health and Environmental Control (SCDHEC) the authority to administer the Federal NPDES permit program in the State of South Carolina.

In accordance with the NPDES General Permit, the Contractor must sign a Contractor Certification. The certification is incorporated into the proposal form for the Contract. By signing this form, the Contractor acknowledges that upon award and execution of the Contract, he/she accepts/ understands the terms and conditions of the *Storm Water Pollution Prevention Plan (SWPPP)* as required by the NPDES General Permit and may be legally accountable to SCDHEC for compliance with the terms and conditions of the *SWPPP*. In addition, the Contractor certifies that the NPDES certification statement status is made part of all its subcontracts.

The Contractor will complete and forward an updated SCDOT approved *Notice of Intent (NOI)* to the SCDOT Construction office to submit to SCDHEC. If the Coastal Zone Consistency (CZC) permit has not been approved it shall be forwarded by the Contractor to SCDOT to submit to SCDHEC as part of *NOI* package. If SCDHEC does not send a letter within 10 business days of receipt of the *NOI*, authorizing coverage, denying coverage, or advising that a review of the *CECP* will take place, coverage will be automatically granted.

Prepare and submit a *Contractor's Erosion Control Plan (CECP)* to the RCE before the pre-construction conference. Ensure that the plan meets the requirements of the NPDES General Permit. The plan will be reviewed and approved by the Department before commencing any land disturbing activities.

At the pre-construction conference, with contactors performing land-disturbing activities present, the *CECP* will be explained and discussed so that the Contractor is made aware of their responsibilities in the *CECP*.

Once approved, fully implement the *CECP*. Coordinate the prompt installation of erosion control devices with construction activities to maintain compliance with the above regulations and NPDES General Permit.

Conduct an Erosion and Sediment Control Inspection by an appointed Certified Erosion Prevention and Sediment Control Inspector (CEPSCI) from the Contractor and the Department at least every 7-calendar days. Both parties will acknowledge participation in the inspection by signing the inspection report and include their inspector's CEPSCI number on the report. Correct deficiencies noted during these inspections within the assigned priority period. If deficiencies are not corrected within this timeframe, the RCE will stop all work (except erosion and sediment control measures) until the deficiencies are corrected.

Give special attention to critical areas within the project limits (i.e., running streams, water bodies, wetlands, etc.). In these areas, the RCE may direct the Contractor to undertake immediate corrective action, but in no case allow these deficiencies to remain unresolved more than 7 days or 48 hours in accordance with their assigned priority after being identified during the Erosion and Sediment Control Inspection.

Closely follow the grading operations with the seeding operations. Shape and prepare the slopes for seeding as the grading progresses. Unless the RCE grants prior written approval, limit the amount of surface area exposed by land disturbing activities to 750,000 square feet. Commence seeding operations within 7 days following completion of construction activities within an area.

Initiate stabilization measures within 7 days for an area where construction activities will be temporarily or permanently ceased for 14 days or longer.

Coordinate the installation of all other permanent erosion control items with the grading and seeding operations. These items include, but are not limited to, asphalt gutter and riprap. Construct gutter work before or promptly after the seeding is performed. Place riprap at the ends of pipe immediately after the pipe is laid and promptly install riprap ditch checks after ditch work has been performed.

Failure to adequately comply with the provisions as detailed above or any other required erosion control measures will result in stoppage of all contract operations (except erosion and sediment control measures) until corrective action has been taken. Additional sanctions may be invoked by the SCDHEC in accordance with their authority.

Keep the following documents at the RCE's office from the start of construction until the site is finally stabilized:

- Copy of the *CECP*,
- Copies of Contractor Certification statements,
- Copy of the permit,
- Letter from DHEC authorizing permit coverage if provided by SCDHEC, and
- A marked-up set of site plans.

When uniform perennial vegetation achieves a cover density of 70%, submit a *Notice of Termination (NOT)* to SCDHEC to terminate coverage. Include a signed statement with the *NOT* certifying that all work on the site has been completed in accordance with the *SWPPP* and the NPDES General Permit for all sites one acre or greater.

Fines assessed on the Department by SCDHEC as the result of the Contractor's non-compliance or violation of said permit provisions will be paid by the Department and will subsequently be deducted from any monies due or that may become due to the Contractor. In case no monies are due or available, the fines incurred will be charged against the Contractor's Surety.

January 2, 2013

Grout for Post-Tensioning and Prestressed Cored Slabs

Delete Subsection 704.2.6 and 704.2.7 of the Standard Specifications in their entirety and replace them with the following:

704.2.6 Post-Tensioning Grout

Use a commercial premixed grout specifically designed for grouting steel cables, anchorages, and rods meeting ASTM C 1107 requirements and approved in writing by the SME or BCE. Ensure that the commercial premixed grout is non-shrink, non-corrosive and non-metallic. At the option of the contractor a mixture of cement, water, and sand in the proportions of 1 bag of cement to 50 pounds of sand (all passing the No. 30 sieve) to about 5½ gallons of water may be used instead of the commercial premixed grout. Ensure that the sand and cement are from sources listed on the most recent editions of *SCDOT Qualified Products List 1* and *SCDOT Qualified Products List 6*. Ensure that water meets the requirements of **Subsection 701.2.11**. Use the amount of water necessary to provide a grout of the consistency of thick paint. The sand may be omitted if desired, but take care to obtain the consistency stated above. Mix the grout in a mechanical mixer for at least 2 minutes and keep it constantly agitated.

704.2.7 Grout for Prestressed Cored Slabs

Use a non-shrink, non-corrosive, and non-metallic grout meeting ASTM C 1107 requirements and approved in writing by the SME or BCE in the shear keys, dowel holes, and all recesses in the prestressed concrete of cored slabs that reaches a compressive strength of 5000 psi in 24 hours.

February 21, 2002

SEISMIC RESTRAINERS

DESCRIPTION:

Seismic restrainer units of the type or types shown on the plans, consisting of cable assemblies (cable restrainer units) and associated materials or components, shall conform to the details shown on the plans and the requirements of these special provisions.

MATERIALS:

The associated materials or components required for each seismic restrainer unit shall be as shown on the plans or as specified in these special provisions and include the following: structural steel components, studs and nuts, bearing plates, polyvinyl chloride pipe (including expansion fitting), elastomeric pads, and incidentals.

Cables shall be $\frac{3}{4}$ " preformed, 6 x 19, wire strand core or independent wire rope core (IWRC), galvanized in conformance with the requirements in Federal Specification RR-W-410D, right regular lay, manufactured of improved plow steel with a minimum breaking strength of 45 kips. Two certified copies of mill test reports of each manufactured length of cable used shall be furnished to the Engineer.

Cable assemblies (cable restrainer units) shall consist of cables, swaged fittings, studs, nuts, washers cable yield indicators, disk springs and shall conform to the following requirements:

The swaged fitting shall be machined from hot-rolled bars of steel conforming to the requirements in AISI Designation: C1035, and shall be annealed, suitable for cold swaging. A lock pinhole to accommodate a $\frac{1}{4}$ " plated spring steel pin shall be drilled through the head of the swaged fitting to retain the stud in proper position. The manufacturer's identifying mark shall be stamped on the body of the swaged fitting.

The 1" diameter stud shall conform to the requirements in ASTM A 449 after galvanizing. Prior to galvanizing, a $\frac{3}{8}$ " slot for the locking pin shall be milled in the stud end.

Nuts shall conform to the requirements in ASTM A563.

The Contractor shall furnish cable yield indicators manufactured by the following, or others, as approved by the Engineer:

Cable Moore Inc.
P.O. Box 23036
Oakland, CA 94623-0036
Phone: (510) 272-0218
Fax: (510) 272-0829

The cable yield indicators shall be machined from hot-rolled bars of steel conforming to the requirements in AISI Designation: C 1035 and shall be annealed, suitable for cold swaging. The heat number and manufacturer's identifying mark shall be stamped on the end surface of each cable yield indicator. The wall thickness of the reduced section of the cable yield indicator shall be machined by the Contractor so that the indicator yields at a load between 36 kips and 38 kips when tested in compression along the major axis at a test speed not to exceed $\frac{1}{2}$ " per minute. Two certified copies of the mill test and heat treating reports of each heat of bars used for cable yield indicators shall be furnished to the Engineer.

The disc springs shall be made from steel conforming to the requirements in ASTM A 684, Grade 1075. Galvanizing of the disc springs will not be required. The disc springs shall be cleaned and painted with a paint recommended by the manufacturer and color coded as shown on the plans.

The swaged fittings, stud and nut assembly shall develop the specified breaking strength of the cable.

The cable assemblies shall be shipped as a complete unit including cable yield indicators, disk springs, washers, stud and nut.

The Contractor shall be responsible for determining the required lengths of the cable assemblies.

The Contractor shall notify the Engineer, in writing, at least 2 days prior to tightening and setting of cable restrainer units.

The following materials shall be furnished to the Engineer for testing at the manufacturer's plant:

1. One sample cable assembly, consisting of a cable properly fitted with a swaged fitting and right hand thread stud at both ends, three (3) feet in total length, for each 200 cable assemblies or fraction thereof produced. In no case shall less than one sample of the cable assembly be furnished.
2. One percent of the cable yield indicators, but not fewer than 8, produced from each mill heat.
3. Two disc springs of each size produced from each mill heat.

Free ends of cable for restrainer units shall be securely wrapped at each end to prevent separation.

An approved thread locking system, consisting of a cleaner, primer and anaerobic adhesive, shall be applied where shown on the plans. Lubricants and foreign materials shall be removed from the threaded areas of both parts using the cleaner and small wire brush. The primer shall be applied to cover the threaded areas of both parts. The anaerobic adhesive shall be applied to fill the male threads in the area of the final position of the nut. The nut shall be installed at the location or to the torque shown on the plans, and an additional fillet of anaerobic adhesive shall be applied completely around the exposed junctions of the nut and male part.

Unless otherwise specified, steel parts shall conform to the requirements in AASHTO M 183. Steel for bearing bars or pins shall conform to the requirements in AASHTO M 183 or ASTM A 576 Grade 1030 (AISI 1030) and shall be other than rimmed or capped steel.

Steel parts shall be galvanized in conformance with the provisions in these special provisions. Holes may be drilled after galvanizing provided all holes are repaired as provided in these special provisions.

Elastomeric pads shown with restrainer units shall conform to the provisions in "Elastomeric Bearings" of the Standard Specifications. Pads may consist of elastomer only regardless of thickness. Laminated reinforcement will not be required.

Polyvinyl chloride (PVC) pipe shall be commercial quality.

Each seismic restrainer unit shall consist of the number of cable units shown on the plans.

GALVANIZING

All components of seismic restrainer units, except disc springs, shall be galvanized in accordance with AASHTO M111 or M232 as applicable. Galvanizing of material shall be performed after fabrication.

Fabrication shall include all operations such as shearing, cutting, punching, forming, drilling, milling, and bending.

Components of bolted assemblies shall be galvanized separately before assembly.

Tapping of nuts or other internally threaded parts to be used with zinc coated bolts, anchor bars or studs shall be done after galvanizing and shall conform to the requirements for thread dimensions and overtapping allowances in ASTM A563.

Galvanized surfaces that are abraded or damaged at any time after the application of the zinc coating shall be field repaired in accordance with ASTM A780, except noted below:

Galvanized surfaces that are abraded or damaged at any time after the application of the zinc coating shall be repaired by thoroughly wire brushing the damaged areas and removing all loose and cracked coating, after which the cleaned areas shall be painted with 2 applications of un-thinned zinc-rich primer (organic vehicle type) of a type approved by the Engineer. Aerosol cans shall not be used. Thickness of repair shall be not less than 3.5 mils. The Engineer will be the sole judge of the severity of damaged areas for purposes of repair or replacement.

CORROSION RESISTANT COATINGS

In addition to galvanization, cable restrainers shall have the following corrosion protection:

- A. The cables shall be fully coated with corrosion inhibiting grease and then encapsulated by a smooth, high-density polyethylene (HDPE) sheath.
- B. The swaged fittings and portion of the adjacent sheathed cable and threaded stud shall be covered with a mastic-lined heat shrink tubing.
- C. Cable yield indicators, washers, disk springs, nuts, and threaded studs shall be coated with a prime coat of red calcium sulphonate penetrant.
- D. Cable yield indicators, washers, disk springs, nuts, and the portions of threaded studs from the outer face of the nuts to and including the end of the rods shall be coated with a finish coat of gray calcium sulphonate/alkyd.

The grease, sheath, and heat shrink tubing, and the prime and finish coatings shall be applied at the manufacturer's plant, except that no finish coat shall be applied to any portion of the threaded stud that is within 40 mm from the exposed end of the stud. After the installation of cable restrainers is completed, all components described in item D above, which are accessible, shall be recoated with the finish coat.

The nuts shall be hot dipped galvanized conforming to the requirements of ASTM Designation: A563.

The materials to be furnished to the Engineer as specified in the "Materials Section" of this provision shall be furnished with all manufacturer's plant applied coatings.

The corrosion inhibiting grease shall fill all space between strand wires and shall encapsulate the strand giving an encasement diameter at least 0.12-mm greater than the diameter of the bare strand. The sheath shall be hot melt extruded onto the strand or shall be shop applied by an approved method that assures that all spaces between the sheath and the strand, and between the strand wires are filled with corrosion inhibiting grease.

The corrosion inhibiting grease shall 1) provide a continuous nonbrittle film of corrosion protection to the cable and lubrication between the cable and the sheathing, 2) resist flow from the sheathing, 3) be chemically stable and nonreactive with the cable, sheathing material and concrete, and 4) be organic with appropriate polar, moisture displacing, and corrosion inhibiting additives.

The corrosion inhibiting grease shall have the physical properties listed in Table 3.2.1 of the Post Tensioning Manual, Fourth Edition, but the Post Tensioning Institute and as modified below. At least 40 days before use, a sample from the lot to be used and test results shall be provided for the corrosion inhibiting grease.

TEST	REQUIREMENT	ASTM DESIGNATION
Water Soluble Ions: Nitrates	10g/kg maximum	D 3867
Corrosion Tests: 5 percent Salt Fog at 38°C. 125 µm coating on 76 mm x 152 mm Q panel Type S, 1000 hrs minimum	Grade 7 or better	B 117, D 610
Compatibility with sheathing: Hardness change and volume change of polymer after exposure to grease 40 days at 66°C.	15 percent maximum 10 percent maximum	D 4289, Except use D 792 for density

A Certificate of Compliance conforming to the Special Provisions shall be furnished to the Engineer certifying that the corrosion inhibiting grease complies with the requirements herein if sample and test results are not provided for the lot used.

HDPE sheathing shall 1) have a density between 940 kg/m³ and 960 kg/m³ as measured in conformance with ASTM Designation: D 792, A-2, 2) have a minimum wall thickness of 2 mm, 3) have sufficient strength to prevent damage during construction operations, 4) be watertight, 5) be chemically stable without embrittlement or softening, 6) be nonreactive with concrete, steel, or corrosion inhibiting grease, and 7) be flush with the ends of the galvanizing swaged fittings. Burned or damaged HDPE sheathing will be rejected.

The mastic-lined heat shrink tubing shall be placed over the galvanized swaged fitting and, after shrinking, shall extend a length of 50 mm onto both the sheathed cable and the threaded stud.

Heat shrink tubing shall conform to the requirements in Military Specification MIL-DTL-23053/15, UL Standard 468D, ANSI C119.1 or the Western Underground Guide Nos. 2.4 and 2.5.

The shrink tubing shall be installed as a continuous tube. Cutting the tube lengthwise and wrapping it around the assembly will not be permitted.

All sharp edges and burrs that may damage the shrink tubing shall be removed before applying the shrink tubing.

The inside surface of the shrink shall be kept free of foreign debris prior to and during application. All oil, dirt, grease, solvents, or other deleterious material shall be removed from the outer HDPE sheathing and the cable restrainer assembly immediately prior to applying the shrink tubing.

The shrink tubing shall be uniformly heated to the minimum temperature of 121°C, from the center of the shrink tube region outward, until the tubing is completely shrunk and the adhesive is protruding from both ends of the tubing. The heat source shall be an electric heat gun capable of producing the uniform temperature. The heating method shall not burn or damage the shrink tubing or the HDPE sheathing. Any damaged shrink tubing will be rejected. Damage shall include cuts, tears, pinholes, burns, or other defects.

Prior to coating with the prime coat of red calcium sulphionate penetrant, cable yield indicators, washers, disk springs, nuts, and threaded rods shall be steam cleaned in conformance with the provisions in the "Steam Cleaning," of this provision.

Pigment composition and physical properties of the penetrant shall conform to the following:

PROPERTY	REQUIREMENT	TEST METHOD
Total Pigment Content:	20 to 26 percent	Federal Test Method Standard (FTMS) No. 141, Method 4021.1
Pigment Component:		
Synthetic Red Iron Oxide	19 to 23 percent	ASTM D 3721
Zinc Hydroxy Phosphite	33 to 37 percent	ASTM D 4462
Barium Sulfate	40 to 48 percent	ASTM D 602
Nonvolatile Content	60 percent, minimum	ASTM D 2369
Consistency	60 to 165 grams (50 to 75 KU)	ASTM D 562
Density	1.139±0.024 grams per milliliter	ASTM D 1475
Drying Time, Dry to Recoat, 100 µm wet film	24 hours	ASTM D 1640
Flash Point	40°C, minimum	ASTM D 3278
Salt Fog Performance, 25 to 50 µm dry film on SSPC-SP5 blasted cold-rolled steel panel	500 hours, no rust or creepage at scribe	ASTM B 117

The penetrant vehicle shall consist of 75 to 79 percent calcium sulphonate solution and 21 to 25 percent driers and aliphatic hydrocarbons.

The total dry film thickness of the prime coat shall be not less than 25 µm.

Disk springs shall be color coded, as shown on the plans, after application of the prime coat of calcium sulphonate penetrant.

Pigment composition and physical properties of the finish coat shall conform to the following:

PROPERTY	REQUIREMENT	TEST METHOD
Total Pigment Content:	22 to 28 percent	FTMS No. 141, Method 4021.1
Pigment Component:		
Titanium Dioxide	40 to 43 percent	ASTM D 476, Type III or IV
Carbon Black	0.04 to 1.00	ASTM D 561
Zinc Hydroxy Phosphite	28 to 32 percent	ASTM D 4462
Barium Sulfate	26 to 30 percent	ASTM D 602
Nonvolatile Content	70 percent, minimum	ASTM D 2369
Consistency	250 to 600 grams (90 to 120 KU)	ASTM D 562
Density	1.139±0.024 grams per milliliter	ASTM D 1475
Drying Time, 100 µm wet film		ASTM D 1640
Dust Free	1 to 4 hours	
Tack Free	5 to 12 hours	
Dry Hard	24 to 48 hours	
Flash Point	40°C, minimum	ASTM D 3278
Sag Resistance	300 µm	FTMS 4494
Salt Fog Performance, 100 µm dry film on SSPC-SP5 blasted cold-rolled steel panel	1000 hours, no more than 1 percent rust undercutting, blistering, or peeling	ASTM B 117

The finish coat vehicle shall consist of 77 to 81 percent calcium sulphonate solution, 12 to 16 percent modified alkyd and 7 to 9 percent driers and aliphatic hydrocarbons.

The finish coat color shall match Federal Standard 595B, No. 26373. The total dry film thickness of the finish coat shall be not less than 200 µm.

The calcium sulphonate solution for the prime and finish coats shall be on the Department's list of approved products that are available from the Transportation Laboratory.

STEAM CLEANING

All dirt, grease, loose chalky paint or other foreign material which has accumulated on the previously painted or galvanized surfaces shall be removed with a steam cleaning apparatus which shall precede all other phases of cleaning. The temperature of the steam produced by the steam cleaning apparatus shall be between 130°C and 190°C at the nozzle. Gloss on the existing paint shall be removed without removing sound paint. Areas of gloss on the existing paint that are not removable by steam cleaning and rinsing, shall be lightly roughened by sanding with 100- to 200-grit sandpaper. Any paint, which becomes loose, curled or lifted or loses its bond with the preceding coat or coats after steam cleaning, shall be removed to sound paint or metal surface by the Contractor, at the Contractor's expense.

A biodegradable detergent shall be either added to the feed water of the steam generator or applied to the surface to be cleaned. The detergent shall be of such composition and shall be added or applied in such quantity that the cleaning as provided in the above paragraph is accomplished.

Steam cleaned surfaces shall be rinsed clean with fresh water to remove any residue, detergent or other foreign material.

Steam cleaning shall not be performed more than 2 weeks prior to painting or other phases of cleaning. Subsequent painting shall not be performed until the cleaned surfaces are thoroughly dry and in no case in less than 24 hours after cleaning.

CONSTRUCTION REQUIREMENTS:

Placing

Seismic restrainers shall be installed through PVC pipe in concrete enclosures as shown on the plans. The restrainers shall be installed after the concrete enclosures are poured.

METHOD of MEASUREMENT:

Seismic restrainer units will be measured by each unit. A group of _____ cables and associated components together will be considered as a single unit.

METHOD of PAYMENT:

The contract prices paid per each for seismic restrainer units shall include full compensation for furnishing all labor, materials (including non-metallic materials for restrainer units), tools, equipment and incidentals, and for doing all the work involved in furnishing and installing the seismic restrainer units, complete in place, as shown on the plans, and as specified in these special provisions, and as directed by the Engineer.

If a portion or all bridge joint restrainer units are fabricated more than 300 airline miles from Columbia, additional shop inspection expenses will be sustained by the State. Whereas it is and will be impracticable and extremely difficult to ascertain and determine the actual increase in these expenses, it is agreed that payment to the Contractor for the joint restrainer units item of work will be reduced \$5000 for each fabrication site located more than 300 air line miles from Columbia and an additional \$3000 (\$8000 total) for each fabrication site located more than 3000 air line miles from Columbia.

<u>Item No.</u>	<u>Pay Item</u>	<u>Pay Unit</u>
7093600	Seismic Restrainer (___ Cable Unit)	Each

ELASTOMERIC CONCRETE FOR EXPANSION JOINT HEADERS

1.0 Elastomeric Concrete for Expansion Joint Headers

1.1 Scope

Furnish all required labor, equipment, and materials and perform all operations necessary for installing the elastomeric concrete in accordance with the details shown on the Plans and with the requirements of this Specification.

1.2 Materials

Provide elastomeric concrete that is a mixture of a two-part polymer consisting of polyurethane and/or epoxy and kiln-dried aggregate, with the materials being supplied as a unit by the Manufacturer.

Provide materials that comply with the following minimum requirements at either 14 days or at the end of the specified curing time.

ELASTOMERIC CONCRETE PROPERTIES	TEST METHOD	MINIMUM REQUIREMENT
Compressive Strength, psi	ASTM D 695	2000
5% Deflection Resilience	ASTM D 695	95%
Splitting Tensile Strength, psi	ASTM D 3967	625
Bond Strength to Concrete, psi	ASTM C 882	450
Durometer Hardness	ASTM D 2240	50

BINDER PROPERTIES (without aggregate)	TEST METHOD	MINIMUM REQUIREMENT
Tensile Strength, psi	ASTM D 638	1000
Ultimate Elongation	ASTM D 638	150%
Tear Resistance, lb/in	ASTM D 624	200

In addition to the requirements above, provide elastomeric concrete that is resistant to water absorption, is resistant to chemical, UV, and ozone exposure, and is capable of withstanding temperature extremes.

Furnish a Manufacturer's certification verifying that the materials satisfy the above requirements. Provide samples of elastomeric concrete to the RCE, if requested, to independently verify conformance with the above requirements.

Provide material in packages clearly marked by the Manufacturer with the following information:

- Manufacturer's name and address
- Product Name
- Date of Manufacture
- Expiration Date
- Batch Number
- Mixing Instructions
- Storage and Handling Requirements

- Material Safety Data Sheets

1.3 Construction Requirements

1.3.1 Storage

Prior to beginning construction, deliver sufficient materials to the job-site to construct entirely the elastomeric concrete headers as detailed on the Plans. Store materials delivered to the job-site in the original unopened containers within an appropriate facility capable of maintaining storage conditions consistent with the requirements of the Manufacturer.

1.3.2 Installation

Provide a Manufacturer's representative on the job-site during the first installation of the elastomeric concrete to ensure that all aspects of the installation is in compliance with the Manufacturer's requirements. Do not proceed with installation until the weather conditions meet the requirements of the Manufacturer.

Place a bond breaker on the area where the elastomeric concrete headers are to be constructed before placing the asphaltic concrete overlay over the joints. After the overlay is placed, sawcut the overlay to the width shown on the plans, and remove the bond breaker and overlay material in the joint area.

Clean and dry the bonding surfaces and prepare joint surfaces according to the Manufacturer's instructions. Prepare and apply a primer to areas specified by the Manufacturer and in accordance with Manufacturer's instructions. Mix and place the elastomeric concrete, in accordance with the Manufacturer's instructions, into the prepared area on each side of the expansion joint.

Form and cast the elastomeric concrete headers to smoothly match the surface of the finished roadway. Finish the surface to a moderately rough texture such as that produced by a wood float. Protect the elastomeric concrete header material from damage, and allow the headers to cure properly prior to opening the work area to traffic. Do not open to traffic without the written approval of the Manufacturer. Provide a copy of this approval to the RCE.

1.3.3 Warranty

Provide a Manufacturer's warranty that the elastomeric concrete will not delaminate, debond, rut, or otherwise fail to perform for five years after the time the bridge is opened. Include in the warranty that the Manufacturer is required to repair or replace, at the discretion of SCDOT, all elastomeric joint headers that fail during the warranty period at no additional cost to the SCDOT and within three months of SCDOT's written request to do so. Also include the SCDOT file number and the estimated date the bridge will be opened. Do not include in the warranty acts of God or failures adjacent to the installation. If the joint needs to be repaired or replaced by the Manufacturer before the warranty expires, SCDOT will provide, with three weeks notice, traffic control for a time interval specified by the Manufacturer. Include in the warranty that if the replacement or repair affects the expansion joint material, the Manufacturer is required to install new expansion joint material. Replaced or prepared installations must use materials meeting the requirements of this Specification and the original Plans.

1.4 Measurement

No separate measurement for payment will be made for furnishing and installing of elastomeric concrete, providing the Manufacturer's representative, or for furnishing the warranty.

1.5 Payment

Include all costs of elastomeric concrete in the contract unit price bid for Expansion Joint System with Concrete Header.

STATE OF SOUTH CAROLINA)
)
COUNTY OF)

CLAIM CERTIFICATION

Personally appeared before me _____ who being duly sworn deposes and states that:

1. He is _____ of _____.
Position Name of Contractor
2. He has submitted a claim on behalf of _____.
Name of Contractor
3. SCDOT and the claim is submitted pursuant to Section 105.16 of the Standard Specifications.
4. The claim was prepared in accordance with the requirements of Section 105.16 and to the extent available all information required by Section 105.16 is included.
5. The claim is made in good faith.
6. The supportive data are accurate and complete to the best of my knowledge.
7. The amount of claim accurately reflects the amount that I in good faith believe is the DOT's liability.

SWORN to before me this _____ day of _____, _____.

Notary Public for South Carolina
My commission expires: _____

CONTRACTOR NOTICE OF CLAIM

DATE: _____

FILE NO. _____

CONTRACTOR: _____

NOTICE OF CLAIM FOR ADJUSTMENT DUE TO: (circle as appropriate)

ALTERATION
OF PLANS

CHANGED/DIFFERING
SITE CONDITIONS

DELAY/SUSPENSION
OF WORK

EXTRA WORK

TIME EXTENSION

OTHER

NATURE OF THE EVENT:

CAUSE OF THE EVENT:

IMPACT OF THE EVENT: (on time of performance on contract price)

In the event this issue is not resolved by Supplemental Agreement or Force Account Order, the Contractor shall submit to the Department at the appropriate time a fully detailed request ("Claim") for additional time or compensation.

Copy of this notice was delivered to the RESIDENT ENGINEER on

_____, 20__ by_____.

SIGNED: _____
(Contractor's Representative)

RECEIVED BY:

RESIDENT ENGINEER

DATE: _____

Director of Construction

Date Sent to FHWA_____

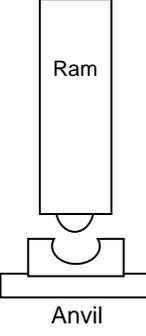
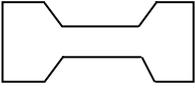
File No.		Project No. (PIN):				
County:		Route:				
Description:						
Contractor:						
	Hammer	Manufacturer:	Model:			
		Type:	Serial No.:			
		Rated Energy (k-ft)	at	Length of stroke (ft)		
		Lead Size (in):				
		Modifications:				
		Note: Attach any hammer modification specifications. Manufacturer's Specifications may be required if hammer is not found in Wave Equation database.				
		Date of Last Maintenance:				
		Type of Maintenance:				
Performed By:						
	Striker Plate	Weight (kips):				
		Diameter (in):	Thickness (in):			
	Hammer Cushion	Description:				
			Material Description	No. of Layers	Modulus of Elasticity (ksi)	Thickness (in)
		1				
		2				
		Area (sq. in):		Total Thickness (in)		
Coefficient of Restitution:						
	Pile Cap (Helmet)	Dimension:				
		Pile Cap Weight (kips):				
		Inserts Weight (kips):				
	Pile Cushion	Material:				
		Thickness (in.)	Area (sq. in):			
		Modulus of Elasticity (ksi):				
		Coefficient of Restitution:				
	Pile	Pile Type/Size & Pile Point:				
		Total Pile & Point Length (ft):	Exposed Pile Point Length (ft):			
		Pile Cross-Sectional Area (sq.in):				
		Pipe Pile Wall Thickness (in):				
		Pile Tip Description:				
		Splice Description:				
		Splice Location From Pile Top (ft):				
		Concrete Pile Strength, f'_c (psi):				
		Steel Pile Yield Strength, F_y (ksi):				
Note: Within 30 calendar days after award of contract or no later than 30 days before driving the first pile, submit form and Pile Installation Plan to the Geotechnical Design Support Engineer, with copy to the Bridge Construction Engineer and RCE.						
SCDOT – Preconstruction Support Geotechnical Design Support Engineer P.O. Box 191 Columbia, SC 29202-0191 Telephone (803) 737-1571 FAX (803) 737-0608		Submitted By:				
		Title:				
		Telephone No.	()-	Date:		

SCDOT

DRILLED SHAFT LOG (REV 06-03-02)

Project Name _____	Page	1	of	6
File No. _____	Bent No.	_____		
Contractor _____	Shaft No.	_____		
Completed By Contractor DS Foreman - _____	Date	/	/	Station _____
Reviewed By SCDOT Inspector - _____	Date	/	/	Offset _____

		Construction		Temporary
Date Cased _____	Casing Type: _____			
Date Opened _____	Casing Dimension (OD): _____			
Date Poured _____	Bottom of Casing Elevation (FT) _____			
Elevation (ft) <div style="border: 1px solid black; height: 100%; width: 100%;"></div>	Top of Casing Elevation (FT) _____			
	Diameter of Rock Socket (IN) _____			
	Diameter of Shaft (IN) _____			
	Mud-line/Ground Surface Elevation (FT) _____			
	Wet & Dry Shaft Length (FT) _____			
	Rock Socket Length (FT) _____			
	Top of Shaft Elevation (FT) _____			
	Tip Elevation (FT) _____			
	Constructed Shaft Length (FT) _____			
	Testing/Other: _____			
	Volume of Concrete: _____	Theoretical (VT) CY _____		
	OP = VP-VT = _____ UP = VT - VP= _____	Actual (VP) CY _____		
	Reinforcement Cage Installed: _____	Type _____		
	Duration of Pour (min) _____			
	Legend			
TOC Top of Casing	<div style="border: 1px solid black; width: 30px; height: 15px; display: inline-block;"></div>	Sand		
TOG Top of Ground				
TOS Top of Shaft	<div style="border: 1px solid black; width: 30px; height: 15px; display: inline-block;"></div>	Silt		
TOR Top of Rock				
BOC Bottom of Casing	<div style="border: 1px solid black; width: 30px; height: 15px; display: inline-block;"></div>	Clay		
BOS Bottom of Shaft				
BOR Bottom of Rock	<div style="border: 1px solid black; width: 30px; height: 15px; display: inline-block;"></div>	Rock		
← Water Level				
Completed by _____				
Contractor DS Foreman/Engineer				
Reviewed by _____				
SCDOT Inspector/Engineer				
Notes: _____				
Shaft location variance at top: _____				

HOW TO COMPLETE THE DRILLED SHAFT LOG



Project Name _____		Page _____ of _____	
Project No. _____		Plan No. _____	
Contract or _____ 1 _____		Shaft No. _____	
Inspected By _____		Date 1 1 _____	Station _____
Approved By _____		Date 1 1 _____	City _____

Date Closed _____ 2 _____ Date Opened _____ Date Poured _____	Coating Type _____ Coating Dimension _____ Bottom of Coating Elevation (ft) _____ Diameter of Rock Socket (in) _____ Diameter of Overburden Shaft (in) _____ Natural Ground Surface Elevation (ft) _____ 3 _____ Overburden Shaft Length (ft) _____ Rock Socket Length (ft) _____ Cutoff Elevation (ft) _____ Top Elevation (ft) _____ Constructed Shaft Length (ft) _____ Facing (ft) _____ Volume of Concrete Theoretical (cy) _____ Actual (cy) _____ Reinforcement Cage Installed Type _____ Duration of Pour (min) _____ Legend: FOC: Top of Coating <input type="checkbox"/> Sand FOG: Top of Ground <input type="checkbox"/> Soil FOS: Top of Shaft <input type="checkbox"/> Clay FOR: Top of Rock <input type="checkbox"/> Rock BOC: Bottom of Coating <input type="checkbox"/> BOS: Bottom of Shaft <input type="checkbox"/> Water Level _____ Inspected by _____ Approved by _____ 5 _____ Distribution _____ _____ _____
--	---

Illustration:

Fill in every blank on the form. If it does not apply put an "N/A" or a long dash.

Use pencil – but never erase. If you need to change something, strike a single line through the item and insert the correct information above it. If there is insufficient room to make a note, footnote the item and go to the bottom of the page, or use a separate page.

1. Heading:
 - Fill in before drilling starts.
 - Be sure to print your name and the start date of drilling.
 - The Geotechnical Engineer will sign approval line.
2. Shaft Data: - Fill in appropriate dates, elevations, and diameters.
3. Concrete Data: Record data from the Concrete Volumes form.
4. Construct Shaft Illustration using the symbols provided.
5. Fill in "Inspected by" and "Distribution".



DRILLED SHAFT LOG (REV 06-03-02)
SAMPLE 1 Construction Casing

Project Name	Replace Bridge over Cooper Creek along US-322	Page	1	of	6
File No.	4.995	Bent No.	3		
Contractor	Drilled Shaft, Inc.	Shaft No.	3		
Completed By	DS Foreman - John Q. Doe	Date	06/05/02	Station	508 + 36
Reviewed By	Inspector - John Smith	Date	06/05/02	Offset	24 FT. Right

Date Cased 06/04/02
 Date Opened 06/04/02
 Date Poured 06/05/02

Casing Type:
 Casing Dimension (OD):
 Bottom of Casing Elevation (FT)
 Top of Casing Elevation (FT)
 Diameter of Rock Socket (IN)
 Diameter of Shaft (IN)
 Mud-line/Ground Surface Elev. (FT)
 Wet & Dry Shaft Length (FT)
 Rock Socket Length (FT)
 Top of Shaft Elevation (FT)
 Tip Elevation (FT)
 Constructed Shaft Length (FT)

Construction	Temporary
Steel	
48.0 IN.	
86.0 FT. msl	
101.0 FT. msl	
42.0 IN.	
37 Ft. @ +48.0 IN. & 15 FT. @ 47 IN.	
100.0 FT. msl	
52.0 FT.	
10.0 FT. @ 42IN.	
101.0 FT. msl	
39.0 FT. msl	
62.0 FT.	

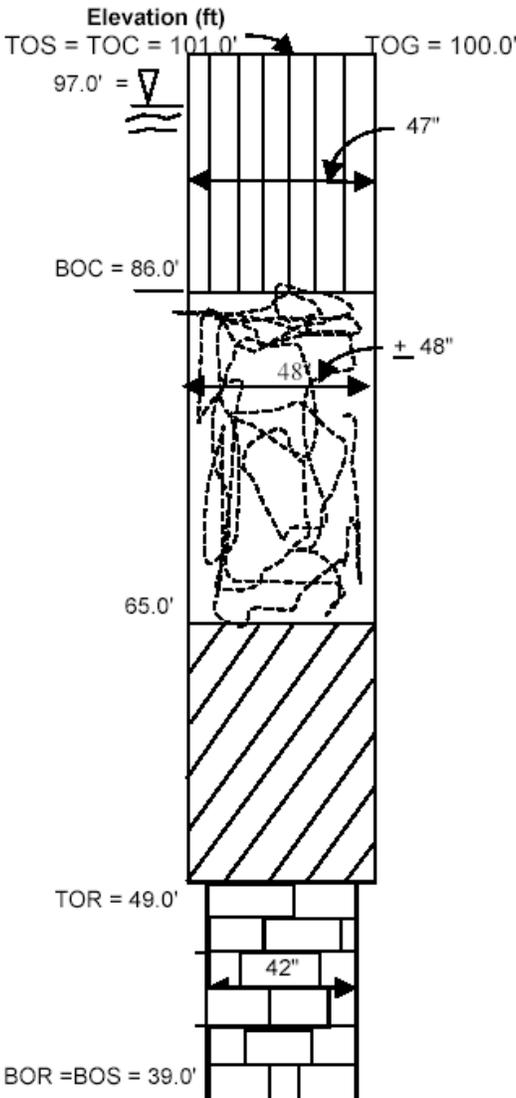

Testing/Other: Slurry, Slump, Air, Compression Cylinders, & CSL

Volume of Concrete: Theoretical (VT) CY 27.2
 OP = VP - VT = 0.6 CY UP = VT - VP =
 Actual (VP) CY 27.8
 Reinforcement Cage Installed: Type Spiral
 Duration of Pour (min) 100 Min.

Legend

TOC	Top of Casing		Sand
TOG	Top of Ground		Silt
TOS	Top of Shaft		Clay
TOR	Top of Rock		Rock
BOC	Bottom of Casing		
BOS	Bottom of Shaft		
BOR	Bottom of Rock		

Water Level

Completed by _____
 Contractor DS Foreman/Engineer - John Q Doe
 Reviewed by _____
 SCDOT Inspector/Engineer - John Smith
 Notes: _____

Shaft location variance at top: 2" after plan station & 1" right.



DRILLED SHAFT LOG (REV 06-03-02)
SAMPLE 2 Temporary Casing

Project Name	Replace Bridge over Cooper Creek along US-322	Page	1	of	6
File No.	4.995	Bent No.	6		
Contractor	Drilled Shaft, Inc.	Shaft No.	3		
Completed By Contractor	DS Foreman - John Q. Doe	Date	06/05/02	Station	508 + 36
Reviewed By SCDOT	Inspector - Jane Smith	Date	06/05/02	Offset	24 FT. Right

<p>Date Cased <u>06/04/02</u></p> <p>Date Opened <u>06/04/02</u></p> <p>Date Poured <u>06/05/02</u></p>	<p>Casing Type:</p> <p>Casing Dimension (OD):</p> <p>Bottom of Casing Elevation (FT)</p> <p>Top of Casing Elevation (FT)</p> <p>Diameter of Rock Socket (IN)</p> <p>Diameter of Shaft (IN)</p> <p>Mud-line/Ground Surface Elev. (FT)</p> <p>Wet & Dry Shaft Length (FT)</p> <p>Rock Socket Length (FT)</p> <p>Top of Shaft Elevation (FT)</p> <p>Tip Elevation (FT)</p> <p>Constructed Shaft Length (FT)</p> <p>Testing/Other: Slurry, Slump, Air, Compression Cylinders, & CSL</p> <p>Volume of Concrete:</p> <p>OP = VP-VT = <u>0.5 CY</u> UP = VT - VP =</p> <p>Reinforcement Cage Installed:</p> <p>Duration of Pour (min)</p>	<table border="1"> <thead> <tr> <th>Construction</th> <th>Temporary</th> </tr> </thead> <tbody> <tr> <td></td> <td>Steel</td> </tr> <tr> <td></td> <td>48.0 IN.</td> </tr> <tr> <td></td> <td>86.0 FT.</td> </tr> <tr> <td></td> <td>101.0 FT.</td> </tr> <tr> <td></td> <td>42.0 IN.</td> </tr> <tr> <td></td> <td>+ 48.0 IN.</td> </tr> <tr> <td></td> <td>100.0 FT. msl</td> </tr> <tr> <td></td> <td>51.0 FT.</td> </tr> <tr> <td></td> <td>10.0 FT.</td> </tr> <tr> <td></td> <td>100.0 FT. msl</td> </tr> <tr> <td></td> <td>39.0 FT. msl</td> </tr> <tr> <td></td> <td>61.0 FT.</td> </tr> </tbody> </table> <p>Type: <u>Welded Hoops</u></p> <p>100 Min.</p>	Construction	Temporary		Steel		48.0 IN.		86.0 FT.		101.0 FT.		42.0 IN.		+ 48.0 IN.		100.0 FT. msl		51.0 FT.		10.0 FT.		100.0 FT. msl		39.0 FT. msl		61.0 FT.
Construction	Temporary																											
	Steel																											
	48.0 IN.																											
	86.0 FT.																											
	101.0 FT.																											
	42.0 IN.																											
	+ 48.0 IN.																											
	100.0 FT. msl																											
	51.0 FT.																											
	10.0 FT.																											
	100.0 FT. msl																											
	39.0 FT. msl																											
	61.0 FT.																											

Elevation (ft)

TOTC = 101.0'

TOS & TOG = 100.0'

97.0' =

BOTC = 86.0'

65.0'

TOR = 49.0'

BOR = BOS = 39.0'

48" ± 48"

42"

Legend

TOC	Top of Casing		Sand
TOG	Top of Ground		Silt
TOS	Top of Shaft		Clay
TOR	Top of Rock		Rock

Water Level

Completed by _____

Contractor DS Foreman/Engineer - John Q Doe

Reviewed by _____

SCDOT Inspector/Engineer - Jane Smith

Notes:

Shaft location variance at top: 1" after plan station & 4" left. Called Bridge Construction Engineer prior to pour. Received verbal approval to cast concrete from BCE. Contractor told to submit letter covering this shaft variance.



DRILLED SHAFT EXCAVATION LOG (REV 06-03-02)

Project Name _____	Page <u>2</u> of <u>6</u>
File No. _____	Bent No. _____
Contractor _____	Shaft No. _____
Completed By Contractor <u>DS Foreman -</u> Date <u>/ /</u>	Station _____
Reviewed By SCDOT <u>Inspector -</u> Date <u>/ /</u>	Offset _____

Note: Preaugering not allowed when using construction casing.

Casing Information					
ID	OD	Top Elev.	Length	Bot. Elev.	
_____	_____	_____	_____	_____	Soil Auger Diam. _____
_____	_____	_____	_____	_____	Rock Core Diam. _____
_____	_____	_____	_____	_____	Ground Surface Elev. _____
_____	_____	_____	_____	_____	Water Table Elev. _____
_____	_____	_____	_____	_____	Reference Elev. _____
_____	_____	_____	_____	_____	Drilling Mud _____
Notes _____					

Depth ()	Elev. ()	Time		Soil Description and Notes
			In	
			Out	
			In	
			Out	
			In	
			Out	
			In	
			Out	
			In	
			Out	
			In	
			Out	
			In	
			Out	

HOW TO COMPLETE THE DRILLED SHAFT EXCAVATION LOG



Project Name		Page <input type="text"/> of <input type="text"/>	
Project No.		Plan No.	
Contract or		Sheet No.	
1		Date <input type="text"/> / <input type="text"/> / <input type="text"/>	
Inspected By		Station	
Approved By		Chief	

Casing Information				Soil Auger Diam.	
ID	OD	Top Elev.	Length	Ref. Elev.	Ground Surface Elev.
2				3	
Notes					

Depth	Elev.	Time	Soil Description and Notes
		In	6
		Out	
		In	5
		Out	
		In	4
		Out	
		In	3
		Out	
		In	2
		Out	
		In	1
		Out	

Fill in every blank on the form. If it does not apply put an "N/A" or a long dash.

Use pencil – but never erase. If you need to change something, strike a single line through the item and insert the correct information above it. If there is insufficient room to make a note, footnote the item and go to the bottom of the page, or use a separate page.

1. Heading:
 - Fill in before drilling starts.
 - Be sure to print your name and the start date for drilling.
 - The Geotechnical Engineer will sign approval line.

2. Casing:
 - Measure Length (L) in the field.
 - Surveyor provides Top of Casing elevation (TE).
 - Compute bottom elevation(BE): $TE-L=BE$

3. Site Data
 - Soil Auger diameter – measure and record in inches.
 - Ground surface elev. – provided by surveyor.
 - Water table elev. – measure w/tape in hole before slurry is introduced (if applicable).
 - Water table may need to be estimated from seepage in dry hole method.
 - Reference Elevation – provided by surveyor.
 - Drill mud – If used, complete the "**Slurry Inspection Log**"; compare to Installation Plan

4. Depth/Elevation:
 - Depth (D) can be measured by:
 - 1) Contractor has Kelly bar marked (spot checking only)
 - 2) Weighted tape (for accurate measurements)
 Reference elevation is always known; i.e., template, top of casing, or top of ground.

 - Elevation (E) – compute $TE-D=E$
Enter Depth/Elev. For EVERY change in the soil/rock condition.

5. Time:
 - May use military or 24 hour clock. Be consistent and correct! Remember that shaft drilling can occur over several days, so be sure to mark date changes.

6. Material:
 - Use this form to record all activity during shaft excavation. Label all major soil strata.



**DRILLED SHAFT EXCAVATION LOG (REV 06-03-02)
SAMPLE 1 Construction Casing**

Project Name	Replace Bridge over Cooper Creek along US-322	Page	2	of	6
File No.	4.995	Bent No.	3		
Contractor	Drilled Shaft, Inc.	Shaft No.	3		
Completed By Contractor	DS Foreman - John Q. Doe	Date	06/03/02	Station	508 + 36
Reviewed By SCDOT	Inspector - John Smith	Date	06/03/02	Offset	24 Ft. Right

Note: Preaugering not allowed when using construction casing.

Casing Information: Construction <input checked="" type="checkbox"/> Temporary <input type="checkbox"/>					Soil Auger Diam.	46"
ID	OD	Top Elev.	Length	Bot. Elev.	Rock Core Diam.	42"
47"	48"	101.0 MSL	15'	86.0 MSL	Ground Surface Elev.	100.0 MSL
					Water Table Elev.	97.0 MSL
					Reference Elev.	101.0 MSL
					Drilling Mud	Slurry
Notes Switched to 42" Rock Core @ 52.0' (49.0' MSL) at 1:50 pm.						

Depth (Feet)	Elev. (Ft. MSL)	Time		Soil Description and Notes
1.0	100.0	7:30 am	In	Tan Silty Sand
15.0	86.0	9:00 am	Out	Tan Silty Sand
15.0	86.0	9:10 am	In	Dark Tan Sand
36.0	65.0	11:30 am	Out	Dark Tan Sand
36.0	65.0	11:40 am	In	Dense Silty Sand (PWR) w/Mica
52.0	49.0	1:30 pm	Out	Dense Silty Sand (PWR) w/Mica
52.0	49.0	1:50 pm	In	Very Dense Rock (Granite)
61.0	40.0	4:50 pm	Out	Very Dense Rock (Granite)
61.0	40.0	7:15 am	In	Very Dense Rock (Granite) Continued drilling from previous day
62.0	39.0	7:30 am	Out	Very Dense Rock (Granite) Continued drilling from previous day
			In	
			Out	
			In	
			Out	
			In	
			Out	
			In	
			Out	



**DRILLED SHAFT EXCAVATION LOG (REV 06-03-02)
SAMPLE 2 Temporary Casing**

Project Name	Replace Bridge over Cooper Creek along US-322	Page	2	of	6
File No.	4,995	Bent No.	6		
Contractor	Drilled Shaft, Inc.	Shaft No.	3		
Completed By Contractor	DS Foreman - John Q. Doe	Date	06/03/02	Station	508 + 36
Reviewed By SCDOT	Inspector - Jane Smith	Date	06/03/02	Offset	24 Ft. Right

Note: Preaugering not allowed when using construction casing.

Casing Information: Construction _____ Temporary <u>X</u>					Soil Auger Diam.	46"
ID	OD	Top Elev.	Length	Bot. Elev.	Rock Core Diam.	42"
47"	48"	101.0 MSL	15'	86.0 MSL	Ground Surface Elev.	100.0 MSL
					Water Table Elev.	97.0 MSL
					Reference Elev.	101.0 MSL
					Drilling Mud	Slurry
Notes	Switched to 42" Rock Core @ 52.0' (49.0' MSL) at 1:50 pm.					

Depth (Feet)	Elev. (Ft. MSL)	Time		Soil Description and Notes
1	100.0	7:30 am	In	Tan Silty Sand
15.0	86.0	9:00 am	Out	Tan Silty Sand
15.0	86.0	9:10 am	In	Dark Tan Sand
36.0	65.0	11:30 am	Out	Dark Tan Sand
36.0	65.0	11:40 am	In	Dense Silty Sand (PWR) w/Mica
52.0	49.0	1:30 pm	Out	Dense Silty Sand (PWR) w/Mica
52.0	49.0	1:50 pm	In	Very Dense Rock (Granite)
61.0	40.0	4:50 pm	Out	Very Dense Rock (Granite)
61.0	40.0	7:15 am	In	Very Dense Rock (Granite) Continued drilling from previous day
62.0	39.0	7:30 am	Out	Very Dense Rock (Granite) Continued drilling from previous day
			In	
			Out	
			In	
			Out	
			In	
			Out	
			In	
			Out	



SLURRY INSPECTION LOG (REV 06-03-02)

Project Name			
File Number			
Bent No.	Shaft No.	Brand	Type
Water Source: *		Composition:	Proportions
Date of Initial Hydration	/ /	Mineral Type	
	Time	Additives	

TEST PROPERTIES

Sampling	Before Introduction of Slurry	First 8 Hours During Construction **				Additional Testing		At End of Excavation	Before Concreting Test 1	Before Concreting Test 2
		Test 1	Test 2	Test 3	Test 4	Test 1	Test 2			
Date:										
Time:										
Test Depth at Levels:	Holding Tank						At Bottom	At Bottom	At Bottom	
Density										
Viscosity										
% Sand										
pH										
Cake / Filtrate	N/A									

Notes: * Salt water shall not be used to hydrate the slurry or stabilize the excavation.

** A minimum of 4 sets of tests shall be made during the first 8 hours of slurry use. Slurry sampling and testing shall be observed by the Engineer. When the results show consistent behavior, the testing frequency may be decreased to 1 set every 4 hours of slurry use.

Contractor DS Foreman: _____ Date: / /

SCDOT Inspector: _____ Date: / /

HOW TO COMPLETE THE SLURRY INSPECTION LOG

SLURRY INSPECTION LOG

Project No. _____	1	Composition:	Brand	Type	Proportions
Drilled Shaft No. _____		Mineral Type			
Start Location _____		Additives			
Water Source: ** _____					

TEST PROPERTIES

Sampling	Before Introduction of Slurry	First 8 Hours During Construction *				Additional Testing		At End of Excavation	Before Concreting Test 1	Before Concreting Test 2
		Test 1	Test 2	Test 3	Test 4	Test 1	Test 2			
Date:										
Time:										
Properties:	Test Depth at Level:		3					At Bottom	At Bottom	At Bottom
Density										
Viscosity										
% Sand										
pH										
Cake / Filtrate										

Notes: * A minimum of 4 sets of tests shall be made during the first 8 hours of slurry use. Slurry sampling and testing shall be obtained by the Engineer. When the results show consistent behavior, the testing frequency may be decreased to 1 set every 4 hours of slurry use.

** Saltwater shall not be used to hydrate the slurry _____ the excavation.

4

Contractor Representative: _____ Date: / /

State Inspector: _____ Date: / /

5

1. Heading: - Fill in before drilling starts.
- The Project Resident Engineer will sign approval line.
2. Slurry Data: - Fill in appropriate brands, types, and proportion.
3. Test Data: - Record test data as the testing Inspector performs the tests.
- Note the depth at which the samples were obtained.
- Make sure that a minimum of 4 tests are performed within the first 8 hours of slurry use.
4. Notes: Record any unusual events or results.
5. Fill in "Contractor Representative" and "State Inspector".

Fill in every blank on the form. If it does not apply put an "N/A" or a long dash.

Use pencil – but never erase. If you need to change something, strike a single line through the item and insert the correct information above it. If there is insufficient room to make a note, footnote the item and go to the bottom of the page, or use a separate page.



**SLURRY INSPECTION LOG (REV 06-03-02)
SAMPLE 1 Construction Casing**

Project Name Replace Bridge over Cooper Creek along US-322

File Number 4.995

Bent No. 3 Shaft No. 3

Water Source: * Hydrant (City water)

Date of Initial Hydration 06/03/02 Time 9:00 am

Composition:	Brand	Type	Proportions
Mineral Type	Augua Gel	Bentonite	1400 LBS / 5000 GAL
Additives			

TEST PROPERTIES

Sampling	Before Introduction of Slurry	First 8 Hours During Construction **				Additional Testing		At End of Excavation	Before Concreting Test 1	Before Concreting Test 2
		Test 1	Test 2	Test 3	Test 4	Test 1	Test 2			
Date:	06/04/02	06/04/02	06/04/02	06/04/02	06/04/02		06/05/02	06/05/02	06/05/02	
Time:	11:00 am	1:30 pm	2:30 pm	4:00 pm	5:00 pm		7:30 am	8:15 am	9:20 am	
Test Depth at Levels:	Holding Tank	50 FT	53 FT	58 FT	60 FT		At Bottom	At Bottom	At Bottom	
Density	65	67.1	67.3	65.8	66.3		69.1	66.1	66.3	
Viscosity	33	37	38	36	37		42	38	37	
% Sand	0%	3%	4%	2%	2.5%		10%	2%	2%	
pH	10	9	9	9	9		9	10	10	

Notes: * Salt water shall not be used to hydrate the slurry or stabilize the excavation.

** A minimum of 4 sets of tests shall be made during the first 8 hours of slurry use. Slurry sampling and testing shall be observed by the Engineer. When the results show consistent behavior, the testing frequency may be decreased to 1 set every 4 hours of slurry use.

Note: Side of shaft caked. Cleaned shaft sides.

Contractor DS Foreman: John Q. Doe

Date: 06/05/02

SCDOT Inspector: John Smith

Date: 06/05/02

Page 3 of 6



**SLURRY INSPECTION LOG (REV 06-03-02)
SAMPLE 2 Temporary Casing**

Project Name Replace Bridge over Cooper Creek along US-322

File Number 4.995

Bent No. 6 Shaft No. 3

Water Source: * Hydrant (City water)

Date of Initial Hydration 06/03/02 Time 9:00 am

Composition:	Brand	Type	Proportions
Mineral Type	Augua Gel	Bentonite	1400 LBS / 5000 GAL
Additives			

TEST PROPERTIES

Sampling	Before Introduction of Slurry	First 8 Hours During Construction **				Additional Testing		At End of Excavation	Before Concreting Test 1	Before Concreting Test 2
		Test 1	Test 2	Test 3	Test 4	Test 1	Test 2			
Date:	06/04/02	06/04/02	06/04/02	06/04/02	06/04/02		06/05/02	06/05/02	06/05/02	
Time:	11:00 am	1:30 pm	2:30 pm	4:00 pm	5:00 pm		7:30 am	8:15 am	9:20 am	
Test Depth at Levels:	Holding Tank	50 FT	53 FT	58 FT	60 FT		At Bottom	At Bottom	At Bottom	
Density	65	67.1	67.3	65.8	66.3		69.1	66.1	66.3	
Viscosity	33	37	38	36	37		42	38	37	
% Sand	0%	3%	4%	2%	2.5%		10%	2%	2%	
pH	10	9	9	9	9		9	10	10	

Notes: * Salt water shall not be used to hydrate the slurry or stabilize the excavation.

** A minimum of 4 sets of tests shall be made during the first 8 hours of slurry use. Slurry sampling and testing shall be observed by the Engineer. When the results show consistent behavior, the testing frequency may be decreased to 1 set every 4 hours of slurry use.

Note: Side of shaft caked. Cleaned shaft sides.

Contractor DS Foreman: John Q. Doe

Date: 06/05/02

SCDOT Inspector: Jane Smith

Date: 06/05/02

Page 3 of 6



DRILLED SHAFT INSPECTION LOG (REV 06-03-02)

Project Name	_____	Page	4	of	6
File No.	_____	Bent No.	_____		
Contractor	_____	Shaft No.	_____		
Completed By Contractor	DS Foreman - _____	Date	_____	Station	_____
Reviewed By SCDOT	Inspector - _____	Date	_____	Offset	_____

Type of Drilling Fluid	_____	Shaft Plumbness Check/4'	_____
DS Location Variance at Top	_____	Rebar Cage: Proper # Vert. Bars	_____
Bottom Cleanout Method	_____	Proper # Horiz. Bars	_____
Time/Date Final Cleanout	_____	Side Spacers	_____
Shaft Bottom Elev.	_____	Bottom Spacers	_____
Est. Shaft Bottom Dia.	_____	Ties & Connections	_____

* Based on Compass Direction

Inspected By: _____	Visual _____	Sounding _____	N *	Test just prior to placing Rebar cage <input type="checkbox"/> (inches)
Time Test Started _____				Test just prior to placing concrete <input type="checkbox"/> (inches)
Time Test Finished _____				* Direction
Time Test Started _____				
Time Test Finished _____				

W *	<input type="checkbox"/>	<input type="checkbox"/>	N *	<input type="checkbox"/>	E *
<input type="checkbox"/>	<input type="checkbox"/>	<input type="checkbox"/>	<input type="checkbox"/>	<input type="checkbox"/>	<input type="checkbox"/>

**Note: 50% of base shall have < 1/2 Inch of sediment.
No area of shaft bottom shall be more than 1 1/2 Inches.**

Notes	Comments/Recommendations
_____	_____
_____	_____
_____	_____

Results: _____ Satisfactory	DS Foreman _____	Time _____	Date _____
_____ Unsatisfactory	SCDOT Inspector _____		

NOTE: Specification Tolerances - Location Variance at Top = 3 inches Max. Vertical (Plumbness) = 1 inch per 4 Ft. Max.

HOW TO COMPLETE THE DRILLED SHAFT INSPECTION LOG



Fill in every blank on the form. If it does not apply put an "N/A" or a long dash.

Use pencil – but never erase. If you need to change something, strike a single line through the item and insert the correct information above it. If there is insufficient room to make a note, footnote the item and go to the bottom of the page, or use a separate page.

1. **Heading:**
 - Fill in before drilling starts.
 - Be sure to print your name and the start date of drilling.
 - The Project Resident Engineer or designated representative will sign approval line.

2. **Shaft Status:**

Drill Fluid Check – Responsibility of Contractor. Record density check performed by Contractor or Inspector.

Type of Drill Fluid – record	
a)	Natural
b)	Mineral (commercial)
c)	Plain water
Remember: Polymer slurry not allowed	

 - Bottom Cleanout Method: Observe and record equipment type (i.e., cleanout bucket, air lift, submersible pump, etc.). Must match Installation Plan.
 - Time/Date Final Cleanout: Record when last cleanout performed prior to rebar cage placement.
 - Shaft Bottom Elevation – Use weighted tape to measure; record.
 - Estimate Shaft Bottom Diameter – record auger diameter.

3. **Cage Check:**
 - Reinforcing cage usually checked by others.
 - Proper number of Vertical bars – count and record # of vertical bars in hole; compare to plan.
 - Epoxy – you should never see coated rebar

4. **Shaft Cleanliness:**
 - check procedure being used, record
 - 1) Using S.I.D., visually inspect the shaft bottom in each of a minimum of 5 locations as shown on form.
 - 2) Using a weighted tape, sound the shaft in each of a minimum of 5 locations as shown on form. “Feel” for hard bottom – it translates to clean hole. Remember specifications.

5. **Record Results:**



**DRILLED SHAFT INSPECTION LOG (REV 06-03-02)
SAMPLE 1 Construction Casing**

Project Name	<u>Replace Bridge over Cooper Creek along US-322</u>	Page	<u>4</u>	of	<u>6</u>
File No.	<u>4.995</u>	Bent No.	<u>3</u>		
Contractor	<u>Drilled Shaft, Inc.</u>	Shaft No.	<u>3</u>		
Completed By Contractor	<u>DS Foreman - John Q. Doe</u>	Date	<u>06/05/02</u>	Station	<u>508 + 36</u>
Reviewed By SCDOT	<u>Inspector - John Smith</u>	Date	<u>06/05/02</u>	Offset	<u>24 FT. Right</u>

Type of Drilling Fluid	<u>Bentonite</u>	Shaft Plumbness Check/4'	<u>1/2 In. per 4 Ft.</u>
DS Location Variance at Top	<u>2" After Sta. & 1" Right</u>	Rebar Cage: Proper # Vert. Bars	<u>16 EA # 36 Bars</u>
Bottom Cleanout Method	<u>Airlift</u>	Proper # Horiz. Bars	<u># 19 Bar @ 4 3/8" Spiral</u>
Time/Date Final Cleanout	<u>7:45 am on 06/05/02</u>	Side Spacers	<u>4 EA every 10 Ft.</u>
Shaft Bottom Elev.	<u>39.0 msl</u>	Bottom Spacers	<u>16 EA @ 6" Length</u>
Est. Shaft Bottom Dia.	<u>42 Inches</u>	Ties & Connections	<u>Checked and okay.</u>

Inspected By:	<u>JQD</u>	Visual	<u> </u>	Sounding	<u>X</u>	N *	* Based on Compass Direction
Time Test Started	<u>7:45 am</u>						
Time Test Finished	<u>8:00 am</u>						
Time Test Started	<u>9:10 am</u>						
Time Test Finished	<u>9:25 am</u>						

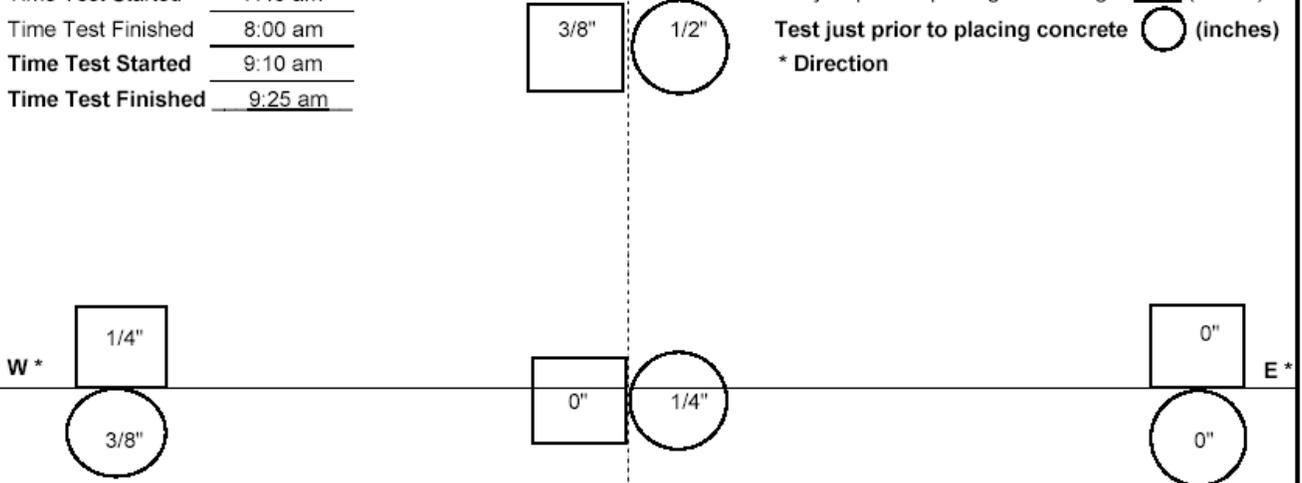

**Note: 50% of base shall have < 1/2 Inch of sediment.
No area of shaft bottom shall be more than 1 1/2 Inches.**

Notes	Comments/Recommendations
80% area < 1/2", first test okay.	Rebar cage placed & concrete ordered after first test.
60% area < 1/2", second test okay.	Concrete placed after second test was okay.

Results:	<u>X</u>	Satisfactory	DS Foreman	<u>John Q Doe</u>
	<u> </u>	Unsatisfactory	SCDOT Inspector	<u>John Smith</u>
			Time	<u>9:25 am</u> Date <u>06/05/02</u>

NOTE: Specification Tolerances - Location Variance at Top = 3 inches Max. Vertical (Plumbness) = 1 inch per 4 Ft. Max.



DRILLED SHAFT INSPECTION LOG (REV 06-03-02)
SAMPLE 2 Temporary Casing

Project Name	<u>Replace Bridge over Cooper Creek along US-322</u>	Page	<u>4</u>	of	<u>6</u>
File No.	<u>4.995</u>	Bent No.	<u>6</u>		
Contractor	<u>Drilled Shaft, Inc.</u>	Shaft No.	<u>3</u>		
Completed By Contractor	<u>DS Foreman - John Q. Doe</u>	Date	<u>06/05/02</u>	Station	<u>508 + 36</u>
Reviewed By SCDOT	<u>Inspector - Jane Smith</u>	Date	<u>06/05/02</u>	Offset	<u>24 FT. Right</u>

Type of Drilling Fluid	<u>Bentonite</u>	Shaft Plumbness Check/4'	<u>1/2 In. per 4 Ft.</u>
DS Location Variance at Top	<u>1" Before Sta. & 4" Left**</u>	Rebar Cage: Proper # Vert. Bars	<u>16 EA # 36 Bars</u>
Bottom Cleanout Method	<u>Airlift</u>	Proper # Horiz. Bars	<u># 19 W Hoops @ 7 IN.</u>
Time/Date Final Cleanout	<u>7:45 am on 06/05/02</u>	Side Spacers	<u>4 EA every 10 Ft.</u>
Shaft Bottom Elev.	<u>39.0 msl</u>	Bottom Spacers	<u>16 EA @ 6" Length</u>
Est. Shaft Bottom Dia.	<u>42 Inches</u>	Ties & Connections	<u>Checked and okay.</u>

* Based on Compass Direction

Inspected By:	<u>JQD</u>	Visual	<u> </u>	Sounding	<u>X</u>	N *
Time Test Started	<u>7:45 am</u>					Test just prior to placing Rebar cage <input type="checkbox"/> (inches)
Time Test Finished	<u>8:00 am</u>					Test just prior to placing concrete <input type="checkbox"/> (inches)
Time Test Started	<u>9:10 am</u>					* Direction
Time Test Finished	<u>9:25 am</u>					

Note: 50% of base shall have < 1/2 Inch of sediment.
No area of shaft bottom shall be more than 1 1/2 Inches.

Notes	Comments/Recommendations
60% area < 1/2", first test okay.	Rebar cage placed & concrete ordered after first test.
60% area < 1/2", second test okay.	Concrete placed after second test was okay.
	** - See note on Page 1.

Results:	<u>X</u> Satisfactory	DS Foreman	<u>John Q Doe</u>
	Unsatisfactory	SCDOT Inspector	<u>Jane Smith</u>
		Time	<u>9:25 am</u>
		Date	<u>06/05/02</u>

NOTE: Specification Tolerances - Location Variance at Top = 3 inches Max. Vertical (Plumbness) = 1 inch per 4 Ft. Max.



DRILLED SHAFT CONCRETE PLACEMENT LOG (REV 06-03-02)

Project Name _____	Page <u>5</u> of <u>6</u>
File No. _____	Bent No. _____
Contractor _____	Shaft No. _____
Completed By Contractor <u>DS Foreman -</u>	Date _____
Reviewed By SCDOT <u>Inspector -</u>	Date _____
	Station _____
	Offset _____

Placement Method _____ Tremie	Volume in Pump Truck _____	# _____	ID _____	Length _____	Volume _____
_____ Pumped	Pump Truck Lines _____	_____	_____	_____	_____
De-airing Method _____ Relief Valve	Pump Truck _____	_____	_____	_____	_____
_____ Plug	_____	_____	_____	_____	_____
_____ Cap	_____	_____	_____	_____	_____
	Total Volume in Lines + Pump Truck _____			$\Sigma =$ _____	
Reference Elev. _____					
Shaft Top Elev. _____	Time First Truck Batched: _____				
Top of Rock Elev. _____	Depth of Water Per Hr. Inside Shaft (Dry Hole Check) _____				
Shaft Bottom Elev. _____	Rebar Cage Top Elev. <u>At Start -</u> _____			<u>At Finish</u> _____	

Truck No.	Concrete Volume	Arrival Time	Start Time	Finish Time	Tremie Depth	Depth To Concrete	Notes
_____ Concrete Volume Delivered					Total Placement Time (Temp. Casing Removed) _____		

							YES	NO
T Casing Removal**	OD _____	Top Elev. _____	Bot. Elev. _____	Start _____	Finish _____	Rebar Cage Centered*	_____	_____
						Rebar Cage Re-centered	_____	_____

Notes * If no, then re-center rebar cage. ** If unable to remove temporary casing, then call Bridge Construction Office.

HOW TO COMPLETE THE DRILLED SHAFT CONCRETE PLACEMENT LOG

Fill in every blank on the form. If it does not apply put an "N/A" or a long dash.

Use pencil – but never erase. If you need to change something, strike a single line through the item and insert the correct information above it. If there is insufficient room to make a note, footnote the item and go to the bottom of the page, or use a separate page.

1. Heading:
 - Fill in before drilling starts.
 - Be sure to print your name and the start date of drilling.
 - The Project Resident Engineer or designated representative will sign approval line.
2. Indicate correct "Placement" and "Dairing" method.
3. Compute and fill in Concrete Volumes: $V = (\pi d^2 / 4) \times L$
4. Fill in as much as possible prior to pour.
5. Record Truck number and amount of concrete.
6. Time:
 - May be military or standard clock. Be consistent and correct.
 - Watch for date changes on late night pours.
7. Depths:
 - Tremie embedment may be measured by markings on the tremie. Depth to concrete may be measured by weighted tape.
8. Notes:
 - Record any unusual events or items.
9. Casing/Rebar Data:
 - The rebar cage fabrication will normally be performed on-site. Observe the lifting to make sure deformation or damage does not occur (especially to CSL tubes). Check that the correct cage is being used. Check reinforcing steel diagram against the actual cage to be sure cage is correct. When the cage is being placed, observe the spacing to assure the cage is set to the proper elevation.



**DRILLED SHAFT CONCRETE PLACEMENT LOG (REV 06-03-02)
SAMPLE 1 Construction Casing**

Project Name	Replace Bridge over Cooper Creek along US-322	Page	5	of	6
File No.	4.995	Bent No.			3
Contractor	Drilled Shaft, Inc.	Shaft No.			3
Completed By Contractor	DS Foreman - John Q. Doe	Date	06/05/02	Station	508 + 36
Reviewed By SCDOT	Inspector - John Smith	Date	06/05/02	Offset	24 FT. Right

Placement Method	<input type="checkbox"/>	Tremie	Volume in Pump Truck	#	ID	Total Length	Volume	
	<input checked="" type="checkbox"/>	Pumped	Pump Truck Lines (6" x 10')	17	6"	170'	1.2 CY	
De-airing Method	<input type="checkbox"/>	Relief Valve	Pump Truck				0.2 CY	
	<input checked="" type="checkbox"/>	Plug						
Total Volume in Lines + Pump Truck							$\Sigma =$	1.4 CY
Reference Elev.	101.0 msl							
Shaft Top Elev.	101.0 msl							
Top of Rock Elev.	49.0 msl							
Shaft Bottom Elev.	39.0 msl							
	Time First Truck Batched: 9:10 am							
	Depth of Water Per Hr. Inside Shaft (Dry Hole Check): NA - Slurry used.							
	Rebar Cage Top Elev. At Start - 108.0 msl At Finish - 108.0 msl							

Truck No.	Concrete Volume	Arrival Time	Start Time	Finish Time	Tremie/ Pump Lines Total Length	Depth To Concrete from Casing Top	Notes
17	9.0 CY	9:20 am	9:25 am	9:40 am	160 FT	41.0 FT	Removed 10' of pump line.
22	9.0 CY	9:30 am	9:45 am	10:00 am	160 FT	21.7 FT	Removed 20' of pump line.
8	9.0 CY	9:40 am	10:05 am	10:20 am	130 FT	2.4 FT	Removed 20' of pump line.
17	4.0 CY	10:30 am	10:35 am	10:50 am	120 FT	0	Waste 2.0 CY (Removing pump lines and overflow.)

31.0 CY Concrete Volume Delivered	Total Placement Time (Temp. Casing Removed) 100 Min.
-----------------------------------	--

	OD	Top Elev.	Bot. Elev.	Start	Finish	Rebar Cage Centered*	YES	NO
T Casing Removal**	NA					Rebar Cage Re-centered	X	

Notes * If no, then re-center rebar cage. ** If unable to remove temporary casing, then call Bridge Construction Office.



DRILLED SHAFT CONCRETE PLACEMENT LOG (REV 06-03-02)
SAMPLE 2 Temporary Casing

Project Name	Replace Bridge over Cooper Creek along US-322		Page	5	of	6
File No.	4.995		Bent No.	6		
Contractor	Drilled Shaft, Inc.		Shaft No.	3		
Completed By Contractor	DS Foreman - John Q. Doe	Date	06/05/02	Station	508 + 36	
Reviewed By SCDOT	Inspector - Jane Smith	Date	06/05/02	Offset	24 FT. Right	

Placement Method	<input type="checkbox"/> Tremie	Volume in Pump Truck	#	ID	Total Length	Volume
	<input checked="" type="checkbox"/> Pumped	Pump Truck Lines (6" x 10')	17	6"	170'	1.2 CY
De-airing Method	<input type="checkbox"/> Relief Valve	Pump Truck				0.2 CY
	<input checked="" type="checkbox"/> Plug					
Total Volume in Lines + Pump Truck						Σ = 1.4 CY
Reference Elev.	101.0 msl		Time First Truck Batched: 9:10 am			
Shaft Top Elev.	100.0 msl		Depth of Water Per Hr. Inside Shaft (Dry Hole Check): NA - Slurry used.			
Top of Rock Elev.	49.0 msl		Rebar Cage Top Elev. At Start - 108.0 msl At Finish - 108.0 msl			
Shaft Bottom Elev.	39.0 msl					

Truck No.	Concrete Volume	Arrival Time	Start Time	Finish Time	Tremie/ Pump Lines Total Length	Depth To Concrete from Casing Top	Notes
17	9.0 CY	9:20 am	9:25 am	9:40 am	160 FT	41.0 FT	Removed 10' of pump line.
22	9.0 CY	9:30 am	9:45 am	10:00 am	160 FT	21.7 FT	Removed 20' of pump line.
8	9.0 CY	9:40 am	10:05 am	10:20 am	130 FT	2.4 FT	Removed 20' of pump line.
17	4.0 CY	10:30 am	10:35 am	10:50 am	120 FT	0	Waste 2.0 CY (Removed the temporary casing, pump lines and concrete overflow.)

31.0 CY Concrete Volume Delivered Total Placement Time (Temp. Casing Removed) 100 Min.

	OD	Top Elev.	Bot. Elev.	Start	Finish	Rebar Cage Centered*	YES	NO
T Casing Removal**	48"	101.0 msl	85.0 msl	10:25 am	10:35 am	Rebar Cage Re-centered		X

Notes * If no, then re-center rebar cage. ** If unable to remove temporary casing, then call Bridge Construction Office.



DRILLED SHAFT CONCRETE VOLUMES LOG (REV 06-03-02)

Project Name _____	Page <u>6</u> of <u>6</u>	
File No. _____	Bent No. _____	
Contractor _____	Shaft No. _____	
Completed By Contractor <u>DS Foreman -</u>	Date <u> / /</u>	Station _____
Reviewed By SCDOT <u>Inspector -</u>	Date <u> / /</u>	Offset _____

Concreting Curve

Depth
(ft)

Concrete Volume Placed (cy)

Volume Delivered	VD	_____ cy
Volume In Pump Truck + Lines	VPTL	_____ cy
Volume of CSL Tubes	VCSLT	_____ cy
Wastage	VW	_____ cy
Volume Placed	VP	_____ cy
= VD-VPTL-VCSLT-VW =		
Theoretical Volume	VTh	_____ cy
Over Pour (VP-VTh \geq 1.00)	OP	_____ cy
Under Pour (VP-VTh $<$ 1.00)	UP	_____ cy

HOW TO COMPLETE THE DRILLED SHAFT CONCRETE VOLUMES LOG



DRILLED SHAFT CONCRETE VOLUMES LOG

Project Name _____	1	Page _____ of _____
Contract No. _____		Pier No. _____
Contractor _____		Shaft No. _____
Inspected By _____		Date / / Station _____
Approved By _____		Date / / Office _____

Concrete Curve			
Top of Shaft			
Depth (ft)	2	Trouble Territory!	Theoretical Line
Bottom of Shaft			
Concrete Volume Placed (cy)			

Volume Delivered	VD	_____	cy
Volume in Lenses	VL	_____	cy
Volume of CSL Tubing	Vr	_____	cy
Wastage	Wt	_____	cy
Volume Placed	VP	_____	cy
= VD-VL-Vr-Wt =	VP	_____	cy
Theoretical Volume	Vth	_____	cy
Difference (VP-Vth)	DP	_____	cy

Fill in every blank on the form. If it does not apply put an "N/A" or a long dash.

Use pencil – but never erase. If you need to change something, strike a single line through the item and insert the correct information above it. If there is insufficient room to make a note, footnote the item and go to the bottom of the page, or use a separate page.

1.	Heading:	-Fill in <u>before</u> drilling starts. -Be sure to print your name and the start date of drilling. -The Project Resident Engineer or designated representative will sign approval line.
2.	Concrete curve:	-compute Theoretical Volume of Concrete based on shaft size: $V_{th} = (\pi d^2 / 4) \times L$ -locate points based on known cubic yards of concrete placed at measured "bottom" depth. -must be plotted during concrete placement.

Note: Plotted line should closely parallel Theoretical line.
There is a problem if:

- a point plots way above or below the Theoretical line and/or
- there is a significant rise or fall in an otherwise straight line (change in slope of line).



DRILLED SHAFT CONCRETE VOLUMES LOG (REV 06-03-02)

SAMPLE 1 Construction Casing

Project Name	Replace Bridge over Cooper Creek along US-322	Page	6	of	6
File No.	4.995	Bent No.	3		
Contractor	Drilled Shaft, Inc.	Shaft No.	3		
Completed By Contractor	DS Foreman - John Q. Doe	Date	06/05/02	Station	508 + 36
Reviewed By SCDOT	Inspector - John Smith	Date	06/05/02	Offset	24 FT. Right

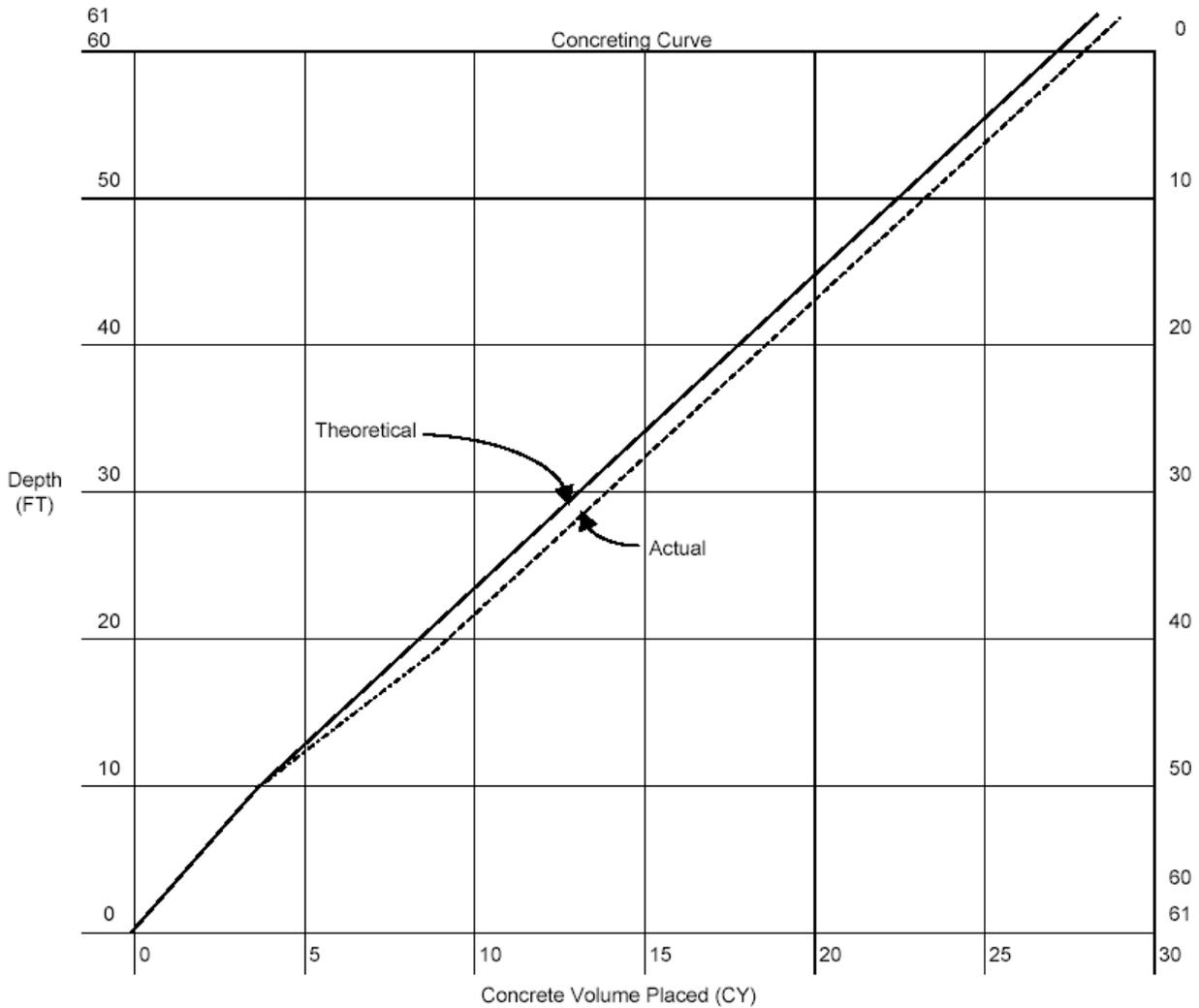

Volume Delivered	VD	31.0	CY
Volume In Pump Truck + Lines	VPTL	-1.4	CY - Volume left in pump truck and lines.
Volume of CSL Tubes	VCSLT	+0.2	CY
Wastage	VW	-2.0	CY - Removed pump lines and concrete overflow.
Volume Placed	VP	27.8	CY
= VD-VPTL-VCSLT-VW =			
Theoretical Volume	VTh	27.2	CY
Over Pour (VP-VTh => 1.00)	OP	0.6	CY
Under Pour (VP-VTh < 1.00)	UP	NA	CY



DRILLED SHAFT CONCRETE VOLUMES LOG (REV 06-03-02)
SAMPLE 2 Temporary Casing

Project Name	Replace Bridge over Cooper Creek along US-322	Page	6	of	6
File No.	4.995	Bent No.	6		
Contractor	Drilled Shaft, Inc.	Shaft No.	3		
Completed By Contractor	DS Foreman - John Q. Doe	Date	06/05/02	Station	508 + 36
Reviewed By SCDOT	Inspector - Jane Smith	Date	06/05/02	Offset	24 FT. Right

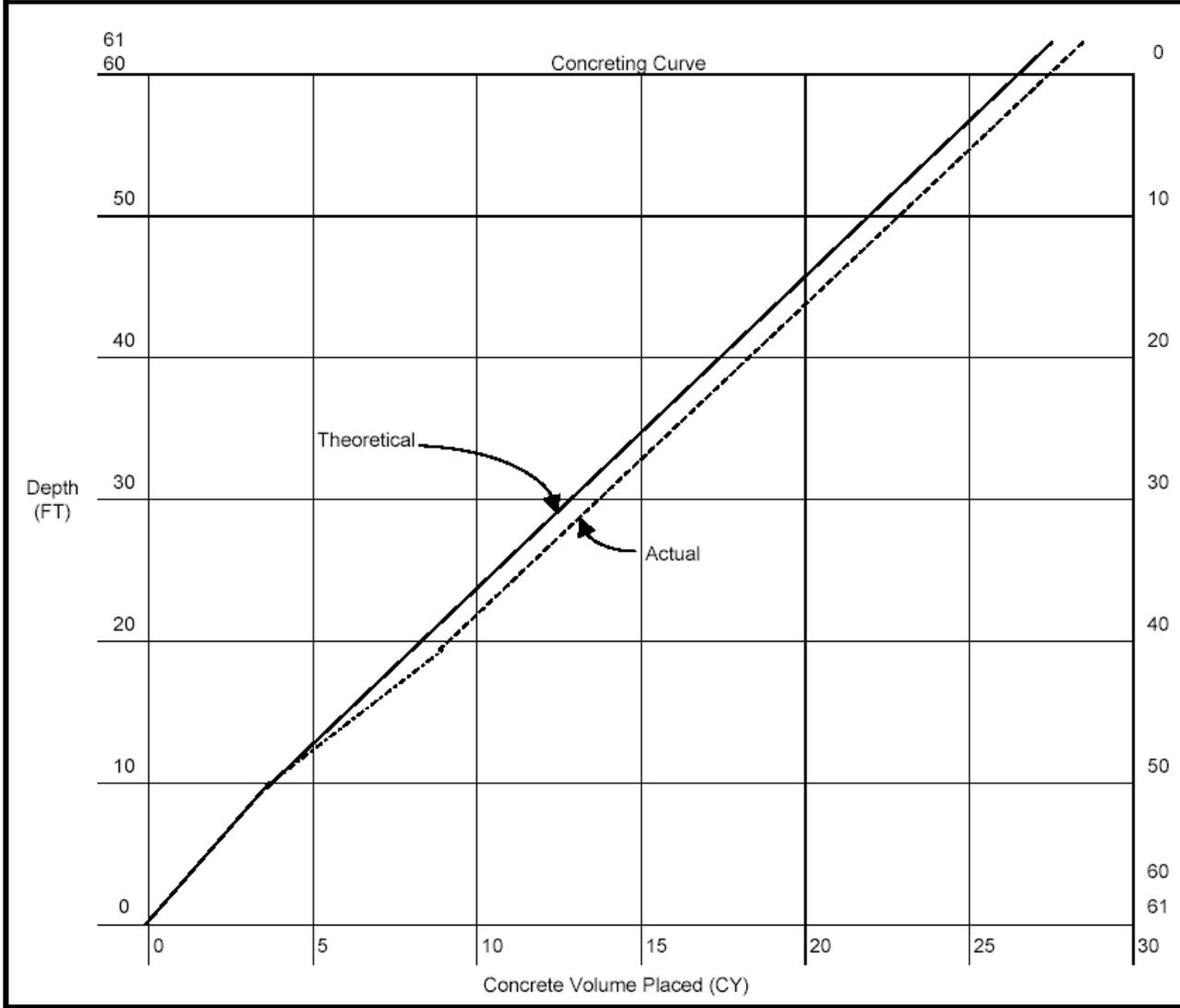

Volume Delivered	VD	31.0	CY
Volume In Pump Truck + Lines	VPTL	-1.4	CY - Volume left in pump truck and lines.
Volume of CSL Tubes	VCSLT	+0.2	CY
Wastage	VW	-2.0	CY - Removed pump lines and concrete overflow.
Volume Placed	VP	27.8	CY
= VD-VPTL-VCSLT-VW =			
Theoretical Volume	VTh	27.3	CY
Over Pour (VP-VTh => 1.00)	OP	0.5	CY
Under Pour (VP-VTh < 1.00)	UP	NA	CY

EXHIBIT 6a

TRAFFIC SIGNAL SUPPLEMENTAL SPECIFICATIONS AND FORMS

SCDOT TRAFFIC SIGNALS

SUPPLEMENTAL SPECIFICATIONS

Revised
7/17/2013

Traffic Signals Supplemental Specifications

Table of Contents

		Revision Date
103.1	MOBILIZATION	7/17/2013
103.2	MOBILIZATION OF MATERIAL	7/17/2013
675.1	ELECTRICAL CONDUIT	7/17/2013
676.1	FIBER OPTIC TRAINING	7/17/2013
676.2	FIBER OPTIC TEST EQUIPMENT	7/17/2013
677.1	ELECTRICAL CABLE	7/17/2013
677.2	COMMUNICATION CABLE	7/17/2013
677.3	FIBER OPTIC CABLE	7/17/2013
677.4	FIBER INTERCONNECT CENTER	7/17/2013
677.5	FIBER OPTIC MODEM	7/17/2013
677.6	FACTORY TERMINATED PATCH PANEL	7/17/2013
677.7	SPREAD SPECTRUM RADIO ASSEMBLY	7/17/2013
678.1	DETECTOR LOOP	7/17/2013
680.1	ELECTRIC SERVICE	7/17/2013
680.2	SPLICE BOX/JUNCTION BOX	7/17/2013
682.1	WOOD POLE	7/17/2013
682.2	BACK-GUY	7/17/2013
682.3	STEEL CABLE	7/17/2013
682.4	PEDESTRIAN POLE AND BASE	7/17/2013
686.1	LED MODULES AND/OR POLYCARBONATE VEHICLE SIGNAL HEAD AND/OR BACKPLATE	7/17/2013
686.2	OPTICALLY PROGRAMMABLE VEHICLE SIGNAL HEAD	7/17/2013
686.3	PEDESTRIAN SIGNAL HEAD	7/17/2013
686.4	PEDESTRIAN PUSH BUTTON STATION ASSEMBLY WITH SIGN	7/17/2013
686.5	SYMBOLIC LED BLANKOUT SIGN	7/17/2013
688.1	REMOVAL, SALVAGE AND DISPOSAL OF EQUIPMENT AND MATERIALS	7/17/2013
688.2	TEMPORARY ADJUSTMENT OF TRAFFIC SIGNAL EQUIPMENT AND TIMINGS	7/17/2013
688.3	VIDEO DETECTION - LOOP EMULATION SYSTEM	7/17/2013
688.5	STEEL STRAIN POLE AND FOUNDATION	7/17/2013
688.6	CONCRETE STRAIN POLE	7/17/2013
688.7	CONTROLLER AND 332/336 CABINET	7/17/2013
688.8	REMOTE SPLICE/FLASHER CABINET	7/17/2013
688.9	SOLAR POWERED FLASHER ASSEMBLY	7/17/2013
689.1	WORKING CREW WITH EQUIPMENT	7/17/2013
689.2	SYSTEM INTEGRATION AND TESTING	7/17/2013
689.3	TRAFFIC SIGNAL SYSTEM TRAINING	7/17/2013
690.1	STEEL POLE WITH MAST ARM	7/17/2013

SUPPLEMENTAL SPECIFICATION REVISIONS

Date	Specification	Details of Revision
7/17/2013	103.1	Added Pay Item Notes
7/17/2013	103.2	Revised Pay Items , Added Pay Item Notes
7/17/2013	675.1	Revised Specification, Added Pay Item Notes, Added Pay Item
7/17/2013	676.1	Added Pay Item Notes
7/17/2013	676.2	Added Pay Item Notes
7/17/2013	677.1	Added Pay Item Notes
7/17/2013	677.2	Revised Pay Item Numbers , Added Pay Item Notes
7/17/2013	677.3	Revised Pay Item Number , Added Pay Item Notes
7/17/2013	677.4	Added Pay Item Notes
7/17/2013	677.5	Added Pay Item Notes
7/17/2013	677.6	Added Pay Item Notes
7/17/2013	677.7	Added Pay Item Notes
7/17/2013	678.1	Added Pay Item Notes
7/17/2013	680.1	Added Pay Item Notes
7/17/2013	680.2	Added Pay Item Notes
7/17/2013	682.1	Revised Ground Rod Dimensions , Added Pay Item Notes
7/17/2013	682.2	Added Pay Item Notes
7/17/2013	682.3	Added Pay Item Notes
7/17/2013	682.4	Added Pay Item Notes
7/17/2013	686.1	Added Pay Items, Added Pay Item Notes
7/17/2013	686.2	Added Pay Item Notes
7/17/2013	686.3	Revised Pay Item Numbers , Added Pay Item Notes
7/17/2013	686.4	Added Pay Item Notes
7/17/2013	686.8	Added Pay Item Notes
7/17/2013	688.1	Added Pay Item Notes
7/17/2013	688.2	Added Pay Item Notes
7/17/2013	688.3	Added Pay Item Notes
7/17/2013	688.5	Revised Class 5000 Concrete, Added Pay Items, Added Pay Item Notes
7/17/2013	688.6	Added Pay Item Notes
7/17/2013	688.7	Revised Class 3000 Concrete, Added Pay Items , Added Pay Item Notes
7/17/2013	688.8	Added Pay Item Notes
7/17/2013	688.9	Added Pay Item Notes
7/17/2013	689.1	New Specification
7/17/2013	689.2	Added Pay Item Notes
7/17/2013	689.3	Added Pay Item Notes
7/17/2013	690.1	Added Pay Items , Added Pay Item Notes

103.1 MOBILIZATION

1.1 Description

This item shall consist of performing preparatory operations, including moving personnel and equipment to the project site; paying bonds and insurance premiums, establishing contractor's offices, buildings and other facilities necessary for work on the project and for all other work and operations which must be performed or costs incurred prior to beginning work on the project.

1.2 Construction

All work performed in providing the facilities and services, shall be done in a safe and workman-like manner.

1.3 Measurement

Mobilization will be paid for at the contract Line Item as described in special provisions. This price shall include demobilization.

1.4 Payment

Payment for mobilization will be made per work order, for each project as follows:

1031000	MOBILIZATION	LS
1031010	MOBILIZATION	EA

Full payment for mobilization will be made in accordance with the provisions set forth above, which shall be full compensation for organizing and moving all forces, supplies, equipment and incidentals to the project site, regardless of the number of times such moves are made per work order.

Pay Item Notes

Item 1031000 is most commonly used when full signal plans are provided.

Item 1031010 is generally used in work order contracts as 1 each per work order.

This specification is not limited to these pay items. Other pay items may be applicable.

103.2 MOBILIZATION OF MATERIAL

1.1 Description

This item shall consist of performing preparatory operations, specifically moving materials to the project site necessary for work on the project and for all other work and operations which must be performed or costs incurred prior to beginning work on the project. Materials shall include, but not limited to, concrete strain poles, steel strain poles, wood strain poles, cabinets and other incidental items. Some materials will be made available for pickup at the SCDOT Supply Depot, 1418 Shop Rd, Columbia, SC.

1.2 Construction

All work performed while moving materials shall be done in a safe and workmanlike manner.

1.3 Measurement

Mobilization of Material will be paid for at the contract Line Item price as described in special provisions. This price shall include demobilization.

1.4 Payment

Payment for Mobilization of Material will be made per work order, for each project as follows:

9610021	MOBILIZATION OF MATERIAL PER WORK ORDER, 1-100 MILES FROM LOCATION TO WORKSITE	EA
9610022	MOBILIZATION OF MATERIAL PER WORK ORDER, 101-250 MILES FROM LOCATION TO WORKSITE	EA
9610023	MOBILIZATION OF MATERIAL PER WORK ORDER, 250+ MILES FROM LOCATION TO WORKSITE	EA

Full payment for mobilization of material will be made in accordance with the description in the special provisions; which shall be full compensation moving materials and incidentals to the project site, regardless of the number of times such moves are made.

Pay Item Notes

This specification is not limited to these pay items. Other pay items may be applicable.

675.1 ELECTRICAL CONDUIT

1.1 Description

This work shall consist of installing and/or furnishing Electrical Conduit and fittings of the types and sizes specified herein, at locations shown on the Plans, or as established by the ENGINEER in accordance with these Specifications. All materials will be subject to inspection for condition by the ENGINEER, just prior to incorporation into the work.

1.2 Materials

1.2.1 Steel Conduit

Steel Electrical Conduit shall be rigid, heavy-wall, galvanized steel, meeting the requirements of Federal Specification WW-C-581, and American Standards Association Specifications USAS C-80.1-1966.

1.2.2 PVC Conduit (Typically used by SCDOT)

Plastic conduit shall be sunlight resistant Polyvinyl chloride (PVC), SCHEDULE 80, meeting the requirements of National Electrical Manufacturing Association (NEMA) Specification TC-2 and Underwriter Laboratory (UL) standards UL-514; and/or ASTM D-1784. Fittings shall meet NEMA TC-3 and UL-514.

1.2.3 HDPE Rolled Conduit – (High Density Polyethylene)

Underground cables can be installed in rolled conduit, directional bored (Trenchless) as an acceptable alternative. This conduit shall be a minimum of SCHEDULE 80. It shall be buried at a minimum of 18 inch depth.

1.2.4 Flexible Weather-Tight Steel Conduit

Weather-Tight/liquid-tight flexible steel electrical conduit shall be single strip, helically wound, interlocking galvanized steel. It shall be made liquid-tight by an extruded polyvinyl chloride jacket; and shall meet the requirements of UL-360.

1.2.5 Fittings

All conduit bodies, 90° bends, weatherheads, elbows, nipples, couplings, and other hardware shall be made of the same material and quality as the conduit run and shall be incidental to conduit installation.

1.2.6 Conduit Junction Box

The Conduit Junction Box (for some roadside detector loop installations), shall be a non-metallic PVC molded junction box with a weather tight screw-down cover, of nominal size 6"W x 6"L x 4"D. It shall be incidental to conduit installation. Unless shown mounted on a pole, it shall be installed in the dirt, at the depth of the conduit run, and covered with earth.

1.2.7 Ground Bushings

Grounding Bushings shall be threaded, made of malleable iron, galvanized steel, or brass; and shall have an insulating plastic insert, and lay-in lugs to hold No. 6 AWG copper wire.

1.2.8 Pulling Line

The Pulling Line shall be Polypropylene Rope, having a minimum tensile strength of 240 pounds, which SHALL BE PULLED INTO ALL UNDERGROUND CONDUIT RUNS, AND SHALL REMAIN THEREIN FOR FUTURE USE.

1.2.9 Warning Tape

Underground Warning Tape shall be Heavy duty B-720 polyethylene, 0.89 mm (3.5 mils) thick, by 76 mm (3 in) wide, with APWA color RED, for electric lines. The Tape shall be PLACED ABOVE ALL TRENCHED CONDUIT RUNS, just before the final back-fill.

1.2.10 Tracer Wire

When conduit is used exclusively for Fiber Optic communication cable, a minimum 14 Ga. Tracer Wire shall be installed inside conduit.

1.2.11 Concrete

Concrete used for patching pavement shall be DOT STANDARD SPECIFICATION CLASS X according to Sections 701,702,703, and 704.

1.2.12 Bituminous Concrete

Bituminous Concrete for patching pavement shall be DOT STANDARD SPECIFICATIONS, Section 400 and 403.

1.3 Construction

1.3.1 General

Conduit shall be installed as either a Riser, or be Trenched, or Directional Bored.

1.3.2 Depth

Unless shown otherwise, conduits shall be placed a minimum depth of 18 inches below surface grade, and shall slope at a minimum rate of 6 inches per 100 feet of length, to a splice box/junction box hole or drain. All conduit runs shall be cleaned and swabbed before cables are installed. In poles, cabinets, and buildings, DUCT-SEAL shall be used to effectively seal the opening.

1.3.3 Direction

Changes in direction of conduit shall be accomplished by the use of standard bends, elbows, or by bending the steel conduit. Steel conduit, if bent, shall have a uniform radius which will fit the location, with a minimum radius of six (6) times the internal diameter of the pipe. Sharp kinks in the conduit or the substitution of unlike materials will not be permitted.

1.3.4 Fittings

Standard manufactured conduit bodies, condulets, weatherheads, elbows, nipples, tees, reducers, bends, couplings, unions, etc., of the same materials and treatment as the straight conduit, shall be used as required throughout the conduit line. All fittings shall be tightly connected to the conduit. A SOLVENT-WELD CEMENT shall be used for fitting connections with PVC conduit. Where steel conduit mates PVC, an adapter coupling shall be used and sealed waterproof.

1.3.5 Cutting

Nipples shall be used to eliminate cutting and threading where short lengths of conduit are required. Where it is necessary to cut and thread steel conduit, no exposed threads will be permitted. All conduit fittings shall be free from burrs and rough places; and all cut conduits shall be reamed before fittings and cables are installed. All conduit runs ending in a junction box, hand box, or other approved junction point, shall be provided with a bushing to protect the cable from abrasion. Conduit being placed for future use shall be capped.

1.3.6 Location

Where conduit passes under a curb, an 'X' shall be cut in the curb, over the conduit. Where there is no curb, a stake shall be driven in the ground at the end of the conduit to mark its location. Where conduit is placed in a signal pole foundation for future use, an 'X' shall be cut to indicate the side the conduit enters.

1.3.7 Risers

Conduit Risers shall be attached to wood poles; or where specified, to the outside of steel poles. Stainless Steel bands shall be used for steel poles. Conduit clamps/straps and galvanized screws shall be used on wood poles. Attachment shall be in accordance with the Design Details, the Standards, or the Plans. Each Riser shall be furnished with a weatherhead, which shall not be measured.

1.3.8 Trenching (Non-Paved Surface)

Trenches shall be excavated to such depth as necessary to provide 18 inches minimum cover over the conduit. Cinders, broken concrete, or other hard abrasive materials will not be permitted in the back-filling. The trench shall be free of such materials before the conduit is placed. No conduit shall be placed prior to inspection by the ENGINEER. Back-Fill shall be compacted, and the surface restored.

1.3.9 Trenching (In Paved Surface)

Trenches across driveways or streets shall be cleanly saw cut about 6 inches wide. The conduit shall be placed and the back-fill shall be compacted, and the patch shall be of like material and thickness as was removed. NO additional payment shall be made for the bituminous or concrete patching material, unless a pay item has been established for such.

1.3.10 Bored and Jack (Pushing)

Where shown on the Plans as Bored or Jacked, certain steel conduit to be placed under existing roadways, driveways, sidewalks, or other paved surfaces, shall be BORED AND JACKED. Such conduit shall be placed by jacking, boring, pushing, or other means approved by the ENGINEER, without cutting or removing pavement.

1.3.11 Trenchless (Directional Bored)

When the signal design anticipates that HIGH-ACCURACY DIRECTIONAL BORING techniques will be used, and the conduit pulled back through the bore, then a pay item will be established for: **SCHEDULE 80 PVC CONDUIT (DIRECTIONAL BORED)**. The Directional Boring method shall be approved by the ENGINEER, and shall in no way crumple or damage the conduit. An acceptable alternative material can be **SCHEDULE 80 HDPE CONDUIT (TRENCHLESS)**.

1.3.12 Placed Before Pouring

Where shown on the Plans, PVC conduit, with Flexible Weather Tight conduit, shall be placed in roadways or structures, prior to pouring the concrete. Typical usage would be a bridge deck. The conduit shall be firmly attached to the bottom reinforcement bar mat, or to the bottom wire-mat, using plastic tie-wraps every 2 feet. At expansion joints, 4 feet (typical) of Flexible Weather Tight steel conduit shall be used to accommodate movement. These shall be installed to NEC standards for concrete structural installations and usage, including any recommended lubricants and sleeves. All conduit ends etc. shall be plugged to prevent concrete penetration. When used on a bridge, there will usually be splice-box(es) near the center line, and the conduit will terminate in hand-boxes at each end.

1.3.13 Restoration

The Contractor shall restore all cuts, trenches, and openings to the original condition. Grass surfaces shall be replaced with pre-grown, cut turf (sod), in existing lawns. Other dirt areas shall be raked, seeded, and fertilized. While care should have been used to avoid them, any damaged trees and shrubs shall be replaced (if directed by the ENGINEER).

1.4 Measurement

Electrical Conduit will be measured by LINEAR FEET, for the type, size, and method of installation specified, along the center line of the conduit from end to end, including trenched, risers, and bored-and-jacked.

Conduit bends, conduit bodies, (condulets), 90° bends, elbows, conduit junction boxes for detector loops, miscellaneous fittings, couplings, weatherheads, adapters, bushings, locknuts, and other items shall be incidental to conduit installation and shall NOT be measured.

Unless otherwise specified, trenching, back-filling, and patching will NOT be measured for payment

1.5 Payment

Accepted quantities of electrical conduit, measured as provided above, will be paid for at the Contract unit price bid for:

For conduit either Trenched or Riser:

6750005	FURNISH & INSTALL 1.0" GALVANIZED RIGID CONDUIT	LF
6750010	FURNISH & INSTALL 1.5" GALVANIZED RIGID CONDUIT	LF
6750015	FURNISH & INSTALL 2.0" GALVANIZED RIGID CONDUIT	LF
6750020	FURNISH & INSTALL 2.5" GALVANIZED RIGID CONDUIT	LF
6750025	FURNISH & INSTALL 3.0" GALVANIZED RIGID CONDUIT	LF
6750030	FURNISH & INSTALL 3.5" GALVANIZED RIGID CONDUIT	LF
6750035	FURNISH & INSTALL 4.0" GALVANIZED RIGID CONDUIT	LF
6750040	FURNISH & INSTALL 5.0" GALVANIZED RIGID CONDUIT	LF
6750045	FURNISH & INSTALL 6.0" GALVANIZED RIGID CONDUIT	LF
*6750275	FURNISH & INSTALL 1.0" SCHEDULE 80 PVC CONDUIT	LF
*6750278	FURNISH & INSTALL 2.0" SCHEDULE 80 PVC CONDUIT	LF
*675027C	FURNISH & INSTALL 3.0" SCHEDULE 80 PVC CONDUIT	LF
675027G	FURNISH & INSTALL 4.0" SCHEDULE 80 PVC CONDUIT	LF
675027K	FURNISH & INSTALL 5.0" SCHEDULE 80 PVC CONDUIT	LF
675027O	FURNISH & INSTALL 6.0" SCHEDULE 80 PVC CONDUIT	LF
6750181	FURNISH & INSTALL 1.0" ALUMINUM CONDUIT	LF

For bored and jacked:

6750075	FURNISH & INSTALL 0.75" GALVANIZED RIGID CONDUIT (BORED AND JACKED)	LF
6750078	FURNISH & INSTALL 1.0" GALVANIZED RIGID CONDUIT (BORED AND JACKED)	LF
6750080	FURNISH & INSTALL 1.25" GALVANIZED RIGID CONDUIT (BORED AND JACKED)	LF
6750082	FURNISH & INSTALL 1.5" GALVANIZED RIGID CONDUIT (BORED AND JACKED)	LF
6750085	FURNISH & INSTALL 2.0" GALVANIZED RIGID CONDUIT (BORED AND JACKED)	LF
6750088	FURNISH & INSTALL 2.5" GALVANIZED RIGID CONDUIT (BORED AND JACKED)	LF
6750090	FURNISH & INSTALL 3.0" GALVANIZED RIGID CONDUIT (BORED AND JACKED)	LF
6750093	FURNISH & INSTALL 4.0" GALVANIZED RIGID CONDUIT (BORED AND JACKED)	LF
6750096	FURNISH & INSTALL 5.0" GALVANIZED RIGID CONDUIT (BORED AND JACKED)	LF
6750099	FURNISH & INSTALL 6.0" GALVANIZED RIGID CONDUIT (BORED AND JACKED)	LF
6750281	FURNISH & INSTALL 5.0" SCHEDULE 80 PVC CONDUIT(BORED & JACKED)	LF
6750284	FURNISH & INSTALL 6.0" SCHEDULE 80 PVC CONDUIT(BORED & JACKED)	LF

For high accuracy directional boring:

675027S	FURNISH & INSTALL 2.0" SCHEDULE 80 PVC CONDUIT (DIRECTIONAL BORED)	LF
675027V	FURNISH & INSTALL 3.0" SCHEDULE 80 PVC CONDUIT(DIRECTIONAL BORED)	LF
675027Y	FURNISH & INSTALL 4.0" SCHEDULE 80 PVC CONDUIT(DIRECTIONAL BORED)	LF
6760050	FURNISH & INSTALL 1" SCHEDULE 80 HDPE CONDUIT (TRENCHLESS)	LF
6760060	FURNISH & INSTALL 2" SCHEDULE 80 HDPE CONDUIT (TRENCHLESS)	LF
6760070	FURNISH & INSTALL 3" SCHEDULE 80 HDPE CONDUIT (TRENCHLESS)	LF
6760080	FURNISH & INSTALL 4" SCHEDULE 80 HDPE CONDUIT (TRENCHLESS)	LF

For flexibility:

6750175	FURNISH & INSTALL 1.0" FLEXIBLE GALVANIZED STEEL CONDUIT - WEATHER TIGHT	LF
6750177	FURNISH & INSTALL 1.5" FLEXIBLE GALVANIZED STEEL CONDUIT - WEATHER TIGHT	LF
6750179	FURNISH & INSTALL 2.0" FLEXIBLE GALVANIZED STEEL CONDUIT - WEATHER TIGHT	LF
675017B	FURNISH & INSTALL 2.5" FLEXIBLE GALVANIZED STEEL CONDUIT - WEATHER TIGHT	LF
675017D	FURNISH & INSTALL 3.0" FLEXIBLE GALVANIZED STEEL CONDUIT - WEATHER TIGHT	LF
675017F	FURNISH & INSTALL 3.5" FLEXIBLE GALVANIZED STEEL CONDUIT - WEATHER TIGHT	LF
675017H	FURNISH & INSTALL 4.0" FLEXIBLE GALVANIZED STEEL CONDUIT - WEATHER TIGHT	LF
675017L	FURNISH & INSTALL 5.0" FLEXIBLE GALVANIZED STEEL CONDUIT - WEATHER TIGHT	LF
675017P	FURNISH & INSTALL 6.0" FLEXIBLE GALVANIZED STEEL CONDUIT - WEATHER TIGHT	LF

which shall be full compensation for furnishing and placing all materials, fittings, equipment, labor, and incidentals necessary to complete the work as specified.

Pay Item Notes

* Typically used by SCDOT

This specification is not limited to these pay items. Other pay items may be applicable.

676.1 FIBER OPTIC TRAINING

1.1 Description

The CONTRACTOR shall provide both formal classroom and "in-field" operations and maintenance training for up to fifteen (15) designated CITY and/or SCDOT personnel on the fiber optic cable system and its components. All training shall be coordinated by the CONTRACTOR at a time mutually agreed upon by the RCE, the CITY, SCDOT, and the CONTRACTOR. The classroom training session shall be held at SCDOT offices in Columbia. The DEPARTMENT shall make available a conference room where the training will be held.

Classroom training shall be completed prior to the CONTRACTOR beginning installation of the fiber optic cable. Field training shall be held in conjunction with the actual construction of the signal system.

All training material generated for each course shall contain "hand-outs" for each attendee. These hand-outs shall serve not only as subject guidance, but as quick-reference material for future use by the students. All course material, in reproducible form, shall be delivered to the ENGINEER immediately following course completion. If available, the CONTRACTOR shall provide video tapes of the training program.

The schedule for such training shall be submitted for approval by the RCE at least two (2) weeks prior to the proposed starting date.

1.2 Training

1.2.1 Classroom Training

Personnel shall be trained to install, splice, and test fiber optic cable. This training shall be a minimum of 32 hours. The 32 hours of fiber optic training shall be a four (4) day course taught by personnel from the manufacturer of the fiber optic cable for the project. Topics in the course shall include: safety, theory, fiber types, cable placement techniques, fiber optic sheath removal, hardware types, fault location with an optical time domain reflectometer (OTDR), splicing and termination methods and applications, theory and principles of splicing, fusion splicing, mechanical splicing, cable preparation procedures for installing optical connectors, installing ST connectors, mocking up a typical traffic control system, cable system testing and documentation, attenuation test procedures, and overall cable system maintenance. This course shall include lectures, demonstrations and hands-on experience with the equipment. Students shall be given hand-outs to use as guides for field applications.

In addition to the above training, the CONTRACTOR shall assist the CITY and SCDOT in developing regular preventive maintenance plans for the fiber optic communication plant (which includes the fiber optic cable, the fiber interconnect centers and the fiber optic modems).

1.2.2 Field Training

Field training shall be provided to the CITY and SCDOT personnel assigned to the project. This training shall consist of the following as a minimum: eight (8) hours of fiber optic communications plant trouble shooting including fault location using an optical power meter/light source and using an Optical Time Domain Reflectometer (OTDR) cable tester, four (4) hours of field splicing (which shall include re-entrant rotary mechanical splicing and fusion splicing techniques), and four (4) hours of training on the

installation, maintenance, and replacement of fiber interconnect centers and fiber optic modems. This training should be done in conjunction with the actual installation of the system, and should be both observatory and "hands-on" (whenever possible).

1.2.3 Course Outlines and Workbooks

For both types of training, the CONTRACTOR shall submit to the RCE for approval four (4) copies of all proposed training material, which shall include course curriculums, draft manuals, and resumes of instructors. Such submittal shall be made at least four (4) weeks prior to the scheduled starting date. The RCE shall notify the CONTRACTOR within five (5) days if the proposed training material is acceptable. For the classroom training, the CONTRACTOR shall also provide for each participant a course workbook, which shall be provided in loose-leaf format in a three (3) ring binder.

1.3 Measurement

Fiber Optic Training will not be measured, but shall be paid as a Lump Sum item.

1.4 Payment

Fiber Optic Training shall be paid at the Contract price bid for

6886030	TRAINING BEING FIBER OPTIC	LS
---------	----------------------------	----

which shall be full compensation for the training as specified.

Pay Item Notes

This specification is not limited to these pay items. Other pay items may be applicable.

676.2 FIBER OPTIC TEST EQUIPMENT

1.1 Description

The CONTRACTOR shall furnish to SCDOT the following test equipment for the Department's use in maintaining the fiber optic cable plant:

Optical Power Meter
Optical Light Source
Emergency Restoration Tool Kit

The equipment furnished by the CONTRACTOR shall be new and in the manufacturer's packaging when given to SCDOT. The CONTRACTOR shall note that sections of the special provisions for testing of the fiber optic network state that an Optical Time Domain Reflectometer (OTDR) shall be used for testing purposes. The OTDR used for testing purposes shall be furnished by the CONTRACTOR.

1.2 Materials

1.2.1 Optical Power Meter

The CONTRACTOR shall furnish a hand-held optical power meter. The power meter shall test 850, 1300, and 1500 nm wavelengths. It shall measure optical power through fibers, check end electronics and power loss through the fiber. The meter shall have a rechargeable NI-CAD battery, AC adapter/charger, a backlit LCD display, be auto ranging and provide measurements in dBm and watts. The meter shall be capable of being used continuously for nine (9) hours without recharging and shall be furnished with an instruction manual. The meter shall have the capability of accepting interchangeable connector adapters and shall be furnished with a type ST compatible adapter. The meter shall also be furnished with an ST compatible bare fiber adapter. The optical power meter shall be from the same manufacturer as the optical light source. The meter shall be warranted by the manufacturer for at least one (1) year. The meter shall be a Siecormodel OM-100F or approved equivalent.

1.2.2 Optical Light Source

The CONTRACTOR shall furnish a hand-held laser optical light source. The light source shall have a dual laser operating at 1310 and 1550 nm. The light source shall include a low-battery indicator, contain a built-in rechargeable NI-CAD battery and be furnished with an AC adapter/charger.

The optical light source shall be furnished with an ST compatible connector and shall be from the same manufacturer as the optical power meter. The meter shall be warranted by the manufacturer for at least one (1) year. The meter shall be a Siecormodel OS-100 or approved equivalent.

1.2.3 Transit Case

The CONTRACTOR shall furnish a transit case for the storage and transport of the optical meter and optical light source. The transit case shall be approximately 14.0" (L) x 11.0" (W) x 6" (D) and shall be water, crush and dust resistant. The case shall be lined with shock absorbing foam that contains dedicated areas to securely store the power meter and light source. The case shall also include storage area for the battery chargers, a jumper box, and connector adapter box.

1.2.4 Emergency Restoration Kit

The CONTRACTOR shall furnish an emergency restoration tool kit that contains all the necessary implements for the recovery of the single-mode fiber optic system. The kit shall contain as a minimum the following components.

- (1) Fiber Cleaner (score and snap)
- (1) Sheath Removal Tool
- (1) Buffer tube stripping tool
- (1) Crimping Pliers
- (1) Cam Splice Assembly Manual
- (1) Fiber Stripper Procedure
- (6) Cam Splice Assembly Fixture
- (6) Cam Splice No-Adhesive Mechanical Splices

The emergency restoration kit shall be a Siecor Model TKT-009-01 or approved equivalent.

1.3 Measurement

The item "Furnish Fiber Optic Test Equipment" shall not be measured but will be paid as a lump sum item covering all the equipment specified.

1.4 Payment

The item "Furnish Fiber Optic Test Equipment" shall be paid for at the contract price bid for

6770488	FIBER OPTIC TEST EQUIPMENT	LS
---------	----------------------------	----

which shall be full compensation for all the test equipment and for delivery of the equipment to the SCDOT district offices in PROJECT DISTRICT.

Pay Item Notes

This specification is not limited to these pay items. Other pay items may be applicable.

677.1 ELECTRICAL CABLE

1.1 Description

This work shall consist of installing and/or furnishing traffic signal, loop lead-in, pedestrian signal, and pedestrian push button Electrical Cable of the size and type shown on the Plans, or as established by the ENGINEER, in accordance with these Specifications.

1.2 Materials

Acceptable materials can be found on the current SCDOT Qualified Products List. Product Specifications for acceptable materials are located at http://www.scdot.org/doing/publications_Traffic.aspx

1.3 Construction

1.3.1 Field Wiring

All cable runs shall be SPLICE-FREE. All connections shall be made at terminal blocks, or in the controller cabinet.

All field wiring shall be in accordance with applicable Electrical Codes--National, State, and Local. Where required, arranging for PERMITS and/or electrical INSPECTION is the responsibility of the Contractor.

At each splice box, strain pole base, and cabinet, at least 3 feet of cable slack shall be provided. The slack shall be neatly coiled, and bound with a nylon tie.

At the cabinet end, each cable shall be labeled, using nylon cable markers, and indelible pen. The Phase and/or Approach (NB, EB, etc.) shall be shown.

Cabinet connections shall correspond to the COLOR-CODE shown on the TYPICAL WIRE & CABLE USAGE sheet; (green wire to green signal circuit, etc.).

The entire length of cables damaged during installation, shall be replaced, without further cost to the Department.

All electrical cable installed in conduit shall be drawn in place, free from electrical and mechanical injury. When a lubricating agent is needed, a wire pulling compound compatible with the cable insulation shall be used.

Vertical cable runs mounted on the outside of poles shall be installed in conduit of the type shown on the Design Details or in the Standards.

Weather service heads shall be used wherever electrical cable directly enters a strain pole or a vertical conduit run.

Drip loops of at least 8 inches shall be provided at all overhead entrance points such as signal heads, strain poles, or weather heads.

1.3.2 Traffic Signal Wiring

Each cable run shall have the number of conductors indicated in the Standards, the Design Details, the Plans, or the WIRING DIAGRAM. These include the provision of spare conductors. The substitution of additional cables to attain the required number of conductors shall not be permitted.

A separate cable shall be run for each phase or approach. (See TYPICAL WIRE & CABLE USAGE sheet.)

The list below is a guide to general usage--

Signal: Jumpers	4 pair (8 conductor) BLACK
Signal: To Each Approach	4 pair (8 conductor) BLACK

1.3.3 Loop lead-in Wiring

Each cable run shall have the number of conductors indicated in the Standards, the Design Details, the Plans, or the WIRING DIAGRAM. These include the provision of spare conductors. The substitution of additional cables to attain the required number of conductors shall not be permitted.

A separate cable should be run to each corner of the intersection. (See TYPICAL WIRE & CABLE USAGE sheet.)

The list below is a guide to general usage--

Loop: To Each Corner	4 pair (8 conductor) GRAY
Loop Lead-in	2 pair (4 conductor) GRAY

1.3.4 Pedestrian Signal Head Wiring

Each cable run shall have the number of conductors indicated in the Standards, the Design Details, the Plans, or the WIRING DIAGRAM. These include the provision of spare conductors. The substitution of additional cables to attain the required number of conductors shall not be permitted.

A separate cable should be run for each phase or approach. (See TYPICAL WIRE & CABLE USAGE sheet.)

The list below is a guide to general usage--

Pedestrian Signal	2 pair (4 conductor) BLACK
Pedestrian Push Button	2 pair (4 conductor) GRAY
Loop Lead-in	2 pair (4 conductor) GRAY

1.3.5 Push Button Wiring

Each cable run shall have the number of conductors indicated in the Standards, the Design Details, the Plans, or the WIRING DIAGRAM. These include the provision of spare conductors. The substitution of additional cables to attain the required number of conductors shall not be permitted.

A separate cable should be run for each phase or approach. (See TYPICAL WIRE & CABLE USAGE sheet.)

The list below is a guide to general usage--

Pedestrian Push Button 2 pair (4 conductor) GRAY

1.3.6 *Electrical Conduit*

All conduit and elbows shall be installed as described in the appropriate Specification.
See 675.1 ELECTRICAL CONDUIT.
See 688.7 CONTROLLERS AND 332/336 CABINETS.
See 688.5 STEEL STRAIN POLE AND FOUNDATION.

1.4 Measurement

With the exception of the electrical service cable, electrical cable lengths of the size and numbers of conductors specified, shall be measured by LINEAR FEET as actually furnished and installed, completely in place and accepted, with each size cable being a separate pay item.

1.5 Payment

These items, measured as provided above, will be paid for at the Contract unit price bid for:

*6770388	FURNISH & INSTALL NO. 14 COPPER WIRE, 4 CONDUCTOR - BLACK	LF
6888035	INSTALL NO. 14 COPPER WIRE, 4 CONDUCTOR - BLACK	LF
*6770389	FURNISH & INSTALL NO. 14 COPPER WIRE, 4 CONDUCTOR - GRAY	LF
6888036	INSTALL NO. 14 COPPER WIRE, 4 CONDUCTOR - GRAY	LF
*6770393	FURNISH & INSTALL NO. 14 COPPER WIRE, 8 CONDUCTOR - BLACK	LF
6888037	INSTALL NO. 14 COPPER WIRE, 8 CONDUCTOR - BLACK	LF
*6770394	FURNISH & INSTALL NO. 14 COPPER WIRE, 8 CONDUCTOR - GRAY	LF
6888038	INSTALL NO. 14 COPPER WIRE, 8 CONDUCTOR - GRAY	LF

which shall be full compensation for furnishing all material, labor, equipment, and incidentals necessary for furnishing and installing cable as specified.

Pay Item Notes

* Typically used by SCDOT

This specification is not limited to these pay items. Other pay items may be applicable.

677.2 COMMUNICATION CABLE

1.1 Description

This work shall consist of installing and/or furnishing voice-grade, twisted-pair, telephone-type Communication Cable of the size and type as shown on the Plans or as directed by the ENGINEER, in underground conduit, conduit risers, and/or overhead, complete with all necessary hardware as required.

1.2 Materials

1.2.1 General

The cable and installation shall comply with applicable National specifications, such as the National Electrical Code (NEC); also, the International Municipal Signal Association (IMSA) standards.

Self-Supporting Voice-Grade Communication Cable – OVERHEAD –
SHALL BE IMSA STANDARD 40-4.

Electrical cable supplied under this Specification shall be figure-eight, self-supporting cable that shall include a 1/4 inch diameter, galvanized-stranded-messenger cable with a minimum tensile strength of 28912 6,500 pounds that is integrated into the outer cable jacket. The messenger cable shall support a polyethylene-jacketed, copper-shielded, voice grade cable rated at 300 volts, containing ** twisted-pairs of No. 19 AWG, solid copper conductors which are insulated with polyethylene and are color coded.

Self-Supporting Voice-Grade Communication Cable – UNDERGROUND –
SHALL BE IMSA STANDARD 40-6.

Electrical cable supplied under this Specification shall be polyethylene jacketed, copper-shielded, voice grade cable rated at 300 volts, containing ** twisted-pairs of No. 19 AWG solid copper conductors which are insulated with polyethylene and are color coded.

** The NUMBER OF TWISTED PAIRS shall be as specified on the Plans or the Bid.

1.2.2 Usage

The cables specified above may be used with either low voltage telephone level signals, or may be used with 115 VAC interconnection circuits used with pre-timed controllers.

1.2.3 Supporting Hardware

For overhead installation standard telecommunications industry, non-corroding hardware shall be used to attach the cable to utility or other poles. Cable suspension clamps shall be designed for "Figure Eight" cable, shall have a "J-hook" for installation convenience, and shall include a thru-bolt of the size and length required by the utility company. The suspension clamp shall be appropriate to the "turning angle" of the cable at that point of the installation, including the use of corner suspension clamps where necessary. Dead-ends shall be used as necessary.

1.2.4 Electrical Conduit

Where required, all conduit and fittings supplied shall be installed as described in the appropriate Specification.

See 675.1 ELECTRICAL CONDUIT.

1.2.5 Certification

The CONTRACTOR SHALL PROVIDE certified TEST RESULTS from the Manufacturer, showing that the cable to be furnished has passed all IMSA specified tests. The Manufacturer shall agree to provide the ENGINEER free-access to the factory to observe the manufacturing process.

The CONTRACTOR SHALL FURNISH design details and shop drawings in sufficient detail for complete evaluation of the cable and comparison with these Specifications. Any exceptions to these Specifications must be stated in writing.

CATALOG CUTS ARE REQUIRED

1.2.6 Warranty

The CONTRACTOR shall furnish the ENGINEER with any warranties on equipment and material, which are provided by the Manufacturer or Vendor, as normal trade practice.

1.2.7 Labeling and Delivery

Unless otherwise stated, the cable shall be supplied in minimum reels of 2,500 feet, for splice-free installation.

The Manufacturer shall be required to mark each cable and cable reel to facilitate easy identification of the various sizes when stored in stockpiles.

1.3 Construction

1.3.1 Communication Cable

Communication cable shall be installed where, and in the manner indicated on the Plans, or as directed by the ENGINEER. The attached color code shall be followed.

1.3.2 Underground

When installed underground, all communication cable will be installed in conduit, of the size and type shown on the Plans.

When cable is pulled through Ducts or Manholes, the installation shall be performed ACCORDING TO UTILITY COMPANY SPECIFICATIONS, IN DESIGNATED DUCTS, WITH A UTILITY COMPANY INSPECTOR STANDING BY. Lateral runs shall be made to Controller or Splice Cabinets. No splices shall be made in a Utility Company manhole.

Existing conduits or ducts shall be reamed prior to use.

In manholes, cable shall be wrapped with plastic tracer tape, and shall also be tagged with indelible label similar to "LOW VOLTAGE TRAFFIC SIGNAL CABLE".

At completion, Ducts shall be sealed/plugged per Utility Company requirements.

1.3.3 Overhead

When overhead installation is shown on the Plans, self-supporting cable shall be used according to the following--

Where shown on the Plans, overhead communications cable shall be installed on wood poles. Cables shall be attached to utility poles by means of standard hardware as shown on the Plans and IN ACCORDANCE WITH THE REQUIREMENTS OF THE OWNER (UTILITY COMPANY).

Unless stated by the Utility Company, attachments to utility poles shall be made a minimum of 10 feet below primary electrical cables or other facilities carrying 750 volts or more. A minimum vertical clearance of 18 feet above Interstate and arterial highways shall be maintained.

Vertical cable runs mounted on the outside of poles shall be installed in proper conduit risers. See FURNISH AND INSTALL ELECTRIC CONDUIT.

Where shown on the Plans, communications cable may be installed overhead between an splice cabinet and a controller cabinet, via existing strain poles and signal span wire. The locations involved are shown on the Plans. Cable Supports attached to the span wire, shall be used.

1.3.4 Splices

CABLE RUNS SHALL BE SPLICE-FREE. Splices shall only be allowed ABOVE GROUND, in either CONTROLLER CABINETS, or SPLICE-CABINETS, or SAMPLING STATIONS, or AERIAL TERMINAL BOXES as shown on the plans.

1.3.5 Connections

In controller-, splice-, and sampling station-cabinets, and aerial terminal boxes, the cables shall be connected to firmly mounted terminal blocks. Terminal Blocks shall be telephone quality, R66 "Quick-Connect M-type", having ___ pairs capability, and use a "Stand-Off Mounting".

Connection shall also be made to cables/harnesses required by the Remote Communication Unit (RCU), or sampling station detectors, per Manufacturer's instructions.

Grounding and/or lightning protection shall be installed, in accordance with the requirements of the controller or modem Manufacturer, and shall be incidental to this item. If directed by the Manufacturer, the UN-USED PAIRS of the communication cable shall be connected to ground at one or more point(s).

At each cabinet, communication cable shielding shall be grounded to the earth ground system.

1.3.6 Testing

The CONTRACTOR IS COMPLETELY RESPONSIBLE FOR TESTING THE COMMUNICATION CABLE SYSTEM. Following complete installation and connection of the communication cable, it shall be tested BY THE CONTRACTOR; from INTERSECTION TO INTERSECTION, and THE ENTIRE LENGTH from the FIRST TO LAST INTERSECTION. Surge protection shall be disconnected during some tests, and then reconnected. During some tests, the communication lines shall be disconnected from the 2070 or 170 controller.

Tests performed by the CONTRACTOR shall include:

- a) A high-impedance FET voltmeter shall be connected to each pair, to determine if stray DC/AC voltages are present.

- b) An insulation resistance test shall be performed, using a portable hand-held "Megger". Tests shall be performed between pairs, and to ground. The resistance shall be greater than 10 meg-ohms at 500 V.
- c) An attenuation test shall be performed. The technician shall "Ring-Out" each twisted pair for continuity test, recording the round trip loop resistance, which shall be less than (18.5 ohms per 1000 feet).
- d) A sound powered telephone shall be connected to each pair, one by one. The quality of transmission shall be recorded on a scale of 1 to 5 (five being the best).
- e) If necessary, the CONTRACTOR shall be prepared to fully trouble-shoot the cable system in the event of problems, using a computer type DIGITAL TEST INSTRUMENT, and/or an oscilloscope.

Tests shall be witnessed by the ENGINEER.

1.3.7 Incidentals

Weather (Service) heads shall be used wherever the cable directly enters a strain pole or a vertical conduit riser run.

Drip Loops of at least 8 inches shall be provided at all overhead entrance points such as strain poles and vertical conduits.

Slack shall be provided at pull boxes, splice boxes, interconnect cabinets, controller cabinets and other junction points. 3 feet of cable slack shall be provided, neatly coiled, tied-off, and positioned in the bottom of the enclosure.

All electrical cable pulled in conduit shall be drawn in place, free from electrical or mechanical injury. When a lubricating agent is needed, a wire-pulling compound compatible with the cable insulation shall be used.

1.4 Measurement

Communications cable, of the type and size specified will be measured by LINEAR FEET of cable actually furnished and installed, completely in place and accepted. Each cable size shall constitute a separate pay item, where indicated.

Aerial Terminal Boxes shall be NOT be measured, but are required, and shall be considered incidental to overhead cable installation.

NOTE: Electrical conduit, pull boxes, splice cabinets, and steel span wire are listed elsewhere as separate pay items.

1.5 Payment

Communications cable measured as provided above and accepted will be paid for at the unit price bid per linear feet for:

6770450	FURNISH & INSTALL ELECTRICAL COMMUNICATIONS CABLE - OVERHEAD - 6 PAIR	LF
6888040	INSTALL ELECTRICAL COMMUNICATIONS CABLE - OVERHEAD - 6 PAIR	LF
6770453	FURNISH & INSTALL ELECTRICAL COMMUNICATIONS CABLE - OVERHEAD - 12 PAIR	LF
6888041	INSTALL ELECTRICAL COMMUNICATIONS CABLE - OVERHEAD - 12 PAIR	LF
6770456	FURNISH & INSTALL ELECTRICAL COMMUNICATIONS CABLE - OVERHEAD - 18 PAIR	LF
6888042	INSTALL ELECTRICAL COMMUNICATIONS CABLE - OVERHEAD - 18 PAIR	LF
6770459	FURNISH & INSTALL ELECTRICAL COMMUNICATIONS CABLE - OVERHEAD - 25 PAIR	LF
6888043	INSTALL ELECTRICAL COMMUNICATIONS CABLE - OVERHEAD - 25 PAIR	LF
677045C	FURNISH & INSTALL ELECTRICAL COMMUNICATIONS CABLE - OVERHEAD - 50 PAIR	LF
6888044	INSTALL ELECTRICAL COMMUNICATIONS CABLE - OVERHEAD - 50 PAIR	LF
6770460	FURNISH & INSTALL ELECTRICAL COMMUNICATIONS CABLE - UNDERGROUND - 6 PAIR	LF
6888045	INSTALL ELECTRICAL COMMUNICATIONS CABLE - UNDERGROUND - 6 PAIR	LF
6770463	FURNISH & INSTALL ELECTRICAL COMMUNICATIONS CABLE - UNDERGROUND - 12 PAIR	LF
6888046	INSTALL ELECTRICAL COMMUNICATIONS CABLE - UNDERGROUND - 12 PAIR	LF
6770466	FURNISH & INSTALL ELECTRICAL COMMUNICATIONS CABLE - UNDERGROUND - 18 PAIR	LF
6888047	INSTALL ELECTRICAL COMMUNICATIONS CABLE - UNDERGROUND - 18 PAIR	LF
6770469	FURNISH & INSTALL ELECTRICAL COMMUNICATIONS CABLE - UNDERGROUND - 25 PAIR	LF
6888048	INSTALL ELECTRICAL COMMUNICATIONS CABLE - UNDERGROUND - 25 PAIR	LF
677046C	FURNISH & INSTALL ELECTRICAL COMMUNICATIONS CABLE - UNDERGROUND - 50 PAIR	LF
6888049	INSTALL ELECTRICAL COMMUNICATIONS CABLE - UNDERGROUND - 50 PAIR	LF

Aerial Terminal Boxes shall NOT be paid, but shall be considered incidental to the installation of Overhead Communications cable.

Such payment shall be full compensation for furnishing all material, labor, hardware, equipment and incidentals necessary for furnishing and installing communications cable and completing the work as specified.

Pay Item Notes

This specification is not limited to these pay items. Other pay items may be applicable.

677.3 FIBER OPTIC CABLE

1.1 Description

This work shall consist of installing and/or furnishing single-mode fiber optic (SMFO) cable in conduit and risers or overhead lashed to new messenger cable. The CONTRACTOR shall furnish all attachment hardware and installation guides necessary to install the fiber optic cable.

1.2 Materials

1.2.1 Cable

The cable shall meet all requirements stated in RUS-90 as well as those stated within this specification. The cable shall be an accepted product of the United States Department of Agriculture Rural Utility Service as meeting the requirements of RUS-PE-90. The cable shall be new, unused, and of current design and manufacture.

The single-mode fiber used in the cable shall conform to the following specifications:

Typical Core Diameter:	8.3 μm
Cladding Diameter:	125.0 + 1.0 μm by fiber end measurement
Core-to-Cladding Offset:	< 1.0 μm
Cladding Non-Circularity:	< 2.0% (Defined as: $[1 - (\text{min. cladding dia.} / \text{max. cladding dia.})] \times 100$)
Coating Diameter:	250 + 15 μm
Attenuation Uniformity:	No point discontinuity greater than 0.1 dB at either 1300 nm or 1550 μm .

The change in attenuation at extreme operational temperatures for single-mode fibers shall not be greater than 0.40 dB/km at 1550 nm and 0.5 at 1310 nm, with 80% of the measured values no greater than 0.10 dB/km at 1550 nm.

The maximum dispersion shall + 3.3 ps/(nm • km) for 1285 nm through 1330 and shall be < 18 ps/(nm • km) at 1550 nm.

1.2.2 Fiber Characteristics

All fibers in the cable shall be usable fibers and meet required specifications.

All optical fibers shall be sufficiently free of surface imperfections and inclusions to meet the optical, mechanical, and environmental requirements to this specification. Each optical fiber shall consist of a doped silica core surrounded by a concentric silica cladding.

The coating shall be a dual-layered, UV cured acrylate applied by the fiber manufacturer. The coating shall be capable of being mechanically or chemically striped without damaging the fiber.

1.2.3 Specification of Cables

Optical fibers shall be placed inside a loose buffer tube.

Two (2) buffer tubes, each containing six (6) single-mode fibers shall be furnished. The fibers shall not adhere to the inside of the buffer tube. Each buffer tube shall contain six (6) fibers.

Each fiber shall be distinguishable from each other by means of color coding according to the following.

1. Blue
2. Orange
3. Green
4. Brown
5. Slate
6. White

These colors shall meet EIA/TIA-598, "Color Coding of Fiber Optic Cables". Buffer tubes containing fibers shall also be color coded with distinct and recognizable colors according to the following.

1. Blue
2. Orange
3. Green
4. Brown
5. Slate
6. White
7. Red
8. Black
9. Yellow
10. Violet
11. Rose
12. Aqua

These colors shall meet EIA/TIA-598, "Color Coding of Fiber Optic Cables". Buffer tubes shall be of a dual-layer construction with the inner layer made of polycarbonate and the outer layer made of polyester. Fillers may be included in the cable core to lend symmetry to the cable cross-section where needed.

Each buffer tube shall be filled with a non-hygroscopic, electrically non-conductive, homogenous gel. The gel shall be free from dirt and foreign matter. The gel shall be readily removable with conventional non-toxic solvents.

Buffer tubes shall be stranded around a central member using the reverse oscillation, or "SZ" stranding process.

Binders shall be supplied with sufficient tension to secure the buffer tubes to the central member without crushing the buffer tube. The binders shall be non-hygroscopic, non-wicking (or rendered so by the flooding compound), and dielectric with low shrinkage.

The cable shall contain a central member that is intended to prevent buckling of the cable. The central anti-buckling member shall consist of a glass reinforced plastic rod.

The cable shall contain at least one (1) ripcord under the sheath for easy sheath removal.

Tensile strength shall be provided by high tensile strength aramid yarns and fiberglass. The high tensile strength aramid yarns/fiberglass shall be vertically stranded evenly around the cable core. All cable shall be sheathed with medium density polyethylene. The minimum nominal jacket thickness shall be 1.4 mm. Jacketing material shall be applied directly over the tensile strength members and flooding compound. The jacket or sheath shall be free of holes, pits and blisters.

The jacket shall have "Grabber" brand cable (stock No. VF0G – 07) markers. The markers shall be 6 inches long, orange in color and read as follows in black: "SCDOT TRAFFIC SIGNAL FIBER OPTIC CABLE". The cable markers shall be placed on each side of every pole approximately 2 feet from the pole. The contractor shall install three additional markers on the cable between the poles spaced equally apart along the span.

The maximum pulling tension shall be 2700 N (600 lbs.) during installation (short-term) and 600 N (135 lbs.) long-term installed.

The shipping, storage, installation and operating temperature range of the cable shall be -40° C to 70° C.

1.2.4 Quality Assurance Provisions

All optic fibers shall be proof tested by the fiber manufacturer at a minimum load of 50 kpsi.

All optical fibers shall be 100% attenuation tested by the manufacturer. The attenuation of each fiber shall be provided with each cable reel.

1.2.5 Certification

The contractor shall provide certified test results from the manufacturer showing the cable furnished has been tested. The CONTRACTOR SHALL FURNISH design details in sufficient detail for complete evaluation of the Proposal and comparison with these Specifications. Any exceptions to these Specifications must be stated in writing.

CATALOG CUTS ARE REQUIRED

1.2.6 Labeling and Delivery

The SMFO cable furnished by the CONTRACTOR shall be packaged on non-returnable wooden reels. The reels shall not contain imperfections such as broken flanges or nails that may cause damage to the cable as it is unreeled.

Both the top and bottom ends of the cable shall be available for testing on the reel. The ends of the cable shall be sealed to prevent the ingress of moisture.

Each cable reel shall have a durable weatherproof label that shows the actual length of cable on the reel.

The SMFO cable shall be spliced only at those points shown in the PLANS. The designated splices are the fibers interconnect centers that are proposed for installation in each controller cabinet. The CONTRACTOR shall order cable in reel lengths that are of sufficient length to require no intermediate splicing of the cable.

1.3 Construction

1.3.1 General

The CONTRACTOR shall take every precaution to ensure the fiber optic cable is not damaged during storage and installation. The fiber optic cable shall not be stepped on by workers or run over by

any vehicle or equipment. The fiber optic cable shall not be pulled along the ground or over or around obstructions.

It shall be the responsibility of the CONTRACTOR to coordinate his overhead and underground construction activities on a continuing basis with each of the utility agencies which have facilities in the immediate vicinity.

The fiber optic cable shall be installed in conduit with other cables only where specifically called out in the PLANS.

Where fiber optic cable is to be installed on overhead poles, the CONTRACTOR shall exercise care in temporary placement of installation equipment to provide safety to the public and to prevent damage to existing facilities. Should the CONTRACTOR cause damage to any existing cables and/or equipment, the CONTRACTOR shall immediately notify the ENGINEER and the affected owner and the CONTRACTOR shall repair or have the repair made at no additional cost.

During installation, the CONTRACTOR shall provide cable blocks at least every 50 feet to guide the cable and reduce pulling tension. All pulling equipment and hardware that will contact the cable during installation must maintain the minimum bend radius of the fiber optic cable as listed in Table 1. Corner blocks, appropriately sized to ensure that the minimum bending radius of the cable is maintained, shall be provided whenever fiber optic cable must be pulled around a corner.

Table 1

Fiber Optic Minimum Bend Radius Chart

Nominal Cable Diameter		Minimum Bend Radius (No Tension) Installed		Minimum Bend Radius (Under Tension)	
Millimeters	Inches	Centimeters	Inches	Centimeters	Inches
6.0 – 10.0	(1/4 – 3/8)	10.0	(4.0)	15.0	(6.0)
10.1 – 15.0	(4/10 – 6/10)	15.0	(6.0)	22.5	(9.0)
15.1 – 20.0	(10/16 – 8/10)	20.0	(8.0)	25.0	(10.0)
20.1 – 23.0	(13/16 – 9/10)	23.0	(9.0)	25.0	(10.0)
23.1 – 25.0	(15/16 – 1.0)	25.0	(10.0)	30.0	(12.0)

Fiber optic cable runs shall be continuous between allowable splice points in the fiber interconnect centers cabinet splice points. The CONTRACTOR shall carefully determine the length of fiber optic cable necessary to reach from termination point to termination point. Splicing of fiber optic cable in conduit, pole bases, manholes, pull boxes, or aerial locations shall not be permitted.

Fiber optic cable shall not be pulled through any intermediate junction box, manhole, pull box, pole base or any other opening in the conduit unless specifically required by the ENGINEER in specific facilities. The necessary length of cable to be installed shall be pulled from one junction box, manhole, pull box, pole base, or cabinet to the immediate next downstream manhole, box, pole base, or cabinet. The remaining length of cable to be installed in the next conduit shall be carefully stored in a manner that is not hazardous to pedestrian or vehicular traffic yet ensures that no damage to the cable shall occur. The cable shall be stored in a manner that shall allow that length of cable to be safely pulled into the next conduit. The ENGINEER shall approve the storing methods to be used.

Cable reel lagging shall remain on the cable reels until they arrive at the pulling site. If the lagging has been removed, the CONTRACTOR shall securely fasten the cable ends to avoid damage during transit.

If the cable must be unreeled during installation, the "figure-eight" configuration shall be used to prevent kinking or twisting of the fiber optic cable. The preferred size of the "figure-eight" is 15 feet with each loop about eight (8) feet in diameter. The fiber optic cable shall not be coiled in a continuous direction except for lengths of 100 feet or less.

The CONTRACTOR shall not increase the tension on the messenger cable to which the fiber optic cable has already been lashed.

At the completion of a day's installation, the CONTRACTOR shall protect the cable from the ingest of moisture by placing a cable cap and/or several wraps of tape on the tip of the cable.

The CONTRACTOR shall record the cable meter marks at every other pole location and at the fiber splice points on a set of as-built plans. Two (2) copies of the plans showing the meter marks shall be provided to the ENGINEER. The meter marks are most easily obtained while forming drip loops.

The CONTRACTOR shall route the fiber optic cable on the inside of messenger intersections at dead ends and crossovers.

1.3.2 Aerial Installation

1.3.2.1 General

Where the plans call for aerial installation, the CONTRACTOR shall furnish new messenger cable (see Furnish and Install Steel Cable) and shall lash the fiber optic cable to the new messenger.

Aerial cable shall be installed either manually or by using the moving reel method. If the CONTRACTOR proposes to use the moving reel method, the CONTRACTOR shall submit to the ENGINEER the cable manufacturer's recommended procedures for this installation technique at least seven (7) days prior to beginning the installation of the fiber optic cable.

The required clearances between the fiber optic cable and the utility features shall be maintained as follows unless otherwise noted on the PLANS:

A minimum of 4 inches vertical clearance and 12 inches minimum total (diagonal) separation shall be maintained to the telephone and/or cable vision facilities.

A minimum of 40 inches vertical clearance shall be maintained to all electrical transformers.

A minimum of 40 inches vertical clearance shall be maintained to all electric lines (including street light circuits).

Relocation of overhead utilities will be made by others and is not a part of this Contract.

Where called for on the PLANS or as directed by the ENGINEER, fiberglass extension arms shall be furnished and utilized to install the new fiber optic cable. Such fiberglass extension arms shall be an MIF PH6-2 or approved equal.

Where called for on the PLANS, the CONTRACTOR shall install down guys, sidewalk guys, and aerial guys as shown in the typical diagrams in the PLANS. Guy guards shall be constructed of #18 hot-dipped galvanized steel. All guy hardware shall be on the same bolt with the J-hook.

The CONTRACTOR shall use a Kellems® (or approved equal) grip wire mesh pulling grip and swivel to prevent damage to the cable during cable pulls.

The CONTRACTOR shall provide drip loops for the fiber optic cable at all utility poles to which the fiber optic cable is attached. The drip loops must be of the "smooth-curve" type and shall be at least of the recommended dimensions for a drip loop in the typical details. Drip loops shall be formed by hand or by using an expansion loop-forming tool. Straps and spacers shall be used to support the cable in the absence of lashing wire support and to hold the cable bundles together. The strap and spacer shall be installed no closer than 4 inches to the first bend in the drip loop.

Where called for on the PLANS, the CONTRACTOR shall install backlashes in the Fiber Optic cable as necessary. The CONTRACTOR shall utilize 16 inch Fiber Optic Strand Storage Bracket (Multilink model number 2116-SSPTB or approved equivalent) which are also known as "Fiber Optic Sno Shoes". All hardware necessary for the installation of the backlash including the "Fiber Optic Sno Shoes", and lashing of the additional cable shall be incidental to the cost of Furnishing and Installing the Fiber Optic cable.

The straps and spacers used for drip loops and other fiber optic cable handling purposes shall be hand-tight only. The strap and spacer must be loose enough to allow longitudinal travel by the cable, but tight enough to prevent the strap and spacer from moving on the messenger cable.

1.3.2.2 Lashing

The fiber optic cable shall be over lashed to the new messenger installed by the CONTRACTOR. The lashing shall be accomplished with aluminum wrapping tape spaced at intervals not exceeding 380 mm or with 1.5 mm (minimum) diameter galvanized steel spiral cable wrap. Wrapping tape, if used shall be 1.3 mm x 7.6 mm. At least 4 turns shall be used. Lashing shall be accomplished in the manner that results in the wire and the cable appearing to be an integral part of the support cable. Fiber optic cable shall be installed without loose lashing, twisting or weaving along the messenger.

The CONTRACTOR shall terminate the lashing wire with a lashing wire clamp as the cable run is lashed up, span-by-span. The lashing wires shall be terminated as follows:

- 1) Place a cable spacer between the fiber optic cable and the messenger.
- 2) Locate lashing wire clamp 2 inches from strap and spacer. Pull enough lashing wire out of lasher to terminate into the lashing wire clamp.
- 3) Wrap the lashing wire 3 times around only the messenger between the lashing wire clamp and the planned location of the first wrap around both the strand and fiber optic cable.
- 4) Secure the lashing wire as shown in the typical details.

1.3.3 ***Underground Installation***

Where shown on the PLANS, the fiber optic cable shall be installed in new underground conduit and risers.

Seven (7) days prior to the installation of fiber optic cable in conduit is performed, the CONTRACTOR shall provide the ENGINEER with 4 copies of the cable manufacturer's recommended and maximum pulling tensions. Included with these pulling tensions shall be a list of the cable manufacturer's approved pulling lubricants. Only those lubricants in the quantity recommended by the fiber optic cable manufacturer shall be approved for use.

When installing the cable in underground conduit, the maximum allowable pulling tension for the cable installation by the CONTRACTOR shall not exceed 70 percent of the manufacturer's maximum pulling tension. If the cable is pulled by mechanical means, a dynamometer (clutch device) approved by the

ENGINEER shall be used to ensure that a maximum allowable pulling tension is not exceeded at any time during installation.

Fiber optic cable shall not be pulled over edges or corners, over or around obstructions or through unnecessary curves or bends. Approved cable guides, feeders, shoes and bushings shall be used to prevent damage to the cable during installation.

Sealing bushings rather than weatherheads shall be used on all risers containing fiber optic cable. The sealing bushings shall conform to the typical detail shown.

Conduit bends and cabinet entrance fittings used by the fiber optic cable network shall be designed to accommodate the bending radius limitations of the fiber optic cable used.

The CONTRACTOR shall pull an adequate amount of fiber optic cable into the controller cabinet to perform splicing and to provide approximately 50 feet of slack cable (approximately 25 feet from the entering and 25 feet from the exiting cable). After the fiber optic cable has been spliced, the cable shall be neatly coiled (with tie-wraps placed on the cable) and placed on top of the fiber interconnect center or on the bottom of the cabinet. The cable shall be readily accessible to enable maintenance personnel to perform splicing of the cable in a vehicle located near the controller cabinet.

1.3.4 Grounding and Bonding

All metal conduits shall be grounded.

All conduit, terminal cabinets, anchor bolts and reinforcing bar cages shall be made mechanically and electrically secure to form a continuous system and shall be effectively grounded. The grounding or bonding conductor shall be #6 AWG bare stranded copper wires.

Bonding of metallic conduit in pull boxes and other installations, where the conduit is not coupled, shall be coupled with metallic conduit ground bushings having smoothly rounded molded insulated inserts and bonding jumpers.

The CONTRACTOR shall furnish and install all grounding facilities.

1.3.5 Fiber Optic Cable Tests

1.3.5.1 Continuity

Prior to the installation of any fiber optic cable, the CONTRACTOR shall test the continuity of each fiber using an Optical Time Domain Reflectometer (OTDR). The test shall be conducted while the fiber is still on the reel and the test results shall be provided to the ENGINEER.

1.3.5.2 Splice Loss

After the installation of the fiber optic cable, the CONTRACTOR shall test the dB loss for every splice of the fiber optic cable in accordance with procedures established in the OTDR operator's manual. The testing may be done in conjunction with the splicing of the cable. Any splice that has a splice loss >0.09 dB shall be re-spliced.

The CONTRACTOR shall provide hardcopy test results to the ENGINEER that identify the location of the splice (Intersection name, splice tray #), the fiber (by buffer tube and fiber color), and the splice loss in dB.

1.3.5.3 Connector/End Splice Testing

The CONTRACTOR shall test each connector/end splice loss in one (1) direction using an OTDR in accordance with procedures established in the OTDR operator's manual. The average mated connector/end splice loss shall be <0.5 dB. Individual mated connector pair/end loss shall be <0.7 dB. Any connector/end splice with a loss greater than 0.7 dB shall be replaced, by the CONTRACTOR. Any replacement connectors/ends shall also be tested.

1.3.5.4 End-to-End Attenuation Testing

The CONTRACTOR shall perform end-to-end testing of each fiber between each place point at 1310 nm and 1550 nm in one (1) direction in accordance with EIA/TIA 526-7.

The CONTRACTOR shall provide hardcopy test results to the ENGINEER that identify the two (2) ends of the test site, the fiber tested, the wavelength tested, the reference power output, and the system attenuation in dB.

The CONTRACTOR shall provide OTDR Signature traces of all fibers between all intersections for system documentation and restoration purposes.

1.4 Measurement

Fiber optic cable, of the type and size specified will be measured by linear feet of cable actually furnished and installed, completely in place and accepted, using an "OTDR" (optical time-domain reflectometer).

Note that electrical conduit, splice boxes, splice cabinets, and steel span wire are listed elsewhere as separate pay items.

1.5 Payment

Fiber optic cable measured as provided above and accepted will be paid for at the unit price bid per linear feet for:

6770470	FURNISH & INSTALL FIBER OPTIC CABLE – SINGLE MODE	LF
677046D	FURNISH & INSTALL SELF SUPPORTING FIBER OPTIC CABLE - SINGLE MODE	LF
6888080	INSTALL OPTICAL FIBER CABLE	LF

Such payment shall be full compensation for furnishing all material, labor, hardware, equipment and incidentals necessary for furnishing and installing communications cable and completing the work as specified.

Pay Item Notes

This specification is not limited to these pay items. Other pay items may be applicable.

677.4 FIBER INTERCONNECT CENTER

1.1 Description

This work shall consist of installing and/or furnishing a Fiber Interconnect Center. Included in this item is the splicing of the fiber optic cable; furnishing and installing splice trays, interconnection sleeves, jumpers, connectors and other hardware that may be needed for connecting the fiber optic cable to the signal system electronic devices.

1.2 Materials

Acceptable materials can be found on the current SCDOT Qualified Products List. Product Specifications for acceptable materials are located at http://www.scdot.org/doing/publications_Traffic.aspx

1.3 Construction

1.3.1 Cabinet

The Fiber Interconnect Center shall be installed by the CONTRACTOR in the new, or reused controller cabinet. The Fiber Interconnect Center shall be located in the cabinet such that the slack fiber optic cable stored on top of the fiber interconnect center (as required in the special provision – Furnish and Install Fiber Optic Cable) can be easily removed (along with the fiber interconnect center) from the cabinet and taken to a maintenance vehicle for splicing, if necessary.

1.3.2 Splicing Methods

All splicing shall be done by means of a fusion splice technique, which induces less than 0.3 dB attenuation. Bare fibers shall be completely recoated with a protective RTV gel or similar substance prior to application of the sleeve or housing to protect the fiber from scoring, dirt, or microbending. Each spliced fiber shall be packaged in a heat shrink protective sleeve or housing. All splices shall be performed in accordance with the cable manufacturer's and the splice manufacturer's recommendations. During splicing, the CONTRACTOR shall maintain the continuity of the buffer tube and fiber color.

Incoming fibers shall be provided with 5 feet of coiled slack and spliced to a pigtail of the same type fiber. Pigtails shall have a minimum length of 5 feet and shall have a factory-installed ST compatible connector. The pigtails shall have an attenuation of less than 0.3 dB. The ST connector shall mate with the connector panels installed in the fiber interconnect center.

Unused optical fibers shall be properly protected with sealed end caps.

The CONTRACTOR shall record the meter marks on the cable sheath at each splice point. These marks shall be provided to the owner on a sheet of as-built system plans at the completion of the project.

1.3.3 Jumpers

The CONTRACTOR shall furnish and install 2 single-mode fiber optic cable assemblies with connectors factory-installed on each end (jumpers). These assemblies will be used to connect the fiber optic modem to the connector panel. These jumpers will not be paid for directly but shall be considered incidental to the item Furnish and Install Fiber Optic Modem.

1.3.4 Future Applications

The fiber optic communications network is being designed and constructed to accommodate future applications. As shown in the typical details, all 6 fibers in 1 buffer tube of the entering cable shall be fusion spliced through to the 6 fibers in 1 of the buffer tubes leaving the cabinet. The continuity of the buffer tube and fiber color shall be maintained. These fibers shall be spliced in a separate splice tray. The cable entering and exiting the cabinet will contain another buffer tube that contains 6 fibers. 3 of the incoming and 3 of the outgoing fibers shall be fusion spliced to pigtail assemblies with factory-installed type ST compatible connectors. These 6 splices shall be placed in a second splice tray. The remaining 3 incoming and 3 outgoing fibers shall be fusion spliced to pigtail assemblies with factory-installed type ST compatible connectors and placed in a third tray. All pigtail assemblies shall be connected by the CONTRACTOR to the connector panels installed in the Fiber Interconnect Center. The Transmit and Receive designations of each fiber pair shall be clearly labeled on the front of the connector panel. Each fiber termination/connection shall be tested for attenuation.

1.3.5 Fiber Optic Cable Tests

1.3.5.1 Continuity

Prior to the installation of any fiber optic cable, the CONTRACTOR shall test the continuity of each fiber using an Optical Time Domain Reflectometer (OTDR). The test shall be conducted while the fiber is still on the reel and the test results shall be provided to the ENGINEER.

1.3.5.2 Splice Loss

After the installation of the fiber optic cable, the CONTRACTOR shall test the dB loss for every splice of the fiber optic cable in accordance with procedures established in the OTDR operator's manual. The testing may be done in conjunction with the splicing of the cable. Any splice that has a splice loss >0.09 dB shall be re-spliced.

The CONTRACTOR shall provide hardcopy test results to the ENGINEER that identify the location of the splice (Intersection name, splice tray #), the fiber (by buffer tube and fiber color), and the splice loss in dB.

1.3.5.3 Connector/End Splice Testing

The CONTRACTOR shall test each connector/end splice loss in one (1) direction using an OTDR in accordance with procedures established in the OTDR operator's manual. The average mated connector/end splice loss shall be <0.5 dB. Individual mated connector pair/end loss shall be <0.7 dB. Any connector/end splice with a loss greater than 0.7 dB shall be replaced, by the CONTRACTOR. Any replacement connectors/ends shall also be tested.

1.3.5.4 End-to-End Attenuation Testing

The CONTRACTOR shall perform end-to-end testing of each fiber between each place point at 1310 nm and 1550 nm in one (1) direction in accordance with EIA/TIA 526-7.

The CONTRACTOR shall provide hardcopy test results to the ENGINEER that identify the two (2) ends of the test site, the fiber tested, the wavelength tested, the reference power output, and the system attenuation in dB.

The CONTRACTOR shall provide OTDR Signature traces of all fibers between all intersections for system documentation and restoration purposes.

1.4 Measurement

This item shall include the labor, equipment, and materials necessary to furnish and install the fiber optic interconnect centers in accordance with the PLANS and Project Special Provisions. This item shall be measured by the number of each installed.

1.5 Payment

The fiber interconnect center, as measured above, will be paid for at the contract unit price bid for:

6770476	FURNISH & INSTALL FIBER OPTIC INTERCONNECT CENTER	EA
6888092	INSTALL FIBER OPTIC INTERCONNECT CENTER	EA

which shall be full compensation for furnishing and installing the fiber interconnect centers into the signal controller cabinets and making the necessary connections. The fusion splicing of the cable, furnishing and installing the splice trays, pigtail assemblies, connector panels and interconnection sleeves shall be considered incidental to this item and will not be paid directly.

Pay Item Notes

This specification is not limited to these pay items. Other pay items may be applicable.

677.5 FIBER OPTIC MODEM

1.1 Description

This work shall consist of installing and/or furnishing a Fiber Optic Modem as shown on the plans or as established by the ENGINEER, in accordance with these specifications.

1.2 Materials

Acceptable materials can be found on the current SCDOT Qualified Products List. Product Specifications for acceptable materials are located at http://www.scdot.org/doing/publications_Traffic.aspx

1.3 Construction

1.3.1 Mechanical Interface

The OTR/RP shall be acceptable as a stand-alone unit mounted externally to the traffic controller or as an electronic device to be internally installed within the traffic controller. In either configuration, the OTR/RP design shall be modular with replaceable components which are easily accessible to maintenance personnel. The OTR/RP shall include visual signal indicators associated with communications between the OTR/RP units as listed below:

1. Transmit Data Optical Channel 1 (TD-1)
2. Receive Data Optical Channel 1 (RD-1)
3. Transmit Data Optical Channel 2 (TD-2)
4. Receive Data Optical Channel 2 (RD-2)
5. Request to Send (RTS)
6. Clear to Send (CTS)
7. Power On (PWR)
8. OTR/RP Fail - Anti-streaming Activated

An anti-streaming reset switch shall be provided to reset the OTR/RP, should the anti-streaming function be activated.

1.3.2 Physical Interface

All OTR/RPs shall, at the CONTRACTOR'S option, be either external or internal to the controller.

1.3.2.1 If External to the Traffic Controller

OTR/RP(s) installed externally to the traffic controller shall be interchangeable between traffic controller cabinets. To this extent, the OTR/RP shall conform to standard mounting and interconnection provisions within the controller cabinet. The OTR/RP shall conform to the specified dimensions of 4.5 inch wide (114.3 mm) x 5.12 inch deep (130.1 mm) x 1.0 inch high (25.4 mm). A 10% variation is allowable; however, all OTR/RP(s) provided shall conform to the same dimensions to assure interchangeability. The mounting plate attached to the OTR/RP shall have mounting holes manufactured to the tolerances stated herein to assure interchangeability of units within controller cabinets.

Connectors shall be located on the OTR/RP for convenient cable attachments. Strain reliefs shall be included on all cables provided with the OTR/RP. Signal indicators shall be easily viewable when the OTR/RP is mounted in a controller cabinet.

Construction and materials selected for the OTR/RP shall prevent fungus growth and cathodic action. Flame retardant materials shall be utilized in the construction of OTR/RP electronics.

The OTR/RP shall be provided in an aluminum housing which has been treated to prevent corrosion. All connectors and replaceable components shall be marked or labeled with identification conforming to the supplied equipment documentation, including schematics and parts lists. The OTR/RP external markings shall include the product name, model number, part number, serial number, manufacturer's name, and manufacturer's address.

The OTR/RP shall be free of sharp corners. Power input requirements, both voltage and current, shall be marked on the OTR/RP case. All power interconnections shall be protected against inadvertent contact by maintenance personnel. Any safety handling related instructions will be plainly marked on the OTR/RP case. The OTR/RP shall be shipped from the factory with protective connector covers.

1.3.2.2 If Internal to the Traffic Controller

An OTR/RP(s) circuit assembly to be internally installed within the traffic controller shall be interchangeable between traffic controllers. To this extent, the OTR/RP circuit assembly shall conform to the standard mounting and interconnection provisions within the controller chassis.

Connectors shall be located on the OTR/RP circuit assembly for convenient cable attachments. Strain reliefs shall be included on all cables provided with the OTR/RP. OTR/RP signal indicators shall be easily viewable when the traffic controller is mounted in a controller cabinet.

Construction and materials selected for the OTR/RP circuit assembly shall prevent fungus growth and cathodic action. Flame retardant materials shall be utilized in the construction of the OTR/RP circuit assembly.

The OTR/RP circuit assembly shall be marked or labeled to the extent possible with identification conforming to the supplied equipment documentation, including schematics and parts lists. The OTR/RP circuit assembly external markings shall include the product name, model number, part number, serial number, manufacturer's name, and manufacturer's address.

The OTR/RP circuit assembly shall be shipped from the factory with protective connector covers.

1.3.3 **Environmental**

The OTR/RP shall conform to the performance specifications stated herein when operated in the following environment:

Temperature: -34°C to 70°C

Humidity: 0 to 98% RH with minimal condensation

No cooling air flow shall be required. The unit shall be sealed to the extent that it may be damaged by blowing sand and dust. Units shall be shipped with protective covers over all connectors.

1.4 **Measurement**

The OTR/RP shall be measured by the number of EACH installed in place as required on the PLANS, including a power supply and RS-232 cable.

1.5 Payment

Each type of OTR/RP, accepted and measured as stated herein, shall be paid for at the contract unit price bid for:

6770482	FURNISH & INSTALL FIBER OPTIC MODEM	EA
6888091	INSTALL FIBER OPTIC MODEM	EA

which shall be full compensation for furnishing all materials, equipment, labor, and incidentals necessary to complete the work specified herein. The power supply and RS-232 cable shall be considered incidental to this item and will not be paid directly.

Pay Item Notes

This specification is not limited to these pay items. Other pay items may be applicable.

677.6 FACTORY TERMINATED PATCH PANEL

1.1 Description

This work shall consist of installing and/or furnishing a Factory Terminated Patch Panel. Included in this item is the splicing of the fiber optic cable; installing interconnection sleeves, jumpers, connectors and other hardware that may be needed for connecting the fiber optic cable to the signal system electronic devices.

1.2 Materials

Acceptable materials can be found on the current SCDOT Qualified Products List. Product Specifications for acceptable materials are located at http://www.scdot.org/doing/publications_Traffic.aspx

1.3 Construction

The factory terminated patch panel shall be installed by the CONTRACTOR in the new, or reused controller cabinet. The factory terminated patch panel shall be located in the cabinet such that the slack fiber optic cable is safely stored (as required in the special provision – Furnish and Install Fiber Optic Cable) and can be easily removed (along with the factory terminated patch panel) from the cabinet and taken to a maintenance vehicle for splicing, if necessary.

1.3.1 Splicing Methods

All splicing shall be done by means of a fusion splice technique, which induces less than 0.3 dB attenuation. Bare fibers shall be completely recoated with a protective RTV gel or similar substance prior to application of the sleeve or housing to protect the fiber from scoring, dirt, or microbending. Each spliced fiber shall be packaged in a heat shrink protective sleeve or housing. All splices shall be performed in accordance with the cable manufacturer's and the splice manufacturer's recommendations. During splicing, the CONTRACTOR shall maintain the continuity of the buffer tube and fiber color.

Unused optical fibers shall be properly protected with sealed end caps.

The CONTRACTOR shall record the meter marks on the cable sheath at each splice point. These marks shall be provided to the owner on a sheet of as-built system plans at the completion of the project.

1.3.2 Jumpers

The CONTRACTOR shall furnish and install 2 single-mode fiber optic cable assemblies with connectors factory-installed on each end (jumpers). These assemblies will be used to connect the fiber optic modem to the Factory terminated patch panel. These jumpers will not be paid for directly but shall be considered incidental to the item Furnish and Install Factory terminated patch panel.

1.3.3 Fiber Optic Cable Tests

1.3.3.1 Continuity

Prior to the installation of any fiber optic cable, the CONTRACTOR shall test the continuity of each fiber using an Optical Time Domain Reflectometer (OTDR). The test shall be conducted while the fiber is still on the reel and the test results shall be provided to the ENGINEER.

1.3.3.2 Splice Loss

After the installation of the fiber optic cable, the CONTRACTOR shall test the dB loss for every splice of the fiber optic cable in accordance with procedures established in the OTDR operator's manual. The testing may be done in conjunction with the splicing of the cable. Any splice that has a splice loss >0.09 dB shall be re-spliced.

The CONTRACTOR shall provide hardcopy test results to the ENGINEER that identify the location of the splice (Intersection name, splice tray #), the fiber (by buffer tube and fiber color), and the splice loss in dB.

1.3.3.3 Connector/End Splice Testing

The CONTRACTOR shall test each connector/end splice loss in one (1) direction using an OTDR in accordance with procedures established in the OTDR operator's manual. The average mated connector/end splice loss shall be <0.5 dB. Individual mated connector pair/end loss shall be <0.7 dB. Any connector/end splice with a loss greater than 0.7 dB shall be replaced, by the CONTRACTOR. Any replacement connectors/ends shall also be tested.

1.3.3.4 End-to-End Attenuation Testing

The CONTRACTOR shall perform end-to-end testing of each fiber between each place point at 1310 nm and 1550 nm in one (1) direction in accordance with EIA/TIA 526-7.

The CONTRACTOR shall provide hardcopy test results to the ENGINEER that identify the two (2) ends of the test site, the fiber tested, the wavelength tested, the reference power output, and the system attenuation in dB.

The CONTRACTOR shall provide OTDR Signature traces of all fibers between all intersections for system documentation and restoration purposes.

1.4 Measurement

This item shall include the labor, equipment, and materials necessary to install the Factory terminated patch panel in accordance with the PLANS and Project Special Provisions. This item shall be measured by the number of each installed.

1.5 Payment

The Factory Terminated Patch Panel, as measured above, will be paid for at the contract unit price bid for:

6888082	FURNISH & INSTALL FACTORY TERMINATED PATCH PANEL	EA
6888093	INSTALL FACTORY TERMINATED PATCH PANEL	EA

The bid for the Factory terminated patch panel shall include the cost of furnishing and installing the Factory terminated patch panel into the signal controller cabinets and making the necessary connections. The fusion splicing of the cable, pigtail assemblies, connector panels and interconnection sleeves shall be considered incidental to this item and will not be paid directly.

Pay Item Notes

This specification is not limited to these pay items. Other pay items may be applicable.

677.7 SPREAD SPECTRUM RADIO ASSEMBLY

1.1 Description

This work shall consist of installing and/or furnishing a Spread Spectrum wireless radio system with all necessary hardware in accordance with the plans and specifications to provide a data link between field devices (i.e. Traffic Signal Controllers). Provide a radio system with a bi-directional, full duplex communications channel between two "line-of-sight" antennas using license free, spread spectrum technology operating in the 902-928 MHz frequency band. Product shall be compatible with the current SCDOT software and 2070L controller.

1.2 Materials

1.2.1 900MHz Wireless Radio Systems

Furnish license free 902 – 928 MHz radio modems with antennas, coaxial cable and mounting hardware, and configuration software. Design radio modems to work in "point-to-point", "point-to-multipoint", "multipoint-to-point", and "multipoint-to-multipoint" configurations. Ensure the spread spectrum wireless radio meets the following minimum requirements:

- License free (ISM) Spread Spectrum radio band (902 – 928 MHz)
- Frequency Hopping Technology (Direct Sequence Spread Spectrum Technology is not acceptable)
- Bi-Directional, Full Duplex
- Programmable Radio Frequency (RF) output levels of 1mW, 10mW, 100mW, or 1 Watt
- A minimum of 128 user-selectable radio frequency channels, with selectable hopping sequences (2 non-overlapping)
- RS-232 interface capable of operating from 1200 bps to 115.2 Kbps
- DB9-F or DB25-F connector for RS-232 port
- Maximum of 8 ms. end-to-end latency
- Cyclic Redundancy Check (CRC) error-checking
- Receiver Sensitivity of -110dBm @ 10^{-6} BER
- Antenna port: Threaded Normalized Connector (TNC) antenna connector
- Front panel LED indicators:
 - Power
 - Transmit Data
 - Receive Data
- Operating temperature of -40 to $+176$ degrees F at 0 to 95% Humidity
- Power supply requirements:
 - Wall Adapter: 120 VAC UL/CSA wall cube plug-in module with 12 VDC, 1 Amp, nominal output.
 - Typical current draw of no greater than 500 mA when powered with 12 VDC input, and transmitting 1 Watt of RF output power.
- Shelf mounted design not to exceed 9" long x 3" wide x 6" high (2070H1 Slot Compatible)

Furnish a Radio Frequency Signal Jumper constructed of an RG-58 Coaxial Cable for connection to the lightning arrestor. Provide the jumper in 6 foot lengths.

Furnish an RS-232 data interface cable to be installed between the radio modem and the field device's RS-232 interface. Ensure cable is a minimum of 6 feet long.

Ensure that installing the wireless radio system with a fully functional field device (i.e. traffic controller) does not require any field device modifications with regards to hardware or software.

1.2.2 900MHz Wireless Repeater Radio System

Furnish an operational 900MHz wireless repeater radio system if necessary, to ensure the radio system functions as designed. As a minimum, ensure the 900Mhz Wireless repeater radio meets the specifications provided above.

1.2.3 Software

Furnish units with a Windows™ based software program that uses a GUI (Graphical User Interface) to provide “remote programming, radio configuration, remote maintenance, diagnostics and spectrum analyzer” features. Provide software that is designed to function with the approved wireless radio. Provide configuration software that can be upgraded in the future at no additional charge.

Ensure the radio modem is configurable from a single location (i.e. master radio location) via supplied software. Furnish software to allow easy set-up with all industry standard traffic signal controllers, including 2070 controllers containing software written specifically for the South Carolina Department of Transportation.

1.2.4 Directional Antenna (Yagi)

Furnish a directional antenna that will allow the system to function as designed. Furnish 8.5 dB Gain or 13 dB Gain antennas that meet the following minimum specifications:

8.5 dB Gain:

Frequency Range	896 – 940 MHz
Nominal Gain	8.5 dB
Front to Back Ratio	18 dB
Horizontal Beamwidth (at half power points)	65 degree
Vertical Beamwidth (at half power points)	55 degree
Power Rating, UHF Frequency	200 Watts
Lightning Protection	DC Ground
Termination	Coaxial pigtail with a Standard N-Type Female Connector
Impedance	50 ohms
Length	24"
Rated Wind Velocity	125 mph
Rated Wind Velocity (with 0.5 inch radial ice)	100 mph
Projected Wind Surface Area (flat plane equivalent)	0.26 ftsq.
Number Elements	6
Allows for Vertical or Horizontal polarization	
Minimum separation distance from persons installing and using an active device	9"
Minimum separation distance from other RF sources including radios and antennas	6.5'
Welded construction	

13 dB Gain:

Frequency Range	902 – 928 MHz
Nominal Gain	13 dB
Front to Back Ratio	20 dB
Horizontal Beamwidth (at half power points)	40 degree
Vertical Beamwidth (at half power points)	35 degree
Power Rating, UHF Frequency	200 Watts
Lightning Protection	DC Ground
Termination	Coaxial pigtail with a Standard N-Type Female Connector
Impedance	50 ohms
Length	53"
Rated Wind Velocity	125 mph
Rated Wind Velocity (with 0.5 inch radial ice)	100 mph
Projected Wind Surface Area (flat plane equivalent)	0.46 ftsq.
Number Elements	13
Allows for Vertical or Horizontal polarization	
Minimum separation distance from persons installing and using an active device	9"
Minimum separation distance from other RF sources including radios and antennas	6.5'
Welded construction	

Furnish mounting hardware to secure the antenna to the metal pole or wood pole, as recommended by the manufacturer of the antenna and as approved by the Engineer.

1.2.5 Omni-Directional Antenna

Furnish an omni-directional antenna that will allow the system to function as designed. Furnish 3dB or 6dB antennas that meet the following minimum specifications:

Frequency Range	902 – 928 MHz
Nominal Gain	Typical gains of 3 or 6 dB (dependent upon gain needed for application)
Termination	Standard N-Type Female Connector
Impedance	50 ohms
VSWR	1.5:1
Vertical Beam Width	3 dB – 33 degrees; 6 dB – 17 degrees
Lightening Protection	DC Ground
Power Rating, UHF Frequency	100 Watts
Length	3dB – 25" 6dB – 65"
Rated Wind Velocity	125 mph
Solid, single piece construction	
Minimum separation distance from persons installing and using an active device	9"
Minimum separation distance from other RF sources including radios and antennas	6.5'
Mount in a vertical direction and limit to vertically polarized RF systems	

Furnish mounting hardware to secure the antenna to the metal pole or wood pole, as recommended by the manufacturer of the antenna and as approved by the Engineer.

1.2.6 Cable From Polyphaser To Antenna Per Foot With Connectors

Furnish an antenna coaxial cable to provide a link between the antenna and the lightning arrester that meets the following minimum specifications:

Attenuation (dB per 100 feet) @ 900 MHz	3.9 dB
Power Rating @ 900 Mhz	0.58 kW
Center Conductor	0.108" Copper Clad Aluminum
Dielectric: Cellular PE	0.285"
Shield	Aluminum Tape – 0.291" Tinned Copper Braid – 0.320"
Jacket	Black UV protected polyethylene
Bend Radius	1" with less than 1 ohm impedance change at bend
Impedance	50 ohms
Capacitance per foot	23.9 pf/ft
End Connectors	Standard N-Type Male Connectors on both ends

1.2.7 Cable From Radio To Polyphaser

Furnish cable to provide a link between the radio and the polyphaser. Cable should be RG-58 Coaxial Cable, complete with connectors in 6 foot lengths.

1.2.8 Cable From Radio To 2070L Controller

Furnish cable to provide a link between the radio and 2070L controller. Cable should be RS-232 data interface cable, complete with connectors, in 6 foot lengths.

1.2.9 Power Supply

The power supply must have a wall adapter with a 120 VAC UL/CSA wall cube plug-in module with 12 VDC, 1 Amp, nominal output. Typical current draw shall not be greater than 500 mA when powered with 12 VDC, and transmitting 1 Watt of RF output power.

1.2.10 Ground Kit

A ground kit shall link the polyphaser to the neutral bar.

1.2.11 Y-Cable For Radio To Fiber

Spec for Y-Cable

1.2.12 Connector For Coaxial Cable [RJ11, DB9, AND RF-(TNC)]

Furnish Standard N-Type Connector(s) of proper sizing to mate with the coaxial cable and utilize a crimping method to secure the connector to the coaxial cable. Furnish a connector that meets the following minimum specifications:

- Center Contact: Gold Plated Beryllium Copper-(spring loaded – Non-solder)
- Outer Contact: Silver Plated Brass
- Body: Silver Plated Brass
- Crimp Sleeve: Silver Plated Copper
- Dielectric: Teflon PTFE
- Water Proofing Sleeve: Adhesive Lined Polyolefin – Heat Shrink
- Attachment Size: Crimp Size 0.429" (minimum) hex

Electrical Properties:

- Impedance: 50 ohms
- Working Voltage: 1000 vrms (max)
- VSWR: 1.25:1 (max) up to 3GHz

Provide instructions on properly installing the connector.

1.2.13 Polyphaser

Furnish a lightning arrestor installed in line between each antenna and its designated radio modem inside the equipment cabinet. Furnish a lightning arrestor that meets the following minimum specifications:

- Surge: 20kA, 800MHz to 2.0GHz $\leq 1.1 : 1$ VSWR
18kA, 800MHz to 2.3GHz $\leq 1.1 : 1$ VSWR
700MHz to 2.7GHz $\leq 1.2 : 1$ VSWR
- Insertion Loss: ≤ 0.1 dB over frequency range
- Max Power: 500 w @ 920MHz (750 W @ at 122° F)
- RF Power: 300 Watts
- Let Through Voltage: $\leq \pm 3$ Volts for 3kA @ 8/20 μ s Waveform
- Throughput energy: ≤ 0.5 μ J for 3kA @ 8/20 μ s Waveform
- Temperature: -40 to 185° F Storage/Operating 122° F
- Vibration: 1G at 5 Hz up to 100Hz
- Unit Impedance: 50 Ω
- VSWR: 1.1:1
- Frequency Range: 800 MHz to 2200 MHz
- Multistrike capability
- Low strike throughput energy
- Flange mount and bulkhead mount options
- Standard N-Type Female Connector on both the surge side and protected side connectors

1.2.14 Certification

CATALOG CUTS ARE REQUIRED

1.2.15 Warranty

The Contractor shall furnish the ENGINEER with any warranties on materials that are provided by the Manufacturer or Vendor as normal trade practice.

1.3 Construction

1.3.1 Radio Path Site Survey

Perform a radio path Site Survey test before installing any equipment. Ensure the test evaluates the Signal Strength (dBm), Fade Margin (dB), Signal-to-Noise Ratio, Data Integrity (poll test), and a complete frequency spectrum scan. Ensure the radio path site survey test is performed using the supplied brand of radio equipment to be deployed. During the initial radio path signal strength test it may be determined that a repeater station may be necessary to complete the intended link. Provide the test results to the ENGINEER for review and approval. Submit copies of the test results and colored copies of the frequency spectrum scan along with an electronic copy of this information. The ENGINEER will approve final locations of antennas and any necessary repeater stations. Install an antenna splitter cable at locations where it is determined that a dual antenna configuration is necessary to accommodate communications in multiple directions.

1.3.2 Antenna

Install the antenna in such a manner that avoids conflicts with other utilities (separation distances in accordance with the guidelines of the NESC) and as specified in the antenna manufacturer's recommendations. Secure the antenna mounting hardware to the pole and route the coaxial cable such that no strain is placed on the N-Type coaxial connectors. On wood pole installations, bond the antenna mounting hardware to the pole ground using # 6 AWG bare copper wire using split bolt or compression type fitting.

1.3.3 Cable

Install the coaxial cable shield grounding system by carefully removing the outer jacket of the coaxial cable without damaging the cable shield. Install the shield grounding system following the cable manufacturer's recommendations. Install and weatherproof the connection using the appropriate weatherproofing materials and following the manufacturer's recommendations. On wood poles, secure the #6 AWG grounding lead cable to the pole ground using split bolt or compression type fitting or an approved method. On metal poles, secure the #6 AWG grounding lead cable to the pole using an approved method.

1.3.4 Polyphaser

Do not exceed the 1-inch bend radius of the coaxial cable as it traverses from the cabinet to the antenna assembly. Connect the lightning arrestor to the coaxial cable in the equipment cabinet. Properly ground and secure the arrestor in the cabinet. Permanently label all cables entering the cabinet. Ensure the power supply for the radio system is **NOT** connected to the GFCI receptacle circuit located in the cabinet. Place a copy of all manufacturer equipment specifications and instruction and maintenance manuals in the equipment cabinet.

At certain locations it may be necessary to integrate the radio system with a fiber optic system. Follow the details shown in the fiber optic splice plans.

1.4 Measurement

Furnish and Install Spread Spectrum Radio Assembly shall be measured as EACH unit.

Install Antenna and Antenna Coaxial Cable shall be measured as EACH unit.

1.5 Payment

Furnishing and installing Spread Spectrum Radio Assemblies including Antenna and Cable, accepted and measured as described above, will be paid at the contract unit price bid for:

6770489	FURNISH & INSTALL SPREADSPECTRUM RADIO ASSEMBLY WITH YAGI ANTENNA (LOCAL)	EA
6886071	INSTALL SPREADSPECTRUM RADIO ASSEMBLY WITH YAGI ANTENNA (LOCAL)	EA
6770490	FURNISH & INSTALL SPREADSPECTRUM RADIO ASSEMBLY WITH OMNI DIRECTIOAL ANTENNA (MASTER)	EA
6886072	INSTALL SPREADSPECTRUM RADIO ASSEMBLY WITH OMNI DIRECTIOAL ANTENNA (MASTER)	EA
6770491	FURNISH & INSTALL SPREADSPECTRUM RADIO REPEATER ASSEMBLY	EA
6886073	INSTALL SPREADSPECTRUM RADIO REPEATER ASSEMBLY	EA
677048A	FURNISH & INSTALL ANTENNA AND ANTENNA COAXIAL CABLE	EA
6886070	INSTALL ANTENNA AND ANTENNA COAXIAL CABLE	EA

Such payment shall be full compensation for furnishing radios, antennas, cables, switches, lightning arrestor, and all materials, equipment, labor, and incidentals to complete the work as specified.

Pay Item Notes

This specification is not limited to these pay items. Other pay items may be applicable.

678.1 DETECTOR LOOP

1.1 Description

This work shall consist of installing and/or furnishing a Detector Loop within and alongside the roadway, at the locations shown on the Plans, and in accordance with these Specifications. A Detector Loop installation shall consist of: installing the required conduit runs; making the pavement saw cut; placing the required number of turns of loop wire in the saw cut; creating a twisted pigtail; splicing the pigtail to the shielded, twisted pair lead-in cable; connecting the lead-in cable to the back-panel terminals at the controller cabinet; verifying proper detection of traffic; and sealing the saw cut. Several items used to create a complete detector installation are specified elsewhere. They are: FURNISH AND INSTALL ELECTRICAL CONDUIT; and FURNISH AND INSTALL SPLICE BOXES/ JUNCTION BOXES. The "junction point" referred to in the specifications below, is defined to be a splice box, or a conduit junction box as specified on the Plans.

1.2 Materials

Acceptable materials can be found on the current SCDOT Qualified Products List. Product Specifications for acceptable materials are located at http://www.scdot.org/doing/publications_Traffic.aspx

1.3 Construction

1.3.1 Saw Cuts

The LOCATION and SIZE of each loop shall conform to the Plans and to the Standards. In general, the front of each loop shall be located 12 to 36 inches in front of the Stop Line, however, the final location will be determined by the ENGINEER or as shown on the Plans. Location of loop should be verified before cutting.

Loops shall be centered in the traffic lane to be detected or as shown on the Plans.

All presence loops, left turn lanes and side streets, shall be cut in a quadrupole design. This will be a minimum of a 6 foot by 30 foot loop with a cut down the center 30 foot long.

Prior to cutting, the intended saw cut shall be carefully (using paint or chalk) marked on the pavement and approved by the ENGINEER.

The Contractor shall slot the roadway using a diamond or abrasive rotary power-saw with a blade approximately 3/8 INCH IN WIDTH. The saw shall a power-driven walk-along model, not a hand-tool.

The MINIMUM DEPTH of each Saw cut shall be:
2 INCHES DEEP in CONCRETE; and
2-1/2 INCHES DEEP in BITUMINOUS pavement; and
3 INCHES DEEP for any Quadrupole loop or loop with 4 turns.

The corner treatment of the saw cut shall prevent sharp edges. Saw cuts shall be extended to provide full-depth. All corners, where loop wires turn, shall be diagonal cut.

Saw cuts shall be washed out, blown dry, and shall be free from dust, grit, oil and moisture before the placement of wire. Compressed air shall be used to blow dry.

Saw cutting of curb and gutter shall be permitted with ENGINEER written approval. If saw cutting of curb and gutter is not permitted, a 1 ½ inch hole shall be drilled under the curb at a 45 degree angle."

Pavement seams or cracks should be avoided. However, when it is necessary to traverse a crack, a 2 inch diameter hole at least 3 inches deep should be drilled, and slack provided in the loop wire to allow for expansion and contraction.

Loop installation shall be staged so that each entire loop installation (from saw cut to sealing) is completed within the same working day with minimum blockage of traffic.

1.3.2 Loop Wire

Each loop wire shall be continuous and splice-free. Further, any wire with cuts, breaks, or nicks in the insulation shall not be accepted. All loops shall be wired in one direction, this will be a counter-clock-wise direction.

Each loop shall have the number of Turns shown in the table below, or as shown on the Plans.

SIZE	NUMBER OF TURNS
6 x 6 feet	4
6 x 10 feet	4
6 x 15 feet	3
6 x 20 feet	3
6 x 30 feet	3
6 x 30 feet (Quadrupole)	2 figure-eight turns (2 loops on the outside and 4 loops in the center cut)
6 x 40 feet	2
6 x 50 feet	2
10 x 20 feet	3
10 x 30 feet	3
10 x 40 feet	2
OTHER SIZES	AS PER PLANS

Each Detector Loop shall be formed by installing in a separate saw cut, 1 continuous length of single conductor wire, from the nearest approved "junction point", around the loop the specified number of turns, then back to the "junction point".

The "pigtail" from the corner of the loop, formed by the two ends of the loop wire, shall be twisted together with a pitch of 15 TURNS PER YARD, between the "junction point" and the loop itself.

The wire shall be pressed to the bottom of the saw cut slot. A roller or a blunt-stick (similar to a paint stirrer), shall be used to seat the loop wire at the bottom of the slot or channel. In no case shall a screw driver or similar sharp tool be used for this purpose.

The wire shall be laid in the slot so that there are no kinks or curls, and no straining or stretching of the insulation around the corner of the slot, or at the junction.

After placing the wire in the slot, it shall be rechecked for slack, raised portions, and tightness.

1 INCH LENGTHS of 1/2 inch closed-cell foam-plastic (BACKER-ROD) shall be used at 2 foot spacings, to hold the wire at the bottom of the slot. DO NOT use backer-rod around the entire perimeter!

The loop wire pigtail should be enclosed in conduit from the roadway edge to the "junction point".

Each loop shall be TESTED BEFORE SEALING. The inductance shall be in the range of 50 to 2500 micro-Henrys. The insulation resistance measured to earth ground shall be greater than 100 megohms at 500 volts DC.

Note: MEGGER TEST and INDUCTANCE TEST REQUIRED before and after sealing. A written record of the test shall be submitted to the ENGINEER on company letterhead.

1.3.3 Lead-In Cable

The lead-in cable shall be continuous, splice-free, and free from cuts or nicks in the insulation.

At the specified "junction point", the twisted "pigtail" from the loop wire shall be spliced to the shielded, (twisted-pair) lead-in cable that runs from the "junction point" to the controller cabinet (terminal). Each loop lead in wire shall be spliced and wrapped independently from the other loop lead in wires.

The "junction point" splice shall be electrically permanent and sealed waterproof. 1-1/2 inches of insulation shall be removed from each wire. The splice shall be either crimped-on, -or- twisted and soldered. The entire splice shall then be sealed waterproof using a method described below. The ENGINEER must be present to witness these acts. Any splices made without the presence of the ENGINEER are unacceptable, and shall be re-spliced. The methods of waterproof sealing are:

- a) Normal Splice - Each individual splice (pair of twisted loop wires meeting pair of loop lead-in wires), shall be performed by using either a crimp-on or a soldered joint. The junctions shall then be sealed in a low-voltage, waterproof splice kit. The splice kit shall be installed per the manufacturer's instructions.
- b) Underwater Splice - Where required on the Plans an underwater splice kit shall be installed according to the manufacturer's instructions.

Sufficient slack shall be left in both the lead-in cable and the loop wire, so that the splice may be moved 3 feet from the front of the "junction point". The slack shall be neatly coiled and nylon-tied after completion of the splice.

In the controller cabinet, the lead-in cable shall be uniquely identified by an insulated, preprinted-sleeve, slipped over the wire before attachment of a spade-lug connector. A spade-lug connector shall be crimped onto each loop lead-in wire.

In the controller cabinet, the ground (drain) wire from each lead-in cable shall not be connected. Rather it shall be cut-off at the cable sheath, and left floating.

Unless otherwise specified, the lead-in cable shall be enclosed in conduit from the "junction point" to the nearest signal pole, or directly to the controller if it is on the same corner. The conduit for lead-in cable required to be installed under sidewalks and curbs may be aluminum, galvanized, PVC 80, or flex PVC. The cable shall then run: up inside a conduit or metal pole, across span wires, and then down inside a conduit or metal pole, to the controller.

1.3.4 Sealant

Sealant is used in all loops unless specified by the ENGINEER.

The Department approved Loop Sealant shall be mixed and applied according to the manufacturer's directions.

The sealant shall not be poured into saw cuts during weather conditions of precipitation of any kind, or at temperatures below 10° C (50° F).

The saw cut and drilled holes shall be completely filled with sealant, allowing no bubbles below the surface and only a minimum spill-over along the joint. Duct-Seal shall be used to prevent sealant from flowing into conduit ends.

When the sealant hardens, there shall be neither a bulge nor depression, but rather a smooth road surface. The sealant shall not be over-poured so there is a bulge or bump higher than the surrounding surface of the roadway. It shall be wiped smooth with a squeegee.

The Contractor should make sure that the sealant has hardened before allowing traffic to move over the area.

1.3.5 Warranty

The CONTRACTOR shall guarantee the loops for workmanship for 5 years following approval of project. The CONTRACTOR will return to repair or replace any loops rising up or pulling from the pavement or not functioning within warranty period at no additional cost.

1.4 Measurement

Detector loops shall be measured by LINEAR FEET of: loop wire, lead-in cable, and saw cut as actually placed, including sealant, electrical connections, testing, and incidental hardware. Note that conduit and vehicle detector amplifiers are measured elsewhere as separate items.

1.5 Payment

Detector loops, measured as provided above, shall be paid for at the contract unit price bid for:

Loop Wire:

6770413	FURNISH & INSTALL NO. 14 COPPER WIRE, 1-CONDUCTOR FOR LOOP WIRE	LF
---------	---	----

Loop Lead-in cable:

See 677.1 Electrical Cable

6770389	FURNISH & INSTALL NO. 14 COPPER WIRE, 4 CONDUCTOR - GRAY	LF
6770394	FURNISH & INSTALL NO. 14 COPPER WIRE, 8 CONDUCTOR - GRAY	LF

Saw Cut:

6780495	SAWCUT FOR LOOP DETECTOR	LF
---------	--------------------------	----

and such payment shall be full compensation for furnishing all materials, equipment, labor, and for all testing, details and incidentals necessary to provide proper vehicle detection, complete in place as specified.

Pay Item Notes

This specification is not limited to these pay items. Other pay items may be applicable.

LOOP DETECTOR INSPECTION REPORT							
LOCATION: DESCRIPTION:				DATE: BY:			
LOOP POSITION		BEFORE SEALING			AFTER SEALING		
APPROACH	LANE	f kHz	L μh	R MΩ	f kHz	L μh	R MΩ

COMMENTS

NOTE: L SHALL BE 50 -2500 μh; R SHALL BE >100 MΩ @ 500 VDC

SUBMITTED BY	DATE	CHECKED BY	DATE	APPROVED BY	DATE
IN SERVICE BY	DATE	TIME	CHECKED BY	DATE	TIME

680.1 ELECTRIC SERVICE

1.1 Description

This work shall consist of installing and/or furnishing an Electric Service to provide electric power to traffic signals, at locations shown on the Plans, and in accordance with Power Company procedures.

1.1.1 Standards

All work is to be in accordance with the signal Installation Details, the Standards, or the REQUIREMENTS OF THE LOCAL POWER COMPANY. All work shall be in accordance with the National Electric Code (NEC), and applicable local Codes.

1.1.2 Meetings

The resident construction engineer or ENGINEER, the CONTRACTOR, and the Power Company Representative shall discuss the project at the "Pre-Construction Meeting", and arrange the schedule for power connection. Additional meetings will be held as necessary to satisfy all concerns about Electrical Service.

1.1.3 Representative

For the name and address of the local utility company:
SCDOT Utility Engineer
Room 424
955 Park Street
Columbia, SC 29202
(803)-737-1296

1.1.4 Schedule

The CONTRACTOR shall make all necessary arrangements with the Power Company to insure having the needed power available at the TIME OF SIGNAL TURN-ON. Difficulties in securing the service of the Power Company are to be immediately reported to the Engineer.

1.1.5 Location -

The CONTRACTOR shall determine the exact location of the electric service. The nature of the service is shown on the Plans, but shall also be finalized as:

- a) Overhead service drop to controller pole;
- b) Overhead service drop to service pole, then underground to controller cabinet (isolated); or
- c) Underground Power Company feed, to service on the back of controller cabinet.

1.1.6 Meter

The electric service will usually be METERED. The CONTRACTOR shall provide hardware accordingly.

1.2 Materials

The power connection shall be a SINGLE-PHASE, 120/240 VOLT, 3-WIRE, 60 Hertz alternating current supply.

1.2.7 Meter

The CONTRACTOR shall furnish and install the METER BOX (PAN), and the HUB.

1.2.8 Disconnect Switch

The disconnect switch shall be NEMA STANDARD TYPE 3R, weatherproof. It shall be CIRCUIT BREAKER TYPE, and have a tab for pad-locking the cover closed. It shall be of 3-WIRE DESIGN (2-circuit), with solid neutral. The CONTRACTOR shall twist a No. 6 AWG wire through the padlock tab, to prevent unauthorized entry (until the District installs their own padlock).

1.2.9 Rating

To provide a maximum of future flexibility, and a minimum of voltage-drop to the lamps, the components of the electrical service shall have the ratings stated in the following table:

<u>ITEM</u>	<u>USAGE</u>	
	<u>Flashing Beacons</u>	<u>Traffic Signal</u>
Disconnect Breaker		
Box Rating (for uniformity):	60 AMP	60 AMP
Circuit Breaker (one side):	20 AMP	50 AMP
Cable		
3-Wire (W, BL, RD), THHN/THWN	No.6 AWG	No.6 AWG
Conduit		
Schedule 80 PVC	1 inch	1 inch

1.2.10 Ground Rod

One or more ground rods shall be installed at the service pole; and where applicable, at the controller cabinet itself.

The ground rod shall be 16 mm by 5/8 inch by 8 feet (minimum), copper-clad, with brass or bronze ground rod clamp. The controller ground rod shall be EXOTHERMICALLY WELDED.

1.2.11 Ground Wire

The grounding wire for the service shall be No. 6 AWG, Bare, solid or stranded copper wire. (Note that this is in addition to the solid grounding wire running down each wooden pole.)

1.2.12 Conduit

Conduit and Fittings used for the Electric Service shall be PVC Schedule 80, 1 inch DIAMETER. It shall extend from the point of Power Company attachment, through the meter and disconnect assembly, to the controller cabinet.

See 675.1 ELECTRICAL CONDUIT.

1.2.13 Weatherhead

A weatherhead mating to the above conduit shall be used with overhead service connections. Also used shall be a strain Clevis, to create a 1 foot minimum drip loop.

1.2.14 Cable

The electrical cable installed from the point of Power Company attachment to the Controller Cabinet, shall be: Type THHN/THWN, sized per above table, 3-WIRE, (White, Black, red) 600 Volt, Copper only, stranded, with cable lugs. At no place shall the service cable be in the same conduit as signal cables or loop lead-ins.

1.2.15 Hardware

All hardware used shall be rustproof: steel parts shall be stainless steel or galvanized. STAINLESS STEEL BANDS shall be used for attachment to steel poles. The bands are to be spaced every 3 feet maximum, and at the top and bottom of the pole. When specifically required by the Utility Company or on wood poles, Conduit Clamps/strap, fastened with galvanized screws, may be substituted for the bands.

1.3 Construction

The Electrical Service shall be installed in accordance with all applicable Codes, Regulations, and the REQUIREMENTS OF THE POWER COMPANY, with the final location being determined in the field. Typical construction methods are shown on the Installation Details, and the Standards.

The CONTRACTOR shall obtain all ELECTRIC PERMITS required; and shall arrange for INSPECTION at completion.

1.3.16 Equipment Power

1.3.16.1 Normal

The Type 170 Power Supplies with additional cabinet surge protection, for equipment for this Contract, (while operating from a 115 VAC, $\pm 10\%$, Sixty (60) Hertz, commercial grade, non-dedicated power service), shall be capable of providing the following:

Proper regulation for AC outputs, up to one-hundred and fifty (150%) percent of normal load.

Sufficient internal electronic noise and transient immunity, so that equipment fed by this service will not be effected by either noise or transients.

Equipment power supplies of sufficient design to prevent extraneous coupling of signals between equipment.

Complete internal surge protection (in addition to that of the Controller Cabinet).

1.3.16.2 Additional

Where electronic problems can be traced to Radio Frequency Interference (RFI), as shown by an oscilloscope, then the CONTRACTOR shall provide additional isolation, filters, capacitors, etc. to eliminate the problem.

1.3.17 Ground System

The resistivity of the electrical system EARTH GROUND shall be 15 OHMS OR LESS, as measured with an appropriate instrument which was calibrated not more than 60 days prior to the date of performing such tests. The poles, ground rods, ground wires, span wires, etc. forming the traffic signal,

are intended to form a "GROUNDING ELECTRODE SYSTEM" as defined by Article 250 of the NATIONAL ELECTRIC CODE.

1.4 Measurement

Complete Electrical Service shall be measured by EACH service installed in place, as shown on the Plans. It shall include all necessary conduit (trenched and/or riser), cable, conduit fittings, hardware, ground rod, banding, clamps, lugs, and all other materials and equipment specified or directed by the ENGINEER or Power Company. (Usually, there shall be no additional measurement of electrical cable used; there shall be no additional measurement of conduit used.) When an "Isolated electric service" is required by the Plans, an item and quantity will have been provided for wooden pole, as required.

1.5 Payment

Complete Electrical Service, inspected, accepted, and measured as above, shall be paid for at the Contract Unit bid for

6800499	FURNISH & INSTALL ELECTRICAL SERVICE FOR TRAFFIC SIGNAL	EA
6800500	MODIFY EXISTING ELECTRICAL SERVICE FOR TRAFFIC SIGNAL	EA

which shall be full compensation for furnishing riser, meter, disconnect switch, and all materials, equipment, labor, and incidentals to complete the work as specified.

Pay Item Notes

This specification is not limited to these pay items. Other pay items may be applicable.

680.2 SPLICE BOX / JUNCTION BOX

1.1 Description

This work shall consist of installing and/or furnishing a Splice Box or Junction Box at the locations shown on the Plans in accordance with these specifications. The Splice Box shall consist of a Box and Cover, installed over aggregate. The Splice Box is intended for use as a signal cable electrical enclosure. The Junction Box is intended for use as a loop detector "junction point". Unless shown mounted on a pole, it shall be installed in the dirt, at the depth of the conduit run, and covered with earth.

1.2 Materials

Acceptable materials can be found on the current SCDOT Qualified Products List. Product Specifications for acceptable materials are located at http://www.scdot.org/doing/publications_Traffic.aspx

1.3 Construction

1.3.1 Splice Box

The Splice Box shall be constructed as indicated in the Design Details or the Standards, at locations shown on the Plans.

The Splice Box shall be constructed such that when the Box and Cover are in place, they are flush with the adjacent pavement, ground, or sidewalk, as shown in the Design Details or the Standards. Patching Concrete shall be placed around any Box installed in pavement.

Boxes shall be placed at least 1 foot behind the curb-line or edge of roadway or as shown on the plans.

Placed Before Pouring. Where shown on the Plans, Custom Splice Boxes shall be placed in roadways or structures, prior to pouring the concrete. Typical usage would be in a bridge deck. The incoming conduit shall be firmly attached to the bottom reinforcement bar mat, or to the bottom wire-mat, using plastic tie-wraps every 2 feet. CAUTION: THE BOTTOM OF THE SPLICE BOX AND THE CONDUIT ENDS ETC. SHALL BE COMPLETELY PLUGGED/BLOCKED/SEALED TO PREVENT CONCRETE PENETRATION. When used on a bridge, the Splice Boxes will be near the center line, and the conduit will terminate in Splice Boxes at each end.

1.3.2 Conduit

See 675.1 ELECTRICAL CONDUIT.

Conduit shall enter the Box at the bottom and extend at least 2 inch beyond the inside wall.

Conduit shall enter from the direction of the run unless otherwise permitted by the ENGINEER.

All metallic conduit ends within the Box shall have grounding bushings with plastic inserts; and shall be bonded with one another with #6 AWG bare copper ground wire. Plastic conduits shall have end bushings to prevent chaffing.

After the electrical cable is placed, the completed conduit ends shall be packed with "duct-seal" or other equivalent material to prevent water from entering the conduit. Spare conduit shall be capped.

1.4 Measurement

Furnishing and installing Splice Boxes will be measured by EACH Box placed complete, including Box, Cover, aggregate, patching concrete, ground wire, ground bushings, sealing, and all miscellaneous hardware and incidentals required.

Furnishing and installing Junction Boxes will be measured incidental to the conduit to which it is used with.

1.5 Payment

Furnishing and installing Splice Boxes / Hand Boxes, accepted and measured as provided above, will be paid for at the contract unit price bid for:

*6800518	FURNISH & INSTALL 13"X24"X18"D.ELEC.FLUSH UNDGRD.ENCLOSURE-(STR.POLY.CONC.)HD	EA
680052C	FURNISH & INSTALL 17"X30"X24"D.ELEC.FLUSH UNDGRD.ENCLOSURE-(STR.POLY.CONC.)HD	EA
6800508	FURNISH & INSTALL 12"X12"X12"D.ELEC.FLUSH UNDGRD.ENCLOSURE-(STR.POLY.CONC.)HD	EA
6888100	INSTALL ELECTRICAL FLUSH UNDERGROUND ENCLOSURE	EA

which shall be full compensation for furnishing all materials, equipment, labor, and incidentals necessary to complete the work as specified.

Pay Item Notes

* typically used by SCDOT

This specification is not limited to these pay items. Other pay items may be applicable.

682.1 WOOD POLE

1.1 Description

This work shall consist of installing and/or furnishing CCA treated Wood Poles, of the types and sizes shown on the Plans, in accordance with these Specifications, and in close conformity with the lines shown on the Plans, or as established by the ENGINEER. Each wood pole installation shall include all related overhead and underground hardware, and back guy assemblies as provided elsewhere.

1.2 Materials

1.2.1 Wood Pole

1.2.1.1 Wood

Each pole shall be Southern Yellow Pine that is cut, stored, seasoned, and manufactured in accordance with specification ANSI 05, 1-19-79. Prohibited defects include: red heart, shakes in the tops of poles, short crooks, double-sweep, splits or through-checks, nails & spikes, and excessive knots. Scars shall not be deeper than 1 inch, nor longer than 3 feet. Poles shall not have excessive butt-swell, nor more than one twist per pole length. Sweep in two planes is prohibited.

1.2.1.2 Straightness

All poles shall be straight to the extent that a line drawn from the center of the butt end, to the center of the tip end shall lie within the middle two-thirds of the body of the pole at all points. Poles shall also be free from short crooks, in which the surface deviation from straightness in any 5 feet of length, exceeds 1.5 inches at any location, as determined by a straight edge.

1.2.1.3 Treatment

Each pole shall be prepared and pressure-treated in accordance with American Wood Preservers Association (AWPA) Standards C1, C3, C4, and M1. Treatment shall be "SALT TREATED", CCA-CHROMATED COPPER ARSENATE, and shall conform to AWPA Standard P5. The retention of the treatment shall be tested in accordance with AWPA Standard M2. The minimum penetration shall be 3 inches, or 90 percent of the sap-wood. The retention shall be at least 0.60 POUNDS PER CUBIC FOOT, as determined by AWPA Standards.

1.2.1.4 Size

Each pole shall be Class II or Class III. The length shall be either 35 feet, 40 feet, or 45 feet.

1.2.1.5 Brand

Each pole shall have a "brand" 12 feet above the butt-end, showing the Manufacturer. Plant-location with month and year of treatment, "Southern Pine CCA", and the Pole Class and Length. A Metal Tag showing Pole Length and Class shall be fixed to the butt-end; and the Length and Class shall be stamped on the top-end.

1.2.1.6 Inspection

Each pole shall have the "Brand Mark" of an inspection-company that has been approved by the Department.

1.2.2 Back-Guy Anchor

Wood Poles for traffic signal usage, require the installation of one-or-more back-guy cable assemblies, as needed. (See FURNISH AND INSTALL BACK-GUY.) The installation shall be made in accordance with the Installation Details, or the Standards.

1.2.3 Ground Wire

Each pole shall be grounded in accordance with the Installation Details or the Standards. A No. 6 AWG, SOLID, bare-copper ground wire (ASTM B2) shall run the length of wooden poles, and extend 6 inches above the top end.

1.2.4 Ground Rod

The Ground Rod shall be copper-clad, conforming to EEI-TDJ-30, having a minimum size of 5/8 inch diameter by 8 feet in length. A ground rod clamp shall also be used (heavy duty bronze or brass).

1.3 Construction

1.3.1 Location

The general location of each pole is shown on the Plans. The Contractor shall determine the final location of the pole, which shall be approved by the ENGINEER. Consideration shall be given to the property lines, underground utilities, and overhead clearances (including the guy anchor assembly).

1.3.2 Hole

A hole shall be drilled 6 feet DEEP, or as shown on the Plans. The diameter shall be larger than the pole by approximately 4 inches all around. The hole shall be of uniform diameter, and cleanly augured.

1.3.3 Sidewalk

When the pole is installed in a side walk, then the hole shall be cleanly cut 6 inches larger than the pole on all sides. After installation of the pole, and back filling the hole, then expansion joint material shall be placed around the pole, and tacked in place. Conduit running to the pole shall be installed at this time, in the cut. Concrete shall be poured around the pole to a depth of 10 cm (4 inches) and neatly troweled level. This work shall be considered incidental to pole installation, unless a pay item has been established for concrete patching or side walk.

1.3.4 Installation

Poles shall be vertical, except at corners, where they shall be RAKED away from the strain, 2 to 4 inches per 10 feet length. Back guy assemblies shall be installed in line with the strain of each span wire. After installing, the hole shall be back-filled with clean earth or sand (no rocks or debris), placed in 1 foot layers; each layer moistened and compacted. Excess earth shall be removed from the site. (A 2 inch mound around the pole base is acceptable.)

1.3.5 Utility Poles

Where poles are to be used for joint-use UTILITIES, they shall be installed in accordance with all local codes, and with the requirements of the Utility Company. Cross Arms shall be provided if required by the Utility Company.

1.3.6 Grounding

Each pole shall have a No. 6 Bare SOLID copper ground wire running the entire length. The ground wire shall be securely attached and bonded while the wood pole is laying on the ground. It shall extend 6 inches above the top end, have a 2 foot coil (slack) at the top end, and extend down to the bottom, and have another 2 foot coil on the bottom end. The ground wire (and the coils) shall be attached using galvanized 1-1/2 inch wire staples, on (2 foot) centers above 14 feet, and on 1 foot centers below 14 feet. (The spacing change will be at 8 feet above grade.)

1.3.7 Ground Rod

One wood pole at each intersection shall have a GROUND ROD. Usually this would be the pole having the electrical service from the Power Company. The ground rod shall be driven vertically into the earth, until it extends about 2 inches above local grade. Then a separate No. 6 AWG bare, STRANDED/SOLID copper wire shall be used to bond the electrical service and the overhead cable (and pole ground wire) system to the ground rod, using a grounding clamp.

1.3.8 Back Guying

Each wood pole that is used to support signal span wires, shall be back guyed. Wood poles used to support messenger cables could require back guying, especially at turns. (See FURNISH AND INSTALL BACK GUY.) It is the responsibility of the Contractor to install sufficient numbers of back guy assemblies, to insure the stability of wood pole installations. This may include: double-guying; extra-large anchors; or Re-guying Utility Company poles. A quantity for "Back Guy" has been established in the Bid or Proposal. The Contractor shall inform the ENGINEER when additional back guy assemblies are required. When the back guy is installed in a side walk, then the procedures of paragraph 2.3 above shall be followed.

1.3.9 Acceptance

Acceptance of each wood pole shall include checking for the pressure-treatment inspection company Brand Mark, plus visual inspection by the ENGINEER. The visual inspection shall be made of the pole, overhead cables, grounding, and back guy assembly. The complete installation shall be structurally sound, and the final pole placement shall be vertical, or raked as specified. Poles NOT meeting this inspection shall be replaced by the Contractor, without further cost to the project.

1.4 Measurement

Furnishing and installing wood poles, will be measured by EACH, of the Size specified, erected in place as shown on the Plans, including grounding, and all miscellaneous hardware and related work activity as required.

1.5 Payment

Furnishing and installing wood poles, accepted, and measured as above, will be paid for at the contract unit price bid for:

6825020	FURNISH & INSTALL 35' WOOD POLE - CLASS II - CCA TREATED(0.60)	EA
6825021	FURNISH & INSTALL 40' WOOD POLE - CLASS II - CCA TREATED(0.60)	EA
6825023	FURNISH & INSTALL 50' WOOD POLE - CLASS II - CCA TREATED(0.60)	EA
6825025	FURNISH & INSTALL 60' WOOD POLE - CLASS II - CCA TREATED(0.60)	EA
6888150	INSTALL WOOD POLE	EA

which shall be full compensation for furnishing all materials, equipment, labor, and incidentals necessary to complete the work as specified.

Pay Item Notes

This specification is not limited to these pay items. Other pay items may be applicable.

682.2 BACK GUY

1.1 Description

This work shall consist of installing and/or furnishing Back-Guy cable assemblies to secure wood poles, at locations shown on the Plans, and in accordance with these Specifications, and the Installation Details and Standards.

It is the responsibility of the CONTRACTOR to assure that the number and size of Back-Guy assemblies is fully sufficient to anchor every wood signal pole, corner messenger cable pole, and Utility Company pole (where required).

1.2 Materials

1.2.1 Assembly

From the top-down, a Back-Guy Assembly shall consist of: eye-type thru-bolt, guy-hook, strandvise (or 3-bolt clamp), jumper-bonding clamp, the steel cable (3/8-inch guy-cable stranded), another strandvise (or 3-bolt clamp), and a Screw-type guy anchor.

1.2.2 Rust Proof

All parts shall be as shown on the Installation Details or the Standards. All hardware shall be hot-dip galvanized in accordance with ASTM Standard A-153.

1.2.3 Parts List

Acceptable parts are listed below:

- a) Guy Anchors - One piece screw type guy-anchors, shall conform to EEI-TD-2, 1 inch diameter, 8 FEET LONG, thimble eye type. (Joslyn No. J-6550-WCA or approved equal)
- b) Guy Guards shall conform to REA Item "AT" yellow plastic (PVC) sunlight resistant, 8 feet long.
- c) Spool Insulators shall conform to REA Item "CM".
- d) Insulators shall conform to REA Item "W".
- e) Machine Bolts shall conform to REA Item "C".
- f) `J' hooks shall be Reliable No. 5552 (or approved equal).
- g) Reliable Universal Strandvise (or approved equal) shall be used for guy and messenger cable deadends.
- h) Thimbleye Bolts shall conform to EEI-TD-4.
- i) Thimble Nuts shall conform to EEI-TDJ-5.
- j) Washers shall conform to EEI-TDJ-10.
- k) Angle Thimbleye shall conform to REA Item 5.
- l) Cable- SEE FURNISH & INSTALL STEEL CABLE; using the 3/8 INCH DIAMETER CABLE SIZE.
- m) Cable Clamps: 3-bolt clamps shall conform to EEI-TDJ-23, (4 inch and 6 inch sizes)
- n) Clevises shall conform to EEI-TD-20.
- o) Side-walk Bridge-over shall be a stress supporting spreader-type, bolting to the wood pole.

1.3 Construction

A Back-Guy Assembly shall be installed:

- a) Where shown on the plans;
- b) In conjunction with installation of Steel Cable as span wire;
- c) In conjunction with the installation of a wooden pole;
- d) Where required by the Utility Company to "dress" pole to which signal equipment is attached; or,
- e) At corner/turning wood poles that are used for messenger cable runs.

The installation of the wood pole, Back-Guy Assembly, and the span wire, shall have the construction staged for the safety of the motorist, pedestrian, and signal construction worker.

See 682.1 WOOD POLE.

The span wire and Back-Guy Assembly shall be stretched, adjusted, and then RE-ADJUSTED to produce the specified amount of span wire sag, the proper signal head road-clearance, and still create a nearly vertical wood pole.

The CONTRACTOR shall assure that the Back-Guy Assembly is sufficiently strong to handle the pull of all span wires. This shall include consideration of the earth/soil type into which the ground anchor is buried. The CONTRACTOR shall furnish EXTRA LARGE ANCHORS and/or MULTIPLE-ANCHOR ASSEMBLIES if needed. Special anchors shall be used for solid rock.

Where a pedestrian sidewalk is adjacent to a wood pole, the CONTRACTOR shall furnish as an incidental item, a sidewalk "bridge-over" assembly.

The compass angle of the Back-Guy shall be reasonably IN LINE with the strain of the overhead cable: that is, in line with each span wire. Thus most signal poles should have two (2) Back-Guys, installed at right angles to each other. The use of a single diagonal Back-Guy is generally unacceptable.

The Back-Guy shall be installed (wherever possible) to provide as a minimum: rise=2 / run=1 (i.e. 2/1). For example, if the Back-Guy is attached at 26 feet, the anchor should be at a minimum of 13 feet from the pole. This corresponds to an angle with the earth of about 60 degrees.

All work shall be performed within the public Right of Way, and particular care shall be taken to assure that the Back-Guy does not extend into private property.

The Back-Guy shall be installed where it will not interfere with traffic, giving particular attention to private driveways. Where damage is likely (e.g. edge of driveway) then a STEEL GUY GUARD shall be installed to protect the cable. When shown on the Plans, a CONCRETE TIRE/WHEEL STOP (curb) shall be placed at the base of the Back-Guy, anchored/pinned with 2 feet pieces of reinforcement bar.

NO splices shall be allowed in the steel cable.

1.3.3.1 Inspection

The ENGINEER shall inspect each installation of wood pole, span wire, signal heads, and Back-Guy, for proper clearance, dress, and tension. At the direction of the ENGINEER, the CONTRACTOR shall re-install or replace improper installations, without further compensation.

1.4 Measurement

Furnishing and installing Back-Guy Assemblies, will be measured by EACH, erected in place in accordance with the Specifications and as shown on the Plans, including all miscellaneous hardware as required.

Additional Back-Guy Assemblies that are installed for reason of situations or conditions that arise during construction, will be paid, and shall be measured by EACH.

1.5 Payment

Furnishing and installing Back-Guy Assemblies, accepted, and measured as above, will be paid for at the contract unit price bid

6825045	FURNISH & INSTALL 3/8" BACK GUY FOR WOOD POLE	EA
6825046	FURNISH & INSTALL 3/8" SIDEWALK GUY	EA
6825047	FURNISH & INSTALL 3/8" AERIAL GUY	EA

which shall be full compensation for furnishing all materials, equipment, labor, and incidentals necessary to complete the work as specified.

Pay Item Notes

This specification is not limited to these pay items. Other pay items may be applicable.

682.3 STEEL CABLE

1.1 Description

This work shall consist of installing and/or furnishing splice-free lengths of Steel Cable with cable supports, for mounting signal heads, signs, interconnect runs, installing back guys, etc., at locations shown on the Plans or as established by the ENGINEER.

1.2 Materials

Acceptable materials can be found on the current SCDOT Qualified Products List. Product Specifications for acceptable materials are located at http://www.scdot.org/doing/publications_Traffic.aspx

1.3 Construction

1.3.1 Span Wire

All Span Wire shall be installed as shown the Standards, or on the Construction and Installation Details. Note that different methods and materials are required for Wood Poles and Steel Poles.

Before erecting the Span Wire, the Contractor shall determine the length of cable required to span the distance indicated on the Plans. Sufficient additional length shall be allowed to compensate for sag, pole connections, and adjustments, to make the whole assembly consistent with the Design Details, or the Standards. NO MID-SPAN SPLICES SHALL BE PERMITTED.

The Contractor shall set the Span Wire so that the height of the installed signal heads, including all hardware, shall conform to the clearances shown on the Design Details or the Standards, or as directed by the ENGINEER.

The Span Wire shall not be permanently "tied-off" until all signal heads, signs, and cables are in place.

The Contractor shall not erect any Span Wire which lays on, or is likely to rub a Utility Company's cable. If a Span Wire, as erected, is within 6 inches of any other cable, wire, or structure, it shall be protected with plastic wire-guards.

When required by the Utility Company, or by the applicable electrical Code, strain-type fiberglass insulators shall be installed.

Cables from STEEL POLES

- a) Steel Poles are essentially electrical conductors.
- b) A Roller Type Pole Clamp shall be used, attached at the proper height.
- c) The free-end of the cable shall be secured with a 6 inch galvanized steel clamp, with 5/8 inch galvanized bolts. The clamp shall be placed approximately 1 foot from the pole. Cable-grips are not permitted.
- d) The ends of the cable shall be covered with "servisleaves" to prevent unraveling.
- e) The SAG shall be 3%, TO 5%, fully loaded.

Cables from WOODEN POLES

- a) Wooden poles are essentially electrical insulators, and thus require extensive GROUNDING and BONDING procedures, as shown on the Construction and Installation Details, and the Standards.
- b) The SAG shall be typically 5%, fully loaded.
- c) The height of attachment shall be sufficient to provide the required road-clearance, including sag.
- d) Shall be installed in accordance with the requirements of the Utility Company.
- e) May require the installation of a back guy assembly as required in FURNISH AND INSTALL BACK GUY.
- f) Shall be electrically bonded.

1.3.1 Messenger Wire

Where Messenger Wire is attached to traffic signal poles, it shall be installed in the same manner as specified for span wire, but with relatively little sag.

Where Messenger Wire is attached to utility poles, it shall be installed in accordance with the UTILITY COMPANY'S SPECIFICATIONS.

1.3.2 Tether Wire

Where Steel Cable is specified to tether signal heads and/or traffic signs, it shall be installed as indicated on the Construction Details, or Standards. Generally, galvanized S-hooks should be used at the pole ends to permit "break-away" action.

1.3.3 Back Guy

See 682.1 WOOD POLE.

See 682.2 BACK GUY.

1.3.4 Cable Supports

Cable supports shall be used to support electrical cables from span wire and messenger wire. Cable Supports shall be spaced at 10 INCH INTERVALS.

When Aluminum Tie-Wraps are used, they shall be installed by wrapping 3-full turns TIGHTLY around the bundle formed by the steel cable and all electrical cables then cutting off from the tape coil.

1.4 Measurement

Steel Cable of the SIZE specified shall be measured by the LINEAR FEET of material as actually placed, which shall include cable supports, clamps, insulators, and all other miscellaneous hardware and fittings.

Steel Cable used for back guying, is included under 682.2 BACK GUY.

1.5 Payment

Accepted quantities of Steel Cable, measured as stated above will be paid for at the contract unit price bid for:

6825092	FURNISH & INSTALL 3/8" GALVANIZED STEEL CABLE	LF
6825090	FURNISH & INSTALL 1/4" GALVANIZED STEEL CABLE	LF

(or other sizes as shown on the plans), and such payment shall be full compensation for furnishing and placing the cable, support rings, clamps, S-hooks, turnbuckles, and other incidentals required to complete the work as specified.

Pay Item Notes

This specification is not limited to these pay items. Other pay items may be applicable.

682.4 PEDESTRIAN POLE AND BASE

1.1 Description

This work shall consist of installing and/or furnishing a Pedestrian Pedestal Pole and Base in accordance with these Specifications.

1.2 Materials

Acceptable materials can be found on the current SCDOT Qualified Products List. Product Specifications for acceptable materials are located at http://www.scdot.org/doing/publications_Traffic.aspx

1.3 Construction

1.3.1 Location

Pedestrian pedestal poles shall be installed where shown on the Plans or at other locations as directed or permitted by the ENGINEER.

1.3.2 Clearance

Pedestrian pedestal poles shall be mounted so that no portion of the assembly is closer than 18 inches to the face of the curb.

1.3.3 Concrete Foundation

The foundation shall be constructed to the dimensions shown on the Design Details or the Standards. Bolt "circle" data shall be in accordance with the recommendations of the base manufacturer. Suitable templates for setting anchor bolts shall be accurately set and left in place until the forms are removed.

Concrete shall be mixed, placed, and tested in accordance with applicable portions of SCDOT STANDARD SPECIFICATIONS Sections 701, 702, 703, and 704.

1.3.4 Anchor Bolts

Four Anchor Bolts shall be set using pre-formed templates (wood or metal), to provide a "bolt-circle" in accordance with the Dimension Chart, or with recommendations of the base manufacturer. The templates shall be left in place for two days (48 hours).

1.3.5 Conduit Elbows

Two 1 inch conduit elbows shall be capped at both ends and secured in place in the excavation before any concrete is poured. The size and number of elbows shall be that necessary to mate with the incoming runs.

All conduit elbows shall extend beyond the side of the finished foundation by approximately twelve inches, in the direction of, and at a depth matching the incoming conduit.

1.3.6 Mounting

The base shall be fastened to the concrete foundation using appropriate hardware. The aluminum pole shall be erected and screwed tightly into the base. The set screw will be tightened so to prevent counter rotation of the aluminum pole.

1.3.7 Powdercoating

Color to be specified in special provisions or on signal plan. Powdercoating over aluminum shall be done at the factory or during the manufacturing process.

1.4 Measurement

The furnishing and/or installing of a Pedestrian Pedestal Pole and Base shall be measured by EACH and includes concrete foundation and all required incidental hardware.

The furnishing and installing of a Pedestal Pole Concrete foundation shall be measured by EACH.

1.5 Payment

Furnishing and/or installing Pedestrian Pedestal Pole and Base measured as provided above, will be paid for at the contract unit price for

6825480	FURNISH & INSTALL 4' BREAK-AWAY ALUMINUM PEDESTAL POLE AND BASE	EA
6888188	INSTALL 4' BREAK-AWAY PEDESTRIAN PEDESTAL POLE AND BASE	EA
6825482	FURNISH & INSTALL 8' BREAK-AWAY ALUMINUM PEDESTAL POLE AND BASE	EA
6888189	INSTALL 8' BREAK-AWAY PEDESTRIAN PEDESTAL POLE AND BASE	EA
6825484	FURNISH & INSTALL 10' BREAK-AWAY ALUMINUM PEDESTAL POLE AND BASE	EA
6888190	INSTALL 10' BREAK-AWAY PEDESTRIAN PEDESTAL POLE AND BASE	EA
6888191	INSTALL BREAK-AWAY PEDESTRIAN PEDESTAL POLE ON EXISTING BASE	EA

Powdercoating Option:

6888192	POWDERCOATING OPTION FOR 4' ALUMINUM PEDESTAL POLE	EA
6888193	POWDERCOATING OPTION FOR 8' ALUMINUM PEDESTAL POLE	EA
6888194	POWDERCOATING OPTION FOR 10' ALUMINUM PEDESTAL POLE	EA

Foundation Only:

6825486	FURNISH & INSTALL ALUMINUM PEDESTAL POLE CONCRETE FOUNDATION	EA
---------	--	----

Such payment shall be full compensation for furnishing and installing the specified equipment, materials, labor, and incidentals to complete this item.

Pay Item Notes

This specification is not limited to these pay items. Other pay items may be applicable.

686.1 LED MODULES AND/OR POLYCARBONATE VEHICLE SIGNAL HEAD AND/OR BACKPLATE

1.1 Description

This work shall consist of installing and/or furnishing a LED Module and/or Polycarbonate Vehicle Signal Head and/or Backplate of the types, sizes, and mounting specified, in accordance with these Specifications. The signal modules shall maintain the pixilated appearance typical with earlier generations of LED's modules. Signal LED modules shall be designed to go dark after 40% of the LED's fail. The red section in the five section head shall be aluminum. All Signal Heads shall be supplied with the appropriate LED Modules installed and operational.

1.2 Materials

Acceptable materials can be found on the current SCDOT Qualified Products List. Product Specifications for acceptable materials are located at http://www.scdot.org/doing/publications_Traffic.aspx

1.3 Construction

1.3.1 Location

Polycarbonate vehicle signal heads shall be installed where shown on the plans, positioned according to the design details or the standards or at other locations as directed by the ENGINEER.

The top section of all vehicle signal heads mounted on the same pole or pedestal shall be within 6 inches of being the same height unless otherwise specified.

All multi-section/ combination signal heads shall be arranged with their top sections at the same elevation as other signal heads.

1.3.2 Clearance

Signal heads placed over the roadway shall be installed to provide a road clearance of 17 to 19 feet. This distance shall be measured from the pavement to the lowest part of the assembly.

1.3.3 Wiring

Electrical cable shall be connected to the terminals in each signal head to provide the proper display indication.

External splicing of cable is not permitted.

Electrical cable runs shall be as indicated in the specifications and on the plans.

1.3.4 Mounting

All traffic signal heads shall be mounted as shown on the design details or on the standard.

1.3.5 Aiming

Signal faces to be aimed to insure good visibility, and to the satisfaction of the ENGINEER. The following guidelines are to be followed:

- Rural Areas - aimed at 1000 feet
- Suburban Areas - aimed at 500 feet
- Urban Areas - aimed at 300 feet

In no instance is the signal face to be visible for a distance less than provided in the MUTCD table of Visibility Distance.

1.3.6 Signal Backplate

Signal Backplates shall be fastened using appropriate hardware recommended by the signal head manufacturer. The Backplate shall appropriately match signal head without cutting, bending, or breaking. Drilling holes to match screw patterns is acceptable. The backplate shall have a 2” retroreflective yellow border (Type XI (eleven) prismatic sheeting) applied, unless noted otherwise. See Standard Drawing for application.

1.3.7 Warranty Replacement

During the period of TWELVE (12) MONTHS following the date of ACCEPTANCE, the Manufacturer or Vendor shall replace, at no expense to the Department (including shipping costs), any part of Polycarbonate Vehicle Signal Head that fails by reason of defective material or workmanship, including peeling or chipping paint.

1.4 Measurement

The furnishing and/or installing of polycarbonate vehicle Signal Heads shall be measured by EACH type of head assembly with mounting hardware as specified on plans, including ALL internal electrical connections and ALL required incidental hardware.

The furnishing and/or installing of Signal Backplate shall be measured by EACH including ALL required mounting hardware.

1.5 Payment

Furnishing and Installing polycarbonate vehicle Signal Heads with 12 inch sections unless noted, measured as provided above, will be paid for at the contract unit price

For Signal Heads:

6865710	FURNISH & INSTALL 12" 1-WAY-5 SECTION(R.Y.YA.G.GA)VEHICLE TRAFFIC SIGNAL	EA
6887900	INSTALL 12" 1-WAY-5 SECTION(R.YA.GA.Y.G)VEHICLE TRAFF SIGNAL	EA
6865720	FURNISH & INSTALL 12" 1-WAY-4 SECTION(RA+RA/YA.GA)VEHICLE TRAFFIC SIGNAL	EA
6887901	INSTALL 12" 1-WAY-4 SECTION(RA+RA.YA.GA)VEHICLE TRAFF SIGNAL	EA
6865721	FURNISH & INSTALL 12" 1-WAY-4 SECTION(R.Y.G.GA)VEHICLE TRAFFIC SIGNAL	EA

6887902	INSTALL 12" 1-WAY-4 SECTION(R.Y.G.GA)VEHICLE TRAFFIC SIGNAL	EA
6865722	FURNISH & INSTALL 12" 1-WAY-4 SECTION(RA.YA.YAF.GA)VEHICLE TRAFFIC SIGNAL	EA
6887899	INSTALL 12" 1-WAY-4 SECTION(RA.YA.YAF.GA)VEHICLE TRAFFIC SIGNAL	EA
6865731	FURNISH & INSTALL 12" 1-WAY-3 SECTION(R.Y.G.)VEHICLE TRAFFIC SIGNAL	EA
6887904	INSTALL 12" 1-WAY-3 SECTION(R.Y.G.)VEHICLE TRAFFIC SIGNAL	EA
6865732	FURNISH & INSTALL 12" 1-WAY-3 SECTION(R.Y.GA.)VEHICLE TRAFFIC SIGNAL	EA
6887913	INSTALL 12" 1-WAY-3 SECTION(R.Y.GA.)VEHICLE TRAFFIC SIGNAL	EA
686573A	FURNISH & INSTALL 12" 1-WAY-3 SECTION(R.YA.GA.)VEHICLE TRAFFIC SIGNAL	EA
6887898	INSTALL 12" 1-WAY-3 SECTION(R.YA.GA.)VEHICLE TRAFFIC SIGNAL	EA
6865734	FURNISH & INSTALL 1 WAY -3 SECTION (R(12").Y(12").Y(8"))VEHICLE TRAFFIC SIGNAL	EA
6887912	INSTALL 1-WAY-3 SECT.(R(12").Y(12").Y(8"))VEH. TRAFF. SIGNAL	EA
6865735	FURNISH & INSTALL 12" 4-WAY-1 SECT.(R.Y.R.Y.)CLUST. MOUNT CAUTION HEAD	EA
6887911	INSTALL 12" 4-WAY-1 SECT.(R.Y.R.Y.)CLUST. MOUNT CAUTION HEAD	EA
6865736	FURNISH & INSTALL 12" 1-WAY-1 SECTION(RED)VEHICLE TRAFFIC SIGNAL	EA
6887908	INSTALL 12" 1-WAY-1 SECTION(RED)VEHICLE TRAFFIC SIGNAL	EA
6865737	FURNISH & INSTALL 12" 1-WAY-1 SECTION(YELLOW)VEHICLE TRAFFIC SIGNAL	EA
6887909	INSTALL 12" 1-WAY-1 SECTION(YELLOW)VEHICLE TRAFFIC SIGNAL	EA
6865738	FURNISH & INSTALL 12" 1-WAY-1 SECTION(GREEN)VEHICLE TRAFFIC SIGNAL	EA
6887910	INSTALL 12" 1-WAY-1 SECTION(GREEN)VEHICLE TRAFFIC SIGNAL	EA
6865748	FURNISH & INSTALL 12" 1-WAY-1 SECTION(RA)VEHICLE TRAFFIC SIGNAL	EA
6887905	INSTALL 12" 1-WAY-1 SECTION(RA)VEHICLE TRAFFIC SIGNAL	EA
6865749	FURNISH & INSTALL 12" 1-WAY-1 SECTION(YA)VEHICLE TRAFFIC SIGNAL	EA
6887906	INSTALL 12" 1-WAY-1 SECTION(YA)VEHICLE TRAFFIC SIGNAL	EA
6865739	FURNISH & INSTALL 12" 1-WAY-1 SECTION(GA)VEHICLE TRAFFIC SIGNAL	EA
6887907	INSTALL 12" 1-WAY-1 SECTION(GA)VEHICLE TRAFFIC SIGNAL	EA
6865740	FURNISH & INSTALL 8" 1-WAY-3 SECTION(R.Y.G.)VEHICLE TRAFFIC SIGNAL	EA
6887890	INSTALL 8" 1-WAY-3 SECTION(R.Y.G.)VEHICLE TRAFFIC SIGNAL	EA
6865746	FURNISH & INSTALL 8" 1-WAY-1 SECTION(RED)VEHICLE TRAFFIC SIGNAL	EA
6887891	INSTALL 8" 1-WAY-1 SECTION(RED)VEHICLE TRAFFIC SIGNAL	EA
6865747	FURNISH & INSTALL 8" 1-WAY-1 SECTION(YELLOW)VEHICLE TRAFFIC SIGNAL	EA
6887892	INSTALL 8" 1-WAY-1 SECTION(YELLOW)VEHICLE TRAFFIC SIGNAL	EA

For Signal Backplates:

6865834	FURNISH & INSTALL BACKPLATE W/ RETROREFL.BORDERS FOR TRAFFIC SIGNAL	EA
6887930	INSTALL BACKPLATE W/ RETROREFL.BORDER FOR TRAFFIC SIGNAL	EA

For LED Modules:

6886080	FURNISH & INSTALL 12" RED LED MODULE	EA
6886081	FURNISH & INSTALL 12" RED ARROW LED MODULE	EA
6886083	FURNISH & INSTALL 12" YELLOW LED MODULE	EA

6886084	FURNISH & INSTALL 12" YELLOW ARROW LED MODULE	EA
6886086	FURNISH & INSTALL 12" GREEN LED MODULE	EA
6886087	FURNISH & INSTALL 12" GREEN ARROW LED MODULE	EA
6887920	INSTALL LED MODULE (1-100 MODULES)	EA
6887921	INSTALL LED MODULE (101-500 MODULES)	EA
6887922	INSTALL LED MODULE (501-1000 MODULES)	EA

and such payment shall be full compensation for installing the specified equipment, materials, and incidentals to complete this item.

Pay Item Notes

This specification is not limited to these pay items. Other pay items may be applicable.

686.2 OPTICALLY PROGRAMMABLE VEHICLE SIGNAL HEAD

1.1 Description

This work shall consist of installing and/or furnishing a HIGH VISIBILITY, OPTICALLY PROGRAMMABLE, ADJUSTABLE FACE 12 INCH VEHICLE SIGNAL HEAD of the types, display, and at locations shown on the Plans, in accordance with these Specifications, and in close conformity with the lines shown on the Plans or established by the Engineer. Vehicle signal heads are stated separately from their mounting hardware. These signals are intended for use where the field of view must be limited, or where the features of high conspicuity is desirable. Hereinafter, Optically Programmable Signals shall be stated as OPS.

1.2 Materials

1.2.1 OPS Heads

All OPS heads shall be furnished by the SAME MANUFACTURER. Vehicle OPS Heads of the size, type, and arrangement specified, are to be furnished by the Contractor, together with ALL the necessary hardware for make-up and mounting. The basic material requirements are listed below.

The OPS shall permit the visibility zone of the signal indication to be determined optically; and shall require no hoods nor louvers to achieve that effect. The projected indication may be selectively visible (or veiled) anywhere within 15° of the optical axis. No indication shall result from external illumination (phantom), nor shall one light unit illuminate a second.

1.2.2 Optical System

The components of the optical system shall consist of:

1. Lamp
2. Diffuser Collar
3. Optical Limiter-Diffuser
4. Objective Lens

The LAMP shall be nominal 150 watt, 115 VAC, three prong, sealed beam PAR, having an integral reflector with stippled face, and having an average rated life of 6,000 hours when operated (with dimming) in an OPS according to manufacturer's specifications. Signal heads shall be furnished fully lamped. The Contractor must acquire sufficient spare lamps for operation until Final Acceptance.

The OPTICAL LIMITER shall provide an accessible imaging surface, which is at focus on the optical axis, for objects at 900 FEET to 1200 FEET distance, and permit an effective veiling mask to be variously applied as determined by the desired visibility zone. The optical limiter shall be provided with positive indexing means, and be composed of heat resistant glass.

The OBJECTIVE LENS shall be a high-resolution annular, incremental lens, which is hermetically sealed within a flat laminate of weather-resistant acrylic (or approved equal). The lens shall be symmetrical in outline, and may be rotated to any 90° orientation about the optical axis without displacing the primary image.

The OPTICAL SYSTEM shall accommodate projection of diverse, selected indications to separate portions of the roadway, such that only one indication will be simultaneously apparent to any viewer. The projected indication shall conform to ITE transmittance and chromaticity standards.

1.2.3 Housing Construction

The primary outer housing shall be die-cast ALUMINUM parts (NOT plastic), and shall conform to ITE alloy and tensile requirements. Painted parts shall have a chromate preparation prior to painting. The exterior of the signal case, lamp housing, and mounting flanges shall be finished with POWERED PAINT of FEDERAL YELLOW. The lens holder and interior of the case shall be optically flat black.

The signal case and lens holder shall be pre-drilled for backplates and visors. The hinge and latch pins shall be stainless steel. All access openings shall be sealed with weather-resistant rubber gaskets. Each section shall have two drain holes.

Sheet metal parts, including visors and backplates, shall conform to ITE material requirements, and shall include a chromate preparatory treatment, and be finished optically flat black on all surfaces unless otherwise specified.

1.2.4 Mounting

The signal shall mount to industry standard 1.5 INCH N. P. T. fittings as a single-section, as a multiple-section face, or in combination with other signals. The signal section shall be provided with an adjustable connection that permits incremental tilting from 0 to 10 degrees above or below the horizontal, while maintaining a common vertical axis, through couplers and mounting. Terminal connection shall permit external horizontal adjustment about the mounting axis, in 5 degree increments. The signal shall be installable with ordinary tools, and serviceable without tools.

Attachments such as visors, backplates or adapters shall conform, and readily fasten to existing mounting surfaces without affecting the sealing nor light integrity of the signal.

Contractor: note set-off requirements, that are particularly applicable to mast-arm mounting brackets.

1.2.5 Electrical

The Lamp Fixture shall consist of: a separately accessible housing with integral lamp support, an indexed ceramic socket, and a self aligning, quick-release lamp retainer. Electrical connection between case and lamp housing shall be accomplished with an interlock (plug) assembly which disconnects the lamp housing when opened. Each signal section shall include a covered terminal block for clip or screw attachment of field wires. The OPS shall be pre-wired, with concealed #18 AWG, stranded and coded wires, which shall interconnect all sections to permit field connection within any section.

1.2.6 Photo Controls

Each signal shall include integral means (dimmer/intensity controller) for regulating the intensity of light output, (between limits) as a function of individual background ambient illumination. Lamp intensity shall not be less than 97% of the uncontrolled intensity at 1000 ft.-candle; and shall reduce to 15% (\pm 2%) of maximum intensity at light levels less than 1 ft.-candle, (over the applied voltage and ambient temperature range). Response shall be proportional, and be essentially instantaneous to any detectable increase from darkness up to 1000 ft.-candle; and be damped for any decrease below 1000 ft.-candle.

The intensity controller shall be comprised of an integrated, directional light sensing and regulating device, inserted between lamp and field wires.

The device shall be responsive over an applied voltage of 95 to 130 VAC, 60 Hz.; and a temperature range of -40 to 74°C (-40 to +165°F); and may provide phase controlled output voltage, but shall have a nominal open circuit terminal impedance of 1000 ohms.

1.2.7 Mounting Assemblies

All mounting hardware shall be furnished for either Span-Wire, Mast-Arm, Side-Pole, or Post-Top mounting as required by the Plans. Hardware for Span-Wire, Side-Pole, and Post-Top mounting shall be finished Federal YELLOW. The adjustable brackets for Mast-Arm mounting shall have a finish of NATURAL stainless steel or aluminum.

For Span-Wire mounting, the hanger shall be CAST ALUMINUM, and shall contain two stainless steel (2) J-Hooks, and have six (6) notches to position the hanging signal. The weatherhead entrance BUSHING shall have a 1.5 INCH hole for wire entry. All span-wire mounted OPS shall have a fitting for attaching the Bottom-Tether cable, which shall be installed by the Contractor. For span-wire mounted OPS, the manufacturer shall provide, and the Contractor install, a 42 INCH BOTTOM STABILIZER BAR, which shall have a finish of NATURAL stainless steel or aluminum.

For 5-SECTION CLUSTER signal assemblies, ONE mounting bracket top-fitting shall be furnished, attached to the single top red section. Then a pipe T-section will connect to both two-section sides, forming a 5-section "school-house" shaped cluster. (See Design Detail drawing.) A 2 INCH wide ribbed, cast aluminum BOTTOM BRACKET (No. 10 018 or equiv.), having holes 17 INCHES on-center, shall be used to unify the assembly. (The two sides of the cluster shall be not more than 8 INCHES apart; and the bottoms shall be level.)

For 4-SECTION "T" ASSEMBLY, ONE mounting bracket top-fitting shall be furnished, together with two (2) cast aluminum brackets. (See Design Detail Drawings.) The two red sections shall be not more than 8 INCHES apart.

Backplate

Where specified, a BACKPLATE conforming to the size and shape of the required signal configuration, shall be provided by the same Manufacturer. Back plates shall be ALUMINUM, and shall be colored dull black front and back. The color shall be anodized.

All Span-Wire mounted signals having a Backplate, shall have a bottom TETHER.

1.2.8 Packaging

Each single span-wire mounted traffic signal, complete with hangers and visors, completely assembled, shall be packaged in a separate corrugated cardboard box. It shall be clearly labeled on the END of the box, in plain English, as to the type of signal contained therein. For other types of Signal Heads, again, the signal shall be complete in its own box, with a separate plainly labeled box containing the brackets, trunions, and miscellaneous hardware. (For example labeled: "Side-arm hardware for 12 INCH pedestrian signal".)

Four- and Five-section cluster signals shall likewise be singly boxed, completely assembled, with visors and span-wire mounting hardware. Because of the weight, five-section clusters shall be packed 2 or 3 per standard pallet.

Backplates may be packaged separately and shall be protected from shipping damage to the paint.

1.2.9 Certification

CATALOG CUTS ARE REQUIRED

The Contractor shall provide a written Certification from the Manufacturer that ITE STANDARDS have been met (for heads & lamps.)

The Contractor shall provide design details and drawings in sufficient detail for complete evaluation of the Proposal, and comparison with these Specifications. Any exceptions to these Specifications must be stated in writing.

Upon request of the Engineer, the Contractor shall submit for approval, one (1) sample of EACH required Signal Head type specified. For example, one 12-INCH 3-section vehicle head; etc., if specified. The hardware system for producing a 5-section cluster shall be completely illustrated, but sample is not required.

1.2.10 Warranty

The Contractor shall furnish the Engineer with any warranties on equipment, materials and lamps, that are provided by the Manufacturer or Vendor as normal trade practice.

1.3 Construction

1.3.1 Location and Aiming

OPS Heads shall be installed where shown on the Plans, and shall be positioned according to the Design Details or the Standards, or at other locations as directed by the ENGINEER.

Following "turn-on" of the new controller and new OPS, the ENGINEER shall field inspect the visibility zone, and shall instruct the Contractor to revise the masking if necessary.

1.3.2 Installation

1.3.2.1 Mounting

The OPS shall be mounted and aimed before masking. For span wire mounting, the top cable shall have 3% sag, and a taught bottom tether shall be installed, together with the stabilizer bar. There shall be no sway or movement in a 15 MPH wind.

1.3.2.2 Aiming

The OPS shall be installed, aimed and masked as recommended in the Manufacturer's "Installation Instructions and Design, Installation and Maintenance Guide". It is the responsibility of the Contractor to be thoroughly familiar with this manual, and with the techniques of masking. Each section of the signal shall be masked with special heat-proof OPS Masking Tape in an acceptable and professional manner.

1.3.3 Mounting Details

The top section of all vehicle Signal Heads mounted on the same pole or pedestal shall be within (6 inches) of all being the same height, unless otherwise specified on the Plans.

All multi-section/combination Signal Heads shall be arranged with their TOP sections at the same elevation as other Signal Heads (rather than the bottom of the head).

1.3.4 Clearance

Signal heads placed over the roadway shall be installed to provide a ROAD CLEARANCE of 17 to 19 feet. This clearance shall be measured from the pavement to the lowest part of the assembly.

Signal heads mounted on poles or pedestals shall be mounted to provide a nominal clearance of 10 feet; ranging from 8 to 15 feet above the surface grade.

1.3.5 Wiring

Electrical cable shall be connected to the terminals in each Signal Head to provide the proper display indication when the other end is connected to the controller cabinet field terminals.

External splicing of cable shall NOT be permitted. Electrical cable runs shall be as indicated in these Specifications, and as shown on the Plans.

1.3.6 Hardware

All hardware is to be non-corrosive material, or chemically compatible with the item being used. All Signal Heads which are to be rigidly mounted, shall be done so by the use of adjustable signal brackets. All brackets and suspensions shall be painted Federal YELLOW or as directed by the ENGINEER (except mast arm mounts which shall be natural.)

1.4 Measurement

Furnishing and/or Installing of Optically Programmable Signal Heads shall be measured by EACH type of head assembly specified, and mounting method specified. Included, shall be, Mounting Assemblies, bottom tether bracket, stabilizer bar and ALL electrical connections and all required incidental hardware.

1.5 Payment

Furnishing and/or Installing OPS vehicle Signal Heads, measured as provided above, will be paid for at the contract unit price for:

6865750	FURNISH & INSTALL 12" OPTICALLY PROG.1-WAY-5 SECT.VEH.TRAF.SIGNAL (R.Y.YA.G.GA)	EA
6887915	INSTALL OPTICALLY PROG.1-WAY-5SECT.VEH.TRAF.SIG (R.Y.YA.G.GA)	EA
6865760	FURNISH & INSTALL 12" OPTICALLY PROG.1-WAY-4 SECT.VEH.TRAF.SIGNAL (R+R.YA.GA)	EA
6887916	INSTALL OPTICALLY PROG.1-WAY-4SECT.VEH.TRAF.SIG (RA+RA.YA.GA)	EA
6865761	FURNISH & INSTALL 12" OPTICALLY PROG.1-WAY-4 SECT.VEH.TRAF.SIGNAL (R.Y.G.GA)	EA
6887917	INSTALL OPTICALLY PROG.1-WAY-4SECT.VEH.TRAF.SIG (R.Y.G.GA.)	EA
6865770	FURNISH & INSTALL 12" OPTICALLY PROG.1-WAY-3 SECT.VEH.TRAF.SIGNAL (R.Y.G.)	EA
6887919	INSTALL OPTICALLY PROG.1-WAY-3SECT.VEH.TRAF.SIG (R.Y.G.)	EA
6865771	FURNISH & INSTALL 12" OPTICALLY PROG.1-WAY-3 SECT.VEH.TRAF.SIGNAL (R.Y.GA.)	EA
6887918	INSTALL OPTICALLY PROG.1-WAY-3SECT.VEH.TRAF.SIG (RA.YA.GA.)	EA
6888310	INSTALL OPTICALLY PROGRAMMED VEHICLE TRAFFIC SIGNAL	EA

and such payment shall be full compensation for furnishing and installing the specified equipment, Signal Head aiming, MASKING, electrical connections, and for all necessary hardware and incidentals.

Pay Item Notes

This specification is not limited to these pay items. Other pay items may be applicable.

686.3 PEDESTRIAN SIGNAL HEAD

1.1 Description

This work shall consist of installing and/or furnishing a LED (Light Emitting Diode) PEDESTRIAN SIGNAL HEAD, with SUN VISOR and designated mounting hardware and a LED (Light Emitting Diode) COUNTDOWN PEDESTRIAN SIGNAL HEAD, with SUN VISOR and designated mounting hardware, in accordance with these Specifications.

The pedestrian head and the mounting hardware are stated as one item.

1.2 Materials

Acceptable materials can be found on the current SCDOT Qualified Products List. Product Specifications for acceptable materials are located at http://www.scdot.org/doing/publications_Traffic.aspx

1.1 Construction

1.1.1 Location

Pedestrian signal heads shall be installed where shown on the Plans or at other locations as directed or permitted by the RCE.

Pedestrian signal heads mounted on the same pole or pedestal, shall be within 6 INCHES of being the same height unless otherwise specified on the Plans.

1.1.2 Clearance

Pedestrian signal heads shall be mounted so that no portion of the assembly is closer than 18 INCHES to the face of the curb.

Pedestrian signal heads mounted on poles or pedestals shall be mounted to provide a clearance of 9 to 10 feet from the surface grade.

1.1.3 Wiring

Electrical cable shall be connected to the terminals in each signal head to provide the proper display indication when energized by the signal controller.

External splicing of cables shall not be permitted.

Electrical cable runs shall be as indicated in Design Details, the Wiring Diagram, or as shown on the Plans.

1.1.4 Hardware

All hardware is to be non-corrosive material.

All brackets, arms, and other hardware shall be painted FEDERAL YELLOW, or as directed by the ENGINEER.

1.1.5 Mounting

All pedestrian signal heads shall be mounted as shown on the Design Details, the Standard Drawings, or the Signal Plans.

See Standard Drawings for mounting information on Clamshell Mount, Side of Pole Mount, Single Post Top Mount, and Dual Post Top Mount.

1.1.6 Warranty

The Contractor shall furnish the ENGINEER with any warranties on materials that are provided by the Manufacturer or Vendor as normal trade practice.

1.2 Measurement

The furnishing of pedestrian signal heads shall be measured by EACH type of head assembly and/or mounting method specified with LED module installed, including ALL internal electrical connections and all incidental hardware.

1.3 Payment

Furnishing and/or installing pedestrian signal heads with LED modules and clamshell mounts, measured as provided above, will be paid at the contract unit price bid for:

6865782	FURNISH & INSTALL 1-WAY-1SECT. PEDESTRIAN SIGNAL HEAD W/ HAND/MAN LED MODULE AND CLAMSHELL MOUNT FOR SIDE POLE (LEFT)	EA
6865783	FURNISH & INSTALL 1-WAY-1SECT. PEDESTRIAN SIGNAL HEAD W/ HAND/MAN LED MODULE AND CLAMSHELL MOUNT FOR SIDE POLE (RIGHT)	EA
6865784	FURNISH & INSTALL 1-WAY-1SECT. PEDESTRIAN SIGNAL HEAD W/ HAND/MAN COUNTDOWN LED MODULE AND CLAMSHELL MOUNT FOR SIDE POLE (LEFT)	EA
6865785	FURNISH & INSTALL 1-WAY-1SECT. PEDESTRIAN SIGNAL HEAD W/ HAND/MAN COUNTDOWN LED MODULE AND CLAMSHELL MOUNT FOR SIDE POLE (RIGHT)	EA
6888320	INSTALL PEDESTRIAN SIGNAL HEAD	EA

Furnishing and/or installing pedestrian signal heads with LED modules (no mounting hardware included), measured as provided above, will be paid at the contract unit price bid for:

6865780	FURNISH & INSTALL 1-WAY-1SECT. PEDESTRIAN SIGNAL HEAD W/ HAND/MAN LED MODULE	EA
6865781	FURNISH & INSTALL 1-WAY-1SECT. PEDESTRIAN SIGNAL HEAD W/ HAND/MAN COUNTDOWN LED MODULE	EA

Furnishing and/or installing mounting hardware, measured as provided above, will be paid at the contract unit price bid for:

6865840	FURNISH & INSTALL PEDESTRIAN TRAF. SIGNAL HEAD MOUNTING ASSEMBLY FOR POST TOP	EA
6865841	FURNISH & INSTALL PEDESTRIAN TRAF. SIGNAL HEAD MOUNTING ASSEMBLY FOR SIDE POLE	EA
6865842	FURNISH & INSTALL PED. TRAF. SIGNAL HEAD MOUNT. ASSEMBLY FOR DUAL POST TOP	EA

Furnishing and/or installing hand/man LED module or hand/man countdown LED module, measured by EACH, shall be complete with weather tight neoprene gasket for retrofitting existing pedestrian signal heads if applicable and shall be paid at the contract unit price bid for:

6865788	FURNISH & INSTALL HAND/MAN LED MODULE	EA
6865789	FURNISH & INSTALL HAND/MAN COUNTDOWN LED MODULE	EA
6887925	INSTALL PEDESTRIAN LED MODULE	EA

Furnishing and/or installing visor with attachment screws (corrosion resistant) for retrofitting existing pedestrian signal heads for LED module use, measured by EACH, shall be paid at the contract unit price bid for:

6865787	FURNISH & INSTALL VISOR WITH ATTACHMENT SCREWS	EA
6887926	INSTALL VISOR WITH ATTACHMENT SCREWS	EA

and such payment shall be full compensation for furnishing the specified equipment and for all necessary hardware and incidentals to complete this item.

Pay Item Notes

This specification is not limited to these pay items. Other pay items may be applicable.

686.4 PEDESTRIAN PUSH BUTTON STATION ASSEMBLY WITH SIGN

1.1 Description

This work shall consist of installing and/or furnishing a AMERICAN DISABILITIES ACT APPROVED ALUMINUM PEDESTRIAN PUSH BUTTON STATION ASSEMBLY AND PUSH BUTTON SIGN, of the types, sizes, and mountings specified in accordance with these Specifications or and at locations shown on the Plans or as established by the ENGINEER.

1.2 Materials

Acceptable materials can be found on the current SCDOT Qualified Products List. Product Specifications for acceptable materials are located at http://www.scdot.org/doing/publications_Traffic.aspx

1.3 Construction

1.3.1 Push Button Station Assembly

Push button station assemblies shall be installed where shown on the Plans, or as directed by the ENGINEER.

Push button station assemblies placed on poles shall be at a height of 3-1/2 to 4 feet ABOVE GRADE.

The push button and sign shall be oriented and wired in such a manner to clearly indicate to the pedestrian, the crosswalk with which it is associated.

Push button station assemblies shall be attached to poles using 1 inch stainless steel bands or galvanized screwed directly to pole. If dual push button station assemblies are mounted, a dual standoff mounting bracket shall be used to mount them with proper orientation. The finished assembly shall be very firmly secured.

On metal poles, the cable for the push buttons shall be brought through the rear of the assembly directly into the pole or controller cabinet. On wooden poles electrical conduit shall be used.

Each push button station assembly shall be connected with the appropriate electrical cable, and wired to actuate the proper phase of the controller. The necessary cable is specified as a separate item. (See 677.1 ELECTRICAL CABLE). The cable shall not be spliced.

1.3.2 Push Button Signs

Each push button sign shall be installed on the station assembly and reflect the proper intention of the pedestrian movement.

1.3.3 Warranty

The Contractor shall furnish the ENGINEER with any warranties on materials that are provided by the Manufacturer or Vendor as normal trade practice.

1.4 Measurement

Furnishing and installing pedestrian push buttons and signs shall be measured by each unit, in place, including all incidental hardware, including dual mounting brackets, and making electrical connections.

1.5 Payment

Furnishing and/or installing pedestrian push button station assembly and sign, measured as provided above, will be paid for at the contract unit price bid for:

6865793	FURNISH & INSTALL PEDESTRIAN PUSH BUTTON MICROSWITCH TYPE STATION ASSEMBLY (9"x12") AND SIGN (R-10-3E)	EA
6865794	FURNISH & INSTALL PEDESTRIAN PUSH BUTTON MICROSWITCH TYPE STATION ASSEMBLY (9"x15") AND SIGN (R-10-3E)	EA
6865795	FURNISH & INSTALL PEDESTRIAN PUSH BUTTON MICROSWITCH TYPE	EA
6865796	FURNISH & INSTALL PEDESTRIAN PUSH BUTTON SOLID STATE WITH LIGHT AND TONE STATION ASSEMBLY (9"x12") AND SIGN (R-10-3E)	EA
6865797	FURNISH & INSTALL PEDESTRIAN PUSH BUTTON SOLID STATE WITH LIGHT AND TONE STATION ASSEMBLY (9"x15") AND SIGN (R-10-3E)	EA
6865798	FURNISH & INSTALL PEDESTRIAN PUSH BUTTON SOLID STATE WITH LIGHT AND TONE	EA
6888325	INSTALL PEDESTRIAN PUSH BUTTON STATION ASSEMBLY AND SIGN	EA

which shall be full compensation for installing/furnishing and installing all materials including all labor and incidentals necessary to complete the work as specified.

Pay Item Notes

This specification is not limited to these pay items. Other pay items may be applicable.

686.5 SYMBOLIC LED BLANKOUT SIGN

1.1 Description

This work shall consist of installing and/or furnishing a Symbolic LED (Light Emitting Diode) No Right/Left Turn Blankout Sign, of Clam-Shell configuration, with Sun Visor and designated mounting hardware. The Blankout Sign and the mounting hardware are stated as one item.

1.2 Materials

Acceptable materials can be found on the current SCDOT Qualified Products List. Product Specifications for acceptable materials are located at http://www.scdot.org/doing/publications_Traffic.aspx

1.1 Construction

1.1.1 Location

The Blankout Message Signal Heads shall be installed where shown on the Plans, positioned according to the Design Details or the Standards, or at other locations as directed by the Engineer.

1.1.2 Wiring

Electrical cable shall be splice-free lengths of:

NO. 14 COPPER WIRE, 4 CONDUCTOR, BLACK

or as directed by the Engineer.

External splicing of cable shall NOT be permitted. Electrical cable runs shall be as indicated in these Specifications, and as shown on the Plans.

1.1.3 Hardware

All hardware is to be non-corrosive material, or chemically compatible with the item being used.

All Blankout Signal Heads which are to be rigid mounted shall be done so by the use of adjustable signal brackets.

All brackets and suspensions shall be painted Federal YELLOW or as directed by the Engineer (Except mast arm mounts).

1.1.4 Mounting

All Blankout Signal Heads shall be mounted as shown on the Design Details or on the Standards.

1.1.5 Signal Aiming

Signal faces are to be hung and aimed to insure good visibility, to the satisfaction of the Engineer. Blank out signs should generally be aimed to have the brightest image result, at about 30 feet beyond the stop line.

1.1.6 Warranty

The Contractor shall furnish the ENGINEER with any warranties on materials that are provided by the Manufacturer or Vendor as normal trade practice.

1.2 Measurement

The furnishing and/or installing of No Right/Left Turn Symbolic LED Blankout Sign shall be measured by EACH with LED module installed, including ALL internal electrical and electronic hardware, structural materials, housings, and all the necessary hardware for proper mounting.

Furnishing and/or installing No Right/Left Turn Symbolic LED Module, measured by each, shall be complete with weather tight neoprene gasket for replacing defective existing modules if applicable.

1.3 Payment

Furnishing and/or Install Blankout Sign with LED module with span wire mount, measured as provided above, will be paid at the contract unit price bid for:

6865820	FURNISH & INSTALL NO RIGHT/LEFT TURN SYMBOLIC LED BLANKOUT SIGN W/ SPAN WIRE MOUNTING	EA
6887928	INSTALL NO RIGHT/LEFT TURN SYMBOLIC LED BLANKOUT SIGN W/ SPAN WIRE MOUNTING	EA

Furnishing and/or Install Symbolic LED module, measured as provided above, will be paid at the contract unit price bid for:

6865821	FURNISH & INSTALL NO RIGHT/LEFT TURN SYMBOLIC LED MODULE	EA
6887927	INSTALL NO RIGHT/LEFT TURN SYMBOLIC LED MODULE	EA

and such payment shall be full compensation for furnishing the specified equipment and for all necessary hardware and incidentals.

Pay Item Notes

This specification is not limited to these pay items. Other pay items may be applicable.

688.1 REMOVAL SALVAGE AND DISPOSAL OF EQUIPMENT AND MATERIALS

1.1 Description

This work consists of the Removal and Salvage, or the Removal and Disposal of equipment and materials, during the construction of this project. Construction includes new installations, and the modification, or removal of existing traffic signals. When the Project is within the city limits, the local SCDOT District Shop shall be given the first right of refusal. If the equipment is declined, it shall next be offered to the City. If also declined, it shall be disposed of, as stated below.

1.2 Materials

1.2.1 *Controllers and Cabinets*

Prior to removal, every cabinet, controller, conflict monitor, detector amplifier, and other major equipment item shall be clearly tagged with the intersection name from which it is being removed. Cabinet, controller, and conflict monitor serial numbers shall be recorded and transmitted to the SCDOT Signal Shop supervisor. Then, each piece of equipment shall be carefully removed from the cabinet and boxed. The pins and threaded portions of the connectors, shall be protected with plastic covers, or the harnesses left in place to prevent damage. The cabinet with all other related equipment (clocks, flashers, load switches, etc.) may then be removed and transported intact. The foundations of ground mounted cabinets shall be removed completely, or cleared to a minimum depth of 18 inches below surface grade.

1.2.2 *Signal Heads*

Vehicle and pedestrian traffic signal heads to be removed and salvaged shall be carefully dismantled, keeping as much of the hardware intact as possible. During the removal and delivery, special care should be taken to prevent damage to the lenses and visors.

1.2.3 *Metal Poles*

This includes the removal and salvage of strain poles, pedestal poles, and their related hardware (pole caps, bolt covers, hand hole covers, nuts, transformer bases, etc.). The pole foundations shall be removed completely, or cleared to a minimum depth of 18 inches below surface grade.

Where shown on the Plans, some pole or cabinet foundations may be designated for complete removal (road widening, etc.). In these cases the concrete base shall be loosened, pulled out of the hole, and disposed.

1.2.4 *Wood Poles*

Wood Poles that are not utilized in the new signalization, and are not required by other utilities, shall be removed. The ENGINEER shall make the determination whether each wooden pole shall be salvaged or disposed. Back guys, grounding systems, and miscellaneous hardware shall be disposed.

1.2.5 *Miscellaneous Equipment*

Minor equipment shall be removed from the site and discarded. This includes steel cable, electrical cable, conduit, pedestrian buttons and signs, concrete pads, and

spliceboxes/pullboxes/handboxes not utilized in the new signalization. Underground conduit and detector loops not utilized, shall be abandoned in place.

1.2.6 Signs

Highway signs on existing span wires shall be removed and salvaged immediately after the replacement signs have been installed.

1.3 Construction

1.3.1 Removal and Salvage

These items are to be carefully removed from the job site, salvaged, and returned to the Department. The items of major equipment to be salvaged are listed on the Plans. The Contractor shall deliver, and obtain a RECEIPT for, the salvaged equipment, to:

SCDOT DISTRICT SIGNAL SHOPS

District 1: 1408 Shop Road, Columbia, SC 29201
(803) 737-6973
District 2: 510 W. Alexander Ave., Greenwood, SC 29646
(864) 227-8651
District 3: 13 Saluda Dam Road, Greenville, SC 29611
(864) 241-1117
District 4: 300 Armory Road, Chester, SC 29706
(803) 581-8551
District 5: RT 76/301 E. Palmetto Street, Florence, SC 29503
(843) 661-4812
District 6: 6355 Fain Blvd., North Charleston, SC 29418
(843) 740-1668
District 7: 1768 Charleston Hwy, Orangeburg, SC 29116
(803) 531-6870

1.3.2 Disposal

Material NOT to be salvaged shall be removed from the job site, become the property of the Contractor; and should be properly disposed by the Contractor, at an APPROVED LAND FILL (or material reclamation yard). Any materials designated as HAZARDOUS WASTE shall be disposed in accordance with regulations enforced by the SC Department of Health and Environmental Control (DHEC), Bureau of Solid and HAZARDOUS Waste; (803)-734-5000 for information.

1.3.3 Inspection

Removal and disposal quantities will not be measured as pay items, but shall be included in the price bid for Removal, Salvage, and Disposal. FINAL ACCEPTANCE and Final Payment will be withheld, if the Contractor has not removed unneeded equipment from the job site, and if the Contractor cannot present RECEIPTS from the Shop showing that the salvaged equipment has been delivered to the Department as specified.

1.3.4 Holes

Every hole caused by removing old equipment shall be filled THE SAME DAY. It shall be back-filled, compacted, and reseeded/sodded, to the satisfaction of the ENGINEER. Holes in PAVEMENT shall be cleanly side-trimmed, then brought to grade and finished with the same paving material as the

adjacent pavement. Sidewalk "squares" shall be completely replaced (complete square), using forms and expansion material.

1.4 Measurement

The Removal, Salvage, and Disposal of traffic signal materials and related equipment, will not be measured, but shall be paid as a Lump Sum or Each item as described in special provisions and covering all intersections named in the Contract. The related costs of transportation, disposal, concrete, pavement repair, etc., will not be measured for payment, but shall be included in the bid price of Removal, Salvage, and Disposal.

1.5 Payment

The Removal, Salvage, and Disposal of equipment and materials, shall be paid at the Contract price bid for

6885990	REMOVAL,SALVAGE,&DISP.OF EXISTING TRAF. SIGNAL EQUIPMENT	LS
6885991	REMOVAL,SALVAGE,&DISP.OF EXISTING TRAF. SIGNAL EQUIPMENT	EA

Remove Foundation for Steel Strain Pole – 18 inches below grade shall be paid at the Contract price bid for

6885982	REMOVE FOUNDATION OF STEEL STRAIN POLE - 18" BELOW GRADE	LS
6887941	REMOVE FOUNDATION OF STEEL STRAIN POLE - 18" BELOW GRADE	EA

which shall be full compensation for the removal, salvage, and disposal, with transportation, and for all labor, equipment, materials and incidentals to perform the work as specified.

Pay Item Notes

This specification is not limited to these pay items. Other pay items may be applicable.

688.2 TEMPORARY ADJUSTMENT OF TRAFFIC SIGNAL EQUIPMENT AND TIMINGS

1.1 Description

1.1.1 General

This work consists of the Temporary Adjustment of traffic control signal equipment and materials, during the construction of this project. Highway construction often features new road alignment, a new cross section (widening), and a change in grade. Sometimes the maintenance of traffic requires the relocation of an intersection, or the installation of a temporary "construction" traffic signal. Relocation of signal equipment may also be required to avoid interference with heavy equipment. This item has been established to cover the equipment, materials, and labor that may be required to temporarily adjust the physical location of traffic signal features, such as poles, controller, steel cable, electrical cable, signal heads, etc. This item is also used to cover the installation and removal of a TEMPORARY CONSTRUCTION SIGNAL.

The intersections or locations for Temporary Adjustment are shown on the Plans, or stated in a "List of Intersections". After all Temporary Adjustments have been made, and after the road construction has been completed, the final result shall be the traffic signals shown in the Plans.

The amount of work required by this item will vary greatly between projects. The Bidder/Contractor should carefully study the Road Plans, the staging of work, and the Signal Plans, to estimate the work required.

1.1.1.1 Companion Specifications

See Special Provisions for Maintenance of Operation.
See 688.1 REMOVAL, SALVAGE, AND DISPOSAL.

1.1.1.2 Continuity of Signal Operation

The Maintenance of Traffic (as provided in the Traffic Control Plan), and the SAFETY OF TRAFFIC is of prime importance. Safety will be enhanced by providing for the continuous operation of traffic signals. Signals shall NOT be arbitrarily turned off for the convenience of the CONTRACTOR. Instead, the adjusted, temporary signal shall be constructed, and the operation smoothly transferred to that signal. When the ENGINEER gives permission to briefly turn off a signal, complete intersection control using a flagger and/or Police traffic direction shall be provided.

Fixed time operation of signals is typically not acceptable. CONTRACTOR shall provide temporary activation devices such as video detection for long term projects. These video detection cameras shall be installed and/or furnished as a separate pay item in accordance with 688.3 Video Detection – Loop Emulation System. The ENGINEER will determine if "fixed time" operation of actuated signals is permissible when the old loop detectors are abandoned. Unless noted otherwise on the Plans, or stated in the Special Provisions, the CONTRACTOR shall provide SPECIAL DETECTION SYSTEMS to provide semi- or full-actuation of a Controller. If required, Special Detection may include Microwave, Infrared, sonic, or video camera detection. The equipment shall be NEW, and shall be installed and aimed per the manufacturer's specifications. Unless noted otherwise, it is not permissible to adopt "uncoordinated" operation of adjacent signals; and when the old interconnection cable has been broken, it shall be repaired immediately. If possible, the District Traffic ENGINEER should be requested to provide temporary controller time settings for these conditions.

These temporary time settings may occur throughout the project life and therefore the contract will be paid for each site visit as necessary by bid item: **TEMPORARY TIMING ADJUSTMENT PER SITE VISIT**; and this work shall include all intersections needing timing adjustments per site visit. Site shall be defined as project limits.

Unless noted otherwise, the ENGINEER or stated on the Plans, full Continuity of Operation shall be provided; and shall include the installation of a temporary Controller at the adjusted location, and transferring operation to it, simultaneously turning off the old controller.

The appearance of temporary signals shall be fully professional. Signal heads shall be placed at the proper HEIGHT above the road, and at the correct ALIGNMENT with lanes of traffic, and at the proper DISTANCE from the stop line (see SCDOT Standard Drawings).

Temporary equipment shall be fully reliable, fully functional, and of good appearance.

1.1.1.3 Coordination of Work

The CONTRACTOR is advised to completely coordinate work between sub-contractors, and to carefully stage the project to minimize the work required by this item.

1.1.1.4 Final Configuration

Signal equipment that has been relocated or adjusted shall be considered as "temporary". The CONTRACTOR shall plan and stage the work so that the end result is a traffic signal installation conforming to the plans and using all NEW equipment.

1.1.2 ***Operation, Maintenance and Emergency Service (as indicated in Special Provisions)***

There is no separate pay item for Operation, Maintenance and Emergency Service. However, it is required as part of the contract for signal construction.

1.1.3 ***Specific Items***

1.1.3.1 Possession

All TEMPORARY signal heads, signs, and poles shall revert to the CONTRACTOR at the end of the Project. All temporary NEW Controllers and Cabinets, and NEW Special Detectors shall revert to the Department or to the Jurisdiction at the end of the project.

1.1.3.2 Signal Heads

Signal heads not in use shall be covered with a burlap bag. Signal heads shall be shifted side-to-side to be over traffic lanes as they are opened or closed to traffic.

1.1.3.3 Poles

The location of temporary and final signal poles shall be approved by the ENGINEER.

1.1.3.4 Joint Use Poles

Poles used for traffic signals, are often owned and used by other overhead cable utility companies. Full coordination and cooperation with those utilities shall be maintained when staging the signal work. The CONTRACTOR shall furnish the temporary and final wood poles as necessary for Continuity of Operation. Back Guys shall be provided for wood poles, sufficient to keep the pole vertical.

1.1.3.5 Detector Loops

Final Detector Loops shall only be installed after completion of all work activities which might damage the loops. Detector Loops may more conveniently be installed in the base paving course, and covered with the final surface. It is preferred that loops be paved over rather than installed in saw cuts upon completion of paving.

1.1.3.6 Miscellaneous Equipment

Minor equipment may be RE-USED in temporary adjusted configurations, but not in the final configuration. This includes steel cable, electrical cable, conduit, pedestrian buttons and signs, and spliceboxes/pullboxes/handboxes not utilized in the new signalization. The CONTRACTOR shall furnish sufficient steel cable and electrical cable to provide Continuity of Operation.

1.1.3.7 Signs

Highway signs on existing steel cable (span wires), shall be transferred to the adjusted spans, and placed in the same physical alignment. The Contract will usually specify new signs for the final configuration. (Ground mounted signs are covered in Section 107.11 of the STANDARD SPECIFICATIONS.)

1.1.3.8 Electric Service

The CONTRACTOR shall install temporary electric service(s) as necessary to operate the signal(s). Coordination with the local power company and with the ENGINEER is the responsibility of the CONTRACTOR, as are all permits or licenses.

1.1.3.9 Telephone Service

The CONTRACTOR shall install telephone service(s) as necessary to operate the signal(s). Coordination with the local telephone company and with the ENGINEER is the responsibility of the CONTRACTOR, as are all permits or licenses.

1.2 Measurement

The Temporary Adjustment of traffic signals may be measured as EACH or LUMP SUM based on the contract. Lump Sum is typically used with Design, Bid, Build or Design Build contracts. Each is typically used for Work Order contracts.

Either way, the CONTRACTOR shall provide all signal materials and related equipment, and shall adjust these features as often as necessary during the course of the project, coordinating with other construction.

To prepare their cost estimate, the CONTRACTOR should develop an assessment of the work required over the life of the Contract, for EACH INTERSECTION shown on the "List of Intersections", or listed as a Temporary Construction Signal. The LUMP SUM is the total of these prices.

1.3 Payment

Temporary Timing Adjustment of traffic signals shall be paid at the line item Contract price:

6885996	TEMPORARY TIMING ADJUSTMENTS PER SITE VISIT	EA
---------	---	----

Temporary Adjustment of traffic signals shall be paid at the line item Contract price:

6885992	TEMPORARY ADJUSTMENT OF TRAFFIC SIGNAL EQUIPMENT	LS
6885993	TEMPORARY ADJUSTMENT OF TRAFFIC SIGNAL EQUIPMENT	EA

Install Telephone Service for traffic signals shall be paid at the line item Contract price:

6887933	INSTALL TELEPHONE SERVICE FOR TRAFFIC SIGNAL	EA
---------	--	----

Payment for Temporary Adjustment (LS) shall be made according to the same Schedule as shown in the Specification "Traffic Control Plan", namely:

% Contract Complete:	1-5%	6-15%	16-29%	30-49%	50-69%	70-89%	90-100%
% Payment for T.A.:	20%	40%	60%	70%	80%	90%	100%

The payment for adjusting traffic signal equipment shall be full compensation for furnishing all materials, labor, equipment, tools, and incidentals to perform the work as specified.

Pay Item Notes

This specification is not limited to these pay items. Other pay items may be applicable.

688.3 VIDEO DETECTION - LOOP EMULATION SYSTEM

1.1 Description

This work consists of designing, furnishing, installing and providing on-site training during installation for video imaging loop emulation detection systems with all necessary hardware and software in accordance with the plans and specifications.

1.2 Materials

Acceptable materials can be found on the current SCDOT Qualified Products List. Product Specifications for acceptable materials are located at http://www.scdot.org/doing/publications_Traffic.aspx

1.3 Construction

Arrange and conduct site surveys with SCDOT personnel to determine proper camera sensor unit selection and placement. Provide SCDOT at least 3 working days notice before conducting site surveys. Upon completion of the site surveys, provide SCDOT with revised plans reflecting the findings of the site survey.

As determined during the site survey, install sensor junction boxes with nominal 6 x 10 x 6 inches dimensions at each sensor location. Provide terminal blocks and tie points for power cable

Place into operation loop emulator detection systems. Configure loop emulator detection systems to achieve required detection in designated zones. Have a certified manufacturer's representative on site to supervise and assist with installation, set up, and testing of the system.

Perform modifications to camera sensor unit for gain, sensitivity, and iris limits necessary to complete the installation.

Do not install camera sensor units on signal poles unless approved by the ENGINEER

Install a power cable appropriately sized to meet the power requirements of the sensors. At a minimum, provide three conductor 120 VAC field power cable.

Install the necessary cables from each sensor to the signal controller cabinet along signal cabling routes.

Install surge protection where coaxial video cables and other cables are required between the camera sensor and other components located in the controller cabinet. Terminate all cable conductors.

Relocate camera sensor units and reconfigure detection zones as necessary according to the plans for construction phases.

1.4 Measurement

Furnishing and/or Installing Video Imaging Loop Emulation Detection System shall be measured as EACH unit.

1.5 Payment

Furnishing and/or Installing Video Imaging Loop Emulation Detection System, measured as provided above, will be paid for at the contract unit price for:

6886039	FURNISH & INSTALL VIDEO DETECTION CAMERA MOUNTING HARDWARE	EA
6886040	FURNISH & INSTALL VIDEO DETECTION SYSTEM W/HARDWARE & LEAD-IN	EA
6886041	INSTALL VIDEO DETECTION SYSTEM	EA

Such payment shall be full compensation for installing all equipment, labor, and incidentals necessary to complete the work as specified.

Pay Item Notes

This specification is not limited to these pay items. Other pay items may be applicable.

688.5 STEEL STRAIN POLE AND FOUNDATION

1.1 Description

This work shall consist of installing and/or furnishing Steel Strain Poles, of the sizes and colors specified, and at the locations shown on the Plans, or as established by the ENGINEER. Anchor bolts and all miscellaneous hardware shall be supplied with each pole as required.

The following covers the design, fabrication and installation of steel strain poles, to be used for supporting steel cable suspended traffic signals or supporting lane control signs.

When furnishing only, Anchor bolts and all miscellaneous hardware shall be supplied with each pole as required. All anchor bolt nuts, caps, pole clamps, and miscellaneous pole hardware shall be **BAGGED IN BURLAP** for each pole. In addition, individual parts shall also be furnished as specified.

When installing, this item shall also include installing Concrete foundations with reinforcing steel, anchor bolts, ground rods, conduit elbows, and miscellaneous hardware shall be installed with each pole as required or separate.

1.2 Materials

Acceptable materials can be found on the current SCDOT Qualified Products List. Product Specifications for acceptable materials are located at http://www.scdot.org/doing/publications_Traffic.aspx

1.3 Construction

1.3.1 Foundation

The foundation shall be constructed as shown in the Design Details or the Standards. Generally, it shall be 36 inches in diameter, and at least 10 feet deep, with a circular reinforcing cage and a finished square surface above ground. The hole shall be augured (earth-auger), and the concrete poured in UN-disturbed earth. The steel pole shall not be put in place on foundation for a minimum of 2 days (48 hours after individual pour) and strain shall not be applied for a minimum of 7 days (168 hours after individual pour) or as otherwise directed by the ENGINEER. In BED-ROCK, a hole shall be jack-hammered out, and be of sufficient depth to hold the Anchor Bolts. In WET-LANDS, it may be necessary to line the hole with a heavy walled CAISSON.

The concrete shall be mixed, placed, poured, and tested in accordance with DOT Standard Specifications, Sections 701, 702, 703, and 704. The concrete provided shall be CLASS 5000. The concrete shall be placed in one continuous pour with vibration. In wet-lands or where springs are encountered the hole shall be pumped dry.

Where shown on the Plans, or as determined by the location of underground utilities, it may be necessary to excavate a hole BY HAND. NO additional payment shall be made UNLESS an item has been established in the BID or Proposal for UNCLASSIFIED EXCAVATION (hand excavation of hole) - CUBIC YARDS.

1.3.2 Anchor Bolts

The Anchor Bolts shall be set using pre-formed templates (wood or metal), to provide a "bolt-circle" in accordance with the Dimension Chart, or with recommendations of the pole Manufacturer. The templates shall be left in place for 2 days (48 hours).

1.3.3 Conduit Elbows

Conduit Elbows shall be capped at both ends, and secured in place in the excavation before any concrete is poured. The size and number of elbows shall be that necessary to mate with the incoming runs. Where no conduit is indicated on the Plans, a 2 inch elbow shall be placed for future use.

All conduit elbows shall extend beyond the side of the finished foundation by approximately 12 inches, in the direction of, and at a depth matching the incoming conduit. Where a conduit elbow is placed for future use, an "X" shall be scribed in the foundation to indicate the side where such conduit enters. The conduit shall protrude 3 inches to 6 inches above the top of the finished concrete foundation. (See Design Details or Standards.)

1.3.4 Grounding

Ground Rods and Grounding Wire shall be furnished and installed with each foundation.

The ground rod shall be configured with the foundation, as shown on the Design Details or the Standards.

Grounding clamps of brass or bronze shall be used to secure the grounding wire to the ground rod.

A continuous ground wire shall bond all metal parts together--pole ground stud; pedestal pole nut; pole-mounted controller cabinet ground; metal conduits; etc.

1.3.5 Raking

Each pole shall be raked away from the line of span wire pull, by adjusting the nuts on the Anchor Bolts.

When final load is applied, there shall be 6 inches (plus or minus one inch) rake at the top of the pole, opposing the direction of the stress.

1.3.6 Finishing

When poles are installed in SIDEWALKS, the entire "square" shall be removed, the concrete pole base installed, and the sidewalk replaced using expansion joint material to separate different "pours" and old/new concrete. This work shall be considered to be incidental, unless an item has been established for CONCRETE PATCH or for SIDEWALK. In concrete islands, a square opening 4 feet x 4 feet for the pole base, shall be saw-cut out; and finally, repaired as stated above. When installed in SIDEWALKS or CONCRETE ISLANDS, the entire area shall be contoured and hand-finished producing a neat visual line. Sharp edges or pedestrian hazards shall not be allowed.

1.3.7 Repair

Galvanized surfaces (poles) which have been scratched or abraded so that bare metal is exposed, shall be repaired by applying 2 coats of 90% (minimum) Zinc-rich, cold-galvanizing compound; to the satisfaction of the ENGINEER.

1.3.8 Warranty

The Contractor shall furnish the ENGINEER with any warranties on materials that are provided by the Manufacturer or Vendor as normal trade practice.

1.4 Measurement

Furnishing and/or installing traffic signal steel Strain Poles and Foundations, will be measured by each, of the size(s) specified, and erected in place as shown on the plans. This shall include foundation, anchor bolts, nut covers, pole cap, reinforcing steel, ground rod, ground wire, and all miscellaneous hardware as required.

Installing Concrete Foundation for Steel Strain Pole, will be measured by each, shall include reinforcing steel, ground rod, ground wire, and all miscellaneous hardware as required.

The furnishing and/or installing of Steel Monotube Signal Structures shall be measured by EACH including ALL required mounting hardware.

1.5 Payment

Furnishing and/or Installing Steel Strain Poles and Foundations, accepted, and measured as above, will be paid for at the contract unit price bid for:

682505A	FURNISH & INSTALL 13" X 26' STEEL STRAIN POLE AND FOUNDATION	EA
6825050	FURNISH & INSTALL 13" X 26' STEEL STRAIN POLE (POWDER COATED) AND FOUNDATION	EA
6825056	FURNISH & INSTALL 13" X 26' STEEL STRAIN POLE (POWDER COATED OVER GALVANIZED) AND FOUNDATION	EA
682505B	FURNISH & INSTALL 13" X 28' STEEL STRAIN POLE AND FOUNDATION	EA
6825051	FURNISH & INSTALL 13" X 28' STEEL STRAIN POLE (POWDER COATED) AND FOUNDATION	EA
6825057	FURNISH & INSTALL 13" X 28' STEEL STRAIN POLE (POWDER COATED OVER GALVANIZED) AND FOUNDATION	EA
682505D	FURNISH & INSTALL 13" X 32' STEEL STRAIN POLE AND FOUNDATION	EA
6825052	FURNISH & INSTALL 13" X 32' STEEL STRAIN POLE (POWDER COATED) AND FOUNDATION	EA
6825058	FURNISH & INSTALL 13" X 32' STEEL STRAIN POLE (POWDER COATED OVER GALVANIZED) AND FOUNDATION	EA
6888155	INSTALL STEEL STRAIN POLE ON EXISTING FOUNDATION	EA

Installing Foundation for Steel Strain Poles, accepted, and measured as above, will be paid for at the contract unit price bid for:

6887940	INSTALL FOUNDATION FOR STEEL STRAIN POLE	EA
---------	--	----

Furnishing and/or Installing Steel Monotube Signal Structures accepted, and measured as above, will be paid for at the contract unit price bid for:

6825491	FURNISH & INSTALL STEEL MONOTUBE SIGNAL STRUCTURE NUMBER (001)	EA
6825492	FURNISH & INSTALL STEEL MONOTUBE SIGNAL STRUCTURE NUMBER (002)	EA
6825493	FURNISH & INSTALL STEEL MONOTUBE SIGNAL STRUCTURE NUMBER (003)	EA
6825494	FURNISH & INSTALL STEEL MONOTUBE SIGNAL STRUCTURE NUMBER (004)	EA
6825495	FURNISH & INSTALL STEEL MONOTUBE SIGNAL STRUCTURE NUMBER (005)	EA

Which shall be full compensation for furnishing and/or installing all materials, hardware, and incidentals necessary to complete this item as specified.

Pay Item Notes

This specification is not limited to these pay items. Other pay items may be applicable.

688.6 CONCRETE STRAIN POLE

1.1 Description

This work shall consist of installing and/or furnishing pre-stressed Concrete Strain Poles, of the sizes specified, and at the locations shown on the Plans, or as established by the ENGINEER. These poles shall be of the type intended for direct embedding, with the hole back filled with concrete.

The following covers the design, fabrication and installation of pre-stressed concrete strain poles, to be used for supporting steel cable suspended traffic signals or supporting lane control signs.

1.2 Materials

Acceptable materials can be found on the current SCDOT Qualified Products List. Product Specifications for acceptable materials are located at http://www.scdot.org/doing/publications_Traffic.aspx

1.3 Construction

1.3.1 Hole

A hole shall be augured, the concrete pole lowered in and the hole back filled with concrete while being supported.

Augured Hole – The embedding foundation shall be constructed as shown in the design details or the standards. A hole shall be augured in undisturbed earth of the diameter and depth (at least) listed in the table below, or as recommended by the manufacturer (whichever is larger). The following table lists minimum values.

GENERAL USE POLE LENGTH	SPECIAL USE POLE DIAMETER	MINIMUM AUGURED HOLE DIAMETER	AUGURED HOLE DEPTH
40 FEET	12-17 INCH	36 INCH	10 FEET
45 FEET	18-23 INCH	42 INCH	11 FEET
50 FEET	24-31 INCH	48 INCH	12 FEET

The depth and diameter shall be measured by a tape measure, NOT guess work.

In bed-rock, a hole shall be jack-hammered out and be of sufficient depth to hold the design embedded length and a diameter to provide 3 inch clearance all around the concrete pole.

In wet-lands or loose-sand, it may be necessary to line the hole with a heavy walled Caisson. In Wet-lands or loose-sand, it may also be necessary to auger a larger hole.

1.3.2 Crane

CAUTION – Concrete poles are very heavy, quite long and are difficult to handle. Transportation, site handling and erection shall be performed with acceptable equipment and methods and by qualified personnel. The Contractor is cautioned to have cranes, pole trailers and sufficient manpower to perform

this work with total safety to the crew and to the motoring public. The Contractor shall review the manufacturer's shop drawings to identify proper pick-up points for lifting.

The pole shall be lifted into place, using a sling. A single point lift shall NEVER be used and such misuse could result in the ENGINEER rejecting that pole. Next, to lower the pole into the hole, a bar shall be inserted into the chocker hole (1/3 down the pole)(to prevent the strap from slipping) and a single strap shall raise one end of the pole vertically and jostle the butt end into the hole.

The pole shall be lowered into the hole and be held vertically by the crane. Using a pry bar through the "CANT" hole, the pole shall be rotated so that all holes are at the proper compass orientation angle with the street and incoming conduit runs.

Each pole shall be slightly "raked away" (leaned away) from the direction of the span wire pull. For a concrete pole this will typically mean that the back side of the pole is vertically plumb.

1.3.3 Concrete

The pole hole shall be back filled with concrete. The concrete shall be mixed, placed, poured and tested in accordance with SCDOT Standard Specifications, Sections 701, 702, 703 and 704. The concrete provided shall be CLASS 8000. The concrete shall be placed in one continuous pour. In wetlands or where springs are encountered the hole shall be pumped dry. Care shall be taken during the pour to plug/cover the underground cable entrance hole and any conduit openings.

1.3.4 Support

The concrete pole shall be vertically supported by a pole or boom truck until the poured embedding concrete begins to set. This will typically be 15 to 20 minutes. No stress (steel cables) shall be placed on the pole until the poured embedding concrete has hardened (typically 72 hours).

1.3.5 Hand Excavation

Where shown on the plans, or to determine the location of underground utilities, it may be necessary to excavate a hole by hand. No additional payment shall be made unless an item has been established in the bid or proposal for "Unclassified Excavation" (hand excavation of hole) cubic yards (meters).

1.3.6 Openings

After installation, the Contractor shall plug or cap all unused openings and couplings on the concrete pole using a threaded plug or a cemented PVC cap.

1.3.7 Conduit Elbows

Conduit elbows shall be capped at both ends and secured in place in the excavation before any concrete is poured. The site and number of elbows shall be that necessary to mate with the incoming runs.

Where the concrete pole is adjacent to a base mounted controller cabinet, then 2 - 3 inch conduits may be run to the nearby hand box (rather than 1 - 4 inch) shown in the Standards. This is due to the smaller size of the conduit opening in the concrete pole.

Where no conduit is indicated on the plans, a 2 inch elbow shall be placed for future use.

All conduit elbows shall extend beyond the side of the finished foundation by approximately 12 inches in the direction of and at a depth matching the incoming conduit.

1.3.8 Grounding

Ground rod(s) and grounding wire shall be furnished and installed with each concrete pole.

The ground rod shall be driven adjacent to the poured concrete embedding as shown on the design details or standards.

Grounding clamps of brass or bronze shall be used to secure the pole grounding wire to the grounding rod.

A continuous ground wire shall bond all metal parts together – pole ground stud, pedestal pole nut, pole mounted controller cabinet ground, metal conduits, etc.

1.3.9 Clean Up

After the pole and conduit have been installed, then the site shall be restored to prime condition. The area surrounding shall be back filled with topsoil, raked level and seeded. If the area is sloped, then landscape turf shall be used.

When poles are installed in sidewalks, the entire square shall be removed, the concrete pole installed and embedded in poured concrete, then the hole back filled with tamped dirt to 4 inches below the ground line and the sidewalk replaced using expansion joint material to separate different pours and old/new concrete. This work shall be considered to be incidental unless an item has been established for concrete patch or for sidewalk. In concrete islands, a square opening 4 feet x 4 feet for the pole base shall be saw cut out and finally repaired as stated above. When installed in sidewalks or concrete islands, the entire areas shall be contoured and hand finished producing a neat visual line. Sharp edges or pedestrian hazards shall not be allowed.

1.3.10 Repair

Concrete surfaces which have been chipped, chunked or damaged shall be patched to the satisfaction of the ENGINEER with a commercial grade vinyl or epoxy based on concrete patching compound, according to manufacturer's instructions.

Galvanized surfaces which have been scratched or abraded so that bare metal is exposed shall be repaired by applying 2 coats of 90% (minimum) zinc rich, cold galvanizing compound to the satisfaction of the ENGINEER.

1.3.11 Warranty

The Contractor shall furnish the ENGINEER with any warranties on materials that are provided by the Manufacturer or Vendor as normal trade practice.

1.4 Measurement

Furnishing and/or Installing concrete strain poles will be measured by EACH of the length specified. This shall include pole cap and all miscellaneous hardware as required.

Conduit elbows shall be considered to be incidental to the installation of the concrete pole.

1.5 Payment

Furnishing and/or Installing concrete strain poles accepted and measured as above, will be paid for at the contract unit price.

6825061	FURNISH & INSTALL 35' CONCRETE STRAIN POLE	EA
6825062	FURNISH & INSTALL 40' CONCRETE STRAIN POLE	EA
6825064	FURNISH & INSTALL 45' CONCRETE STRAIN POLE	EA
6887945	INSTALL CONCRETE STRAIN POLE	EA

Which shall be full compensation for furnishing all materials, equipment, labor and incidentals necessary to complete the work as specified.

Pay Item Notes

This specification is not limited to these pay items. Other pay items may be applicable.

688.7 CONTROLLER AND 332/336 CABINET

1.1 Description

This work shall consist of installing and/or furnishing 332/336 Cabinet Assemblies and/or Model 2070L Standard, digital, solid-state, micro-processor based, keyboard (push-button) programmable, Master/Local Controllers in: (1) POLE-, or (2) BASE- MOUNTED 332 or 336 Cabinets, in accordance with these Specifications, at the locations shown on the Plans, or directed by the ENGINEER. This item shall include all electrical accessories and other items specified.

1.2 Materials

Acceptable materials can be found on the current SCDOT Qualified Products List. Product Specifications for acceptable materials are located at http://www.scdot.org/doing/publications_Traffic.aspx

1.3 Construction

1.3.1 Concrete Foundation

The foundation shall be constructed to the dimensions shown on the Design Details or the Standards. Bolt "circle" data shall be in accordance with the recommendations of the Cabinet Manufacturer. Suitable templates for setting anchor bolts shall be accurately set and left in place until the forms are removed. Concrete lag bolts drilled into pad are allowed.

Concrete shall be mixed, placed, and tested in accordance with applicable portions of SCDOT STANDARD SPECIFICATIONS Sections 701, 702, 703, and 704. The concrete provided shall be CLASS 3000.

Base mount Cabinets shall be set in place on a bead of silicone caulk.

1.3.2 Ground Rod and Ground Wire

A ground rod and ground wire is to be furnished and installed with each Cabinet. The ground rods shall be 5/8 INCH by 8 feet (minimum) Copper-clad and shall be placed near the cabinet's concrete foundation, external to the cabinet pad. It is preferable to install the ground rod in a junction box or splice box where possible. A 1 INCH PVC conduit and elbow shall be placed in foundation prior to pouring as shown in the Design Details or the Standards. Ground wires (No. 6 AWG bare, stranded copper wire) shall run continuously from the ground rod to the Controller Cabinet (chassis ground on the AC ground bar) through this conduit; and shall run continuously from the ground rod to the foundation anchor bolts, to the conduit bends, etc. Ground wires shall be EXOTHERMICALLY WELDED TO THE GROUND ROD. Grounding bushings shall be used on metal conduit. For Cabinets mounted on strain poles, the grounding stud on the pole shall also be connected.

The entire ground rod shall be driven below the grade or place in a junction box.

1.3.3 Conduit Elbows

The conduit entering the cabinet cannot be encased in concrete. See standard detail.

Conduit Elbows shall be set in the footing excavation before the concrete is poured. The size and number shall be as shown on the Design Details or the Standards; OR shall be that necessary to mate

the incoming runs. Conduit shall extend beyond the side of the finished foundation by approximately 12 INCHES, in the direction of, and at the depth of the incoming conduit. The conduit shall extend 3 to 6 INCHES above the top of the finished foundation, inside the pole or Cabinet.

The open-ends and threads on the conduit bends shall be covered and protected during construction activities.

1.3.4 Electrical Wiring

All required equipment shall be installed in the Cabinet, and neatly wired with harnesses that have been tied or wrapped. Force-fitted or mutually interfering equipment is not acceptable. Cable harnesses and terminals shall be legibly labeled. All bare wires should be terminated in a "spade-lug" prior to connection to a terminal strip. The "spade-lug" shall be crimped-on, using a ratchet-type crimping tool. Wires not facilitating equipment movement, should be tied to the back or side-panel. Equipment should be installed and positioned for easy access. Opening and closing the Cabinet door shall not chaff the wiring.

Field (lamp) wiring shall have 3 feet of slack cable in each cabinet. The slack shall be coiled and tied neatly in the bottom of the Cabinet. Signal cables shall be separated from detector lead-in cables as much as possible, to reduce interference.

1.3.5 Warranty

The Contractor shall furnish the ENGINEER with any warranties on materials that are provided by the Manufacturer or Vendor as normal trade practice or to match warranty on existing state contract items.

1.4 Measurement

Local Controller and Cabinet furnished and/or installed will be measured by EACH TYPE Controller and Cabinet (mounting specified); and erected in place as shown on the Plans including miscellaneous electronics, load switches, wiring, electrical connection, ground rod, ground wire, and all related hardware. This includes a concrete cabinet foundation, anchor bolts and all necessary hardware.

Furnishing and/or Installing a Concrete Cabinet Foundation will be measured by EACH and will include anchor bolts and all necessary hardware.

Furnishing and/or Installing Telephone Communication will be measured by EACH and will include all modems, cables and all necessary hardware.

Furnishing Training will not be measured but will be paid for as LUMP SUM.

Furnishing Railroad Liability Insurance will be measured by EACH.

1.5 Payment

Furnishing and/or Installing Controller and/or Cabinet accepted and measured as above, will be paid for at the contract unit price.

6845510	FURNISH & INSTALL CONTROLLER AND 336 CABINET ASSEMBLY - POLE MOUNTED	EA
---------	--	----

6845511	FURNISH & INSTALL CONTROLLER AND 332/336 CABINET ASSEMBLY - BASE MOUNTED – INCLUDING FOUNDATION	EA
6888220	INSTALL CONTROLLER AND 336 CABINET - POLE MOUNTED	EA
6888225	INSTALL CONTROLLER AND 332/336 CABINET - BASE MOUNTED	EA
6888226	INSTALL CONTROLLER-BASE MOUNTED CABINET ON EXISTING FOUNDATION	EA
6845520	FURNISH & INSTALL 2070L CONTROLLER UNIT IN EXISTING CABINET	EA

Which shall be full compensation for furnishing all materials, equipment, labor and incidentals necessary to complete the work as specified.

Furnishing and/or Installing Concrete Cabinet Foundation shall be measured as above and will be paid at the line item price:

*6887951	FURNISH & INSTALL CONCRETE CABINET FOUNDATION	EA
6887950	INSTALL PREFABRICATED CONCRETE CABINET FOUNDATION	EA
6887952	INSTALL PREFORMED CABINET FOUNDATION	EA

Furnishing and/or Installing Telephone Communications shall be measured as above and will be paid at the line item price:

6800496	FURNISH & INSTALL DIGITAL SUBSCRIBER LINE FOR TRAFFIC SIGNAL	EA
6800498	FURNISH & INSTALL TELEPHONE SERVICE FOR TRAFFIC SIGNAL	EA

Furnishing Railroad Liability Insurance shall be measured as above and will be paid at the line item price:

9610201	RAILROAD LIABILITY INSURANCE	EA
---------	------------------------------	----

Which shall be full compensation for furnishing all materials, equipment, labor and incidentals necessary to complete the work as specified.

Pay Items Note

* typically used by SCDOT

This specification is not limited to these pay items. Other pay items may be applicable.

688.8 REMOTE SPLICE/FLASHER CABINET

1.1 Description

This work shall consist of installing and/or furnishing Splice Cabinet or Flasher Cabinet at remote locations and performing all related wiring necessary, in accordance with these Specifications. Many of the items necessary to create a complete installation are specified elsewhere.

See 682.1 WOOD POLE
See 680.1 ELECTRIC SERVICE
See 675.1 ELECTRICAL CONDUIT
See 677.2 COMMUNICATION CABLE
See 677.1 ELECTRICAL CABLE

A Splice/Flasher Cabinet will usually be located remote from the nearest signalized intersection.

1.2 Materials

1.2.1 Cabinet

The Cabinet furnished shall meet the requirements stated in the Specification for "TRAFFIC SIGNAL CABINETS", TYPE 2, herein; with the specific features listed below:

1.2.1.1 Type

Aluminum; TYPE 2--The minimum approximate size shall be approximately 70 cm (27 in) High X 38 cm (15 in) Wide X 30 cm (12in) Deep.

1.2.1.2 Design

The Cabinet shall be designed for pole or pedestal-pole mounting. It shall be furnished with all related corrosion resistant hardware, including top and bottom mounting brackets, or pole-hub. Straps used shall be stainless steel.

1.2.1.3 Door

Hinged; full weather-tight gaskets; #2 rustproof cylinder lock with key.

1.2.1.4 Vent

Required.

1.2.2 Flasher Cabinet Features

Circuit breaker, 15 amp; radio-frequency line filter; lightning arrester; 120 VAC GFI duplex convenience outlet; fluorescent or incandescent lamp with switch; NEMA Standard 2-circuit Flasher, and other equipment necessary to complete the flasher installation. Plus terminal strips and grounding buss as necessary.

1.2.3 Splice Cabinet Features

The Cabinet shall have the number of terminal BLOCKS sufficient to connect the incoming and outgoing interconnection cables of pairs each; in accordance with the Manufacturers recommendations; plus terminal STRIPS for all grounds, commons, or other connections. Terminal Blocks shall be telephone quality, R66 "Quick-Connect M-type", having pairs capability, and use a "Stand-Off Mounting". All cables and terminals shall be clearly identified (labeled).

1.2.4 Schematic

There shall be furnished three (3) copies of the complete electrical schematic diagram for each Splice/Flasher Cabinet.

1.2.5 Conduit

Conduit elbows, fittings, and risers shall meet the specifications stated in FURNISH AND INSTALL ELECTRICAL CONDUIT.

1.2.6 Miscellaneous

All components or hardware shall be made of corrosion-resistant material, or be of the same materials as the item being installed.

1.3 Construction

1.3.7 Mounting

The Cabinet shall be mounted as shown in the Design Details or the Standards Drawings.

1.3.8 Wiring

Electrical cables shall be connected to the terminals in accordance with the signal equipment Manufacturer recommendations. GROUNDING AND SURGE/LIGHTNING PROTECTION SHALL BE PROVIDED in every Splice Cabinet (unless specifically forbidden by the Manufacturer). The Protector shall be Telephone Company grade, and be conformable with the Terminal Block specified in Paragraph 1.1.F. When operated as part of a signal system, any additional protection required by *these* Manufacturers shall be included, with particular attention to On-Street Masters, Remote Communication Units, or connections to a Central Traffic Computer. The cable shield shall be grounded.

A No. 6 AWG bare stranded copper Ground Wire shall run continuously from the Cabinet to the ground rod at the pole base. Where design requires, a new ground rod shall be driven; and a ground wire installed from the Cabinet to the ground rod.

1.3.9 Warranty

The Contractor shall furnish the ENGINEER with any warranties on materials that are provided by the Manufacturer or Vendor as normal trade practice or to match warranty on existing state contract items.

1.4 Measurement

Furnishing and/or Installing Remote Splice Cabinet or Flasher Cabinet, shall be measured by EACH housing, erected and placed as shown on the Plans, including miscellaneous electronics, electrical connections, etc. NOTE: The furnishing, installation, and payment of the conduit, poles, electrical service, and other major items are specified elsewhere.

1.5 Payment

Furnishing and/or Installing Remote Splice Cabinet or Flasher Cabinet, accepted and measured as provided above, will be paid at the contract unit price bid for:

6845655	FURNISH & INSTALL SPLICE-CABINET/FLASHER CABINET	EA
6888245	INSTALL SPLICE-CABINET / FLASHER-CABINET	EA

which shall be full compensation for furnishing all materials, equipment, labor, and incidentals necessary to complete the work as specified.

Pay Item Notes

This specification is not limited to these pay items. Other pay items may be applicable.

688.9 SOLAR POWERED FLASHER ASSEMBLY

1.1 Description

This work shall consist of installing and/or furnishing a Solar Powered Flasher Assembly and performing all related wiring necessary, in accordance with these Specifications.

1.2 Materials

Acceptable materials can be found on the current SCDOT Qualified Products List. Product Specifications for acceptable materials are located at http://www.scdot.org/doing/publications_Traffic.aspx

1.3 Construction

1.3.1 24/7 Single Solar 24 Hour Flashing Beacon

1.3.1.1 Mounting

Each individual component, the solar engine, signal housing and LED module, shall be provided with hardware for mounting to one of the following pole types. If the sign is larger than 36 inches, then two posts shall be used.

- 2" square perforated tubing
- 2 3/8" diameter round sign post
- 4.5" Round
- 4" x 4" wood post

All Pedestrian Bases shall include Anchor Bolts.

1.3.2 24/7 Single Compact Solar 24 Hour Flashing Beacon

1.3.2.1 Mounting

The entire assembly, including solar engine, signal housing and LED module shall be provided with hardware for mounting on to the top of one of the following pole types. If the sign is larger than 36 inches, then two posts shall be used.

- 2" square perforated tubing
- 2 3/8" diameter round sign post
- 4.5" Round
- 4" x 4" wood post

The entire assembly shall mount at one point. Separate mounting for the signal head or any other component shall not be required. All Pedestrian Bases shall include Anchor Bolts.

1.3.3 Dual 24 Hour Solar Powered Flashing Beacon

1.3.3.1 Mounting

The entire assembly, including solar engine, signal housing and LED modules shall be provided with hardware for mounting on to one of the following pole types. If the sign is larger than 36 inches, then two posts shall be used.

- 2" square perforated tubing

- 2 3/8" diameter round sign post
- 4 1/2" diameter round sign post
- 4" x 4" or larger square wood post
- Side-of-pole arm

All Pedestrian Bases shall include Anchor Bolts.

1.3.4 Dual Solar Powered School Flashing Beacon

1.3.4.1 Mounting

Each component including solar engine, signal housing, LED modules, etc. shall be provided with hardware for mounting on to one of the following pole types. If the sign is larger than 36 inches, then two posts shall be used.

- 2" square perforated tubing
- 2 3/8" diameter round sign post
- 4.5" Round
- 4" x 4" wood post
- Side-of-pole arm

All Pedestrian Bases shall include Anchor Bolts.

1.3.5 Dual Compact Solar School Zone Flasher

1.3.5.1 Mounting

The entire assembly, including solar engine, signal housing and LED modules shall be provided with hardware for mounting to one of the following pole types. If the sign is larger than 36 inches, then two posts shall be used.

- 2" square perforated tubing
- 2 3/8" diameter round sign post
- 4.5" Round
- 4" x 4" wood post
- Side-of-pole arm

All Pedestrian Bases shall include Anchor Bolts.

1.4 Measurement

Furnishing and/or Installing a Solar Powered Flasher Assembly, shall be measured by EACH, erected and placed as shown on the Plans, which shall include all electrical connections and all required incidental hardware.

1.5 Payment

Furnishing and/or Installing a Solar Powered Flasher Assembly, accepted and measured as provided above, will be paid at the contract unit price bid for:

6865700	FURNISH & INSTALL SOLAR POWERED FLASHER ASSEMBLY - SINGLE BEACON	EA
6865701	FURNISH & INSTALL SOLAR POWERED FLASHER ASSEMBLY - DUAL BEACON	EA
6865702	FURNISH & INSTALL SOLAR POWERED FLASHER ASSEMBLY	EA
6887960	INSTALL SOLAR POWERED FLASHER ASSEMBLY	EA

which shall be full compensation for furnishing all materials, equipment, labor, and incidentals necessary to complete the work as specified.

Pay Item Notes

This specification is not limited to these pay items. Other pay items may be applicable.

689.1 WORKING CREW WITH EQUIPMENT

1.1 Description

This item shall consist of performing work for the SCDOT, on a per hour bases for equipment and labor. This will include the contractor furnishing a crew of four persons, one bucket truck, one line truck and one foreman’s vehicle to be worked at the line item price for working crew with equipment. The crew will need to be able to perform duties in the field of traffic signal installation and revisions. This item will be used for emergency calls and unforeseen work which cannot be predicted and there is no pay for. All work under this item, shall be approved by the ENGINEER, prior to engaging in any work where this item may be used. The ENGINEER reserves the right to refuse or engage this item. While engaged in this line item, there shall be no other line engaged by the contractor. The ENGINEER reserves the right to engage Primary Traffic Control while working under this line item. Engaging in any other line items in this contract while working under this line item will need the approval of the ENGINEER.

1.2 Construction

All work performed under this item shall have written approval from the ENGINEER before engaging in any work under this item. This item is to be used when there are unforeseen problems such as wet holes, borrowing roadways, rock holes and any other deemed problems or emergencies. In case of an emergency, the ENGINEER will call the CONTRACTOR in line for assistance with the installation or maintenance of an intersection, in this case both parties must agree on engaging this item. The ENGINEER will issue a work order and grant permission in writing to engage in this item.

1.3 Measurement

Working Crew With Equipment will be measured per HOUR.

1.4 Payment

Working Crew With Equipment accepted and measured as provided above, will be paid at the contract unit price bid for:

6887990	WORKING CREW WITH EQUIPMENT	HR
---------	-----------------------------	----

Payment for working crew with equipment will be made per work order for the total hours worked on that work order. If the work order begins after the normal workday or on the weekend, time can be charged at a rate of 1 ½ times pay per hour. This extra pay rate must be agreed on between the contractor and the ENGINEER prior to beginning work.

Pay Item Notes

This specification is not limited to these pay items. Other pay items may be applicable.

689.2 SYSTEM INTEGRATION AND TESTING

1.1 Description

This work consists of providing the personnel, equipment and technical support to test the traffic signal equipment prior to installation on the street; and to connect all equipment; to program operating parameters; and to make the traffic signal system totally operational.

1.2 Materials

1.2.1 GENERAL

1.2.1.1 Personnel

THIS IS A "TURN-KEY" PROJECT", WITH THE CONTRACTOR PERFORMING -ALL- ACTIVITIES. The CONTRACTOR shall be capable of performing, or shall obtain the services of a TRAFFIC SIGNAL INTEGRATION SPECIALIST (or other technically trained persons) to accomplish all items in this Specification. Department personnel will NOT perform this service for the Contractor.

1.2.1.2 License

Being a third party, it is the responsibility of the CONTRACTOR TO SECURE THE SOFTWARE LICENSE to permit legitimate Contractor use of the firmware and software used by the system. This LICENSE may be written to include training for Contractor personnel.

1.2.2 SYSTEM INTEGRATION

1.2.2.1 Installation, Assembly, and Connection

The TRAFFIC SIGNAL INTEGRATION SPECIALIST shall provide complete Closed Loop SYSTEM INTEGRATION. This shall include connecting all signal equipment and making it totally operational. This shall also include verification of communication and closed loop operation from the Central Monitoring Facility computer. Where the computer is being provided by the signal system project, this shall include assembly and connection of the computer and peripheral equipment.

1.2.2.2 Programming

The TRAFFIC SIGNAL INTERATION SPECIALIST shall program the central computer, controllers and master(s) with their associated operating/timing parameters. The initial timing values will be provided as design requires. This work shall include the primary programming of "traffic responsive" parameters, where applicable. These persons shall create and furnish the customized COLOR GRAPHICS DISPLAYS required by the system. This shall include an intersection DRAWING/GRAPHIC for each signal and creating system display(s) for the signals controlled by each separate field master.

1.2.3 SYSTEM TESTING

The TRAFFIC SIGNAL INTERATION SPECIALIST shall provide pre-installation cabinet and controller TESTING in accordance with these requirements. The tests shall provide full hookup electrical testing and communication verification. The test period shall extend uninterrupted for (7) seven days for a signal system and (3) three days for an isolated signal or group of signals that will **NOT** be interconnected in any way. These tests shall be conducted in a climate controlled (indoor /heat /AC) TEST BUILDING, that is

provided by the CONTRACTOR. The Building shall be complete with desk, chairs, two telephone lines, 120 VAC outlets, overhead lighting, a rest room, and at a convenient location to be approved by the Department. The TEST BUILDING shall be open to the Department, the Municipality, or the Federal Highway Administration and the test shall be witnessed by the Department. This shall also include storage until the equipment is needed on the street. The certified equipment shall then be transported to work site by the CONTRACTOR.

1.3 Measurement

This item shall not be measured but paid as LUMP SUM.

1.4 Payment

All costs associated with these programming, testing, and systems integration activities, and with securing the software License, making the entire system complete and operational to the satisfaction of the Engineer shall be paid at the Contract Unit Price bid for--

6886010	INTEGRATION	LS
---------	-------------	----

This item shall be paid on a prorated LUMP SUM basis, being:

- Twenty five (25%) percent with the first monthly estimate;
- Fifty (50%) percent when the contract dollar amount reaches fifty percent of the total contract; and the final
- Twenty five (25%) percent following successful FINAL INSPECTION and conditional acceptance of the traffic signal project, (or of the traffic signal equipment alone, when it is part of a road project).

Pay Item Notes

This specification is not limited to these pay items. Other pay items may be applicable.

689.3 TRAFFIC SIGNAL SYSTEM TRAINING

1.1 Description

This work consists of providing Traffic Signal System Training.

1.2 Materials

1.2.1 General

The **CONTRACTOR** shall provide complete training for **DEPARTMENT** and maintaining agency personnel and representatives in the operation and maintenance of the traffic signal system components. The training program shall consist of formal classroom lectures and "hands-on" workshops with central and field equipment. The **CONTRACTOR** shall provide all personnel and instructors necessary for providing all training. The instructors shall be employees of the manufacturer(s) of the traffic signal system components, or approved equal.

All training classes must be completed prior to the beginning of any system/intersection operational testing. Training classes shall not overlap without prior approval of the Resident Construction Engineer. Training class schedules shall be consistent with the working schedules of the class attendees. Training shall only be scheduled on weekdays; and training days shall generally consist of six (6) to eight (8) hours.

The **CONTRACTOR** shall develop and provide all necessary training materials, aids, and manuals.

The **CONTRACTOR** shall provide training and training materials for up to 15 people in each training class. The Resident Construction Engineer shall provide a listing of the expected trainees for each training session, when the proposed training materials are approved.

As part of the **CONTRACT** materials submission requirements, the **CONTRACTOR** shall submit for approval copies of all training program subjects, training materials, aids, manuals, class agendas, class schedules (includes dates and times) and training locations. All submission materials must be approved by the Resident Construction Engineer before permission to begin training is given.

1.2.2 Training Program Subjects

The **CONTRACTOR** shall provide training on the subjects listed in the special provisions. Below is a description of the kinds of training that may be required. The **CONTRACTOR** shall address the theory of operation and the technical and practical aspects of each component. Specific and thorough attention should be afforded to day-to-day operation, programming, testing, fault-diagnosis and repair of each component. Training related to specific hardware components shall include hands-on demonstrations utilizing sample components identical to those components installed in the field. Training on the proper use of specific tools utilized during installation, testing, and maintenance of various system components shall be addressed. Training classes on the following subjects shall be provided. Minimum required class durations are given in parentheses.

1.2.2.1 Local Intersection Controller Assemblies

This subject shall include all pertinent information required for the programming, operation and maintenance of the local intersection controller assemblies. This information shall include diagnostic and repair procedures. This information shall include but shall not be limited to: local intersection controller;

conflict monitor; controller cabinet assembly; and, intersection loop detectors. Manual and computer field programming shall be addressed. The **CONTRACTOR** may expect that class attendees will have basic, general knowledge of traffic controller equipment. (8 hours)

1.2.2.2 Internal Local Coordinator

Local -To- On-Street Master Communications.

On-Street Master Assemblies.

On-Street Master -To- Central System Communications.

This subject shall include all pertinent information required for the programming, operation, and maintenance of the on-street traffic signal system components. This information shall include diagnostic and repair procedures. This information shall include but shall not be limited to: internal local coordination unit; on-street master controller unit; and all communication systems and communication hardware including local telemetry units, any radio components, and on-street auto-dial/auto-answer external communications modems. Manual and computer field programming shall be addressed. The **CONTRACTOR** shall expect that class attendees will have no previous experience of knowledge regarding this subject. (16 hours)

1.2.2.3 Central Control Center Equipment

This subject shall include all pertinent information required for the operation and maintenance of the Central Control Center Equipment. This information shall include basic operation of the central microcomputer assembly, monitor, printer, and auto-dial/auto answer external communications modem equipment including various diagnostic/trouble-shooting tools available to the computer user. The **CONTRACTOR** shall expect that class attendees will have a basic familiarity with MS-DOS personal computer systems, but no other specific experience or knowledge regarding this subject. (4 hours)

1.2.2.4 Traffic Signal System Central Software / Firmware

This subject shall include all pertinent information required for the operation of the traffic signal system and the development of the traffic signal system database. The pertinent information shall include all aspects of operation of the central software programs. This information shall also include complete and thorough training on the system database and the necessary information to be input into the on-street equipment to give the desired on-street operation. This information shall include all local controller programming and operation as it impacts the operation of the local controllers within the system. This information shall include all programming of the local intersection coordination parameters and on-street master controller units for all modes of coordinated system operation. This information shall include all specific system database structure and parameters and the inter-relations between different types of system data. The **CONTRACTOR** shall expect that class attendees will have basic experience and knowledge of local intersection and coordination system timing and operation but shall not expect specific familiarity with the products of the system of the manufacturer being installed. (16 hours)

1.2.2.5 Synchro

This subject shall include all pertinent information required to use the newest version of Trafficware Synchro Studio. This will include classroom training using actual software. (32 hours)

1.2.2.6 Traffic Adaptive

This subject shall include all pertinent information required for the operation of the traffic signal system in adaptive mode. The pertinent information shall include all aspects of operation of the central software programs and the local controller. (16 hours)

1.2.2.7 Traffic Responsive

This subject shall include all pertinent information required for the operation of the traffic signal system in responsive mode. The pertinent information shall include all aspects of operation of the central software programs and the local controller. (16 hours)

1.2.3 **Acceptance of Training**

Within 7 calendar days of the completion of each training class, the Resident Construction Engineer shall provide acceptance or non-acceptance of the training program. If the training program is not accepted, the **CONTRACTOR** shall correct the deficiencies in the training program and provide again the necessary class(es) at his expense. Acceptance of system training of each training program subject will be based on the following criteria:

- Thoroughness and completeness of instructional coverage of the training program subject;
- Thoroughness and appropriateness of the training program subject materials, including class demonstration and audio/visual aids, to the instructional coverage; and,
- Class instructor's ability to answer class attendees and clarify training material to the satisfaction of the class attendees.

The DEPARTMENT reserves the right to halt an ongoing class, if that class will clearly not be accepted.

For all training classes that are not acceptable, the Resident Construction Engineer shall provide specific information on which specific training classes are not acceptable and why within 7 calendar days of the completion of each training class. Within 15 calendar days of notification of non-acceptance of the training program, the **CONTRACTOR** shall submit for approval revised training program materials that correct the deficiencies in the non-accepted training classes. These materials shall clearly demonstrate the **CONTRACTOR's** revisions to the training program and shall include a new training program schedule. All of the **CONTRACTOR's** requirements and responsibilities for the original training program shall be borne by the **CONTRACTOR**. Once the revised training program is approved, the **CONTRACTOR** shall again provide the training classes for the original class attendees or specific substitutes for original attendees. The **CONTRACTOR** is only responsible for providing subsequent training classes for those classes that were not accepted as part of the original training program.

1.3 **Measurement**

This item shall be measured and paid on an HOURLY rate.

1.4 Payment

Training shall be paid for at the Contract price bid for the item established for:

6886020	TRAINING BEING SIGNAL RELATED SYSTEM TRAINING	HR
---------	---	----

to be paid at the conclusion of the training, which shall be full compensation for the provision of signal system training, including all materials and incidentals to perform the work as specified.

Pay Item Notes

This specification is not limited to these pay items. Other pay items may be applicable.

690.1 STEEL POLE WITH MAST-ARM

1.1 Description

This work shall consist of designing (foundations, lengths of arms, size of support arms), installing and/or furnishing Steel Traffic Signal Poles with Mast-Arm(s). Concrete footings with reinforcing steel, anchor bolts, ground rods, conduit elbows, and miscellaneous hardware shall be designed and installed with each pole as required. **Steel mast-arm poles, its components, adapter plates and foundations shall be stamped and sealed by a licensed South Carolina Professional Engineer.**

1.2 Materials

1.2.1 Design Criteria

1.2.1.1 AASHTO Standards

The Mast-Arm traffic signal Pole shall meet the requirements of the "Standard Specifications for Structural Supports for Highway Signs, Luminaires, and Traffic Signals"; American Association of State Highway And Transportation Officials (AASHTO), 2001 edition and 2002 interim supplement. All components of the Mast-Arm Pole assemblies shall be designed to the following:

- 25-year mean recurrence interval
- Basic wind speed (See attached map for SC Coastal Region wind zone requirements and/or AASHTO Section 3.8.2, Figure 3-2)
- Ice load included
- Fatigue category II
- Natural wind gust pressure loads included
- Truck-induced gust pressure loads included

1.2.1.2 Minimum Assumptions

For design, traffic signal heads shall be assumed to be one-way, twelve-inch, aluminum, and be rigidly attached. For design purposes, it shall be assumed that, at the end of the Mast-Arm, there is mounted a five-section cluster signal; and, depending on arm length, three-section signals at twelve feet and at twenty-four feet toward the Pole-Shaft. Signs shall be assumed next to each signal. The traffic signs assumed shall be 30 x 36 inches, and shall be rigidly attached.

1.2.2 Design Requirements

1.2.2.1 Anchor Bolts

With each steel pole with mast arms, provide hooked anchor bolts at least 90 inches long. The top 12 inches of the anchor bolt shall be threaded and hot dipped galvanized. (2) hot dipped galvanized nuts and (2) washers per anchor bolt shall be provided.

1.2.2.2 Adapter Plate

Note: Adapter plate(s), bolts, nuts, and washers not required if steel pole with mast arm is designed to be supported by current SCDOT signal foundation (concrete foundation with (4) 2" dia. anchor bolts on a 18-inch dia. bolt circle), and the design meets the design criteria requirements of this specification.

With each steel pole with mast arms, provide a 2" thick, hot dipped galvanized steel adapter to allow a pole with a 19" square base plate and 18" dia. bolt circle to be installed. Plate shall be pre-drilled with (4) 2 3/8" dia. bolt holes on the 18" dia. bolt circle. A 10" dia. minimum hole shall be provided in the center of the adapter plate.

Provide (4) hot dipped galvanized 2" x 10" hex head cap screws, (12) nuts, and (8) washers in a **BURLAP** bag for each adapter plate. Bolts and nuts shall be of sufficient strength to support a 32-foot tall steel pole with steel strain wire supporting signal heads and signs for the intersection in case the steel pole with mast arms is damaged and has to be removed and replaced.

Adapter plate(s), bolt, and nut selection and design shall be stamped and sealed by a licensed South Carolina Professional Engineer.

1.2.2.3 Mast Arm Vertical Clearance

Unless otherwise shown on the plans, the bottom of the overhead traffic signal mast arm shall provide a minimum vertical clearance over the entire width of the pavement and shoulders of 22'-0".

1.2.2.4 Miscellaneous Items

Steel pole with mast arms design drawing shall include the following:

- 4" x 6" minimum reinforced handhole,
- 1/2" coarse thread grounding stud located on interior of pole handhole,
- strain relief j-hook at top of pole, rain cap,
- holes in steel poles and mast arms for wiring to be routed to traffic signals,
- holes for wiring to be protected with full circumference grommets,
- nut covers to be provided to cover anchor bolt nuts,
- tapered poles and mast arms shall taper uniformly along their length
- additional requirements as shown on the signal plans for the intersections

1.2.3 **Other Materials**

Other materials shall meet the following requirements:

1.2.3.1 Concrete

The concrete used in the pole base shall meet the design by the foundation designer, and shall conform to the requirements of SCDOT STANDARD SPECIFICATIONS FOR HIGHWAY CONSTRUCTION, Section 701, 702, 703, and 704.

1.2.3.2 Reinforcing Steel

Steel reinforcement shall conform to the requirements of SCDOT STANDARD SPECIFICATIONS FOR HIGHWAY CONSTRUCTION, Section 703.2.1.

The bars shall be of the size and type shown on the Design Details or in the Standards.

1.2.3.3 Conduit Elbow

Conduit Elbows shall be in accordance with FURNISH AND INSTALL ELECTRICAL CONDUIT. Conduit Elbows shall be installed in pole bases before pouring and shall be PVC, of the size and type shown on the Plans. As a minimum, THERE SHALL BE AT LEAST TWO CONDUIT ELBOW (2 INCH PVC ELBOW) IN EACH POLE BASE. End of conduit shall protrude above top of pole base 6-9 inches.

1.2.3.4 Grounding

Ground rods shall be 5/8 inch by 8 feet (minimum) Copper-Clad. A No. 6 AWG bare, stranded copper wire shall be used in the ground connection. EACH POLE SHALL HAVE ONE (1) GROUND ROD (minimum). An adequate ground shall be developed per NEC.

1.2.3.5 Signal Brackets

Unless otherwise shown on the plans, rigid signal head mounting brackets shall be used. The bracket shall consist of a top- and bottom-arm, an extruded aluminum vertical tube, a vertical tube clamp, and a mast-arm clamp, with all hardware. The Bracket shall be COMPLETELY RUST PROOF, and shall be fully adjustable in all dimensions and angles.

1.2.3.6 Sign Brackets

Where required by the Plans, each sign mounting bracket shall be of the commercial type shown on the Installation Details or the Standards. The bracket shall be rust proof.

1.2.3.7 Miscellaneous

All other hardware or components shall be made of a non-corrosive material, or be of the same material as the item being installed.

1.2.4 ***Design And Drawings***

The CONTRACTOR SHALL FURNISH pole design details, calculations, and shop-drawings in sufficient detail for complete evaluation and comparison with these Specifications. Any exceptions to these Specifications must be stated in writing. The design, calculations, and shop drawings shall be stamped and sealed by a licensed South Carolina Professional Engineer.

The CONTRACTOR SHALL FURNISH a concrete foundation design details and calculations adequate for local soil type and steel pole with mast arm loads shall be designed. The design and calculations shall be stamped and sealed by a licensed South Carolina Professional Engineer.

NOTE: CATALOG CUTS ARE REQUIRED FOR REVIEW AND APPROVAL PRIOR TO FABRICATION.

1.2.5 ***Powdercoating***

Color to be specified in Special Provisions. Two types – powdercoat over base or powdercoat over galvanized.

1.2.6 ***Decorative***

Type to be specified in Special Provisions

1.2.7 ***Luminaire***

Generally requires a taller pole, per Standard Drawing or as noted in Special Provisions or Signal Plans. Luminaire to be furnished and/or installed must be provided by the same manufacturer as the mast arm, unless noted otherwise. Luminaire design and/or color should match mast arm design and/or color.

1.2.8 *Warranty*

The CONTRACTOR shall furnish the Engineer with all warranties on equipment and material offered by the Manufacturer as normal trade practice.

1.3 **Construction**

1.3.1 *Foundation*

The foundation shall be constructed with a circular reinforcing cage (**either tied together, or tack welded**) installed. The finished square surface above ground shall be as shown on the Installation Details or the Standards. The hole shall be augured (earth-auger), and the concrete poured in UN-disturbed earth. **The steel pole shall not be put in place on foundation for a minimum of two (2) days (48 hours after individual pour) and mast-arm or strain shall not be applied for a minimum of seven (7) days (168 hours after individual pour) or as otherwise directed by the project engineer.**

The concrete shall be mixed, placed, poured, and tested in accordance with DOT Standard Specifications, Sections 701, 702, 703, 704. The concrete shall be placed in one continuous pour. The hole shall be pumped dry in wet-lands.

Where shown on the Plans, or as determined by the location of underground utilities, it may be necessary to excavate a hole BY HAND. No additional payment shall be made.

1.3.2 *Anchor Bolts*

The Anchor Bolts shall be set using pre-formed templates (wood or metal), to provide a "bolt-circle" in accordance with the requirements in 2.1 above. **The templates shall be left in place for two (2) days (48 hours).**

1.3.3 *Conduit Elbows*

Conduit Elbows shall be capped at both ends, and secured in place in the excavation before any concrete is poured. The size and number of elbows shall be that necessary to mate with the incoming runs. Where no conduit is indicated on the Plans, a two (2") inch PVC elbow shall be placed for future use.

All conduit elbows shall extend beyond the side of the finished foundation by approximately twelve (12") inches, in the direction of, and at a depth matching the incoming conduit. Where a conduit elbow is placed for future use, an "X" shall be scribed in the foundation to indicate the side where such conduit enters. The conduit shall protrude six to nine (6"-9") inches above the top of the finished concrete foundation.

1.3.4 *Grounding*

Ground Rods and Grounding Wire shall be furnished and installed with each foundation.

The ground rod shall be configured with the foundation, as shown on the Design Details or the Standards.

Grounding clamps of brass or bronze shall be used to secure the grounding wire to the ground rod.

A continuous ground wire shall bond all metal parts together--pole ground stud; pedestal pole nut; pole-mounted controller cabinet ground; metal conduits; etc.

1.3.5 Adapter Plate

The adapter plate, if required, shall be placed between the leveling nuts and the steel pole with mast arms base.

The **BURLAP** bag containing the adapter plate nuts, bolts, and washers shall be placed inside each steel pole with mast arms.

1.3.6 Raking

Each Pole shall be raked away from the line of the Mast-Arm pull, by adjusting the nuts on the anchor bolts.

When final load is applied, there shall be an essentially vertical appearance as determined by the Engineer.

1.3.7 Finishing

When poles are installed in SIDEWALKS, the entire "square" shall be removed, the concrete pole base installed, and the sidewalk replaced using expansion joint material to separate different "pours" and old/new concrete. This work shall be considered to be incidental, unless an item has been established for CONCRETE PATCH or for SIDEWALK. In concrete islands, a square opening 4 ft x 4 ft for the pole base, shall be saw-cut out; and finally, repaired as stated above. When installed in SIDEWALKS or CONCRETE ISLANDS, the entire area shall be contoured and hand-finished to produce a neat visual line. Sharp edges or pedestrian hazards shall not be allowed.

1.3.8 Repair

Poles which have been scratched or abraded so that bare metal is exposed, shall be repaired to the satisfaction of the Engineer. Holes drilled in poles or Mast-Arms shall likewise be repaired.

1.4 Measurement

Design and/or furnish and/or installing traffic signal steel Poles with Mast Arm will be measured by each, erected in place as shown on the plans. This shall include Adapter Plates (if applicable), Foundation, Concrete, Anchor Bolts, Nut Covers, Pole Cap, reinforcing steel, ground rod, ground wire, and all miscellaneous hardware as required.

1.5 Payment

Design and/or Furnish and/or Install Steel Poles with Mast Arm, accepted, and measured as above, will be paid for at the contract unit price bid for:

6888179	DESIGN, FURNISH & INSTALL STEEL POLE WITH MAST ARM INCLUDING FOUNDATION	EA
6888172	DESIGN, FURNISH & INSTALL STEEL POLE WITH MAST ARM WITHOUT FOUNDATION	EA
6888177	DESIGN, FURNISH & INSTALL STEEL POLE WITH TWIN MAST ARMS INCLUDING FOUNDATION	EA
6888178	DESIGN, FURNISH & INSTALL STEEL POLE WITH TWIN MAST ARMS WITHOUT FOUNDATION	EA
6888170	INSTALL STEEL POLE WITH MAST ARM INCLUDING FOUNDATION	EA
6888171	INSTALL STEEL POLE WITH MAST ARM WITHOUT FOUNDATION	EA
6888180	INSTALL STEEL POLE WITH TWIN MAST ARMS INCLUDING FOUNDATION	EA
6888181	INSTALL STEEL POLE WITH TWIN MAST ARMS WITHOUT FOUNDATION	EA
6888173	SOIL BORING - UTILITY REVIEW FOR MAST ARM DESIGN PER QUADRANT	EA
6888174	INSTALL FOUNDATION FOR MAST ARM INCLUDING CONCRETE AND REBAR	CY
6888163	DESIGN MAST ARM FOUNDATION	EA
6888164	FURNISH & INSTALL DUAL LUMINAIRE INCLUDING LUMINAIRE ARMS AND ALL ASSOCIATED HARDWARE	EA
6888165	FURNISH & INSTALL SINGLE LUMINAIRE INCLUDING LUMINAIRE ARMS AND ALL ASSOCIATED HARDWARE	EA
6888110	INSTALL STREET LIGHT LUMINAIRE	EA
6888166	POWDERCOATING PER MAST ARM OVER BASE	EA
6888167	POWDERCOATING PER MAST ARM OVER GALVANIZED	EA
6888168	DECORATIVE OPTION PER MAST ARM	EA
6888169	LUMINAIRE OPTION FOR MAST ARM - TO ACCOUNT FOR TALLER POLE	EA
6513020	FURNISH & INSTALL MOUNTING ASSEMBLY FOR FLAT SHEET SIGN ERCTD ON MAST ARM	EA
6865831	FURNISH & INSTALL VEHICLE TRAFFIC SIGNAL HEAD MOUNTING ASSEMBLY FOR MAST ARM	EA
6750262	FURNISH & INSTALL ENCASED CONDUIT (2-2" PVC, SCHEDULE 40)	LF
6750263	FURNISH & INSTALL ENCASED CONDUIT (3-2" PVC, SCHEDULE 40)	LF

The following pay items will be used only when the Engineer has designed full mast arm plans and will be paid for at the contract unit price bid for:

6825110	FURNISH & INSTALL 21' STEEL POLE WITH 26' MAST ARM INCLUDING FOUNDATION	EA
6825111	FURNISH & INSTALL 21' STEEL POLE WITH 28' MAST ARM INCLUDING FOUNDATION	EA
6825112	FURNISH & INSTALL 21' STEEL POLE WITH 30' MAST ARM INCLUDING FOUNDATION	EA
6825113	FURNISH & INSTALL 21' STEEL POLE WITH 32' MAST ARM INCLUDING FOUNDATION	EA

	FOUNDATION	
6825114	FURNISH & INSTALL 21' STEEL POLE WITH 34' MAST ARM INCLUDING FOUNDATION	EA
6825115	FURNISH & INSTALL 21' STEEL POLE WITH 36' MAST ARM INCLUDING FOUNDATION	EA
6825116	FURNISH & INSTALL 21' STEEL POLE WITH 38' MAST ARM INCLUDING FOUNDATION	EA
6825117	FURNISH & INSTALL 21' STEEL POLE WITH 40' MAST ARM INCLUDING FOUNDATION	EA
6825118	FURNISH & INSTALL 21' STEEL POLE WITH 42' MAST ARM INCLUDING FOUNDATION	EA
6825119	FURNISH & INSTALL 21' STEEL POLE WITH 44' MAST ARM INCLUDING FOUNDATION	EA
682511A	FURNISH & INSTALL 21' STEEL POLE WITH 46' MAST ARM INCLUDING FOUNDATION	EA
682511B	FURNISH & INSTALL 21' STEEL POLE WITH 48' MAST ARM INCLUDING FOUNDATION	EA
682511C	FURNISH & INSTALL 21' STEEL POLE WITH 50' MAST ARM INCLUDING FOUNDATION	EA
682511D	FURNISH & INSTALL 21' STEEL POLE WITH 52' MAST ARM INCLUDING FOUNDATION	EA
682511E	FURNISH & INSTALL 21' STEEL POLE WITH 54' MAST ARM INCLUDING FOUNDATION	EA
682511F	FURNISH & INSTALL 21' STEEL POLE WITH 56' MAST ARM INCLUDING FOUNDATION	EA
682511G	FURNISH & INSTALL 21' STEEL POLE WITH 58' MAST ARM INCLUDING FOUNDATION	EA
682511H	FURNISH & INSTALL 21' STEEL POLE WITH 60' MAST ARM INCLUDING FOUNDATION	EA
6825120	FURNISH & INSTALL 27' STEEL POLE WITH 26' MAST ARM INCLUDING FOUNDATION	EA
6825121	FURNISH & INSTALL 27' STEEL POLE WITH 28' MAST ARM INCLUDING FOUNDATION	EA
6825122	FURNISH & INSTALL 27' STEEL POLE WITH 30' MAST ARM INCLUDING FOUNDATION	EA
6825123	FURNISH & INSTALL 27' STEEL POLE WITH 32' MAST ARM INCLUDING FOUNDATION	EA
6825124	FURNISH & INSTALL 27' STEEL POLE WITH 34' MAST ARM INCLUDING FOUNDATION	EA
6825125	FURNISH & INSTALL 27' STEEL POLE WITH 36' MAST ARM INCLUDING FOUNDATION	EA
6825126	FURNISH & INSTALL 27' STEEL POLE WITH 38' MAST ARM INCLUDING FOUNDATION	EA
6825127	FURNISH & INSTALL 27' STEEL POLE WITH 40' MAST ARM INCLUDING FOUNDATION	EA
6825128	FURNISH & INSTALL 27' STEEL POLE WITH 42' MAST ARM INCLUDING FOUNDATION	EA
6825129	FURNISH & INSTALL 27' STEEL POLE WITH 44' MAST ARM INCLUDING FOUNDATION	EA
682512A	FURNISH & INSTALL 27' STEEL POLE WITH 46' MAST ARM INCLUDING FOUNDATION	EA

682512B	FURNISH & INSTALL 27' STEEL POLE WITH 48' MAST ARM INCLUDING FOUNDATION	EA
682512C	FURNISH & INSTALL 27' STEEL POLE WITH 50' MAST ARM INCLUDING FOUNDATION	EA
682512D	FURNISH & INSTALL 27' STEEL POLE WITH 52' MAST ARM INCLUDING FOUNDATION	EA
682512E	FURNISH & INSTALL 27' STEEL POLE WITH 54' MAST ARM INCLUDING FOUNDATION	EA
682512F	FURNISH & INSTALL 27' STEEL POLE WITH 56' MAST ARM INCLUDING FOUNDATION	EA
682512G	FURNISH & INSTALL 27' STEEL POLE WITH 58' MAST ARM INCLUDING FOUNDATION	EA
682512H	FURNISH & INSTALL 27' STEEL POLE WITH 60' MAST ARM INCLUDING FOUNDATION	EA
682512J	FURNISH & INSTALL 27' STEEL POLE WITH 64' MAST ARM INCLUDING FOUNDATION	EA
682512K	FURNISH & INSTALL 27' STEEL POLE WITH 66' MAST ARM INCLUDING FOUNDATION	EA
682512M	FURNISH & INSTALL 27' STEEL POLE WITH 70' MAST ARM INCLUDING FOUNDATION	EA
6825130	FURNISH & INSTALL 21' STEEL POLE WITH TWIN MAST ARMS (26'X26')AT 90 DEG. INCLUDING FOUNDATION	EA
6825131	FURNISH & INSTALL 21' STEEL POLE WITH TWIN MAST ARMS (26'X28')AT 90 DEG. INCLUDING FOUNDATION	EA
6825132	FURNISH & INSTALL 21' STEEL POLE WITH TWIN MAST ARMS (26'X30')AT 90 DEG. INCLUDING FOUNDATION	EA
6825133	FURNISH & INSTALL 21' STEEL POLE WITH TWIN MAST ARMS (26'X32')AT 90 DEG. INCLUDING FOUNDATION	EA
6825134	FURNISH & INSTALL 21' STEEL POLE WITH TWIN MAST ARMS (26'X34')AT 90 DEG. INCLUDING FOUNDATION	EA
6825136	FURNISH & INSTALL 21' STEEL POLE WITH TWIN MAST ARMS (26'X38')AT 90 DEG. INCLUDING FOUNDATION	EA
6825137	FURNISH & INSTALL 21' STEEL POLE WITH TWIN MAST ARMS (26'X40')AT 90 DEG. INCLUDING FOUNDATION	EA
6825138	FURNISH & INSTALL 21' STEEL POLE WITH TWIN MAST ARMS (26'X42')AT 90 DEG. INCLUDING FOUNDATION	EA
6825139	FURNISH & INSTALL 21' STEEL POLE WITH TWIN MAST ARMS (26'X44')AT 90 DEG. INCLUDING FOUNDATION	EA
682513A	FURNISH & INSTALL 21' STEEL POLE WITH TWIN MAST ARMS (26'X46')AT 90 DEG. INCLUDING FOUNDATION	EA
682513B	FURNISH & INSTALL 21' STEEL POLE WITH TWIN MAST ARMS (26'X48')AT 90 DEG. INCLUDING FOUNDATION	EA
682513C	FURNISH & INSTALL 21' STEEL POLE WITH TWIN MAST ARMS (26'X50')AT 90 DEG. INCLUDING FOUNDATION	EA
682513D	FURNISH & INSTALL 21' STEEL POLE WITH TWIN MAST ARMS (26'X52')AT 90 DEG. INCLUDING FOUNDATION	EA
682513E	FURNISH & INSTALL 21' STEEL POLE WITH TWIN MAST ARMS (26'X54')AT 90 DEG. INCLUDING FOUNDATION	EA
682513F	FURNISH & INSTALL 21' STEEL POLE WITH TWIN MAST ARMS (26'X56')AT 90 DEG. INCLUDING FOUNDATION	EA
682513G	FURNISH & INSTALL 21' STEEL POLE WITH TWIN MAST ARMS (26'X58')AT 90 DEG. INCLUDING FOUNDATION	EA

	INCLUDING FOUNDATION	
682513H	FURNISH & INSTALL 21' STEEL POLE WITH TWIN MAST ARMS (26'X60')AT 90 DEG. INCLUDING FOUNDATION	EA
6825140	FURNISH & INSTALL 21' STEEL POLE WITH TWIN MAST ARMS (28'X28')AT 90 DEG. INCLUDING FOUNDATION	EA
6825141	FURNISH & INSTALL 21' STEEL POLE WITH TWIN MAST ARMS (28'X30')AT 90 DEG. INCLUDING FOUNDATION	EA
6825142	FURNISH & INSTALL 21' STEEL POLE WITH TWIN MAST ARMS (28'X32')AT 90 DEG. INCLUDING FOUNDATION	EA
6825143	FURNISH & INSTALL 21' STEEL POLE WITH TWIN MAST ARMS (28'X34')AT 90 DEG. INCLUDING FOUNDATION	EA
6825144	FURNISH & INSTALL 21' STEEL POLE WITH TWIN MAST ARMS (28'X36')AT 90 DEG. INCLUDING FOUNDATION	EA
6825145	FURNISH & INSTALL 21' STEEL POLE WITH TWIN MAST ARMS (28'X38')AT 90 DEG. INCLUDING FOUNDATION	EA
6825146	FURNISH & INSTALL 21' STEEL POLE WITH TWIN MAST ARMS (28'X40')AT 90 DEG. INCLUDING FOUNDATION	EA
6825147	FURNISH & INSTALL 21' STEEL POLE WITH TWIN MAST ARMS (28'X42')AT 90 DEG. INCLUDING FOUNDATION	EA
6825148	FURNISH & INSTALL 21' STEEL POLE WITH TWIN MAST ARMS (28'X44')AT 90 DEG. INCLUDING FOUNDATION	EA
6825149	FURNISH & INSTALL 21' STEEL POLE WITH TWIN MAST ARMS (28'X46')AT 90 DEG. INCLUDING FOUNDATION	EA
682514A	FURNISH & INSTALL 21' STEEL POLE WITH TWIN MAST ARMS (28'X48')AT 90 DEG. INCLUDING FOUNDATION	EA
682514B	FURNISH & INSTALL 21' STEEL POLE WITH TWIN MAST ARMS (28'X50')AT 90 DEG. INCLUDING FOUNDATION	EA
682514C	FURNISH & INSTALL 21' STEEL POLE WITH TWIN MAST ARMS (28'X52')AT 90 DEG. INCLUDING FOUNDATION	EA
682514D	FURNISH & INSTALL 21' STEEL POLE WITH TWIN MAST ARMS (28'X54')AT 90 DEG. INCLUDING FOUNDATION	EA
682514E	FURNISH & INSTALL 21' STEEL POLE WITH TWIN MAST ARMS (28'X56')AT 90 DEG. INCLUDING FOUNDATION	EA
682514F	FURNISH & INSTALL 21' STEEL POLE WITH TWIN MAST ARMS (28'X58')AT 90 DEG. INCLUDING FOUNDATION	EA
682514G	FURNISH & INSTALL 21' STEEL POLE WITH TWIN MAST ARMS (28'X60')AT 90 DEG. INCLUDING FOUNDATION	EA
6825150	FURNISH & INSTALL 21' STEEL POLE WITH TWIN MAST ARMS (30'X30')AT 90 DEG. INCLUDING FOUNDATION	EA
682515F	FURNISH & INSTALL 21' STEEL POLE WITH TWIN MAST ARMS (30'X60')AT 90 DEG. INCLUDING FOUNDATION	EA
6825160	FURNISH & INSTALL 21' STEEL POLE WITH TWIN MAST ARMS (32'X32')AT 90 DEG. INCLUDING FOUNDATION	EA
682516E	FURNISH & INSTALL 21' STEEL POLE WITH TWIN MAST ARMS (32'X60')AT 90 DEG. INCLUDING FOUNDATION	EA
6825170	FURNISH & INSTALL 21' STEEL POLE WITH TWIN MAST ARMS (34'X34')AT 90 DEG. INCLUDING FOUNDATION	EA
682517D	FURNISH & INSTALL 21' STEEL POLE WITH TWIN MAST ARMS (34'X60')AT 90 DEG. INCLUDING FOUNDATION	EA
6825180	FURNISH & INSTALL 21' STEEL POLE WITH TWIN MAST ARMS (36'X36')AT 90 DEG. INCLUDING FOUNDATION	EA

682518C	FURNISH & INSTALL 21' STEEL POLE WITH TWIN MAST ARMS (36'X60')AT 90 DEG. INCLUDING FOUNDATION	EA
6825190	FURNISH & INSTALL 21' STEEL POLE WITH TWIN MAST ARMS (38'X38')AT 90 DEG. INCLUDING FOUNDATION	EA
682519B	FURNISH & INSTALL 21' STEEL POLE WITH TWIN MAST ARMS (38'X60')AT 90 DEG. INCLUDING FOUNDATION	EA
6825200	FURNISH & INSTALL 21' STEEL POLE WITH TWIN MAST ARMS (40'X40')AT 90 DEG. INCLUDING FOUNDATION	EA
6825201	FURNISH & INSTALL 21' STEEL POLE WITH TWIN MAST ARMS (40'X42')AT 90 DEG. INCLUDING FOUNDATION	EA
6825202	FURNISH & INSTALL 21' STEEL POLE WITH TWIN MAST ARMS (40'X44')AT 90 DEG. INCLUDING FOUNDATION	EA
6825203	FURNISH & INSTALL 21' STEEL POLE WITH TWIN MAST ARMS (40'X46')AT 90 DEG. INCLUDING FOUNDATION	EA
6825204	FURNISH & INSTALL 21' STEEL POLE WITH TWIN MAST ARMS (40'X48')AT 90 DEG. INCLUDING FOUNDATION	EA
6825205	FURNISH & INSTALL 21' STEEL POLE WITH TWIN MAST ARMS (40'X50')AT 90 DEG. INCLUDING FOUNDATION	EA
6825206	FURNISH & INSTALL 21' STEEL POLE WITH TWIN MAST ARMS (40'X52')AT 90 DEG. INCLUDING FOUNDATION	EA
6825207	FURNISH & INSTALL 21' STEEL POLE WITH TWIN MAST ARMS (40'X54')AT 90 DEG. INCLUDING FOUNDATION	EA
6825208	FURNISH & INSTALL 21' STEEL POLE WITH TWIN MAST ARMS (40'X56')AT 90 DEG. INCLUDING FOUNDATION	EA
6825209	FURNISH & INSTALL 21' STEEL POLE WITH TWIN MAST ARMS (40'X58')AT 90 DEG. INCLUDING FOUNDATION	EA
682520A	FURNISH & INSTALL 21' STEEL POLE WITH TWIN MAST ARMS (40'X60')AT 90 DEG. INCLUDING FOUNDATION	EA
6825210	FURNISH & INSTALL 21' STEEL POLE WITH TWIN MAST ARMS (42'X42')AT 90 DEG. INCLUDING FOUNDATION	EA
6825219	FURNISH & INSTALL 21' STEEL POLE WITH TWIN MAST ARMS (42'X60')AT 90 DEG. INCLUDING FOUNDATION	EA
6825220	FURNISH & INSTALL 21' STEEL POLE WITH TWIN MAST ARMS (44'X44')AT 90 DEG. INCLUDING FOUNDATION	EA
6825228	FURNISH & INSTALL 21' STEEL POLE WITH TWIN MAST ARMS (44'X60')AT 90 DEG. INCLUDING FOUNDATION	EA
6825230	FURNISH & INSTALL 21' STEEL POLE WITH TWIN MAST ARMS (46'X46')AT 90 DEG. INCLUDING FOUNDATION	EA
6825237	FURNISH & INSTALL 21' STEEL POLE WITH TWIN MAST ARMS (46'X60')AT 90 DEG. INCLUDING FOUNDATION	EA
6825240	FURNISH & INSTALL 21' STEEL POLE WITH TWIN MAST ARMS (48'X48')AT 90 DEG. INCLUDING FOUNDATION	EA
6825246	FURNISH & INSTALL 21' STEEL POLE WITH TWIN MAST ARMS (48'X60')AT 90 DEG. INCLUDING FOUNDATION	EA
6825250	FURNISH & INSTALL 21' STEEL POLE WITH TWIN MAST ARMS (50'X50')AT 90 DEG. INCLUDING FOUNDATION	EA
6825255	FURNISH & INSTALL 21' STEEL POLE WITH TWIN MAST ARMS (50'X60')AT 90 DEG. INCLUDING FOUNDATION	EA
6825260	FURNISH & INSTALL 21' STEEL POLE WITH TWIN MAST ARMS (52'X52')AT 90 DEG. INCLUDING FOUNDATION	EA
6825264	FURNISH & INSTALL 21' STEEL POLE WITH TWIN MAST ARMS (52'X60')AT 90 DEG. INCLUDING FOUNDATION	EA

	INCLUDING FOUNDATION	
6825270	FURNISH & INSTALL 21' STEEL POLE WITH TWIN MAST ARMS (54'X54')AT 90 DEG. INCLUDING FOUNDATION	EA
6825273	FURNISH & INSTALL 21' STEEL POLE WITH TWIN MAST ARMS (54'X60')AT 90 DEG. INCLUDING FOUNDATION	EA
6825280	FURNISH & INSTALL 21' STEEL POLE WITH TWIN MAST ARMS (56'X56')AT 90 DEG INCLUDING FOUNDATION.	EA
6825282	FURNISH & INSTALL 21' STEEL POLE WITH TWIN MAST ARMS (56'X60')AT 90 DEG. INCLUDING FOUNDATION	EA
6825290	FURNISH & INSTALL 21' STEEL POLE WITH TWIN MAST ARMS (58'X58')AT 90 DEG. INCLUDING FOUNDATION	EA
6825291	FURNISH & INSTALL 21' STEEL POLE WITH TWIN MAST ARMS (58'X60')AT 90 DEG. INCLUDING FOUNDATION	EA
6825295	FURNISH & INSTALL 21' STEEL POLE WITH TWIN MAST ARMS (60'X60')AT 90 DEG. INCLUDING FOUNDATION	EA
6825310	FURNISH & INSTALL 27' STEEL POLE WITH TWIN MAST ARMS (26'X26')AT 90 DEG. INCLUDING FOUNDATION	EA
682531H	FURNISH & INSTALL 27' STEEL POLE WITH TWIN MAST ARMS (26'X60')AT 90 DEG. INCLUDING FOUNDATION	EA
6825320	FURNISH & INSTALL 27' STEEL POLE WITH TWIN MAST ARMS (28'X28')AT 90 DEG. INCLUDING FOUNDATION	EA
682532G	FURNISH & INSTALL 27' STEEL POLE WITH TWIN MAST ARMS (28'X60')AT 90 DEG. INCLUDING FOUNDATION	EA
6825330	FURNISH & INSTALL 27' STEEL POLE WITH TWIN MAST ARMS (30'X30')AT 90 DEG. INCLUDING FOUNDATION	EA
682533F	FURNISH & INSTALL 27' STEEL POLE WITH TWIN MAST ARMS (30'X60')AT 90 DEG. INCLUDING FOUNDATION	EA
6825340	FURNISH & INSTALL 27' STEEL POLE WITH TWIN MAST ARMS (32'X32')AT 90 DEG. INCLUDING FOUNDATION	EA
682534E	FURNISH & INSTALL 27' STEEL POLE WITH TWIN MAST ARMS (32'X60')AT 90 DEG. INCLUDING FOUNDATION	EA
6825350	FURNISH & INSTALL 27' STEEL POLE WITH TWIN MAST ARMS (34'X34')AT 90 DEG. INCLUDING FOUNDATION	EA
682535D	FURNISH & INSTALL 27' STEEL POLE WITH TWIN MAST ARMS (34'X60')AT 90 DEG. INCLUDING FOUNDATION	EA
6825360	FURNISH & INSTALL 27' STEEL POLE WITH TWIN MAST ARMS (36'X36')AT 90 DEG. INCLUDING FOUNDATION	EA
682536C	FURNISH & INSTALL 27' STEEL POLE WITH TWIN MAST ARMS (36'X60')AT 90 DEG. INCLUDING FOUNDATION	EA
6825370	FURNISH & INSTALL 27' STEEL POLE WITH TWIN MAST ARMS (38'X38')AT 90 DEG. INCLUDING FOUNDATION	EA
682537B	FURNISH & INSTALL 27' STEEL POLE WITH TWIN MAST ARMS (38'X60')AT 90 DEG. INCLUDING FOUNDATION	EA
6825380	FURNISH & INSTALL 27' STEEL POLE WITH TWIN MAST ARMS (40'X40')AT 90 DEG. INCLUDING FOUNDATION	EA
682538A	FURNISH & INSTALL 27' STEEL POLE WITH TWIN MAST ARMS (40'X60')AT 90 DEG. INCLUDING FOUNDATION	EA
6825390	FURNISH & INSTALL 27' STEEL POLE WITH TWIN MAST ARMS (42'X42')AT 90 DEG. INCLUDING FOUNDATION	EA
6825399	FURNISH & INSTALL 27' STEEL POLE WITH TWIN MAST ARMS (42'X60')AT 90 DEG. INCLUDING FOUNDATION	EA

6825400	FURNISH & INSTALL 27' STEEL POLE WITH TWIN MAST ARMS (44'X44')AT 90 DEG. INCLUDING FOUNDATION	EA
6825408	FURNISH & INSTALL 27' STEEL POLE WITH TWIN MAST ARMS (44'X60')AT 90 DEG. INCLUDING FOUNDATION	EA
6825410	FURNISH & INSTALL 27' STEEL POLE WITH TWIN MAST ARMS (46'X46')AT 90 DEG. INCLUDING FOUNDATION	EA
6825417	FURNISH & INSTALL 27' STEEL POLE WITH TWIN MAST ARMS (46'X60')AT 90 DEG. INCLUDING FOUNDATION	EA
6825420	FURNISH & INSTALL 27' STEEL POLE WITH TWIN MAST ARMS (48'X48')AT 90 DEG. INCLUDING FOUNDATION	EA
6825426	FURNISH & INSTALL 27' STEEL POLE WITH TWIN MAST ARMS (48'X60')AT 90 DEG. INCLUDING FOUNDATION	EA
6825430	FURNISH & INSTALL 27' STEEL POLE WITH TWIN MAST ARMS (50'X50')AT 90 DEG. INCLUDING FOUNDATION	EA
6825435	FURNISH & INSTALL 27' STEEL POLE WITH TWIN MAST ARMS (50'X60')AT 90 DEG. INCLUDING FOUNDATION	EA
6825440	FURNISH & INSTALL 27' STEEL POLE WITH TWIN MAST ARMS (52'X52')AT 90 DEG. INCLUDING FOUNDATION	EA
6825444	FURNISH & INSTALL 27' STEEL POLE WITH TWIN MAST ARMS (52'X60')AT 90 DEG. INCLUDING FOUNDATION	EA
6825450	FURNISH & INSTALL 27' STEEL POLE WITH TWIN MAST ARMS (54'X54')AT 90 DEG. INCLUDING FOUNDATION	EA
6825453	FURNISH & INSTALL 27' STEEL POLE WITH TWIN MAST ARMS (54'X60')AT 90 DEG. INCLUDING FOUNDATION	EA
6825460	FURNISH & INSTALL 27' STEEL POLE WITH TWIN MAST ARMS (56'X56')AT 90 DEG. INCLUDING FOUNDATION	EA
6825462	FURNISH & INSTALL 27' STEEL POLE WITH TWIN MAST ARMS (56'X60')AT 90 DEG. INCLUDING FOUNDATION	EA
6825470	FURNISH & INSTALL 27' STEEL POLE WITH TWIN MAST ARMS (58'X58')AT 90 DEG. INCLUDING FOUNDATION	EA
6825471	FURNISH & INSTALL 27' STEEL POLE WITH TWIN MAST ARMS (58'X60')AT 90 DEG. INCLUDING FOUNDATION	EA
6825475	FURNISH & INSTALL 27' STEEL POLE WITH TWIN MAST ARMS (60'X60')AT 90 DEG. INCLUDING FOUNDATION	EA

Which shall be full compensation for furnishing and installing all materials, and incidentals necessary to complete this item as specified.

Pay Item Notes

This specification is not limited to these pay items. Other pay items may be applicable.

2001 AASHTO Design Specification Form

Name: _____ Title: _____

Organization: _____ Phone #: _____

Project Site Location: _____ , _____

1. **Basic Wind Speed** – AASHTO Section 3.8.2 and Figure 3-2 _____ mph
(See Attached Map)

2. **Design Life or Recurrence Interval** – AASHTO Section 3.8.3 and Table 3-3 recommends the following design life intervals for various structure types and locations, unless otherwise specified by the owner. (check one only)
 - _____ 10 years for roadside sign structures.
 - _____ 25 years for luminaire support structures less the 49.2' in height and signal structures where locations and safety considerations permit, and when approved by the owner. (* SCDOT minimum standard*)
 - _____ 50 years for luminaire support structures exceeding 49.2' in height and overhead sign structures.
 - _____ 100 years for critical locations.

3. **Fatigue Category** – AASHTO Section 11.6 and Table 11-1 (check one only)
 - _____ Category I For critical cantilevered support structures installed on major highways, which present a high hazard in the event of failure.
 - _____ Category II For all cantilevered support structures installed on major highways and all cantilevered support structures installed on secondary highways. (* SCDOT minimum standard*)
 - _____ Category III For cantilevered support structures installed at all other locations.

4. **Galloping loads** – AASHTO Section 11.7.1 (check one only)
 - _____ Design cantilevered support structures to resist periodic galloping forces.
 - _____ Do not design cantilevered support structures to resist periodic galloping forces. An owner approved mitigation device will be attached to each structure. Mitigation device shall be the sole responsibility of the owner.
 - _____ Do not design cantilevered support structures to resist periodic galloping forces. The owner will install an approved mitigation device only if a structure displays a galloping problem. The mitigation device must be installed as quickly as possible after the galloping problem appears. (* SCDOT minimum standard*)

5. **Truck loads** – AASHTO Section 11.7.4 (check one only)
 - _____ Include truck-induced gust loads. The specified average truck speed is _____ mph. _____ AASHTO equations are based on a truck speed of 65 mph, but also allow for a design pressure reduction for lower speeds. (* SCDOT minimum standard*)
 - _____ Do not include truck-induced gust loads as allowed by the owner.

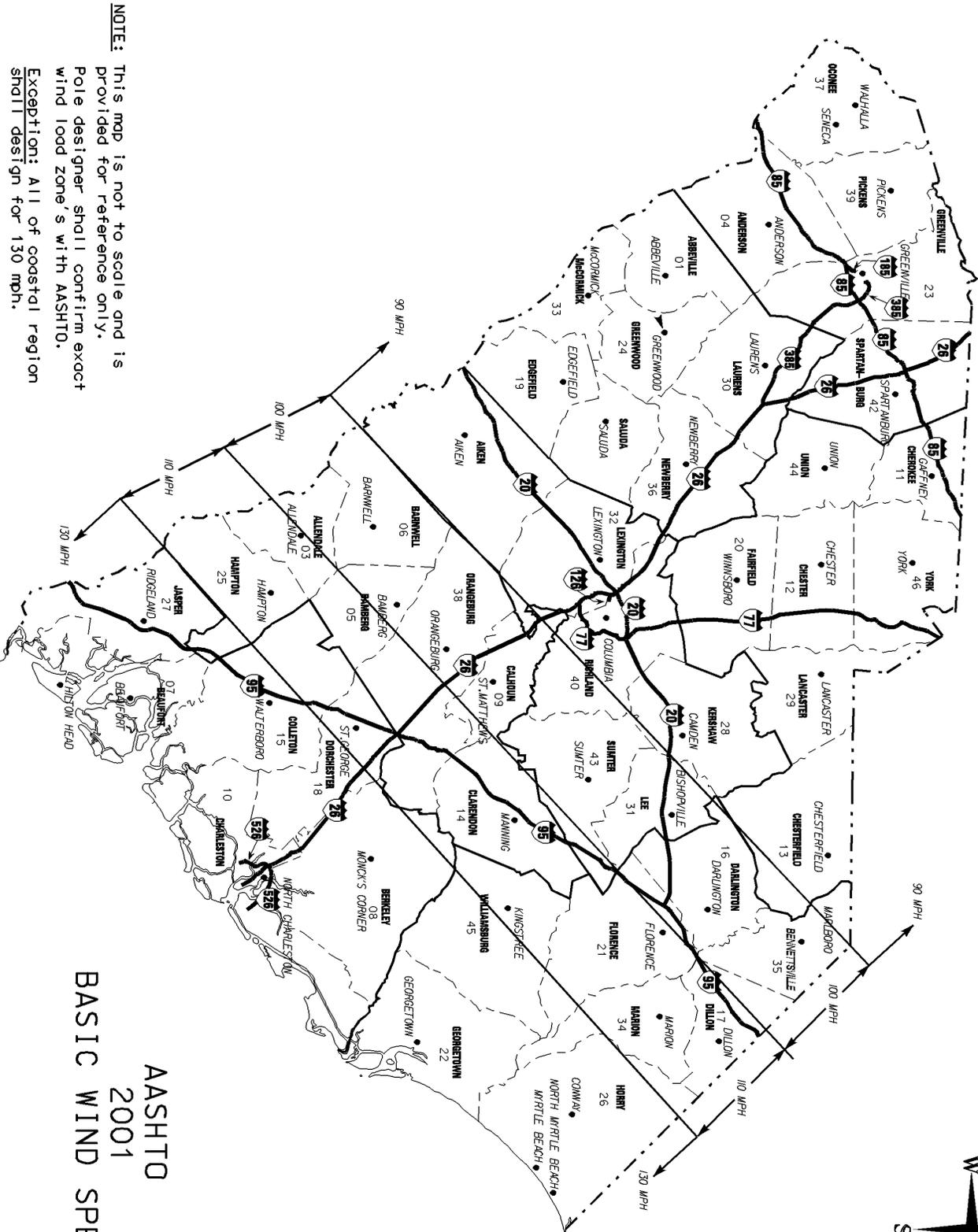

NOTE: This map is not to scale and is provided for reference only. Pole designer shall confirm exact wind load zone's with AASHTO.

**AASHTO
2001
BASIC WIND SPEEDS**

Exception: All of coastal region shall design for 130 mph.

NO SCALE

SCDOT TRAFFIC SIGNAL SPECIAL PROVISIONS FOR DESIGN BUILD PROJECTS

S.C. FILE NO:

PROJECT NO:

COUNTY

1. LIST OF TRAFFIC SIGNALS WITHIN PROJECT

Intersection No.	Intersection Name	Description of Signal Work

2. PROJECT DESCRIPTION

- a. This Project is a Design-Build construction project and involves the signal construction of ____ intersections along _____ in and around the city of _____, South Carolina. The intersections involved are shown on the above "List of Traffic Signals within Project".
- b. Specific Description of the signal work:

Below is more information concerning any changes, revisions, or clarifications to the SCDOT Traffic Signal Supplemental Specifications and/or pay items for this particular contract:

103.1 Mobilization

Work Order Contract: Includes all necessary mobilization items for one work order and shall be paid one time per work order. Once work order includes work at one traffic signal. If installing fiber or other communications, one work order would not exceed 2500 linear feet of fiber.

Design-Bid-Build Contract: Includes all work as a lump sum cost.



103.2 Mobilization of Material

675.1 Electrical Conduit

676.1 Fiber Optic Training

676.2 Fiber Optic Test Equipment

677.1 Electrical Cable

677.2 Communication Cable

677.3 Fiber Optic Cable

677.4 Fiber Interconnect Center

677.5 Fiber Optic Modem

677.6 Factory Terminated Patch Panel

677.7 Spread Spectrum Radio Assembly

678.1 Detector Loop

680.1 Electric Service

680.2 Splice Box/Junction Box

682.1 Wood Pole

682.2 Back Guy

682.3 Steel Cable

682.4 Pedestrian Pole and Base

686.1 LED Modules and/or Polycarbonate Vehicle Signal Head and/or Backplate

686.2 Optically Programmable Vehicle Signal Head

686.3 Pedestrian Signal Head

686.4 Pedestrian Push Button Station Assembly with Sign

686.5 Symbolic LED Blankout Sign

688.1 Removal Salvage and Disposal of Equipment and Materials

688.2 Temporary Adjustment of Traffic Signal Equipment and Timings

688.3 Video Detection – Loop Emulation System

688.5 Steel Strain Pole and Foundation

688.6 Concrete Strain Pole

688.7 Controller and 332/336 Cabinet

688.8 Remote Splice/Flasher Cabinet

688.9 Solar Powered Flasher Assembly

689.2 System Integration and Testing

689.3 Traffic Signal System Training

690.1 Steel Pole with Mast-Arm

3. QUANTITY LISTS

This is a lump sum design build project. No quantities are provided in this contract.

4. EQUIPMENT

- a. SCDOT Supplied Equipment - The Department will not furnish any signal equipment..
- b. Contractor Supplied Equipment
 - i. The CONTRACTOR shall furnish all **new** equipment, including incidental items; used, refurbished equipment will not be accepted.
 - ii. Compatibility
 1. To insure compatibility, any additional equipment required during the life of this contract, as Change Order or Extra Work, shall be purchased by the CONTRACTOR from the same Manufacturer as the original item.
 2. When installing equipment such as signal heads or pedestrian equipment, where some existing equipment is being retained, the contractor shall provide the same type of equipment, as is remaining, for visual compatibility.
 - iii. The CONTRACTOR shall submit for approval a list of equipment including make, model number, manufacturer serial numbers, and warranty information, in a format similar to chart below. The chart shows a list of potential furnished signal equipment. Documentation only has to be submitted for the furnish items required for this contract At the time of such submission, the CONTRACTOR shall provide a copy of the Transmittal Letter, to the Engineer.

Item	Make	Model #	Manufacturer	Is item on current QPL or is item under current SCDOT equipment contract (y or n)	If no, is cut sheet attached (y or n)	Serial #'s attached	Warranty info attached	Purchase date	Purchase invoice attached
Electrical Cable									
Communication Cable									
Fiber Optic Cable									
Fiber Interconnect Center / Fiber Splice Trays									
Loop Wire and Sealant									
Splice Boxes / Junction Boxes									
Steel Cable									
Vehicle Signal Head with LED Modules									
LED Blank Out Signs									
Optically Programmable Vehicle Signal Head									
Pedestrian Signal Head									
Pedestrian Push Button Station Assembly									
Steel Strain Pole									
Mast Arm									
Concrete Strain Pole									
Controllers and 332/336 Cabinets									
Spread Spectrum Radio Assembly									
Ethernet Extender									
Video Detection Systems									

- iv. If equipment is on the SCDOT Equipment Contract or the SCDOT QPL, catalog cut sheets do not have to be provided. On all other equipment, the CONTRACTOR shall submit for approval, catalog descriptions and documentation--THREE (3) COPIES--for each class of signal equipment and materials furnished by the CONTRACTOR. They are to be submitted TWO WEEKS PRIOR TO INSTALLATION to the Construction Office FOR APPROVAL. At the time of such submission, the CONTRACTOR shall provide a copy of the Transmittal Letter, to the Engineer.
- v. Equipment substitutions in the life of the contract are only allowed if the contractor can show a valid hardship in remaining with the originally submitted equipment. A valid hardship may include drastic price increases, non-availability of type of equipment due to unforeseen delivery or material shortages (contractor ordering equipment late does not apply), vendor going out of business, etcetera. SCDOT may allow equipment substitutions if product is of better quality than originally submitted or if contractor is replacing non-QPL items with QPL or SCDOT Equipment Contract items, or if equipment is experimental in nature and SCDOT wants to test said equipment.
- vi. SCDOT will not pay for furnish and or installation costs of any materials installed without prior approval and acceptance, in accordance with iii and iv above.

5. GENERAL PROVISIONS -

- a. All work under this Contract shall be performed under: the SOUTH CAROLINA DEPARTMENT OF TRANSPORTATION, "STANDARD SPECIFICATIONS FOR HIGHWAY CONSTRUCTION", Latest Edition; the SCDOT SUPPLEMENTAL SPECIFICATIONS FOR TRAFFIC SIGNALS; the SCDOT STANDARD DRAWINGS; these SCDOT TRAFFIC SIGNAL SPECIAL PROVISIONS; the "MANUAL ON UNIFORM TRAFFIC CONTROL DEVICES FOR STREETS AND HIGHWAYS" (latest revision); the SCDOT TRAFFIC SIGNAL DESIGN GUIDELINES; and the PLANS.
- b. Unless noted otherwise on the plans or in these Special Provisions this is a "turn-key" project, with the contractor furnishing and installing all equipment, complete and operational to the satisfaction of the Engineer.
- c. The PLANS are schematic in nature, showing what is generally expected at each intersection. The CONTRACTOR must devise/refine the final details, working within the Supplemental Specifications, the Design Details, the Standards, and with the Engineer.
- d. Any deviation from the Plans must be approved by the Engineer.
- e. At Project completion all traffic signals/equipment shall be complete and operational, to the satisfaction of the Engineer.
- f. The CONTRACTOR will install the traffic signal to provide a completely modern installation.
- g. Notifications
Prior to beginning construction, the CONTRACTOR shall participate in a "Pre-Construction Conference" at a time and place to be scheduled by the Department's Resident Construction Engineer (RCE).
- h. Unauthorized Work
Any work performed without notification of the proper parties in the Department, will be treated as unauthorized work (see Section 105.11 of the Standard Specifications), and could result in nonpayment to the CONTRACTOR for that work.
- i. Power
The CONTRACTOR, prior to the beginning of any construction activity, shall coordinate as necessary with the Utility Company supplying the power for this project. A representative of the Utility Company should be present at the RCE's Pre-Construction Conference.
- j. Maintenance during construction
The contractor shall be responsible for the maintenance and operation of all existing signals in the project, until the final acceptance of the project. Final acceptance occurs 60 days after all punch list items are completed and signal is accepted by SCDOT. This shall include all daily maintenance of signals and any emergencies which may arise. There is no separate pay item for maintenance during construction; maintenance is simply part of the construction process. Additional details on maintenance responsibility are found in these Special Provisions, *Section 10 Maintenance of Operations* and in *the SCDOT Traffic Signal Supplemental Specifications, 688.2 Temporary Adjustment of Traffic Signal Equipment and Timings*.

6. PERMITS, CODES, LICENSES, & ABILITIES –

- a. All work shall be done in a workmanlike manner to meet the highest industry standards, all in accordance with the requirements of the latest editions of the National Electrical Code (NEC), the National Electrical Safety Code (NESC), the Illuminating Engineering Society (IES), the American National Standards Institute (ANSI), the National Electrical Manufacturer's Association (NEMA), and the regulations and standards of the local power company.
- b. The prime contractor or subcontractor responsible for the performance of the work covered by these SCDOT TRAFFIC SIGNAL SPECIAL PROVISIONS **must be licensed by the SC Licensing Board For**

Contractors and possess a Journeyman Card issued by the South Carolina Municipal Association or as required by the city in which work occurs at the time work is performed.

- c. Further, at least one 'ON-SITE' field supervisor shall have LEVEL II or higher, Traffic Signal Certification by the International Municipal Signal Association (IMSA). Photo copies of the license and certificate (for both above) shall be submitted before work commences. The CONTRACTOR shall retain employee(s) holding the above certificate for the duration of the project; and the employee(s) shall be present **DAILY** and at the **FINAL INSPECTION**.
- d. The CONTRACTOR shall employ persons capable of programming traffic signal controllers of the type used by this project. The CONTRACTOR shall possess both a desktop and a portable (laptop) computer, and be capable of using them to upload and download signal operating parameters.
- e. In addition to the state requirements, all permits and licenses required by a City/County are the responsibility of the CONTRACTOR. The CONTRACTOR shall arrange with the utility company for hookup connections and attachment agreements.

7. INSPECTION

- a. Engineer
During construction, the INSPECTION will be the responsibility of the Department. The Department's Construction Office, shall designate those individuals responsible for inspection, and may include a number of qualified persons, including DISTRICT ELECTRICAL SUPERVISOR (DES). For signals located within a local government that SCDOT has a signal maintenance agreement, the inspection personnel may include the local government's Electrical Supervisor to perform inspection for SCDOT.
- b. Disputes
The CONTRACTOR is advised that in any dispute between the Contractor and the Manufacturer, concerning the operation/maintainability/reparability of any piece of equipment, THE DECISION OF THE ENGINEER SHALL BE FINAL.
- c. Faulty Equipment
When equipment supplied by the Department is designated faulty by the Engineer, if it is under warranty, the Contractor shall return it to the Manufacturer for replacement. The Manufacturer shall furnish a replacement unit.

8. SIGNAL INTEGRATION

The following entity will perform integration in accordance with 689.2 System Integration and Testing:

Contractor
 SCDOT – District ____
 Other _____

9. MAINTENANCE OF OPERATION

- a. Existing traffic signals shall **REMAIN IN OPERATION** until the new/modified installation has been satisfactorily tested, and it has been placed in operation after approval by the Engineer. The Testing shall be accomplished without hazard to the traveling public and while the signal heads are suitably **BAGGED WITH BURLAP**. All signal heads in place, but not in use, shall be covered with **BURLAP**. **NOTE: PLASTIC BAGS ARE NOT ACCEPTABLE.**
- b. After approval is received from the Engineer, the new signal heads shall be switched into service during that controller phase being displayed by the existing equipment; and the existing equipment shall be turned off simultaneously. Immediately after the new signal equipment has been made operational, the existing signal heads shall be turned off, and removed.
- c. The Contractor is cautioned to PLAN their work to cause minimum interference with any existing signal operation. Adjustments in the existing equipment made necessary by the new installation will be made at the expense of the Contractor.
- d. The Contractor shall retain ownership of the materials and equipment after the intersection has been made operational, until Inspection and Acceptance (either partial or final) has been made by the Engineer, when it then becomes SCDOT property. Prior to Acceptance, if the materials or equipment is damaged by whatever cause, the Contractor shall be responsible for repair or replacement.
- e. Operation, Maintenance and Emergency Service-
The contractor shall be responsible for the maintenance and operation of all existing signals in the "LIST OF PROJECT TRAFFIC SIGNALS" from the date of the "NOTICE TO PROCEED" of the contract until the final acceptance of the project. This shall include all daily maintenance of signals and any emergencies which may arise. The CONTRACTOR is also responsible and liable for proper and safe operation of each signal. Herein, this activity will be termed "Maintenance".
 - i. Restriction

The CONTRACTOR shall not change the phasing or other operation of a signalized intersection without Departmental approval.

- ii. Procedure
At that point in the project when construction activity is about to occur which could Affect the operation of a particular signal, the CONTRACTOR shall request the Department's concurrence, and the CONTRACTOR shall assume responsibility for operations and maintenance of that traffic signal. This request shall be in writing to the ENGINEER and shall have a written response. In the absence of the request, any activity of the CONTRACTOR which affects the operation of a signal shall be deemed evidence of the CONTRACTOR's assumption of responsibility for the operation and maintenance of the signal.
- iii. New Signals
Signals installed by the CONTRACTOR shall be maintained by the CONTRACTOR until the Department formally accepts the work.
- iv. Requirements
The CONTRACTOR shall perform EMERGENCY REPAIRS AND SERVICES as required, to insure continuity of operation of listed traffic signals and associated equipment. **This shall include replacement of malfunctioning LED modules.**
- v. Technician
The CONTRACTOR shall provide at least one (1) qualified LOCAL signal technician, subject to call at all times, to provide emergency services as required to assure continuous and efficient operation of signal installations and systems. This shall include non-business hours, weekends, and holidays. The Technician shall be fully qualified to trouble-shoot, service, repair and/or replace traffic controllers and components, both electro-mechanical and solid-state. At the PRE-CONSTRUCTION CONFERENCE, the CONTRACTOR shall furnish the RCE with a LIST OF THE SIGNAL TECHNICIANS who will be responsible for performing the emergency service, and the LOCAL PHONE NUMBER(S) of the CONTRACTOR's agent(s) (answering service, etc.), who will receive emergency calls during and after the CONTRACTOR's normal business hours.
- vi. Repair Time
The CONTRACTOR shall be ON-SITE of the malfunctioning signal for emergency service within the maximum time listed in the following schedule-

<u>Weekdays or Saturday</u>	<u>Maximum Time</u>
6 AM to 6 PM	1 hour
6 PM to 6 AM	4 hours
 <u>Sundays or Holidays</u>	
Day or Night	4 hours
- vii. Restoration of Normal Service
Once the CONTRACTOR has started repair work/emergency service, the CONTRACTOR shall restore a malfunctioning signal to normal phase operations uninterrupted.
- viii. Time Changes (EST/DST)
As part of Maintenance, the CONTRACTOR shall reset all time clocks to local legal time.
- ix. Records
The CONTRACTOR shall maintain a LOG of all trouble calls received, the response time, and the corrective action taken. The records and logs shall be available to Department personnel for review during normal working hours. All records and logs shall be turned over to the Department at FINAL ACCEPTANCE.
- x. Failure To Perform
In the event the CONTRACTOR fails to perform in accordance with requirements and schedules of this Specification, the Department reserves the right, without notice to the CONTRACTOR, to engage a Third Party to perform the maintenance and emergency service necessary to assure continuous traffic signal operation. Further, all expenses incurred by the Department in implementing this option, shall be deducted from the payment due the CONTRACTOR, plus a FIFTEEN HUNDRED (\$1500) DOLLAR PENALTY FOR EACH OCCASION, FOR EACH DAY (UNTIL CORRECTED). The penalty shall be forfeited as liquidated damages.

10. CONTRACT SCHEDULE

This is a "TURN-KEY" project where work is assigned using a work order system. Once work orders have been assigned to the **CONTRACTOR**, he shall furnish the Engineer with a **WEEKLY SCHEDULE** for all active traffic signal construction work orders, each Friday, for the week to come, listing the location and date of each intended activity. This will permit scheduling signal inspection personnel. Deviation from this schedule may cause the Department to delay Inspection and Payments. This contract is for a __ month period with all work to be completed within __ months of the award. There may be substitutions or additions to this list of signals, due to increased funding or change in priorities.

Or



The **CONTRACTOR** shall furnish the Engineer with a **WEEKLY SCHEDULE** for the **TRAFFIC SIGNAL CONSTRUCTION** work, each Friday, for the week to come, listing the location and date of each intended activity. This will permit scheduling signal inspection personnel. Deviation from this schedule may cause the Department to delay Inspection and Payments.

11. PAYMENT FOR MATERIALS ON HAND

This is a lump sum project, therefore no payment will be made for materials on hand.

12. SUBMITTING AS-BUILT PLANS

After the completion of the project, the **CONTRACTOR** shall furnish to the Engineer, three (3) "red-lined" sets of Plans showing the exact locations and sizes of all conduits, poles, pedestals, splice boxes, detectors, and the routing and destination of all wires leaving the control cabinets.

13. FINAL INSPECTION

a. Request

The **CONTRACTOR** shall request Final Inspection one week prior to the desired day of inspection. Confirmation to the Resident Construction Engineer shall be provided forty-eight (48) hours prior to Final Inspection, that the project is on schedule and ready for inspection.

b. System Test

Upon completion of the Final Inspection and correction of any deficiencies, the work will be subject to a **sixty (60) day operational test** for the System, and for individual intersections. If during this period a problem arises in either the System or an individual traffic signal, it must be resolved, and a **NEW sixty (60) day test** period shall begin.

14. MAINTENANCE OF TRAFFIC

The Contractor shall execute the item of Traffic Control as required by the Standard Specifications, the plans, the Standard Drawings For Road Construction, these special provisions, all supplemental specifications, the MUTCD, and the Engineer. *For Traffic Signal projects, see the amendment to the Standard Specifications, **MAINTENANCE OF TRAFFIC – General Regulations** included.*

SCDOT TRAFFIC SIGNALS

MATERIAL SPECIFICATIONS

Revised
10/1/2012

Traffic Signals Material Specifications

Table of Contents

		Revision Date
M677.1	FURNISH ELECTRICAL CABLE	10/1/2012
M677.4	FURNISH FIBER INTERCONNECT CENTER	10/1/2012
M677.5	FURNISH FIBER OPTIC MODEM	10/1/2012
M677.6	FURNISH FACTORY TERMINATED PATCH PANEL	10/1/2012
M678.1	FURNISH WIRE, SEALANT, AND/OR MATERIALS FOR DETECTOR LOOP	10/1/2012
M680.2	FURNISH SPLICE BOX/JUNCTION BOX	10/1/2012
M682.3	FURNISH STEEL CABLE	10/1/2012
M682.4	FURNISH PEDESTRIAN POLE AND BASE	10/1/2012
M686.1	FURNISH LED MODULE AND/OR POLYCARBONATE VEHICLE SIGNAL HEAD AND/OR BACKPLATE	10/1/2012
M686.3	FURNISH PEDESTRIAN SIGNAL HEADS	10/1/2012
M686.4	FURNISH PEDESTRIAN PUSH BUTTON STATION ASSEMBLY WITH SIGN	10/1/2012
M686.5	FURNISH SYMBOLIC LED BLANKOUT SIGN	10/1/2012
M688.3	FURNISH VIDEO DETECTION - LOOP EMULATION SYSTEM	10/1/2012
M688.5	FURNISH STEEL STRAIN POLE AND FOUNDATION	10/1/2012
M688.6	FURNISH CONCRETE STRAIN POLE	10/1/2012
M688.7	FURNISH CONTROLLER AND 332/336 CABINET	10/1/2012
M688.9	FURNISH SOLAR POWERED FLASHER ASSEMBLY	10/1/2012

M677.1 FURNISH ELECTRICAL CABLE

1.1 Description

This specification describes requirements for furnishing traffic signal, loop lead-in, pedestrian signal, and pedestrian push button Electrical Cable.

1.2 Materials

1.2.1 Black Cable

1.2.1.1 Traffic Signal Head Wiring

BLACK - Unless specified elsewhere, the traffic signal cable shall be four pairs (8 conductor). The conductor shall be #14 AWG, 19 strands, bare copper. The conductor insulation shall be high density polyethylene and shall be both ultraviolet and weather resistant. The wall thickness shall be 0.016 inch minimum point thickness. A polyethylene filler material shall be utilized to produce a circular cross section. The conductor cable assembly shall be wrapped with a 0.001 inch clear Mylar binder applied helically with a minimum 25% overlap. The overall cable assembly shall be provided with a high density polyethylene jacket which is both ultraviolet and weather resistant. The wall thickness shall be 0.032 inch minimum point thickness. Traffic signal cable shall be manufactured in accordance with the requirements of Underwriters' Laboratories, Federal specifications, and the National Electric Code.

The traffic signal cable must also meet or exceed specifications in the chart below.

Conductor Insulation

<i>Pair Color</i>	<i>Insulation Color</i>	<i>External Jacket Size, AWG</i>
White-Yellow Red-Green White w/Black Band-Yellow w/Black Band Red w/Black Band-Green w/Black Band	Black	#14

1.2.1.2 Pedestrian Signal Head Wiring

BLACK - Unless specified elsewhere, the pedestrian signal cable shall be two pairs (4 conductor). The conductor shall be #14 AWG, 19 strands, bare copper. The conductor insulation shall be high density polyethylene and shall be both ultraviolet and weather resistant. The wall thickness shall be 0.016 inch minimum point thickness. A polyethylene filler material shall be utilized to produce a circular cross section. The conductor cable assembly shall be wrapped with a 0.001 inch clear Mylar binder applied helically with a minimum 25% overlap. The overall cable assembly shall be provided with a high density polyethylene jacket which is both ultraviolet and weather resistant. The wall thickness shall be 0.032 inch minimum point thickness. Traffic signal cable shall be manufactured in accordance with the requirements of Underwriters' Laboratories, Federal specifications, and the National Electric Code.

The traffic signal cable must also meet or exceed specifications in the chart below.

Conductor Insulation

<i>Pair Color</i>	<i>External Jacket</i>	
	<i>Insulation Color</i>	<i>Size, AWG</i>
White-Yellow Red-Green	Black	#14

1.2.2 Gray Cable

1.2.2.1 Loop lead-in Wiring

GRAY - Unless specified elsewhere, the loop lead-in cable shall be four pairs (8 conductor). Each pair shall be individually twisted (two turns per foot minimum). Outside diameter shall be 0.60 inch maximum. The conductor shall be #14 AWG, 19 strands, bare copper. The conductor insulation shall be high density polyethylene and shall be both ultraviolet and weather resistant. The wall thickness shall be 0.016 inch minimum point thickness. Each pair shall be wrapped with a 0.001 inch aluminum shield with a minimum 25% overlap. Aluminum is to be located on the outside. A polyethylene filler material shall be utilized to produce a circular cross section. The drain wire shall be #16 AWG, 19 strands, tinned copper. The conductor cable assembly shall be wrapped with a 0.001 inch clear Mylar binder applied helically with a minimum 25% overlap. The overall cable assembly shall be provided with a high density polyethylene jacket which is both ultraviolet and weather resistant. The wall thickness shall be 0.032 inch minimum point thickness. Traffic signal cable shall be manufactured in accordance with the requirements of Underwriters' Laboratories, Federal specifications, and the National Electric Code.

The twisted pair loop lead-in cable must also meet or exceed specifications in the chart below.

Conductor Insulation

<i>Pair Color</i>	<i>External Jacket</i>	
	<i>Insulation Color</i>	<i>Size, AWG</i>
White-Yellow Red-Green White w/Black Band-Yellow w/Black Band Red w/Black Band-Green w/Black Band	Gray	#14

1.2.2.2 Pedestrian Push Button Wiring

GRAY - Unless specified elsewhere, the pedestrian push button cable and loop lead-in to each pole shall be two pairs (4 conductor). Outside diameter shall be 0.38 inch maximum. The conductor shall be #14 AWG, 19 strands, bare copper. The conductor insulation shall be high density polyethylene and shall be both ultraviolet and weather resistant. The wall thickness shall be 0.016 inch minimum point thickness. Each pair shall be wrapped with a 0.001 inch aluminum shield with a minimum 25% overlap. Aluminum is to be located on the outside. A polyethylene filler material shall be utilized to produce a circular cross section. The drain wire shall be #1 AWG, 19 strands, tinned copper. The conductor cable assembly shall be wrapped with a 0.001 inch clear Mylar binder applied helically with a minimum 25% overlap. The overall cable assembly shall be provided with a high density polyethylene jacket which is both ultraviolet and weather resistant. The wall thickness shall be 0.032 inch minimum point thickness. Traffic signal cable shall be manufactured in accordance with the requirements of Underwriters' Laboratories, Federal specifications, and the National Electric Code.

The traffic signal cable must also meet or exceed specifications in the chart below.

Conductor Insulation

<i>Pair Color</i>	<i>Insulation Color</i>	<i>External Jacket Size, AWG</i>
White-Yellow Red-Green	Gray	#14

1.2.3 Certification

CATALOG CUTS ARE REQUIRED

1.2.4 Warranty

The Vendor shall furnish SCDOT with any warranties on equipment and materials that are provided by the Manufacturer or Vendor as normal trade practice.

1.2.5 Labeling and Delivery

Unless otherwise stated, the cable shall be supplied in minimum reels of 1,000 feet, for splice-free installation.

The Manufacturer shall be required to mark each cable and cable reel to facilitate easy identification of the various sizes when stored in stockpiles.

1.3 Measurement

Electrical Cable, of the size and numbers of conductors specified, shall be measured by LINEAR FEET and furnished in 1000' reels.

1.4 Payment

Furnishing Electrical Cable, measured as provided above, will be paid at the contract unit price bid for:

FURNISH NO. 14 COPPER WIRE, 4 CONDUCTOR - BLACK	1000' REEL
FURNISH NO. 14 COPPER WIRE, 4 CONDUCTOR - GRAY	1000' REEL
FURNISH NO. 14 COPPER WIRE, 8 CONDUCTOR - BLACK	1000' REEL
FURNISH NO. 14 COPPER WIRE, 8 CONDUCTOR - GRAY	1000' REEL

M677.4 FIBER INTERCONNECT CENTER

1.1 Description

This specification describes requirements for furnishing a Fiber Interconnect Center.

1.2 Materials

1.2.1 Interconnect Center

The CONTRACTOR shall furnish and install rack-mounted Fiber Optic Interconnect Centers into the new and reused type-170 cabinets at the locations shown on the PLANS. The Fiber Interconnect Center shall include ST adapter panel, strain relief hardware, be rack mountable, have the capacity for 4 Fusion Splice Trays and termination/connection capacity for 24 fibers in 4 modules. The Center shall be a Systimax 600G2-1U-UP-SD or approved equivalent.

The interconnect center shall be equipped with 2 fiber optic modular connector panels with 24 factory-installed interconnection sleeves. The modular interconnection panels shall be clearly labeled (transmit/receive). The interconnection sleeves shall be types ST compatible, with ceramic insert, and composite housing for single-mode fiber optic cable. These shall be Systimax MODG2-6ST-SM-PT-A and MODG2-6ST-SM-PT-B or approved equivalent.

Each interconnect center shall be furnished with 3 Fusion Splice Trays. The trays shall be capable of accepting 12 fusion and 6 mechanical splices. The tray shall be a Systimax RS-2AF-16SS or approved equivalent.

1.2.2 Certification

CATALOG CUTS ARE REQUIRED

1.2.3 Warranty

The Vendor shall furnish SCDOT with any warranties on equipment and materials that are provided by the Manufacturer or Vendor as normal trade practice.

1.3 Measurement

Furnishing a Fiber Optic Interconnect Center will be measured by EACH.

1.4 Payment

The fiber interconnect center, as measured above, will be paid for at the contract unit price bid for:

FURNISH FIBER OPTIC INTERCONNECT CENTER	EACH
---	------

M677.5 FURNISH FIBER OPTIC MODEM

1.1 Description

This specification describes requirements for furnishing a Fiber Optic Modem as shown on the plans or as established by the ENGINEER, in accordance with these specifications.

1.2 Materials

1.2.1 General

The Optical Transceiver shall electrically interface with an Electronic Industries Association (EIA) RS-232 C/D compatible computer equipment communications port and convert the signals to an optical, intensity modulated form supporting communications over single-mode, optical fiber at a 1300 nanometer (nm) nominal wavelength. Electrically transmitted signals shall be converted to optically modulated signals. Optically modulated signals received by the optical transceiver shall be demodulated and converted to electrical signals for transfer to the attached computer or controller device via the electrical RS-232 interconnection.

The Optical Transceiver (OTR) to support multi-dropped communications must include an optical repeating capability. Thus, the device is designated OTR-Repeating or "OTR/RP". The OTR/RP shall receive an uplink signal and shall not only drop the signal as electrical to the attached computer or controller but it shall also repeat the signal to the attached, downlink device. The attached computer will be programmed to respond to its address, thus providing multi-dropped link management. The OTR/RP shall repeat both uplink received signals and downlink received signals to provide communications continuity. Both uplink received and downlink received signals shall be demodulated, converted to RS-232 compatible electrical signals and transferred to the attached controller via the RS-232 interface.

In summary, the OTR/RP must:

- a) Bi-directionally communicate with compatible up and downlink OTR(s).
- b) Repeat uplink received signals to the downlink connected OTR.
- c) Demodulate any received optical signal and provide the signal in electrical form to an attached controller via an RS-232 connection. Convert an electronically received signal from an attached controller via the RS-232 connection and optically transmit the signal to any uplink and downlink attached OTR(s).

The OTR/RP shall be compatible with non multi-dropped OTR(s) which support multi-dropped link origination and termination. The OTR/RP shall apply to multi-drop connected controllers which require optical repeating capability.

1.2.2 Electrical Interface

The OTR/RP shall receive 24 VAC power from a step down transformer supplied with the unit. The OTR/RP shall require no more than 350 ma peak load current, which shall be supplied by a 500 ma or greater step down transformer. The transformer shall receive 110 VAC + 15%, 60 Hz + 10% prime power from a utility power strip within a controller cabinet. A three (3) prong, standard power connector shall be provided with the transfer. The 24 VAC power cable from the transformer to the OTR/RP shall be a minimum of six (6) feet and terminated with a compatible female connector or with leads prepared for

easy attachment to a terminal block on the OTR. A DB-9 power connector is preferred; however, a terminal block is acceptable.

OTR/RP circuitry shall be designed to operate with 24 VAC voltage fluctuations of +15%. Where over or under voltage conditions exist out of the operating range of the OTR/RP, circuitry shall protect the OTR/RP electronics from damage. The OTR/RP shall automatically recover from an over or under voltage condition when the input power returns to the normal operating range.

The OTR/RP shall be interconnected to a computerized controller through an RS-232 C/D interface channel. A DB-25S connector shall be provided to accommodate the electrical communications interface. EIA RS-232 interconnect standards as presented in Table 3.1.2-1 shall be accommodated as applicable. The "request to send" and "clear to send" signals shall be utilized to control transmission. Full duplex asynchronous data transmission shall be accommodated by the design.

Signal ground shall be accommodated on Pin 7 of the DB-25S connector. Chassis ground shall be accommodated on Pin 1 of the DB-25 connector and Pin 1 of the DB-9 connector. There shall be no internal connection between signal ground and chassis ground. For any metallic cable interconnection with the OTR/RP design, a means of protecting electronics from lightning shall be included

The RS-232 electrical interface shall be capable of operating at data rates of 1200, 2400, 4800, 9600, 19.2 kB, 38.4 kbps, up to a minimum of 50 kbps.

1.2.3 Optical Interface

The optical interface to the OTR/RP shall be single-mode fiber, 8.3 +0.5 microns, via FCPC connectors. Mode fields of either depressed cladding or matched cladding shall be accommodated by the connector in accordance with the following:

- a) Depressed Clad Mode Field = 8.8+0.5 micron
- b) Matched Clad Mode Field = 10.5+1 micron

Female connectors shall be provided on the OTR/RP device as follows:

- a) Transmit uplink
- b) Transmit downlink
- c) Receive uplink
- d) Receive downlink

Table 3.1.2-1
Optical Transceiver Interconnect

				EIA RS-232 C RS-232 D	
	Description	Abbr.	Direction of Signal to	Circuit	25 Pin
GROUND	Protective Ground (Shield)			AA	1
	Signal Ground (Common return)	SG		AB	7
	DTE Common return				N/A
	DCE Common return				N/A
DATA	Transmitted Data	TD	DCE	BA	2
	Received Data	RD	DTE	BB	3

CONTROL	Request to Send	RTS	DCE	CA	4
	Clear to Send	CTS	DTE	CB	5
	Data Set Ready	DSR	DTE	CC	6
	Data Terminal Ready	DTR	DCE	CD	20
	Data Carrier Detect	DCD	DTE	CF	8
	Ring Indicator	RI	DTE	CE	N/A
TIMING	Transmit Clock (from DTE)	TTC	DCE	DA	N/A
	Transmit Clock (from DCE)	TC	DTE	DB	N/A
	Receive Clock (from DCE)	RC	DTE	DD	N/A
TESTS	Remote Digital Loopback V.54/2	RLB	DCE	RL	N/A
	Local Analog Loopback V.54/3	LLB	DCE	LL	N/A
	Test Mode	TM	DTE	TM	25
	SOURCES		EIA RS-232		ISO 2110

Notes:

1. DB-25S Connector
2. Wire per International Systems Organization (ISO) Standard 2110 as indicated.
3. N/A = Not Applicable to the OTR/RP
4. Signals may be interconnected as required by the OTR/RP to accomplish communications.

A minimum of four (4) fiber optic FCPC interconnections shall be provided. The fiber optics transmitter and fiber optics receiver devices shall operate at 1300 nm, nominal. Transmitter launch power shall be a minimum of -15 dBm. The optical receiver shall be capable of receiving a -30 dBm signal providing a bit error rate not exceeding 1 error in 10⁹ bits. When a fiber optics transmitter and receiver are interconnected via a single-mode fiber, a link loss of 15 dB minimum shall be accommodated to 100% confidence level, while providing communications in conformance with this specification.

The OTR/RP circuitry shall be capable of receiving electrical digital data up to 50 kbps and converting the electrical bit stream to an intensity-modulated optical signal launched at a minimum of -15 dBm (minimum) in both the upstream and downstream directions (i.e., via both transmit fibers). Similarly, the OPR/RP circuitry shall have the capability of receiving an intensity-modulated optical signal at modulation rates of 50 kbps or less, at a minimum signal level of -30 dBm and;

- a. Demodulate the optical signal and convert the signal to an equivalent electrical signal at the RS-232 receive data interface; and
- b. Repeat the optical signal at a launch power of at least -15 dBm via the optical transmitter opposite the receive side (i.e. if received upstream then transmit downstream; if received downstream then repeat upstream) with delays not to exceed 1 microsecond.

The data rate of the OTR/RP link shall be automatically adaptable to the attached RS-232 electrical signal interface to a minimum of 50 kbps. Typical data rates to be utilized on the communications links are 1200, 2400, 4800, 9600, 19.2 and 38.4 kbps.

The optical repeating process shall not add signal distortion nor optical noise which would comprise the link performance to achieve a 10⁻⁹ bit error rate. To assure stability of the optical transmitter over environmental temperature range, the optical transmitter shall be a solid state laser diode; edge emitting transmitter devices shall not be utilized.

The master controller may be interconnected with an RS-232 OTR which is interconnected with an RS-232 OTR which is non-repeating, designated "OTR". The OTR/RP(s) provided shall be optically

compatible with OTR(s) provided. Similarly, the electrical RS-232 interface shall also be compatible between any other OTR/RP(s) and OTR(s) provided. An OTR/RP shall be usable as a master controller interface to control the multi-dropped communications link with any upstream-terminated communications port.

1.2.4 Communication Performance

All OTR/RP(s) shall have compatible communications specifications. When two (2) or more OTR/RP(s) are interconnected by a single-mode fiber optic cable conforming to the following specifications:

Type:	Single-Mode
Core Diameter:	8.3 +0.5 micron
Mode Field:	
Depressed Clad	8.8 +0.5 micron
Matched Clad	10.5 +1 micron
Concentricity:	<1.0 micron
Cladding Diameter:	125.0 +2 microns
Coating Diameter:	250.0 +15 microns
Operating Wavelength:	1300 nm
Link loss does not exceed:	17 dB

And, link loss budget between any two (2) OTR/RP(s) shall not exceed 15 dB when the two (2) communications devices:

- a) Are operated within the environmental specifications stated herein;
- b) Are operated within the power input variations specified herein;
- c) Are electrically compliant with the RS-232 and data rate specifications stated herein; and
- d) Are operated with error-free input data,

Then, the receiving OTR/RP(s) shall provide electrical interface to all attached controllers with a bit error of no greater than 1 in 10⁹ bits.

The OTR/RP shall be provided with an anti-streaming function which will inhibit the connected controller from transmitting if a selected transmit time is exceeded. Maximum transit time shall be selectable in binary increments of 4, 8, 16, 32, 64 or infinity (i.e. anti-streaming disabled) seconds. A dip switch shall select the anti-streaming time out. Factory setting of the anti-streaming time setting shall be 16 seconds. Should the maximum selected transmission time be exceeded, the anti-streaming logic shall detect a data transmission from the RS-232 port, inhibit the "Clear to Send" control signal, and block the transmission port. Once the anti-streaming logic has been activated, the "Clear to Send" control signal shall be inhibited and the transmitted data port blocked until a manual reset button located on the OTR/RP is depressed by maintenance personnel. Activation of the anti-streaming function shall not impact the repeating function of the OTR/RP.

1.2.5 Quality Assurance

Each OTR/RP device shall be successfully pre-tested to a formal factory functional test procedure. Each OTR/RP shall have been tested for a time period and with appropriate environmental stress screening to eliminate infant mortality of electronic components and marginal mechanical connections of electrical devices supporting the required product reliability. Products which have not been previously field tested in a similar environment are unacceptable. The OTR/RP devices shall be manufactured and tested under Quality Assurance procedures as recommended by BELLCORE, Electronic Industries Association or compliant with International Standards Organization, ISO-9000 Quality Assurance Specification.

The OTR/RP shall have a Mean Time between Communication Failure of 43,800 hours when operated as a pair, to a 95% confidence level. The OTR/RP shall comply with FCC Class A requirements.

The following specifications apply to the OTR/RP to the extent specified herein. Where a conflict exists between referenced specifications and this specification, this specification shall have precedence. Unless otherwise noted, the latest issues of specifications shall apply.

Electronic Industries Association (EIA)

Specification Number	Title or Subject	Applicability
RS-232 C/D	Serial Data Transmission, Physical, Functional and Electric Specifications	OTR/RP shall accommodate interfaces

Institute of Electrical and Electronic Engineers

Specification Number	Title or Subject	Applicability
C2-1994	National Electrical Safety Code	Compliance as applicable to electronic communications devices for construction,
C62.36-1991	Test Methods for Surge Protectors Used in Low Voltage Data, Communications and Signaling Circuits	General Guideline
C62.41-1991	Recommended Practice on Surge Voltage Protection in Low Voltage AC Circuits	General Guideline
295-1969	Standard for Electronics Power Transformers	As applicable to power converter
1100-1992	Recommended Practice for Powering and Grounding Sensitive Electronics Equipment	General Guideline

Federal Communications Commission (FCC)

Standard	Title or Subject	Applicability
FCC Rules and Regulations for Class A Electronic Equipment; Vol. II, Part 18	Radio Frequency Interference and Electromagnetic Compatibility	As applicable to equipment class
FCC/OST, MP-4	FCC Methods of Measuring Radio Noise Emissions from Computing Devices	General Guideline

Other Specifications

Organization Standard	Title or Subject	Applicability
International Standards Organization (ISO) ISO-9000	Quality Assurance	ISO-9000 or Bellcore TR-NWT-000874 applies. Intent is for product to be produced under a

		formal Quality Assurance Program.
Bellcore TR-NWT-000874	Reliability and Quality General Requirements	ISO-9000 or this specification applies.

1.2.6 Warranty

The Vendor shall furnish SCDOT a 5 year warranty from purchase date on equipment and materials that are provided by the Manufacturer or Vendor as normal trade practice. During the period of **24 months** following the date of ACCEPTANCE, the Manufacturer or Vendor shall replace, at no expense to the Department (including shipping costs), any portion of the equipment or material that fails by reason of defective material or workmanship.

Replacement shall be provided within 30 days of receipt of failed equipment at no cost to the State.

1.3 Measurement

Furnishing a Fiber Optic Modem will be measured by EACH and will include a power supply and RS-232 cable.

1.4 Payment

Fiber Optic Modem, accepted and measured as stated herein, shall be paid for at the contract unit price bid for:

FURNISH FIBER OPTIC MODEM	EA
---------------------------	----

M677.6 FURNISH FACTORY TERMINATED PATCH PANEL

1.1 Description

This specification describes requirements for furnishing a Factory Terminated Patch Panel. Included in this item is the splicing of the fiber optic cable; installing interconnection sleeves, jumpers, connectors and other hardware that may be needed for connecting the fiber optic cable to the signal system electronic devices.

1.2 Materials

1.2.1 Factory Terminated Patch Panel

The interconnect center shall be a factory terminated patch panel, including strain relief hardware and have termination/connection capacity for 12 fibers and a 200' tail.

1.2.2 Certification

CATALOG CUTS ARE REQUIRED

1.2.3 Warranty

The Vendor shall furnish SCDOT with any warranties on equipment and materials that are provided by the Manufacturer or Vendor as normal trade practice.

1.3 Measurement

Furnishing a Factory Terminated Patch Panel will be measured by EACH.

1.4 Payment

The Factory Terminated Patch Panel, as measured above, will be paid for at the contract unit price bid for:

FURNISH FACTORY TERMINATED PATCH PANEL	EA
--	----

M678.1 FURNISH WIRE, SEALANT, AND/OR MATERIALS FOR DETECTOR LOOP

1.1 Description

This specification describes requirements for furnishing Wire, Sealant, and/or Materials for a Detector Loop.

1.2 Materials

1.2.1 Loop Wire

Loop wire shall be splice-free lengths of: No. 14 AWG, 19 Strands, single-conductor bare copper wire. The conductor insulation (BLACK or GRAY) shall be high density polyethylene and shall be both ultraviolet and weather resistant. The wall thickness shall be 0.030 inch minimum point thickness. Cable shall be manufacturer in accordance with the requirements of Underwriters Laboratories, Federal specifications, and the National Electric Code.

1.2.2 Sealant

The loop sealant used to fill the saw cuts and other gaps, shall be of a type intended for traffic loop embedding. The cured sealant shall be semi-flexible, and be capable of adhering securely to concrete, asphalt, wood, metal, etc. It shall be unaffected by freeze-thaw cycling, salts, gasoline, oil, sewerage and corrosive chemicals. It shall be proportioned and mixed per the manufacturer's specifications. Acceptable sealants are listed on the SCDOT QPL.

1.2.3 Waterproofing Splice Materials

The splice at the "junction point" shall be made waterproof using the materials listed below:

- a) Cable Splice Kit - Commercially available, Low-Voltage, water-proof Splice-kit; to be Plymouth "PLYFLEX"; or 3M "SCOTCH-LOK", Unipak #3570, Resin 400, (or approved equal). To be installed per manufacturer's instructions.
- b) Heat Shrink tubes
- c) Gel Caps
- d) Vinyl plastic electrical tape (use where required)-Cold and weather resistant, 19 mm (3/4 inch) wide, 1.8 mm (7 mil) thickness, (Scotch 33+ or approved equal). Shall use liquid electrical coating (where required) - Fast-drying sealant compatible with vinyl tape, brush-applied (3M, Scotchkote or approved equal).

1.2.4 Underwater Splicing Kit

Where shown on the Plans, in very wet areas an Underwater Splice Kit may be required at the "junction point". This splicing kit shall consist of a two-piece mold-body, with pourable resin sealing compound, funnels, and end sealing strips (3M, Scotchcast 82-A1 or approved equal).

1.2.5 Wire Crimps

The PREFERRED splicing method at the "junction point", shall use a commercial/industrial grade, copper-alloy CRIMP-ON, with one end closed, of a size proper for the gauge of wires to be spliced, and

the number of conductors. It shall be installed with butt splice using a T & B type crimping tool or similar tool, intended for the purpose (NOT regular pliers). (Note: wire-nuts are not acceptable.)

1.2.6 Solder

The alternate method of splicing at the "junction point" is to use SOLDER, which shall be electronic-grade, rosin-core, 60 lead/40 tin. Acid-core solder is not acceptable, nor are acid-type soldering pastes.

1.2.7 Certification

The Vendor shall provide details for the loop sealant, loop wire, and lead-in wire proposed.

CATALOG CUTS ARE REQUIRED

SAMPLE REQUIRED

1.2.8 Warranty

The Vendor shall furnish SCDOT with any warranties on equipment and materials that are provided by the Manufacturer or Vendor as normal trade practice.

1.3 Measurement

Wire for Detector Loops, of the size and numbers of conductors specified, shall be measured by LINEAR FEET and furnished in 5000' reels.

1.4 Payment

Furnishing Wire for Detector Loops, measured as provided above, will be paid at the contract unit price bid for:

FURNISH NO. 14 COPPER WIRE, 1-CONDUCTOR FOR LOOP WIRE	5000' REEL
---	------------

M680.2 FURNISH SPLICE BOX / JUNCTION BOX

1.1 Description

This specification describes requirements for furnishing a Splice Box and/or Junction Box. The Splice Box shall consist of a Box and Cover, installed over aggregate. The Splice Box is intended for use as a signal cable electrical enclosure. The Junction Box is intended for use as a loop detector "junction point".

1.2 Materials

1.2.1 Box and Cover

The Splice Box shall consist of a Base having an open top (the Box), with a separate removable Cover. They shall be made from a lightweight, blended modern material, using fiberglass reinforcement, and shall be NON-CONCRETE / NON-STEEL. They shall be GRAY IN COLOR. Covers shall have the LEGEND "TRAFFIC SIGNAL". They shall use HEX-HEAD stainless steel bolts. The PHYSICAL FEATURES AND THE NOMINAL SIZE AND DIMENSIONS for the Box and Cover, are shown on the Standards or the Design Details, and are listed below.

	<u>WIDTH</u>	<u>LENGTH</u>	<u>DEPTH</u>
SPLICE BOX:	13 inch	24 inch	18 inch
HAND BOX:	17 inch	30 inch	24 inch
MINI SPLICE BOX:	12 inch	12 inch	12 inch

1.2.2 Design Load

Boxes shall be designed to meet or exceed the loading requirements for a Tier 15 application per the Society of Cable Engineers (SCTE) ANSI/SCTE 77-2007 "Specification for Underground Enclosure Integrity, Table – Test Loads".

Thus, boxes shall be designed and tested for the following test loads: Cover- vertical load 22,500 pounds distributed over a 10 inch x 10 inch area. Box - vertical load 22,500 pounds distributed over a 5 inch x 10 inch. Box- lateral load of 1200 pounds per square foot . The cover deflection shall be less than 0.5 inch; and the box deflection less than 0.25 in/ft of length.

1.2.3 Western Underground Committee (WUC)

Using the above specified loads, the Splice Box shall meet or exceed the WUC "Recommended Guide No. 3.6, Non-Concrete Enclosures". Structural Requirements shall include: testing for Vertical Load on Cover; Vertical Load on Box; Lateral Load on Box. Further they shall meet WUC recommendations for: Accelerated Service per ASTM D-756; Chemical Resistance per ASTM D-543; Simulated Sunlight Resistance per ASTM G-53; plus Water Absorption; and Flammability. Covers shall be skid-resistant, with a minimum coefficient of friction of 0.50.

1.2.4 Certification

CATALOG CUTS ARE REQUIRED

1.2.5 Warranty

The Vendor shall furnish SCDOT with any warranties on equipment and materials that are provided by the Manufacturer or Vendor as normal trade practice.

1.3 Measurement

Furnishing a Splice Box will be measured by EACH Box including Box and Cover.

Furnishing a Junction Box will be measured incidental to the conduit to which it is used with.

1.4 Payment

Furnishing Splice Box and/or Junction Box, accepted and measured as provided above, will be paid for at the contract unit price bid for:

FURNISH 13"X24"X18"D.ELEC.FLUSH UNDGRD.ENCLOSURE-(STR.POLY.CONC.)HD	EA
FURNISH 17"X30"X24"D.ELEC.FLUSH UNDGRD.ENCLOSURE-(STR.POLY.CONC.)HD	EA
FURNISH 12"X12"X12"D.ELEC.FLUSH UNDGRD.ENCLOSURE-(STR.POLY.CONC.)HD	EA

M682.3 FURNISH STEEL CABLE

1.1 Description

This specification describes requirements for furnishing splice-free lengths of Steel Cable with cable supports, for mounting signal heads, signs, interconnect runs, and installing back guys.

1.2 Materials

1.2.1 Fabrication

Steel Cable shall be fabricated of 7 steel wires, Class A double galvanized in accordance with ASTM A-475, and twisted into a single concentric strand to conform with the following schedule:

Diameter (inches)	Strand Size (AWG)	Tensile Strength (pounds)
1/4	14	3,150
3/8	11	6,950
7/16	9.5	9,350
1/2	8	12,000

Usage

Span Wire - All Steel Cable used as span wire shall be 3/8 inch in diameter, unless otherwise noted on the Plans.

Messenger Wire - All Steel Cable used as messenger shall be 1/4 inch in diameter, unless otherwise noted on the Plans.

Tether Wire - All Steel Cable used as tether wire shall be 1/4 inch in diameter, unless otherwise noted on the Plans.

Back Guy - All Steel Cable used for back guying shall be 3/8 inch in diameter, unless noted otherwise on the Plans.

Cable Supports

Aluminum Tie-wrap - Shall be Flat Aluminum Armor Tape, 0.05 inch Thick X 0.30 inch Wide, typically furnished in 10 pound coils.

Where specifically required, Support Rings (also called "cable rings", "messenger rings") shall be galvanized in accordance with ASTM A-153, and the design approved by the ENGINEER, and shall be 2 to 3 inches in diameter (to contain the Electrical Cables), and sized to specifically match the Steel Cable.

Miscellaneous Hardware

All hardware and fittings shall be of the type shown on the Standards or the Construction and Installations Details.

All hardware and fittings shall be made of galvanized steel or non-corrosive metal. The tensile strength of all hardware shall be equal-to or greater-than the Steel Cable installed.

All thimble-eye and oval eye-bolts used to connect the automatic compression dead-end clamps to wooden poles, shall be 3/4 inch diameter. S-hooks shall be the same diameter as the cable. Fiberglass insulators shall be fabricated from epoxy-resin impregnated fiberglass strands, and have a tensile strength 50% greater than the Steel Cable.

Certification

The Vendor shall provide a Certification from the Manufacturer that the Steel Cable has been tested to meet or exceed the required tensile strength.

Warranty

The Vendor shall furnish SCDOT with any warranties on equipment and materials that are provided by the Manufacturer or Vendor as normal trade practice.

1.3 Measurement

Steel Cable of the SIZE specified shall be measured by the LINEAR FEET and furnished in 1000' reels.

1.4 Payment

Accepted quantities of Steel Cable, measured as stated above will be paid for at the contract unit price bid for:

FURNISH 3/8" GALVANIZED STEEL CABLE	1000' REEL
FURNISH 1/4" GALVANIZED STEEL CABLE	1000' REEL

M682.4 FURNISH PEDESTRIAN POLE AND BASE

1.1 Description

This specification describes requirements for furnishing a Pedestrian Pedestal Pole and Base.

1.2 Materials

1.2.1 Aluminum Base

Pedestrian bases shall be constructed of aluminum. The neck of the base shall be threaded to accommodate a 4 inch diameter aluminum pole. The neck will also house a set screw that prevents counter rotation.

1.2.2 Anchor Bolts

Four (4) Anchor Bolts shall be supplied with each base. Each Anchor Bolt shall be threaded at the top, and shall have an L-bend at the bottom. A total of eight nuts and eight flat washers shall be supplied. Nuts shall be ASTM 563 Grade A.

1.2.3 Aluminum Pole

Aluminum pedestrian pole shall be 4 inches in diameter and 4 feet, 8 feet and/or 10 feet in length. It shall be constructed of polished aluminum and threaded on one end.

1.2.4 Warranty

The Vendor shall furnish SCDOT with any warranties on equipment and materials that are provided by the Manufacturer or Vendor as normal trade practice.

1.3 Measurement

Furnishing a Pedestrian Pedestal Pole and Base will be measured by EACH including all required incidental hardware.

1.4 Payment

Furnishing a Pedestrian Pole and Base measured as provided above, will be paid for at the contract unit price for:

FURNISH 4' BREAK-AWAY ALUMINUM PEDESTAL POLE AND BASE	EA
FURNISH 8' BREAK-AWAY ALUMINUM PEDESTAL POLE AND BASE	EA
FURNISH 10' BREAK-AWAY ALUMINUM PEDESTAL POLE AND BASE	EA

M686.1 FURNISH LED MODULES AND/OR POLYCARBONATE VEHICLE SIGNAL HEADS AND/OR BACKPLATES

1.1 Description

This specification describes requirements for furnishing LED Modules and/or Polycarbonate Vehicle Signal Heads and/or Backplates of the types, sizes, and mounting specified, in accordance with these Specifications. The signal modules shall maintain the pixilated appearance typical with earlier generations of LED's modules. Signal LED modules shall be designed to go dark after 40% of the LED's fail. The red section in the five section head shall be aluminum. All Signal Heads shall be supplied with the appropriate LED Modules installed and operational.

1.2 Materials

1.2.1 Signal Heads

All Signal Heads shall conform to the July 1998 Interim Purchase Specifications of the ITE VTCSH part 2 (Light Emitting Diode (LED) Vehicular Traffic Signal Modules (hereafter referred to as VTCSH-2) published by the INSTITUTE OF TRANSPORTATION ENGINEERS (ITE), "Standard for Adjustable Face Vehicular Traffic Control Signal Heads" (latest Revision). All heads shall be furnished by the SAME MANUFACTURER as well as each module in the head. Polycarbonate Vehicle Signal Heads of the size, type, and arrangement specified, are to be furnished by the Manufacturer or Vendor, together with ALL the necessary hardware for make-up and mounting. The basic material requirements are listed below:

1.2.1.1 Housing

The COLOR shall be Federal YELLOW.

Each Signal Head housing shall consist of an assembly of separate interchangeable sections, each holding an individual optical unit, and stainless steel parts between the signal heads, including the tri-std coupling washer and bolts. THE TOP SECTION OF EACH 3-SECTION HEAD SHALL HAVE AN ALUMINUM REINFORCING / BEARING PLATE INSIDE THE HEAD. The Aluminum reinforcing / bearing plate retaining screws shall provide for a watertight seal to prevent water from entering the housing. The TOP SECTION OF THE FIVE-SECTION CLUSTER, AND OF THE FOUR-SECTION IN-LINE, SHALL BE ALUMINUM. The Aluminum section shall be Federal Yellow and shall be fade resistant for a minimum of five years. The rest of those configurations shall be POLYCARBONATE.

The material of the Housing, Door, and Visor shall be engineering-grade structural, ultraviolet-stabilized PURE POLYCARBONATE resin. Other plastics are NOT acceptable. All edges shall be milled to a uniform round edge and free of all sharp edges.

1.2.1.2 Polycarbonate

The Department is aware of the design characteristics of this material--particularly the fact that as fillers are added for strength, the material becomes more brittle. We also recognize that signal manufacturers have optimized their designs around a specific formulation. There is also a requirement for an un-filled polycarbonate lens material that is strong, but will not darken (burn) or color fade. Therefore the VENDOR shall provide complete particulars about the polycarbonate type number proposed, for both the HOUSING and for the LENSES. Further the VENDOR shall submit strength and wind tunnel test results (See Paragraph 1.2.5 Certification)

1.2.1.3 Door

The COLOR shall be Federal YELLOW.

The door latches shall consist of stainless steel latch eye-bolts, wing-nut, and washer; all retained to keep them from falling to the street. No special tools shall be necessary to unlatch and open a door. Doors shall be easily removed; hinge-pin shall not have to be taken out to remove door.

The hinges, shall be reinforced protrusions (mortise and tenon) from the door, with a minimum of one stainless-steel pins.

1.2.1.4 Visor

The Visor COLOR shall be Federal YELLOW outside, and dull BLACK inside.

The Visor CLASSIFICATION shall be TUNNEL (slot at bottom), unless otherwise specified.

The Visor shall be twist-on, attached to the housing with four stainless steel SCREWS, through the twist-on tabs on the visor.

1.2.1.5 Wiring

Wiring and Electrical shall be in accordance with ITE Standards. Color Coded wiring shall be factory connected to a barrier type TERMINAL BLOCK in the LOWER PORTION OF THE RED SECTION of each Signal Head. In the five-section cluster, the TERMINAL BLOCK shall be located in the (TOP) SECTION.

The TERMINAL BLOCK shall be double sided barrier type with two screws per barrier section; and shall make connections to the lamp wires using fast-on SPRING-LOADED SPADE LUGS and screws, (i.e. provisions should be made so that spade lugs or screws can be used on the same terminal block.) ONE PER SCREW. The terminal attachment sections and screws shall be stainless steel. More than one neutral is allowed per terminal. The number of barrier sections in the TERMINAL BLOCK for the three and four section head, shall be 6-position, 12-terminal. For the five section head, it shall be 8-position, 16-terminal.

1.2.1.6 Mounting Assemblies

All mounting hardware shall be furnished for Span-Wire mounting, as requested by the purchase order. Hardware for Span-Wire shall be finished Federal YELLOW

For Span-Wire mounting, the HANGER shall be cast ALUMINUM, and shall contain two stainless steel J-Hooks with stainless steel lock washers and nuts, and have seven notches to position the hanging signal. A double weatherhead entrance shall be used. The weatherhead entrance BUSHING shall have a 1-1/2 inch hole for wire entry. That entrance diameter shall be maintained throughout the weatherhead, without restriction or reducing the hole diameter, into the signal head. No special tools shall be required to tighten or adjust signal heads. Span wire hangers shall not require disassembly to install on span wire.

For Span-Wire mounting, for MULTI-WAY heads, there shall be included a "SWIVEL BALANCE ADJUSTER" for proper vertical alignment.

For 5-SECTION CLUSTER signal assemblies, ONE Span-Wire Hanger shall be furnished, attached to the top signal section. The configuration shall be FHWA MUTCD TYPE 'S', known as the "dog-house head". At the bottom of the top signal section, a cast-aluminum bracket shall connect with the

arrow side, and with the ball indication side. This bracket shall have a removable, threaded "knockout" plug at each 90-degree turn, to facilitate wiring.

A 2 inch wide ribbed, cast aluminum BOTTOM BRACKET (No. 10 018 or equiv.), having holes 17 inches on-center, shall be used to unify the assembly. (The two sides of the cluster shall be not more than 8 inches apart.)

For 4-SECTION "T" ASSEMBLY, ONE Span-Wire Hanger shall be furnished, together with two cast aluminum brackets. The two red sections shall be not more than 8 inches apart.

1.2.1.7 Balance Adjuster

When needed, a Balance adjuster shall be aluminum with a 3/4" WEH. It shall be furnished Federal Yellow and shall have stainless steel bushing, stainless steel hardware, and a stainless steel eye. This item, as part of the furnish contract, shall not come attached to the signal head assemblies.

1.2.2 **LED Modules**

Provide modules that consist of an assembly that utilizes LEDs as the light source in lieu of an incandescent lamp for use in traffic signal sections. Use LEDs that are AlInGaP technology for red and yellow indications and InGaN for green indications. Install the ultra bright type LEDs that are rated for 100,000 hours of continuous operation from -40°C to +74°C. Design modules to have a minimum useful life of 60 months, and to meet all parameters of this specification during this period of useful life.

Ensure, unless otherwise stated in these specifications, that each module meets or exceeds the requirements of the Interim Purchase Specification of the ITE VTCSH part 2 (Light Emitting Diode (LED) Vehicular Traffic Signal Modules (hereafter referred to as VTCSH-2). Arrow displays shall meet or exceed the electrical and environmental operating requirements of VTCSH-2 sections 3 and 5, chromaticity requirements of section 4.2, and the requirements of sections 6.3 (except 6.3.2) and 6.4 (except 6.4.2).

Each LED module supplied shall be factory installed in vehicle signal head or shipped as a complete kit designed for retrofitting existing traffic signal sections with an LED display module.

Lamp socket 'Screw-in' type products shall not be allowed for vehicle traffic signals.

1.2.2.1 Electrical

Provide modules that have maximum power consumption equal to or below the requirements of Table 1. Design the modules to operate from a 60 ± 3 HZ AC line voltage ranging from 80 volts to 135 volts. Ensure that fluctuations of line voltage have no visible effect on the luminous intensity of the indications. Design the module to have a normal operating voltage of 120 VAC, and measure all parameters at this voltage.

Certify that the module has a power factor of 0.90 or greater, and that THD (current and voltage) induced into an AC power line by the module does not exceed 20 percent for modules with power ratings above 15W, and 40 percent for modules with power ratings of 15W or less. Design the modules onboard circuitry to include voltage surge protection to withstand high repetition noise transients as stated in Section 2.1.6 of NEMA Standard TS-2, 1992. Ensure all wiring meets the requirements of Section 13.02 of the ITE Publication: Equipment and Material Standards, Chapter 2 (VTCSH). Provide spade terminals appropriate to the lead wires and sized for a #10 screw connection to the existing terminal block in a standard signal head.

Ensure that the module is compatible with signal load switches and conflict monitors. Design the module to provide sufficient current draw to ensure proper load switch operation while the voltage is

varied from a regulated 80Vrms to 135 Vrms. Design off-state for green and yellow modules to be 30Vrms or greater, and on-state to be 40Vrms or greater. Also for green and yellow modules, design the voltage decay to 10 Vrms or less to be 100 milliseconds or less. Ensure that the control circuitry prevents current flow through the LEDs in the off state to avoid a false indication.

Design all modules to meet existing SCDOT monitor specifications for the following type of signal monitors: 170 controller/cabinet Type 210, 2010 and 2010ECL conflict monitors (including red monitoring and so-called plus features such as dual indication detection and short yellow time detection).

Ensure that the modules and associated onboard circuitry meet Class A emission limits referred to in Federal Communications Commission (FCC) Title 47, Subpart B, Section 15 regulations concerning the emission of electronic noise.

1.2.2.2 Photometric and Chromaticity Requirements

The maintained minimum luminous intensity values for the modules are shown in Tables 2, and 4. Test all ball modules for luminous intensity at 25°C to meet 115% of values in table 2. Design and certify the modules to meet or exceed the maintained minimum luminous intensity values throughout the warranty period based on normal use in a traffic signal operation over the operating temperature range. Test the Red and Green modules for maintained luminous intensity (tables 2 & 3) at 74°C (ITE 6.4.2.2). Use LEDs that conform to the chromaticity requirements of VTCSH Chapter 2, Section 8.04 throughout the warranty period over the operating temperature range. Make chromaticity coordinate compliance measurements at 25°C.

1.2.2.3 Physical and Mechanical Requirements

Design the modules as retrofit replacements for installation into standard incandescent traffic sections that do not contain the incandescent lens, reflector assembly, lamp socket and lens gasket. Ensure that installation does not require special tools or physical modification for the existing fixture other than the removal of the incandescent lens, reflector assembly, lamp socket, and lens gasket.

1.2.2.4 Environmental Requirements

Provide modules that are rated for use in the operating temperature range of -40°C (-40°F) to +74°C (+165°F). Ensure that the modules (except yellow) meet all specifications throughout this range. Fabricate the module to protect the onboard circuitry against dust and moisture intrusion per the requirements of NEMA Standard 250-1991 for Type 4 enclosures to protect all internal components.

1.2.2.5 Module Construction

Design the module to be a single, self-contained device with the circuit board and power supply for the module inside and integral to the unit.

Design the assembly and manufacturing process for the module to ensure all internal components are adequately supported to withstand mechanical shock and vibration from high winds and other sources. Wire the individual LEDs such that a catastrophic loss or the failure of one LED will result in the loss of not more than 20 percent of the signal module light output. LEDs shall be soldered to the circuit board.

1.2.2.6 Materials

Fabricate the lens and signal module from material that conforms to ASTM specifications. Enclosures containing either the power supply or electronic components of the module shall be made of UL94VO flame retardant materials. The lens of the signal module is excluded from this requirement.

1.2.2.7 Module Identification

Permanently mark the manufacturer's name, trademark, model number, serial number, date of manufacture (month & year), and lot number as identification on the back of the module.

Permanently mark the following operating characteristics on the back of the module: rated voltage and rated power in Watts and Volt-Ampere.

If a specific mounting orientation is required, provide permanent markings consisting of an up arrow, or the word "UP" or "TOP" for correct indexing and orientation within the signal housing.

1.2.2.8 Lens

Provide a lens that is integral to the unit with a smooth outer surface and UV stabilized to withstand ultraviolet exposure for a minimum period of 60 months without exhibiting evidence of deterioration. Coat the front of a polycarbonate lens to make it more abrasion resistant. Seal the lens to the module to prevent moisture and dust from entering the module.

Tint the red and yellow lens to match the wavelength (chromaticity) of the LED. Provide a green lens that is either colorless or tinted to match the wavelength (chromaticity) of the LED.

1.2.2.9 12 Inch Arrow

The following specification requirements apply to the 12 inch (300 mm) arrow module only, which is the only size arrow allowed. All general specifications apply unless specifically superceded in this paragraph. Ensure that the arrow module meets specifications stated in Section 9.01 of the ITE VTCSH for arrow indications. Design arrow displays to be solid LEDs (spread evenly across the illuminated portion of the arrow or other designs) not outlines. Determine the luminous intensity using the CALTRANS 606 method or similar procedure. <http://itvendors.dot.ca.gov/hq/esc/ctms/ctmsindex600.html>

1.2.2.10 Testing

Provide test results for ball modules from an independent testing laboratory showing wattage and compliance with ITE VTCSH Part 2 specifications 6.4.2, 6.4.4.1, 6.4.4.2, 6.4.4.3, 6.4.5, and 6.4.6.1 as a minimum. The 6.4.2.1 test shall meet the requirements of Table 2 of this specification. The 6.4.2.2 test is for Red and Green only. Ensure that the LED signal modules tested are typical, average production units.

Burn In

Energize the sample module(s) (a sample of one module minimum) for a minimum of 24 hours, at 100 percent on-time duty cycle, at a temperature of +74°C (+165°F) before performing any qualification testing. Any failure of the module, which renders the unit non-compliant with the specification after burn-in, shall be cause for rejection. All specifications will be measured including, but not limited to:

Photometric (Rated Initial Luminous Intensity)

Measure at +25°C. Measure luminous intensity for red and green modules upon the completion of a 30 minute 100 percent on-time duty cycle at the rated voltage. Measure luminous intensity for yellow modules immediately upon energizing at the rated voltage.

Chromaticity (Color)

Measure at +25°C. Measure chromaticity for red and green modules upon the completion of a 30 minute 100 percent on-time duty cycle at the rated voltage. Measure chromaticity for yellow modules immediately upon energizing at the rated voltage.

Electrical

Measure all specified parameters for quality comparison of production quality assurance on production modules. (rated power, etc)

Equipment Compatibility

In addition to the 6.4.4.5 test of modules for compatibility with controllers, conflict monitors, and load switches, perform the following test, and certify the results. Connect each signal module to the output of a standard load switch connected to a variable AC voltage supply (95 to 135 VAC). With the load switch "off," vary the AC voltage from 95 Vrms to 135 Vrms, and measure the drop across the module. Readings greater than 15 Vrms are unacceptable.

1.2.2.11 Photometric Maintenance

Provide testing at an independent laboratory for a designated module to be tested for maintained luminous intensity at 25°C once each year during the five-year warranty period.

1.2.3 Tables

Table 1 Maximum Power Consumption (in Watts)

	Red	Yellow	Green
Temperature	25°C	25°C	25°C
12"(300 mm) circular	17	25	24
12"(300 mm) arrow	9	10	11

Table 2 Minimum Initial and maintained Intensities for Arrow Indications (in cd/m2)

	Red	Yellow	Green
Arrow Indication	5,500	11,000	11,000

Note: Use CALTRANS 606 method or similar procedure.

Table 3 Chromaticity Standards (CIE Chart)

Red	Y: not greater than 0.308, or less than 0.998 - x
Yellow	Y: not less than 0.411, nor less than 0.995 - x, nor less than 0.452
Green	Y: Not less than 0.506 - .519x, nor less than 0.150 + 1.068x, nor more than 0.730 - x

Table 4 Specification for 12 inch Extended View Signals in South Carolina

Minimum Luminous Intensity Values (In Candelas)			

Minimum Luminous Intensity Values (In Candelas)				
Expanded View Vertical Angle	Horizontal Angle (Left/Right)	RED	YELLOW	GREEN
+/-2.5	2.5	339	678	678
	7.5	251	501	501
	12.5	141	283	283
	17.5	77	154	154
+/-7.5	2.5	226	452	452
	7.5	202	404	404
	12.5	145	291	291
	17.5	89	178	178
	22.5	38	77	77
	27.5	16	32	32
+/-12.5	2.5	50	101	101
	7.5	48	97	97
	12.5	44	89	89
	17.5	34	69	69
	22.5	22	44	44
	27.5	16	32	32
+/-17.5	2.5	22	44	44
	7.5	22	44	44
	12.5	22	44	44
	17.5	22	44	44
	(Not Extended View)	20	41	41
	22.5	16	32	32
	(Not Extended View)			
+/-22.5	2.5	20	40	40
	17.5	20	40	40

Notes:

Design signal modules to meet these requirements as a minimum throughout the warranty period. Design signal modules to have a minimum initial intensity equal to 115% of Table 2 at 25°C. Independent laboratory test reports are required to validate the initial intensity.

1.2.4 Signal Backplate

A Signal Backplate constructed of thin strip of polycarbonate material that extends outward from and parallel to a signal face on all sides of a signal housing to provide a background for improved visibility of the signal locations shall be installed on all Signal Heads. Signal backplates shall be appropriate for the size and manufacturer of each signal head and be of monolithic construction. The backplate shall have a 2" retroreflective yellow border (Type XI (eleven) prismatic sheeting) applied, unless noted otherwise. See Standard Drawing for application.

1.2.5 Certification

CATALOG CUTS ARE REQUIRED

The Vendor shall provide written Certification from the Manufacturer that 1998 ITE STANDARDS have been met.

The Vendor shall provide design details and drawings in sufficient detail for complete evaluation and comparison with these Specifications. Any exceptions to these Specifications must be stated in writing at that time.

The Vendor shall provide written specifications (product sheets) for the specific POLYCARBONATE (LEXAN TYPE NO.) formulation that is proposed. Bids shall provide the tests results for the IZOD IMPACT tests.

Housing Type No. _____ or See Attached Letter _____

The Vendor shall provide written TEST RESULTS DEMONSTRATING THE STRENGTH OF THE 3-SECTION SIGNAL HEAD. The test signal shall not have the SCDOT aluminum bearing plate installed. The tests should include static stress and wind tunnel setups.

Sample modules shall be provided for Department approval upon request. The sample modules submitted shall be representative of typical average production units. Samples will not be returned unless requested by the vendor.

The manufacturer of LED Modules shall have previously supplied indications to other states or cities and shall supply a list of these cities and/or states with the bid. The reference shall include name of city or state, contact person and model number of the LED display(s) previously supplied.

Sample modules shall be provided for Department approval upon request. The sample modules submitted shall be representative of typical average production units. Samples will not be returned unless requested by the vendor.

1.2.6 Warranty

The Vendor shall furnish SCDOT a **60 month** warranty from purchase date on equipment, materials, modules and lamps that are provided by the Manufacturer or Vendor as normal trade practice.

Replacement shall be provided within 30 days of receipt of failed equipment at no cost to the Department (including shipping costs).

1.3 Measurement

Furnishing Polycarbonate Vehicle Signal Heads shall be measured by EACH type of head assembly with mounting hardware as specified, including ALL internal electrical connections and ALL required incidental hardware.

Furnishing Signal Backplate shall be measured by EACH including ALL required mounting hardware.

1.4 Payment

Furnishing Polycarbonate Vehicle Signal Heads with 12 inch sections unless noted, measured as provided above, will be paid for at the contract unit price

For Signal Heads:

FURNISH 12" 1-WAY-5 SECTION(R.Y.YA.G.GA)VEHICLE TRAFFIC SIGNAL	EA
FURNISH 12" 1-WAY-4 SECTION(RA+RA/YA.GA)VEHICLE TRAFFIC SIGNAL	EA
FURNISH 12" 1-WAY-4 SECTION(R.Y.G.GA)VEHICLE TRAFFIC SIGNAL	EA
FURNISH 12" 1-WAY-3 SECTION(R.Y.G.)VEHICLE TRAFFIC SIGNAL	EA
FURNISH 12" 1-WAY-3 SECTION(R.Y.GA.)VEHICLE TRAFFIC SIGNAL	EA
FURNISH 12" 1-WAY-3 SECTION(RA.YA.GA.)VEHICLE TRAFFIC SIGNAL	EA
FURNISH 1 WAY -3 SECTION (R(12").Y(12").Y(8"))VEHICLE TRAFFIC SIGNAL	EA
FURNISH 12" 4-WAY-1 SECT.(R.Y.R.Y.)CLUST. MOUNT CAUTION HEAD	EA
FURNISH 12" 1-WAY-1 SECTION(RED)VEHICLE TRAFFIC SIGNAL	EA
FURNISH 12" 1-WAY-1 SECTION(YELLOW)VEHICLE TRAFFIC SIGNAL	EA
FURNISH 12" 1-WAY-1 SECTION(GREEN)VEHICLE TRAFFIC SIGNAL	EA
FURNISH 12" 1-WAY-1 SECTION(RA)VEHICLE TRAFFIC SIGNAL	EA
FURNISH 12" 1-WAY-1 SECTION(YA)VEHICLE TRAFFIC SIGNAL	EA
FURNISH 12" 1-WAY-1 SECTION(GA)VEHICLE TRAFFIC SIGNAL	EA
FURNISH 8" 1-WAY-3 SECTION(R.Y.G.)VEHICLE TRAFFIC SIGNAL	EA
FURNISH 8" 1-WAY-1 SECTION(RED)VEHICLE TRAFFIC SIGNAL	EA
FURNISH 8" 1-WAY-1 SECTION(YELLOW)VEHICLE TRAFFIC SIGNAL	EA

For Signal Backplates:

FURNISH BACKPLATE W/ RETROREFLECTIVE BORDERS FOR TRAFFIC SIGNAL	EA
---	----

For LED Modules:

FURNISH 12" RED LED MODULE	EA
FURNISH 12" RED ARROW LED MODULE	EA
FURNISH 12" YELLOW LED MODULE	EA
FURNISH 12" YELLOW ARROW LED MODULE	EA
FURNISH 12" GREEN LED MODULE	EA
FURNISH 12" GREEN ARROW LED MODULE	EA

M686.3 FURNISH PEDESTRIAN SIGNAL HEADS

1.1 Description

This specification describes requirements for furnishing LED (Light Emitting Diode) PEDESTRIAN SIGNAL HEADS, with SUN VISOR and designated mounting hardware and LED (Light Emitting Diode) COUNTDOWN PEDESTRIAN SIGNAL HEADS, with SUN VISOR and designated mounting hardware, in accordance with these Specifications.

The pedestrian head and the mounting hardware are stated as one item.

1.2 Materials

1.2.1 Pedestrian Head

All signal heads shall conform to the specifications of the INSTITUTE OF TRANSPORTATION ENGINEERS (ITE), "Pedestrian Traffic Control Signal Indications" (March 2004). All pedestrian signal heads shall be furnished by the same manufacturer and shall be new and current production models. Pedestrian signal heads of the size, type, and arrangement specified, are to be furnished, together with ALL the necessary hardware for make-up and mounting. For the purpose of this Specification, the basic material requirements are listed below:

1.2.1.1 General

All pedestrian signal heads shall use a SOLID display LED HAND/MAN module as a light source; a nominal message bearing surface of 16 inches; and SYMBOLIC MESSAGES; a side-by-side display with the Portland Orange UPRIGHT HAND for "Don't Walk", and Lunar White WALKING MAN for "Walk" OR a countdown display with a nominal message bearing surface of 16 inches with a SOLID SYMBOLIC MESSAGE Hand/Man overlay on the left and the countdown on the right.

1.2.1.2 Housing, Visor

The housing shall be a one piece ultra-stabilized, permanently colored, flame-retardant, PURE Polycarbonate resin. The materials and construction used shall comply with ITE Standards. A single housing shall contain the LED module. A weather tight neoprene gasket shall be provided. All hardware shall be stainless steel or aluminum. The DOOR shall swing down with two hidden hinges at the bottom, with removable locking pins. The DOOR shall be a corrosion resistant one-piece aluminum alloy die-casting, and pins.

A visor shall also be furnished and shall be securely fastened with corrosion resistant screws to the front of the signal housing, to shield the lens from the sun.

1.2.1.4 Finish

The finish colors shall be FEDERAL YELLOW (13538) for the door, housing, and exterior surfaces of the visor; and FLAT BLACK (37038) for the inside of the visor and for the part of the door within the visor. The colors shall be fade resistant for a minimum of five years.

1.2.1.5 Mounting

Brackets and related hardware shall be furnished for properly installing the pedestrian signal heads.

For ***single post-top mount***:

A 1½" aluminum post top signal mounting shall be furnished. It shall consist of a slip fitter assembly for a one-way signal. It should be Pelco Product Part Number SE-3037 or equivalent with a FEDERAL YELLOW finish. See Diagram 1.

For ***dual post-top mount***:

A 1½" aluminum post top signal mounting shall be furnished. It shall consist of a slip fitter for 1- and 2-way signal heads with a 4 inch slip-fitter bracket with a set screw, a lower mounting assembly, a support tube, and an upper mounting assembly. This mounting assembly should be Pelco Product Part Number SE-3257 or equivalent with a FEDERAL YELLOW finish. See Diagram 2.

**Diagram 1.
Single Post-
Top Mount**

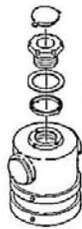

**Diagram 2.
Dual Post-Top
Mount**

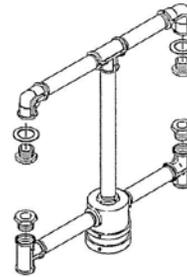

For ***side-of-pole mount***:

A CLAMSHELL mount shall be furnished, compatible with a 4-1/2 inch and larger pole. The clamshell mount shall be compatible with either bolt mounting (to a wood pole), or band-on mounting to a steel pole. The side-mount shall make provisions for a hinge, and for wiring and terminal block. All hardware shall be tamper resistant. See Diagram 3.

A 1½" aluminum side-of-pole signal mounting shall be furnished. It shall consist of hub plates with conduit openings, and upper and lower arm assemblies for a 1-way signal. This mounting assembly should be Pelco Product Part Number SP-5523 or equivalent with a FEDERAL YELLOW finish. See the Diagram 4.

**Diagram 3.
Clamshell Mount**

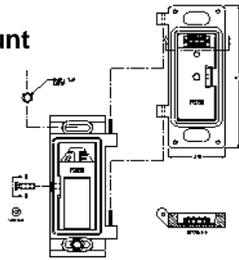

**Diagram 4.
Side-of-pole Mount**

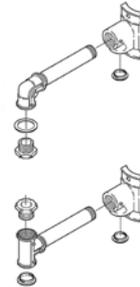

Locking devices equivalent to serrated washers shall be furnished with each type of mounting brackets, so that the pedestrian signal heads may be firmly and positively held in their required alignment.

1.2.2 Hand/Man LED Module and Hand/Man COUNTDOWN LED Module

Each LED module supplied shall be factory installed in the pedestrian signal head or shipped as a complete module with weather tight neoprene gasket to retrofit existing SCDOT polycarbonate pedestrian signal heads if applicable. Design the LED pedestrian signal module for installation into existing standard pedestrian signal head that does not contain the incandescent signal section reflector, lens, egg crate visor, gasket, or socket and requires no other physical modifications to the existing pedestrian signal head.

Identify each module with the manufacturer's name, model number, serial number, date of manufacture, and lot number if applicable per section 3.6 of "The Equipment and Materials Standards" of the Institute of Transportation Engineers "Vehicular Traffic Control Signal Heads" (VTCSH) Part 2, Chapter 2A.

The lens shall be a clear, non-glare, non-frosted polymeric lens with a matte finish. It shall be UV stabilized to withstand ultraviolet exposure for a minimum period of 60 months without exhibiting evidence of deterioration. Coat the front surface of the lens to make it more abrasion resistant. Ensure that the lens has light transmission properties equal to or greater than 80%.

1.2.2.1 Optical

Comply with the following sections: 3.3, 3.5, 3.6, 5.2, 5.3, 5.7, 6.1, 6.3.1, 6.3.3, 6.3.4, 6.4.4, and 6.4.5 of The Equipment and Materials Standards of the INSTITUTE OF TRANSPORTATION ENGINEERS (ITE), "Pedestrian Traffic Control Signal Indications – Part 2: Light Emitting Diode (LED) Pedestrian Traffic Signal Module" (March 2004) unless otherwise specified.

LED Hand/Man Module

Provide **16 inch displays** that have SOLID Symbolic Messages that meet the dimension requirements cited in Chapter 3, Table 1 *Dimensions of Signal Sizes* for Class 3 displays (minimum 11 inches high and 7 inches in width each). The LED hand/Man symbols shall be a side-by-side display. Configure the pedestrian signal module with a sufficient number of LEDs to provide an average luminous intensity of at least 3750 candela per square meter of lighting surface for the "RAISED HAND", and 5300 candela per square meter of lighting surface for the "WALKING MAN". Ensure they meet this average luminous intensity throughout the warranty period over the operating temperature range. Wire the LEDs such that a catastrophic loss or failure of one or more LEDs will result in the loss of not more than five percent of the pedestrian signal module light output.

LED Hand/Man Countdown Module

Provide **16 inch displays** that have SOLID Symbolic Messages that meet the dimension requirements cited in Chapter 3, Table 1 *Dimensions of Signal Sizes* for Class 3 displays. Ensure that the countdown number display is a minimum of 7 inches high by 6 inches wide. The LED hand/Man symbols shall be an overlay display. Configure the pedestrian signal module with a sufficient number of LEDs to provide an average luminous intensity of at least 3750 candela per square meter of lighting surface for the "RAISED HAND" and "COUNTDOWN", and 5300 candela per square meter of lighting surface for the "WALKING MAN". Ensure they meet this average luminous intensity throughout the warranty period over the operating temperature range. Wire the LEDs such that a catastrophic loss or failure of one or more LEDs will result in the loss of not more than five percent of the pedestrian signal module light output.

Design the countdown display as a double row of LEDs, and ensure the countdown display blanks-out during the initial cycle while it records the countdown time. Ensure that the countdown display is operational only during the flashing don't walk, clearance interval. Blank out the countdown indication after it reaches zero until the beginning of the next flashing don't walk indication, and design the controlling circuitry to prevent the timer from being triggered during the solid hand indication.

Provide written certification that the pedestrian signal module complies with the sections of the ITE specifications identified in this section. Provide written independent testing laboratory results showing that the LED Hand/Man and the LED Hand/Man Countdown Modules meet or exceed the luminous intensity requirements of this specification.

Portland Orange LEDs for the hand and countdown shall be of the latest AlInGaP technology or higher and Lunar White LEDs for the man shall be of the latest InGaN technology or higher.

1.2.2.2 Electrical

Ensure that LED modules are compatible with signal load switches and conflict monitors meeting NEMA Standard TS 1 - 1989. Design the module to provide sufficient current draw to ensure proper load switch operation while the voltage is varied from a regulated 80Vrms to 135Vrms. Provide control circuitry to prevent current flow through the LEDs in the off state to avoid a false indication. Design all modules to meet existing SCDOT monitor specifications for the following types of signal monitors: 170 cabinet/controller compatible SCDOT specified Type 210, Type 2010, Type 2010ECL, and Type 2010ECL-ip conflict monitors (including red monitoring and so-called plus features such as dual indication detection and short yellow time detection).

Provide lead wires that are eighteen gauge (18AWG) minimum copper conductors with 105 degree Celsius insulation. There shall be no more than three lead wires exiting the unit with no external splices. Lead wires shall be a minimum of 30 inches long with NEMA "spade" terminals that are appropriate to the lead wires and sized for a #10 screw connection to the existing terminal block in the pedestrian signal head.

The LED's shall be soldered to the circuit board.

Ensure that the power consumption for the pedestrian signal modules is equal to or less than the following in watts,

TEMPERATURE	25°C	74°C
HAND	10	12
MAN	9	12
COUNTDOWN	9	12

1.2.3 Packaging

Each single pedestrian signal head, complete with visor and LED specified, completely assembled and designated mounting assembly, shall be packaged in a separate corrugated cardboard box. It shall be clearly labeled on the END of the box, in English, as to the type of mounting assembly contained therein.

Each style of retrofit module complete with weather tight neoprene gasket shall be packaged in a separate corrugated cardboard box. It shall be clearly labeled on the END of the box, in English.

1.2.4 Certification

CATALOG CUTS ARE REQUIRED

Vendor shall provide written Certification from the intended Manufacturer, that ITE Standards have been met for heads and modules.

The Manufacturer shall have previously supplied indications to other states or cities and shall supply a list of these cities and/or states with the bid as references. The references shall include name of city or state, contact person, phone number, and model number of the LED display(s) previously supplied. Failure to submit references upon request shall be grounds for rejection of the bid.

The Vendor SHALL FURNISH, the design details and drawings in sufficient detail for complete evaluation of the Proposal, and comparison with these Specifications. Any exceptions to these Specifications must be stated in writing at that time.

Sample modules shall be provided for Department approval upon request. The sample modules submitted shall be representative of typical average production units. **Samples will not be returned unless requested by the vendor.**

1.2.5 Warranty

During the period of **24 months** following the date of purchase, the Manufacturer or Vendor shall replace, at no expense to the Department (including shipping costs), any part of Polycarbonate Pedestrian Signal Head, Pedestrian LED Module, or Mounting hardware that fails by reason of defective material or workmanship.

Performance shall be warranted for a period of **60 months** of the date of purchase and shall include repair or replacement of an LED pedestrian module that exhibits light output degradation which in the judgment of the department, cannot be easily seen at 150 feet in bright sunlight with the visor on the housing or that drops below the luminous intensity output requirements of section 1.2.2.1 of this specification. Failure due to workmanship, materials, and manufacturing defects shall be warranted for repair or replacement of the first 60 months of the date of purchase. The vendor shall replace any failed modules within 30 calendar days of notification.

1.3 Measurement

Furnishing Pedestrian Signal Heads will be measured by EACH type of head assembly and/or mounting method specified with LED module installed, including ALL internal electrical connections and all incidental hardware.

1.4 Payment

Furnishing Pedestrian Signal Heads with LED modules and clamshell mounts, measured as provided above, will be paid at the contract unit price bid for:

FURNISH 1-WAY-1 SECTION PEDESTRIAN SIGNAL HEAD W/ HAND/MAN LED MODULE AND CLAMSHELL MOUNT FOR SIDE POLE (LEFT)	EA
FURNISH 1-WAY-1 SECTION PEDESTRIAN SIGNAL HEAD W/ HAND/MAN LED MODULE AND CLAMSHELL MOUNT FOR SIDE POLE (RIGHT)	EA
FURNISH 1-WAY-1 SECTION PEDESTRIAN SIGNAL HEAD W/ HAND/MAN COUNTDOWN LED MODULE AND CLAMSHELL MOUNT FOR SIDE POLE (LEFT)	EA
FURNISH 1-WAY-1 SECTION PEDESTRIAN SIGNAL HEAD W/ HAND/MAN COUNTDOWN LED MODULE AND CLAMSHELL MOUNT FOR SIDE POLE (RIGHT)	EA

Furnishing Pedestrian Signal Heads with LED modules (no mounting hardware included), measured as provided above, will be paid at the contract unit price bid for:

FURNISH 1-WAY-1 SECTION PEDESTRIAN SIGNAL HEAD W/ HAND/MAN LED MODULE	EA
FURNISH 1-WAY-1 SECTION PEDESTRIAN SIGNAL HEAD W/ HAND/MAN COUNTDOWN LED MODULE	EA

Furnishing mounting hardware, measured as provided above, will be paid at the contract unit price bid for:

FURNISH PEDESTRIAN TRAFFIC SIGNAL HEAD MOUNTING ASSEMBLY FOR POST TOP	EA
FURNISH PEDESTRIAN TRAFFIC SIGNAL HEAD MOUNTING ASSEMBLY FOR SIDE POLE	EA
FURNISH PEDESTRIAN TRAFFIC SIGNAL HEAD MOUNTING ASSEMBLY FOR DUAL POST TOP	EA

Furnishing hand/man LED module or hand/man countdown LED module, measured by EACH, shall be complete with weather tight neoprene gasket for retrofitting existing pedestrian signal heads if applicable and shall be paid at the contract unit price bid for:

FURNISH HAND/MAN LED MODULE	EA
FURNISH HAND/MAN COUNTDOWN LED MODULE	EA

Furnishing visor with attachment screws (corrosion resistant) for retrofitting existing pedestrian signal heads for LED module use, measured by EACH, shall be paid at the contract unit price bid for:

FURNISH VISOR WITH ATTACHMENT SCREWS	EA
--------------------------------------	----

M686.4 FURNISH PEDESTRIAN PUSH BUTTON STATION ASSEMBLY WITH SIGN**1.1 Description**

This specification describes requirements for furnishing AMERICAN DISABILITIES ACT APPROVED ALUMINUM PEDESTRIAN PUSH BUTTON STATION ASSEMBLIES AND PUSH BUTTON SIGNS.

1.2 Materials**1.2.1 Aluminum Push Button Station Assemblies**

Each aluminum push button station assembly shall conform to the specifications as set forth by the AMERICAN DISABILITIES ACT (ADA). Each aluminum push button station assembly shall be provided with an adjoining sign and must be able to accommodate to the size of the specified sign (either 9 x 12 inch or 9 x 15 inch).

1.2.2 Push Buttons (with or without adjoining sign)

The long life switch shall be actuated by a 2 inch diameter chrome plated button and shall be included into a vandal resistant one-piece cast aluminum assembly and include a cable guide. All/any exposed screws on the push button station assembly shall be stainless steel or other rust resistant material, and be tamper-proof. There shall be no sharp edges.

1.2.3 Finish

The finish color shall be FEDERAL YELLOW (13538) for the aluminum push button station assembly
The push button shall operate on a circuit not to exceed 24 Volts.

1.2.1 Push Button Signs

Each aluminum push button station assembly shall be provided with an adjoining sign.

The push button sign shall be aluminum with minimum thickness of 0.1 inch, with rounded corners, and have a black legend on white background. **The message shall be in accordance with the MANUAL ON UNIFORM TRAFFIC CONTROL DEVICES FOR STREETS AND HIGHWAYS (latest edition).**

The signs shall be 9 x 12 inch for:

R10-3 "PUSH BUTTON FOR GREEN LIGHT" when used without Pedestrian Signal Heads (see diagram below)

R10-3b "TO CROSS PUSH BUTTON (MAN WALK SYMBOL W/DEFINITIONS) ← → (arrow-left/right)" when used with hand/man Pedestrian Signal Heads The sign shall be reversible, such that one side displays the message with a left arrow and the other side displays the message with a right arrow (see diagram below).



R10-3



R10-3b

or should be 9 x 15 inch for:

R10-3e "TO CROSS PUSH BUTTON (COUNTDOWN)" when used with countdown Pedestrian Signal Heads The sign shall be reversible, such that one side displays the message with a left arrow and the other side displays the message with a right arrow (see diagram below).



R10-3e

1.2.2 Certification

CATALOG CUTS ARE REQUIRED

Provide written Certification from the intended Manufacturer, that ADA SPECIFICATIONS have been met for push buttons.

Provide design details and drawings sufficiently detailed. This is necessary for a complete evaluation of the Proposal, and comparison with these Specifications. Any exceptions to these Specifications must be stated in writing at that time.

Samples of each of the aluminum Pedestrian Push Button Station Assemblies and Signs shall be for Department approval upon request. The samples submitted shall be representative of typical average production units. **Samples will not be returned unless requested by the vendor.**

1.2.3 Warranty

During the period of **12 months** following the date of purchase, the Manufacturer or Vendor shall replace, at no expense to the Department (including shipping costs), any part of the Pedestrian Push Button Station Assembly, Sign or Bracket that fails by reason of defective material or workmanship.

1.3 Measurement

Furnishing a Pedestrian Push Button Station Assembly and Sign will be measured by EACH unit, including all dual mounting brackets and incidental hardware.

Furnishing a Sign will be measured by EACH unit.

1.4 Payment

Furnishing a Pedestrian Push Button Station Assembly and Sign, measured as provided above, will be paid for at the contract unit price bid for:

FURNISH PEDESTRIAN PUSH BUTTON MICROSWITCH TYPE STATION ASSEMBLY (9"x12") AND SIGN (R-10-3E)	EA
FURNISH PEDESTRIAN PUSH BUTTON MICROSWITCH TYPE STATION ASSEMBLY (9"x15") AND SIGN (R-10-3E)	EA
FURNISH PEDESTRIAN PUSH BUTTON MICROSWITCH TYPE	EA
FURNISH PEDESTRIAN PUSH BUTTON SOLID STATE WITH LIGHT AND TONE STATION ASSEMBLY (9"x12") AND SIGN (R-10-3E)	EA
FURNISH PEDESTRIAN PUSH BUTTON SOLID STATE WITH LIGHT AND TONE STATION ASSEMBLY (9"x15") AND SIGN (R-10-3E)	EA
FURNISH PEDESTRIAN PUSH BUTTON SOLID STATE WITH LIGHT AND TONE	EA
FURNISH DOUBLE MOUNTING BRACKET(S) FOR (9 X 15 inch) SIGN	EA
FURNISH 20' SPUN ALUMINUM PEDESTRIAN POLE 4 1/2" DIAMETER	EA

For Signs:

FURNISH SIGN R10-3 (PUSH BUTTON FOR GREEN LIGHT)	EA
FURNISH SIGN R10-3b "TO CROSS PUSH (MAN/WALK SYMBOL WITH DEFINITIONS)" REVERSABLE FOR ARROWS IN BOTH DIRECTIONS	EA
FURNISH SIGN R10-3e "TO CROSS PUSH BUTTON (COUNTDOWN - ARROW)" REVERSABLE FOR ARROWS IN BOTH DIRECTIONS	EA

M686.5 FURNISH SYMBOLIC LED BLANKOUT SIGN

1.1 Description

This specification describes requirements for furnishing Symbolic LED (Light Emitting Diode) No Right/Left Turn Blankout Sign, of Clam-Shell configuration, with Sun Visor and designated mounting hardware. The Blankout Sign and the mounting hardware are stated as one item.

1.2 Materials

1.2.1 Blankout Sign

All Blankout Signs shall be built to Institute of Transportation Engineers "Vehicular Traffic Control Signal Heads" (VTCSH) standards. All Blankout Sign housings shall be furnished by the same manufacturer and shall be new and current production models. The Blankout Sign shall be capable of displaying three distinct messages including blank message. The furnished Blankout Sign shall include all electrical and electronic hardware, structural materials, housings, and all the necessary hardware for make-up and mounting. The Blankout Sign, and its associated equipment, shall be capable of operating on a 24 hour a day, 7 day per week basis and shall conform to the physical and functional requirements of this Specification.

1.2.1.1 Symbol

All blankout signs shall use an illumination of International Symbol consisting of a red circle and slash and either a white right arrow or white left arrow. Symbols shall conform to MUTCD sign standards. When the display is not energized, the sign shall be effectively blank. The Symbol shall be illuminated by an assembly of high output lunar white and red LEDs.

1.2.1.2 Housing

The housing shall be a constructed of Aluminum and shall be weatherproof. The outside dimensions shall not be less than 26 inches high by 26 inches wide and 4 inches deep. The housing shall not be less than 0.125 inch aluminum with all corners being welded their full length. All welds shall use the tungsten inert gas method. A fitting shall be installed on the bottom of the sign in the middle for tethering. The back shall be aluminum of not less than 0.063 inches thick. The door shall be extruded aluminum of not less than 0.125 inch thickness and shall be welded on two corners and screwed together on the other two corners to provide access for installation of a faceplate and polycarbonate lens. The aluminum door shall be attached to the housing utilizing stainless steel hinges. The door shall be held secure to a neoprene gasket by stainless steel, quarter turn link locks. All hardware shall be stainless steel and no tools shall be required for routine maintenance. A retaining rod shall be provided to secure the door in the open position.

1.2.1.3 Visor

A three sided aluminum visor of not less than 0.063 inch thickness and 7 inches deep shall also be furnished and shall be securely fastened with corrosion resistant screws to the aluminum door, to shield the lens from the sun.

1.2.1.5 Finish

The finish colors shall be FEDERAL YELLOW (13538) for the door, exterior and interior of the sign enclosure, and exterior surfaces of the visor. Apply the yellow by the dry powder method. Apply the yellow finish by electrostatic spray and heat cure. Ensure the thickness of the finish is a minimum of 2.5 mils thick. Do not apply paint to the latching hardware. Paint two coats of FLAT BLACK (37038) for the inside of the visor, and for the part of the door within the visor.

1.2.1.6 Mounting

All mounting hardware shall be furnished for Span-Wire mounting, as requested by the purchase order. Hardware for Span-Wire shall be finished FEDERAL YELLOW (13538).

For Span-Wire mounting, the HANGER shall be cast ALUMINUM, and shall contain two (2) stainless steel J-Hooks with stainless steel lock washers and nuts, and have seven (7) notches to position the hanging signal. A double weatherhead entrance shall be used. The weatherhead entrance BUSHING shall have a 1.5 inch hole for wire entry. That entrance diameter shall be maintained throughout the weatherhead, without restriction or reducing the hole diameter, into the sign. No special tools shall be required to tighten or adjust signs. Span wire hangers shall not require disassembly to install on span wire.

A fastener shall be installed in the bottom of the sign housing to provide for attachment to a tether cable of ¼ inch diameter.

1.2.2 *Symbolic LED Module*

Provide a symbolic display that is a PCB (Printed Circuit Board) matrix with a mat black solder mask with minimum thickness of 0.093 inches and a silk screened component identifier. Mount LEDs on front of the PCB matrix. Mount all other components on the back of the black matrix. Ensure that a person with 20/20 vision can read a fully intensified, legible message from 500 feet in front of the sign under any light conditions. Ensure the message is not legible when the sign is off, even if in direct sunlight.

Design and certify the LED Blankout Sign to operate over a temperature range of -40°F to 165°F with an operating voltage range of 105 to 130 volts and a power factor >95%. Ensure that all electronic components are standard industry items that are available from wholesale electronics distributors. Provide components that are "solid state" type. Do not use electro-mechanical components such as relays, transformers or solenoids.

Ensure compatibility and proper triggering and operation with load switches and conflict monitors in signal controllers currently used by the Department. Ensure the on-board circuitry meets FCC title 47, sub-part B, section 15 regulations on the emission of electronic noise. The presence of ambient radio signals, magnetic or electromagnetic interference, including those from power lines, roadway lights, transformers or motors, within 1 foot of any of the components of the Blankout Sign, shall not impair the performance of the Blankout Sign. The Blankout Sign shall not radiate any electrical or electromagnetic signals that could adversely affect any other electrical or electronic device.

1.2.2.1 LED Specifications

Use Red LEDs that are the latest Aluminum Indium Gallium Phosphide (AlInGaP) technology and White LEDs that are the latest Indium Gallium Nitride (InGaN) technology or better with a minimum luminous output requirement of 9,000 candelas per meter square when each discrete LED is driven at a current of 20 milliamperes. Install the ultra-bright type LEDs that are rated for 100,000 hours of elapsed time calendar hours use in an ambient temperatures, based on an average daily on-time usage factor of 11%, when driven at the specific forward current used for normal daylight LED Blankout Sign display

operation. Distribute the LEDs evenly. Ensure that the maximum distance, center to center, between consecutive LEDs is 0.5 inches, plus or minus 10%. Connect the individual LED light sources so that failure of a single LED will result in a loss of no more than 5 LEDs. Protect and seal the rear side of the PCB with a molded polymeric back cover. Mount the display PCB with back cover into the front door, which consist of an aluminum frame and face lens.

The LED driver electronics shall not be mounted on the same board as the LED displays. The driver boards shall be easily disconnected from the LED display modules. Removal of any display module shall not affect the operation of the remaining modules.

1.2.2.2 Lens

Provide a clear, non-glare, mat finish polycarbonate lens with a UV resistant surface treatment and super abrasion resistant properties. Ensure that the lens has light transmission properties equal to or greater than 80%. The module shall be completely sealed against moisture and dust intrusion.

1.2.2.3 Dimming

Provide a photocell and dimming circuitry to automatically reduce the light intensity of the display by 35% based on the ambient light to reduce long term degradation of the LEDs. Include a 30-second delay to prevent interference caused by extraneous light.

1.2.2.4 Labels

Identify each Symbolic LED Module with the manufacturer's name, model number, serial number, date of manufacture, and lot number if applicable.

1.2.3 *Packaging*

Each single Symbolic Blankout Sign, complete with visor, and LED Symbolic module capable of displaying either a right or left arrow, as specified, completely assembled with mounting assembly and tether fastener, shall be packaged in a separate corrugated cardboard box. The box shall be clearly labeled on the END of the box, in plain English, as to what's contained therein. All packages shall be identified with the Department PURCHASE ORDER NUMBER. Packing lists and EQUIPMENT LABELS shall be glued to every carton showing its contents.

Each Symbolic LED Module shall be packaged in a separate corrugated cardboard box. The box shall be clearly labeled on the END of the box, in plain English, as to what's contained therein. All packages shall be identified with the Department PURCHASE ORDER NUMBER. Packing lists and EQUIPMENT LABELS shall be glued to every carton showing its contents.

1.2.4 *Certification*

CATALOG CUTS ARE REQUIRED

Provide written Certification from the **Manufacturer or Vendor** that ITE Standards, MUTCD standards, and all the requirements of this specification have been met.

Samples shall be provided for Department approval if requested. The sample submitted shall be representative of typical average production units. Samples will not be returned unless requested by the vendor.

1.2.5 Warranty

During the period of **SIXTY (60) MONTHS** following the date of purchase, the Manufacturer or Vendor shall replace, at no expense to the Department (including shipping costs), any part of Symbolic LED Blankout Sign that fails by reason of defective material or workmanship.

Performance shall be warranted for a period of **SIXTY (60) MONTHS** of the date of purchase and shall include repair or replacement of a Symbolic LED NRT/NLT Module that exhibits light output degradation, which in the judgment of the department, cannot be easily seen at one hundred fifty feet (150') in bright sunlight with the visor on the housing or that drops below the luminous intensity output requirements of this specification. The vendor shall replace any failed modules within 30 calendar days of notification.

1.3 Measurement

Furnishing a No Right/Left Turn Symbolic LED Blankout Sign shall be measured by EACH with LED module installed, including ALL internal electrical and electronic hardware, structural materials, housings, and all the necessary hardware for proper mounting.

Furnishing a No Right/Left Turn Symbolic LED Module, measured by each, shall be complete with weather tight neoprene gasket for replacing defective existing modules if applicable.

1.4 Payment

Furnishing a No Right/Left Turn Symbolic LED Blankout Sign with LED module with span wire mount, measured as provided above, will be paid at the contract unit price bid for:

FURNISH NO RIGHT/LEFT TURN SYMBOLIC LED BLANKOUT SIGN W/ SPAN WIRE MOUNTING	EA
---	----

Furnishing a Symbolic LED module, measured as provided above, will be paid at the contract unit price bid for:

FURNISH NO RIGHT/LEFT TURN SYMBOLIC LED MODULE	EA
--	----

M688.3 FURNISH VIDEO DETECTION - LOOP EMULATION SYSTEM

1.1 Description

This specification describes requirements for furnishing video imaging loop emulation detection systems components with all necessary hardware and software. A complete Video Detection System includes Camera, Camera Mounting Hardware, Camera Cable, CPU, Surge Arrestors, and Power Panel.

1.2 Materials

1.2.1 Video Imaging

Material and equipment furnished under this section must be pre-approved by SCDOT by the date of installation. Miscellaneous hardware such as cables and mounting hardware do not need to be pre-approved.

Ensure that software is licensed for use by SCDOT and by any other agency responsible for maintaining or operating the loop emulation system.

Design and furnish video imaging loop emulator detection systems that detect vehicles at signalized intersections by processing video images and providing detection outputs to the signal controller in real time (within 150 milliseconds of vehicle arrival).

Furnish all required camera sensor units, loop emulation processor units, hardware and software packages, cabling, luminaire arms, harnesses, camera mounting assemblies, surge protection panels, grounding systems and all necessary hardware. Furnish systems that allow the display of detection zones superimposed on an image of the roadway on an SCDOT-furnished monitor or laptop computer screen. Ensure detection zones can be defined and data entered using a simple keyboard or mouse and monitor, or using a Windows® Xp (or newer) based laptop PC with software.

Provide design drawings showing design details and camera sensor unit locations for review and acceptance before installation. Provide mounting height and location requirements for camera sensor units on the design, based on site-survey. Design video imaging loop emulation detection systems with all necessary hardware. Indicate all necessary poles, spans, mast arms, luminaire arms, cables, camera mounting assemblies and hardware to achieve the required detection zones where SCDOT owned poles are not adequate to locate the camera sensor units. The vendor is responsible for the final design of video imaging loop emulation detection systems.

Review and acceptance of the designs by SCDOT does not relieve the vendor from the responsibility to provide fully functional systems and to ensure that the required detection zones can be provided.

Provide the ability to program each detection call with the following functions:

- Full Time Delay – Delay timer is active continuously,
- Normal Delay – Delay timer is inhibited when assigned phase is green (except when used with TS 2 and 170/2070L controllers),
- Extend – Call is extended for this amount of time after vehicle leaves detection area,

- Delay Call/Extend Call – This feature uses a combination of full time delay and extend time on the same detection call. Ensure operation is as follows: Vehicle calls are received after the delay timer times out. When a call is detected, it is held until the detection area is empty and the programmed extend time expires. If another vehicle enters the detection area before the extend timer times out, the call is held and the extend timer is reset. When the extend timer times out, the delay timer has to expire before another vehicle call can be received.

Provide the ability to program each detection zone as one of the following functions:

- Presence detector,
- Directional presence detector,
- Pulse detector,
- Directional pulse detector.

Ensure previously defined detector zones and configurations can be edited.

Provide systems that allow for the placement of at least 8 detection zones within the combined field of view of a single camera sensor unit.

Provide a minimum of 4 detection outputs per loop emulation processing unit. If additional outputs are needed, provide all necessary hardware to allow for additional calls to be placed to the Controller via the input file.

Provide detection zones that can be overlapped. Ensure systems reliably detect vehicles when the horizontal distance from the camera sensor unit to the detection zone area is less than ten times the mounting height of the sensor. Ensure systems detect vehicles in multiple travel lanes.

Ensure systems can detect vehicle presence within 98 to 102 percent accuracy (up to 2 percent of the vehicles missed and up to 2 percent of false detection) for all weather and lighting conditions, in the absence of occlusion.

SCDOT may conduct field-testing to ensure the accuracy of completed video imaging loop emulation detection systems.

1.2.2 Loop Emulation System

Furnish loop emulator systems that receive and simultaneously process information from camera sensor units, and provides detector outputs to signal controllers.

Ensure systems provide the following:

- Operate in a typical roadside environment and meet the environmental specifications and are fully compatible with NEMA TS 1, NEMA TS 2, or Type 170/2070L controllers and cabinets,
- provide a “fail-safe” mode whereby failure of one or more of the camera sensor units will cause constant calls to be placed on the affected vehicle detection outputs to the signal controller,
- provide compensation for minor camera movement of up to 2 percent of the field of view at 400 feet without falsely detecting vehicles,
- process the video at a minimum rate of 30 frames per second,
- provide separate wired connectors inside the controller cabinet for viewing each camera,

Furnish camera sensor units that comply with the following:

- have an output signal conforming to EIA RS-170 standard,
- have a nominal output impedance of 75 ohms,
- be immune to bright light sources, or have built in circuitry or protective devices to prevent damage to the sensor when pointed directly at strong light sources,
- be housed in a light colored environmental enclosure that is water proof and dust tight, and that conforms to NEMA-4 specifications or better,
- simultaneously monitor at least five travel lanes when placed at the proper mounting location with a zoom lens,
- have a sunshield attached to the environmental enclosure to minimize solar heating,
- meet FCC class B requirements for electromagnetic interference emissions,
- have a heater attached to the viewing window of the environmental enclosure to prevent ice and condensation in cold weather.

Where coaxial video cables and other cables are required between the camera sensor and other components located in the controller cabinet, furnish surge protection in the controller cabinet.

Coaxial communications cable shall comply with the following, as recommended by the approved loop emulation manufacturer:

- Belden 8281 or approved equivalent Number 20 AWG, solid bare copper conductor terminated with crimped-on BNC connectors (do not use BNC adapters) from the camera sensor to the signal controller cabinet.
- Belden 9259 or approved equivalent Number 22 AWG, stranded bare copper conductor terminated with crimped-on BNC connectors (do not use BNC adapters) from the camera sensor unit to the junction box, and within the signal controller cabinet.

Furnish power cable appropriately sized to meet the power requirements of the sensors. At a minimum, provide three conductor 120 VAC field power cable.

As determined during the site survey, furnish sensor junction boxes with nominal 6 x 10 x 6 inches dimensions at each sensor location. Provide terminal blocks and tie points for power cable.

1.2.1 Video Imaging Loop Emulator System Support

Furnish video imaging loop emulation systems with either a simple keyboard or a mouse with monitor and appropriate software, or with system software for use on SCDOT-owned laptop PCs. Ensure the system is Windows® 2000 compatible, or newer.

Provide Hardware and Windows® XP compatible (or newer) personal computer software, if needed, to provide remote video and video detection monitoring via standard telephone line.

Provide each individual system with all the necessary equipment to focus and zoom the camera lenses without the need to enter the camera enclosure.

Ensure systems allow the user to edit previously defined detector configurations. When a vehicle is within a detection zone, provide for a change in color or intensity of the detection zone perimeter or other appropriate display change on the monitor or laptop computer screen.

Provide cabling and interconnection hardware with 6-foot minimum length interconnection cable to interface with the system.

Provide all associated equipment manuals and documentation.

1.2.2 Warranty

The Vendor shall furnish SCDOT with any warranties on equipment and materials that are provided by the Manufacturer or Vendor as normal trade practice.

1.3 Measurement

Furnishing Video Detection System components shall be measured as EACH unit.

Furnishing Video Detection Camera Cable shall be measured by LINEAR FEET and furnished in 500' REELS or 1000' REELS.

Furnishing Video Detection System On Site Training shall be measured by DAY.

1.4 Payment

Furnishing Video Detection System components, Cable, and On Site Assistance, measured as provided above, will be paid for at the contract unit price for:

FURNISH VIDEO DETECTION CPU	EA
FURNISH VIDEO DETECTION CAMERA	EA
FURNISH VIDEO DETECTION CAMERA MOUNTING HARDWARE	EA
FURNISH VIDEO DETECTION CAMERA CABLE – 1000'	1000' REEL
FURNISH VIDEO DETECTION CAMERA CABLE – 500'	500' REEL
FURNISH MONITOR WITH VIDEO CABLE	EA
FURNISH VIDEO DETECTION ON SITE ASSISTANCE	DAY
FURNISH VIDEO DETECTION SURGE ARRESTORS	EA
FURNISH VIDEO DETECTION POWER PANEL WITH BREAKER	EA
FURNISH VIDEO DETECTION LENS ADJUSTMENT MODULE	EA

M688.5 FURNISH STEEL STRAIN POLE AND FOUNDATION

1.1 Description

This specification describes requirements for furnishing a Steel Strain Pole, of the sizes and colors specified. Anchor bolts and all miscellaneous hardware shall be supplied with each pole as required.

Anchor bolts and all miscellaneous hardware shall be supplied with each pole as required. All anchor bolt nuts, caps, pole clamps, and miscellaneous pole hardware shall be **BAGGED IN BURLAP** for each pole. In addition, individual parts shall also be furnished as specified.

1.2 Materials

1.2.1 General

ALL STEEL STRAIN POLES PROVIDED FOR ANY INDIVIDUAL PROJECT SHALL BE FROM THE SAME MAUFACTURER.

Each Steel Strain Pole Assembly shall consist of:

1. A steel Shaft,
2. A steel Anchor Base,
3. Four steel Anchor Bolts with eight nuts,
4. A removable top plate which will bolt to the shaft with a ¼" J-Bolt and attached to a ½" bar that is welded inside the shaft,
5. Four removable anchor bolt Covers,
6. Two adjustable heavy duty Pole Clamps, and
7. Miscellaneous hardware as specified.

1.2.2 Pole Materials

1.2.2.1 Shaft

The design of the shaft will be based on a minimum mill certified 55,000 yield strength steel. The following steel may be used in the fabrication of the shaft: ASTM A570-50, ASTM A572-50, ASTM A572-60, ASTM A607-50, ASTM A607-55, ASTM A607-60, ASTM A595-A or ASTM A595-B.

Only one (1) longitudinal weld, and no transverse welds, shall be permitted.

After being formed and welded, the Shaft shall then be longitudinally cold-rolled with sufficient pressure to flatten the weld. Break formed, (multi-sided) poles shall have a minimum of eight (8) sides and a guaranteed mill certified minimum yield of 55,000 PSI.

The Shaft shall have a uniform taper in diameter from base to top of 0.14 inches per foot. The minimum base diameter and length shall be as specified in the Dimensions Chart.

A reinforced hand hole, complete with frame and cover with a minimum size of 4" x 6 1/2", shall be welded into the Shaft approximately 12" above the base plate at 0 degrees. The frame shall be tapped with a 1/2" - 13 UNC for a grounding bolt. Stainless-steel hardware shall be supplied.

A J-hook wire support shall be welded inside near the top of the Shaft.

Round holes shall be provided in EVERY POLE as follows:

- 3" diameter hole, at 6" on-center below pole TOP; at 0 degrees (above hand hole).
- 3" diameter hole, at 6" on-center below pole TOP; at 270 degrees (orientate counter-clockwise).
- 3" diameter hole, at 15 ¼" on-center above pole BOTTOM; at 90 degrees (orientate counter-clockwise).

The two (2) 3" upper holes are for installing weatherheads w/nipple and the lower 3" hole is to permit the installation of a pole mounted Controller Cabinet. A 3" threaded, half-blind coupling shall be FACTORY WELDED, to the pole surface and protrude ¼" in each hole. The entire pole coupling shall then be hot dipped galvanized.

1.2.2.2 Anchor Base and Flange Plates

The Anchor Base and flange plates shall be made from ASTM A36 steel.

The Anchor Base shall be square (with rounded corners), and shall be of the size and thickness specified in the DIMENSIONS TABLE.

The Anchor Base shall be provided with four (4) holes to accept Anchor Bolts. The size of the holes and the bolt circle shall be as specified in the DIMENSIONS TABLE.

Tapped holes shall be provided for attaching removable Anchor Bolt covers, which shall be provided with stainless steel hex-head bolts.

The Anchor Base shall telescope the Shaft, and shall be secured to the Shaft by two fillet welds. One weld shall be on the inside of the base at the end of the Shaft, and the other shall be on the outside at the top of the base. The welded connection shall develop the full strength of the adjacent cross-section to resist bending action.

1.2.2.3 Anchor Bolts and Nuts

Anchor Bolts shall be steel rods of ASTM A-36 M-55, modified to have a minimum yield point of 55,000 PSI.

Four (4) Anchor Bolts shall be supplied with each pole. The Anchor Bolt size shall be specified in the Dimensions Chart.

Each Anchor Bolt shall be threaded at the top for 10 inches, and shall have a 6 inch L-bend at the bottom, or a bearing plate as specified on larger pole sizes.

A total of eight nuts and eight flat washers shall be supplied and installed for each pole. Nuts shall be ASTM 563 Grade A. The two nuts per bolt may be either:

- two hex nuts (preferred), or
- one hex nut, and one square nut (acceptable).

Note: All other bolts shall be ASTM A325 or A307, (threaded per UNC series).

1.2.2.4 Pole Cap or Top Plate

Each pole shall be supplied with a Cap or top which shall be made from 7 GA. Galvanized steel or from cast aluminum, ASTM B-108; Alloy 356.OT6.

The Pole Cap shall be of a size greater than the pole top diameter and designed to prevent water from entering the top of the pole.

1.2.2.5 Bolt Cover

With each Pole there shall be supplied four (4) removable bolt covers capable of hiding the installed Anchor Bolts and the top nut. The covers shall have a clean-lined modern appearance. They shall attach to the pole with stainless-steel hex-head bolts. Acorn nuts are also acceptable.

1.2.2.6 Pole Clamp

With each Strain Pole there shall be supplied two adjustable Span Wire Clamps. Each span wire clamp shall be constructed of 1/4" x 3" steel minimum, complete with two 7/8" x 4" stud bolts including two lock washers and two hex nuts per stud bolt. Each span wire clamp shall also include a clevis complete with a 7/8" x 3" bolt with one lock washer and one hex nut.

1.2.2.7 Pole Plugs

Plugs/Caps, either galvanized or stainless, shall be supplied for all holes in the steel pole. Plugs/Caps shall be installed in all un-used holes in the steel pole in a construction project.

1.2.3 Dimensions

Strain Poles shall be supplied on a per EACH basis, with dimensions in accordance with the following table:

DIMENSIONS TABLE

GALVANIZED STEEL SHAFT			GALVANIZED STEEL PLATE BASE			ANCHOR BOLTS			
Type	Diameter at Base	Length	Mfr's Standard Gauge	Plate Size	Plate Thickness	Bolt Circle	Bolt Hole Diameter	Diameter X Pole Total Length	Design Load @ Yield
13" X 26'	13"	26'	#3 gauge	19" square	2"	18"	2 3/8"	2"X90" (including L-bend)	5,200 lb.
13" X 28'	13"	28'	#3 gauge	19" square	2"	18"	2 3/8"	2"X90" (including L-bend)	5,200 lb.
13" X 32'	13"	32'	#0 gauge	19" square	2"	18"	2 3/8"	2"X90" (including L-bend)	5,800 lb.

1.2.4 Other Materials

Other materials shall meet the following requirements:

1.2.4.1 Concrete

The concrete used in the pole base, shall conform to the requirements of DOT STANDARD SPECIFICATIONS, Section 701, 702, 703, and 704. The concrete shall be CLASS X, with "WATER-REDUCER ADMIXTURE", installed in ONE MONOLITHIC POUR, with VIBRATION.

1.2.4.2 Reinforcing Steel

Steel reinforcement shall conform to the requirements of DOT STANDARD SPECIFICATIONS, Section 703.2.1, which is amended to include the following:

"All references to AASHTO M 31 or ASTM A 615 are hereby deleted and replaced by ASTM A 706 with a single minimum yield strength level of 60,000 psi, designated as Grade 60."

The bars shall be of the size and type shown on the Design Details or in the Standards.

1.2.4.3 Conduit Elbow

Conduit Elbows shall be in accordance with FURNISH AND INSTALL ELECTRICAL CONDUIT. Conduit Elbows in pole bases shall be PVC, of the size and type shown on the Plans. As a minimum, THERE SHALL BE AT LEAST 1 CONDUIT ELBOW (2 INCH PVC ELBOW) IN EACH POLE BASE.

1.2.4.4 Ground Rod

Ground rods shall be 5/8 inch by 8 feet (minimum) Copper-Clad. A No. 6 AWG bare, stranded copper wire shall be used in the ground connection. EACH STRAIN POLE SHALL HAVE 1 GROUND ROD.

1.2.4.5 Pole Plugs

Plugs/Caps, either galvanized or stainless, shall be installed in all un-used holes in steel pole.

1.2.4.6 Miscellaneous

All other hardware or components shall be made of a non-corrosive material, or be of the same material as the item being installed.

1.2.5 **Galvanizing**

The following shall be hot-dipped galvanized to ASTM A-123:

Shaft, Anchor Base, nuts, and hand hole frame and cover, the top 12 inches of the Anchor Bolts, Pole Clamp, and all other steel or iron parts.

1.2.6 **Powder Coating Over Base (Optional)**

Powder Coating over base shall be an option. The finish color shall be specified at the time of ordering. The following shall be powder coated: Shaft, anchor base, nuts, hand hole frame and cover, the top 12 inches of the anchor bolts, pole clamp, and all other steel or iron parts.

1.2.7 **Powder Coating Over Galvanized (Optional)**

Powder Coating over galvanized shall be an option. The finish color shall be specified at the time of ordering. The following shall be powder coated after they have been hot-dipped galvanized: Shaft, anchor base, nuts, hand hole frame and cover, the top 12 inches of the anchor bolts, pole clamp, and all other steel or iron parts.

1.2.8 **Pole Labeling**

Every Pole shall be easily read and prominently labeled on the outside edge of the base plate. The method used shall be that the pole description is inscribed with 'WELDING-BEAD', neatly hand-written, in 1-1/2 to 2 inch high letters. The legend used shall be one of the following:

13" X 26'

13" X 28'

13" X 32'

Note: Codes shall not be acceptable for pole size labeling. The labeling shall be applied prior to galvanizing.

Weather proof Color Coding shall be included on each pole to facilitate ease of selection and identification. The color coding shall be as follows:

13" x 26'	Bright Green
13" x 28'	Bright Red
13" x 32'	Bright Yellow

1.2.9 Design and Drawings

The Vendor shall furnish pole design details and shop-drawings in sufficient detail for complete evaluation and comparison with these Specifications. Any exceptions to these Specifications must be stated in writing.

1.2.10 Certification

CATALOG CUTS ARE REQUIRED

The Vendor shall also provide a certification from the Manufacturer, that all Strain Poles provided under this item shall have guaranteed minimum yield strength of 55,000 P.S.I.

1.2.11 Quality Control, Testing, Certification

Where required, materials must be in full compliance with AASHTO and ASTM in effect on the date of advertisement.

Performance Testing - The Department reserves the right to receive on demand a test report from an independent laboratory certifying that the equipment furnished meets these specifications, at no costs to the Department. The bidder shall also provide a certification from the manufacturer that all strain poles shall have a guaranteed minimum yield strength, (mill certified), of 55,000 PSI.

Rejection - The Department reserves the right to reject an entire shipment of poles covered by this specification and project, if ten percent (10%) or more are found to be defective within a 30 day period following receipt of materials.

1.2.12 Packaging

For Anchor Bolts – To preserve the threads, to help improve stock yard inventory procedures, and to enhance loading/unloading of the shipment, the Anchor Bolts (for either a pole shipment or as spares) shall be packaged and mounted on a pallet with four anchor bolts across and four levels high. Each layer should lay opposite so that the six inch bend protects the threaded end of the next level.

For Pole Hardware – To help improve stock yard inventory procedures, and to make outside storage possible, all anchor bolt hardware and all pole hardware for each pole shall be included in ONE BURLAP BAG. No cardboard boxes shall be permitted. The bag shall contain the nuts, washers, pole cap, pole covers, pole clamps, pole plugs and all associated hardware shall be placed inside each steel pole.

If necessary, the bag shall be labeled by pole size if smaller clamps are needed for the 26' poles.

1.2.13 Delivery

Shipment for the poles shall be made via open-bed truck to facilitate unloading.

Delivery shall be made to the SCDOT Supply Depot, 1418 Shop Road, Columbia, SC or specified equivalent or less distance. Notice shall be given to the supervisor at the supply depot (803-737-6631) at least two working days in advance, as to the date of shipment, and expected delivery date to the supply depot. Separate line items are available for delivery of equipment beyond the distance of the SCDOT Supply Depot according to the **MOBILIZATION OF MATERIALS** specification included in the Steel Strain Pole solicitation (SCDOT Supply Depot being the location of material when provided by a manufacturer).

Steel strain poles shall be delivered to a location specified at the time of ordering. Delivery time shall be no later than 30 calendar days. Expedited delivery time shall be no later than 15 calendar days. An additional line item is included for expedited delivery.

Any material received that does not meet these specifications will be returned at the expense of the vendor or manufacturer.

1.2.14 Manufacturer/Supplier

The pole manufacturer/supplier must have a minimum of ten (10) years continuous experience in the manufacture of strain poles and shall have a full time registered professional engineer on staff.

1.2.15 Warranty

The Manufacturer or Vendor shall warrant the poles and all associated hardware to be free from defects in material and workmanship for a period of two (2) years from date of shipment. Any defects within this period shall be repaired or replaced by the Manufacturer or Vendor, at total cost to the Manufacturer or Vendor, including labor, parts and transportation.

1.3 Measurement

Furnishing Steel Strain Poles, will be measured by each, of the size(s) specified, anchor bolts, nut covers, pole cap, reinforcing steel, ground rod, ground wire, and all miscellaneous hardware as required.

1.4 Payment

Furnishing Steel Strain Poles, accepted, and measured as above, will be paid for at the contract unit price bid for:

FURNISH 13" X 26' STEEL STRAIN POLE	EA
FURNISH 13" X 26' STEEL STRAIN POLE (POWDER COATED OVER BASE)	EA
FURNISH 13" X 26' STEEL STRAIN POLE (POWDER COATED OVER GALVANIZED)	EA
FURNISH 13" X 28' STEEL STRAIN POLE	EA
FURNISH 13" X 28' STEEL STRAIN POLE (POWDER COATED OVER BASE)	EA
FURNISH 13" X 28' STEEL STRAIN POLE (POWDER COATED OVER GALVANIZED)	EA
FURNISH 13" X 32' STEEL STRAIN POLE	EA
FURNISH 13" X 32' STEEL STRAIN POLE (POWDER COATED OVER BASE)	EA
FURNISH 13" X 32' STEEL STRAIN POLE (POWDER COATED OVER GALVANIZED)	EA

M688.6 FURNISH CONCRETE STRAIN POLE

1.1 Description

This specification describes requirements for furnishing pre-stressed Concrete Strain Poles, of the sizes specified. These poles shall be of the type intended for direct embedding, with the hole back filled with concrete.

The following covers the design and fabrication of pre-stressed concrete strain poles, to be used for supporting steel cable suspended traffic signals or supporting lane control signs.

1.2 Materials

1.2.1 General

ALL CONCRETE STRAIN POLES PROVIDED FOR ANY INDIVIDUAL PROJECT SHALL BE FROM THE SAME MANUFACTURER.

Each Strain Pole assembly shall consist of:

1. A round pre-stressed hollow concrete shaft,
2. A pole cap, and
3. Miscellaneous hardware as specified.

Assumptions, designs and the poles shall meet or exceed the specifications stated in the publication "American Association of State Highway and Transportation Officials" (AASHTO); "Standard Specifications For Structural Supports For Highway Signs, Luminaires And Traffic Signals" and in particular, Section 7 "Pre-Stressed Concrete Design", 5th Edition, 2009. Stress in concrete due to pre-stressing shall be within the limits stated in the AASHTO Standard. Loss of pre-stress shall be calculated using AASHTO methods. Further, the manufacturer shall provide documentation showing the permeability/water-absorption of their product. Other procedures shall be according to the American Concrete Institute (ACI).

Poles shall be designed and constructed so that all wiring and grounding facilities are concealed within the hollow poles. All hand holes, wire inlets/outlets, inserts for pole steps, through bolt holes and the ground wire shall be cast into the pole during the manufacturing process. **NO FACTORY NOR FIELD DRILLING SHALL BE ALLOWED AFTER THE POLES HAVE BEEN STRIPPED FROM THEIR MOLDS.**

Poles shall be designed in accordance with the following requirements, to provide the Mandatory Ultimate Ground Line Moment and with the cable attachment heights stated below. As given, the design shall assume:

OVERALL POLE LENGTH	EMBEDMENT (below ground line)
35 feet	8 feet
40 feet	10 feet
45 feet	11 feet

The *Defined Attachment Height* = Overall Pole Length – Embedment. The design shall assume a worst case strain (pull) of 22,200 Newtons (5000 pounds force) applied at the top of the pole (the design Defined Attachment Height).

SCDOT design method. A worst case application of AASHTO and ACI “Ultimate Strength Design” has been used. M is moment, T is torsion, U is ultimate.

The formula used: $(1.25 * M / \phi M_u) + (1.25 * T / \phi T_u)^2 \leq 1.0$. The contribution of torsion was neglected. A ϕ of 0.90 was used. Substituting gives $M_u > (1.25 / 0.9) * M$ or $M_u > 1.39 M$. We increased the 1.39 multiplier by 7 percent, to allow for torsion, fatigue and possible accidental vehicle damage.

Design Formula: $M_u > 1.5 M$

1.2.2 Pole Materials

1.2.2.1 Concrete

The concrete mix shall be designed to achieve a minimum twenty-eight (28) day compressive strength (f'c) of 58,650 kPa (8,500 psi). Cement shall conform to the latest requirement of Type I or Type III Portland cement in accordance with ASTM C-150. The maximum size aggregate may be is 19 mm. (3/4 in.) or 3/4's of the clear spacing between the main reinforcing steel and the surface of the pole. Any water reducers, retarders or accelerating admixture used shall conform to ASTM C-494. The water used shall be free from foreign materials in amounts harmful to concrete or embedded steel. The compressive strength at release of pre-stress (f'ci) shall be 31,050 kPa (4,500 psi).

1.2.2.2 Reinforcing Steel

NO deformed steel reinforcement (ASTM A-615) shall be used in the manufacturing process.

1.2.2.3 Pre-stressing Steel

Pre-stressing steel stranded rope cable, which shall conform to uncoated 12.7 mm (0.5 inch), 7 wire, stress relieved strand (including low relaxation) of 1,201,500 Newtons (270,000 pound strain) grade, ASTM A-416. The minimum number of strands shall be eight (8) strands.

1.2.2.4 Spiral Reinforcement

Steel wire spiral reinforcement shall conform to ASTM A-82 and shall be of minimum diameter 0.150 inch. The pitch of the spiral reinforcement shall be on 2 inch centers for the first and last 3 feet of the pole, and 6.5 inch centers for the remaining portion of the pole. These requirements are more stringent than AASHTO.

1.2.2.5 Hardware

All structural steel shall conform to ASTM A-36 and be hot-dip galvanized per ASTM A-123. Hand hole frames and covers and all inserts shall be zinc allow AC41A, ASTM B-240. All bolts, nuts, washers and other fasteners shall be stainless steel or be hot-dip galvanized per ASTM A-153.

1.2.3 Manufacturing

All manufacturing tolerances, details of reinforcement and finishes shall be in accordance with the "Guide Specification For Pre-Stressed Concrete Poles", as published in the May-June 1982 issue of the "Journal Of The Pre-Stressed Concrete Institute".

All poles shall be pre-stressed and be manufactured by the centrifugal spinning process using a mold. The purpose of this requirement is to insure a minimum twenty-eight (28) day compressive strength of 8,500 psi, and to provide the densest possible surface finish.

Forms shall be designed to provide a continuous outside taper of 0.180 inches per foot of length. Forms shall also provide a minimum of 1 inch of concrete cover over the pre-stressing strands.

Poles shall have a smooth, natural form finish, concrete soft gray in color (no dyes or stains).

Poles shall be round in cross section, with a hollow center and shall be of one piece construction.

All excess concrete shall be removed from inside of pole before delivery.

Poles shall not have any exposed steel at either top or the butt end. Steel strands, both top and butt end, shall be burned back a minimum of 0.75 inch and the resulting hole shall be completely sealed with epoxy.

Pole bottom ends shall be plugged with 12 inches of concrete at the butt end, which shall also have a 2 inch diameter drain hole through that plug.

1.2.4 Pole Features

Contact the Traffic Signal & Systems Engineer at (803) 737-1050 for: "Standard Drawing 675-115-02" for the height and compass orientation of pole features; and "Typical Concrete Pole Orientation" for intended usage.

Each pole shall include the features listed below.

1.2.4.1 Pole Cap

Each pole shall be supplied with a pole cap or top, which shall be made of plate aluminum. (Galvanized steel is NOT acceptable.)

1.2.4.2 Wire Support

A wire support consisting of a diametric reinforcing bar shall be cast inside the pole about 6 inches from the top. This bar can also be used to anchor the pole cap if necessary.

1.2.4.3 Upper Hand hole

A reinforced hand hole frame, complete with flush cover, with a minimum size of 3.5 x 8 inches, shall be cast into pole approximately 1'-2" from the top of pole at 270°. (Orientate counter-clockwise)

1.2.4.4 Couplings

For weather head installation and entrance of the electrical cables, two (2) 2 inch I.D. conduit couplings shall be cast into the pole at 0° and 90° (orientate counter-clockwise) approximately 1'-2" from the top of pole and one (1) 2 inch I.D. conduit coupling 2'-10" from the top of the pole at 0°.

1.2.4.5 Holes

Through-holes, for attaching steel span cable using appropriate through-bolt hardware, shall be at 0°, 90°, 180°, and 270°. The upper holes should be approximately 1'-10" from the top of pole and the lower holes should be approximately 2'-4" from the top of the pole. **NO PVC** is required in holes so that each level of span wire through bolt hardware can be used in multiple directions.

1.2.4.6 Grounding

A No. 4 AWG stranded copper ground wire shall be cast into each pole and be attached to the pre-stressed steel by bonding connectors. The embedded ground wire shall be terminated near the top of the pole and at a point near the bottom, approximately 9 inches below the ground line. Both terminations shall be made to a "copper tank ground" which provides a 0.5 inch tapped insert on the pole face for grounding attachment to spans wires at the top and to the driven ground rod at the base.

1.2.4.7 Pedestrian Features

For possible pedestrian signal head assembly, each pole shall have four (4) 1 inch holes for wiring the signals that will be banded onto the pole at a height 10 feet above the ground line at 0°, 90°, 180°, and 270°.

For possible pedestrian push buttons, each pole shall have four (4) 1 inch holes for wiring a push button that will be banded onto the pole at a height 3'- 6 inches above the ground line at 0°, 90°, 180°, and 270°.

1.2.4.8 Pole Labeling

Every pole shall have an embedded "Builders Plate" (name plate) of brass or aluminum with raised or stamped letters stating the manufacturer, the date of manufacture, job identification, the length and diameter of the pole and the ultimate ground line moment capacity. The name plate shall be cast into the outside pole wall about 5 feet above the ground line.

1.2.4.9 Routhing Holes

A 1.5 inch "CANT" hole, completely through the pole and lined with PVC conduit shall be cast into each pole at a height 4 feet above ground line. The purpose shall be to permit inserting a pry-bar to turn the pole for proper orientation with the intersection.

There shall also be a Pick-Up point hole at the defined distances from the top of the pole found on the "Concrete Pole Openings, Thru-Bolts & Couplings".

1.2.4.10 Lower Hand Hole

The compass location of the hand hole defines the zero (0) degree point. Each pole for traffic signal support shall have a reinforced hand hole frame, complete with flush cover, with a minimum size of 3.5 x 8.5 inches, shall be cast into the pole approximately 1'- 6 inches above the ground line.

1.2.4.11 Pole Mounted Cabinet (all poles)

For possible controller cabinet installation, two (2) 3 inch I.D. conduit couplings shall be cast into the pole at 90° and 270° approximately 1'-6 inch from the ground line. **(Note: These couplings flank the lower hand hole)**

1.2.4.12 Underground Conduit Entrance

In each signal pole, there shall be cast in two (2) rectangular underground cable entrance openings (conduit entry hole) minimum size of 4 x 10 inches located approximately 1' – 6 inch below the ground line, just above embedding concrete at 0° and 270 degrees.

1.2.4.13 Pull Rope/Wire

The manufacturer shall furnish inside each pole a nylon or polypropylene rope or stainless steel wire so electrical wires may be pulled in installed pole. The rope or wire shall extend from the conduit opening near the base to the top of the pole.

1.2.4.14 Miscellaneous

Provisions shall be furnished for any other electrical or mechanical components not specifically stated, but required to complete the project as shown on the plans.

1.2.5 Other Materials

Other materials shall meet the following requirements:

1.2.5.1 Concrete

The concrete used to embed the pole shall conform to the requirements of SCDOT Standard Specifications, Sections 701, 702, 703 and 704. The concrete shall be SCDOT Class A (3,000 psi @ 28 days) installed in one monolithic pour with vibration.

1.2.5.2 Conduit Elbow

Conduit elbows shall be in accordance with furnish and install electrical conduit. Conduit elbows in pole bases shall be PVC of the size and type shown on the plans. If no other conduit is shown as a minimum, there shall be at least one (1) 2 inch PVC conduit elbow placed in each pole base.

1.2.5.3 Ground Rod

Ground rod(s) shall be 16 mm by 2.4 meters (5/8 inch by 8 feet) (minimum) copper clad. A No. 6 AWG bare stranded copper wire shall be used in the ground connection. **EACH STRAIN POLE SHALL HAVE AT LEAST ONE (1) GROUND ROD.**

1.2.5.4 Miscellaneous

All other hardware or components shall be made of a non-corrosive material or be of the same material as the item being installed.

1.2.5.5 Reinforcing Steel

Not usually needed for a concrete pole.

1.2.6 Design and Drawings

Prior to being approved for fabrication, the Vendor shall furnish from the manufacturer to the Engineer, complete stress computations, calculations, pole design details and design drawings in sufficient detail for complete evaluation and comparison with these Specifications. These submittals shall

indicate the dimensions and shape of all individual structural and electrical features, their relative location on each pole and their relationship with each other. Drawings shall be made as close to scale as possible and with all details large enough to be self-explanatory. Any exceptions to these Specifications must be stated in writing. When computer programs have been used during the design process, the printouts of the programs or a copy thereof shall be provided to the engineer.

1.2.7 Certification

CATALOG CUTS ARE REQUIRED

The Vendor or Manufacturer shall provide documentation stating the permeability and/or water absorption of their concrete pole.

The Vendor shall provide a written certification from the intended manufacturer that all components of strain poles provided under this item have been designed and manufactured in complete accordance with these specifications and the approved design drawings, including the strength of the concrete. The certification letter shall be signed by an officer of the company.

Poles must be manufactured within the United States at a facility solely owned by a company incorporated in the United States. **The manufacturer must have a minimum of ten (10) years experience in the design and production of centrifugally spun concrete poles shall have a full time registered professional engineer on staff.** Steel used shall comply with current Federal laws limiting foreign steel.

1.2.8 Quality Control, Testing, Certification

Where required, materials must be in full compliance with AASHTO and ASTM in effect on the date of advertisement.

By furnishing poles for this project, the manufacturer implicitly grants the right of entry and inspection to the Engineer (or designated representative) of SCDOT. If requested, each of the component materials involved in the production of these poles must be sampled, tested and approved by the SCDOT Materials Laboratory prior to the start of production. In addition the total production process, including curing, shall be subject to inspection and approval.

The Department, at the discretion of the Engineer, may direct that one (or more) randomly chosen poles shall be shipped directly to a testing facility other than the depot. This may be one of the SCDOT Materials Laboratories or an independent testing facility. There, the pole may be tested to destruction. This "test pole" shall be paid for at the contract unit price.

The Vendor shall furnish a Certification from the Manufacturer or Vendor, that the Steel Cable has been tested to meet or exceed the required tensile strength.

1.2.9 Delivery

Shipment for the poles shall be made via open-bed truck to facilitate unloading.

Delivery shall be made to the SCDOT Supply Depot, 1418 Shop Road, Columbia, SC or specified equivalent or less distance. Notice shall be given to the supervisor at the supply depot (803-737-6631) at least two working days in advance, as to the date of shipment, and expected delivery date to the supply depot. Separate line items are available for delivery of equipment beyond the distance of the SCDOT Supply Depot according to **MOBILIZATION OF MATERIALS** specification (SCDOT Supply Depot being the location of material when provided by a manufacturer).

Concrete strain poles shall be delivered to a location specified at the time of ordering. Delivery time shall be no later than 30 calendar days. Expedited delivery time shall be no later than 15 calendar days. An additional line item is included for expedited delivery.

Any material received that does not meet these specifications will be returned at the expense of the vendor or manufacturer.

1.2.10 Manufacturer/Supplier

Poles must be manufactured within the United States at a facility solely owned by a company incorporated in the United States. **The manufacturer/supplier must have a minimum of ten (10) years continuous experience in the design and production of centrifugally spun concrete poles and shall have a full time registered professional engineer on staff.** Steel used shall comply with current Federal laws limiting foreign steel.

1.2.11 Warranty

The Manufacturer or Vendor shall warrant the poles and all associated hardware to be free from defects in material and workmanship for a period of two (2) years from date of shipment. Any defects within this period shall be repaired or replaced by the Manufacturer or Vendor, at total cost to the Manufacturer or Vendor, including labor, parts and transportation.

1.3 Measurement

Furnishing Concrete Strain Poles will be measured by EACH of the length specified. This shall include pole cap and all miscellaneous hardware as required.

1.4 Payment

Furnishing Concrete Strain Poles accepted and measured as above, will be paid for at the contract unit price.

FURNISH 35' CONCRETE STRAIN POLE	EA
FURNISH 40' CONCRETE STRAIN POLE	EA
FURNISH 45' CONCRETE STRAIN POLE	EA

M688.7 FURNISH CONTROLLER AND 332/336 CABINET

1.1 Description

This specification describes requirements for furnishing Model 2070L Standard, digital, solid-state, micro-processor based, keyboard (push-button) programmable, Master/Local Controllers in: (1) POLE-, or (2) BASE- MOUNTED 332 or 336 Cabinets. This item shall include all electrical accessories and other items specified.

The phasing of the Controller and Cabinet shall be factory wired or wired by the CONTRACTOR or Manufacturer's Representative, to match (at each intersection) the Phasing Diagram, the Sequence of Operation form, or the Plans.

1.2 Materials

1.2.1 General

The equipment to be furnished shall be in accordance with CALTRANS *Transportation Electrical Equipment Specifications* (TEES), dated July 21, 2008 except as required herein.

Further, the equipment shall meet the special Department requirements, as stated in the following Specifications. In case of conflict, the Department Specifications shall govern.

1.2.2 Special Provisions

In addition to meeting the CALTRANS specifications as stated in section 1.2.1, all equipment shall also meet the following:

- Nylon card-guides shall be integrated into the cabinet assemblies where all Load Switch, Flasher and Input File Hardware may be installed. The card guide slots shall be of sufficient depth to support pluggable devices when they are not fully inserted into the electrical receptacles, and the installation or removal of pluggable devices shall not require excessive force.
- Raise AC Service terminal block to a minimum of 6" from base of the rack-supports in all Cabinet Assemblies.
- Appropriate Red, Yellow or Green color-coding shall be used for all Load Switch input and Load Switch output wiring within the Output and Auxiliary Output Files.
- Install an aluminum plate for reinforcement of the pole-mounting brackets. This plate shall be installed inside the 336S Cabinet Assembly and shall utilize threaded PEM nuts or self-clinching fasteners for simple installation and removal of exterior pole-mount bracket bolts without the use of any tool, inside the Cabinet Assembly.
- Install (4) support braces for the rack assembly. Braces shall be welded, with a continuous seam and (2) shall be installed on each side, directly under the rack assembly uprights.
- To prevent accidental, electrical contact between the Cabinet Assembly and Conflict Monitor Unit, the entire side panel within the output file that is directly adjacent to the solder-side of the Conflict Monitor Unit shall be insulated with non-conductive sheeting, including covering screw heads, rivets, etc. This sheeting shall not degrade over time and shall remain attached to the output file throughout the life of the Cabinet Assembly. This sheeting shall be of minimal thickness as to not impede the insertion and/or removal of the Conflict Monitor Unit.

- Red enable board shall implement individual, 2-position dipswitches allowing any unused red channel to be tied to AC+.
- The Red Enable board shall be easily removable and replaceable from the outside of the Output File Assembly. Removal and replacement shall not require the Output File Assembly to be opened. The design shall be such that the board can be easily unplugged and replaced. During normal operation the board shall be secured to the Output File Assembly.
- The Output File Assembly shall implement a hinged, clear, polycarbonate cover to protect the Red Enable Board during normal operation. This cover shall be hinged on the left or right side. When closed, the side opposite the hinge shall be secured to the Output File Assembly without the use of any hardware or tool. When fully opened, the cover shall not inhibit the removal, replacement or configuration of the Red Enable board. Removal/replacement of the Red Enable Board shall not require the removal of the protective cover.
- The Power Supply furnished in all 332A and 336S Cabinet Assemblies shall be the EDI 206S Switching Power Supply, or approved equivalent.
- The 206S Power supply in all Cabinet Assemblies shall be provided with a device that would prevent the power supply from being removed unintentionally. This device must be strong enough to support the weight of the power supply and shall be accessible from the FRONT of the Cabinet Assembly. The insertion or removal of the 206S Power Supply and security device shall not require the use of any tool. The shipping wing nut must be removed.
- All Cabinet Assemblies shall have BOTH doors ventilated and are to include disposable filters that are secured in place, yet easily removed or re-installed for replacement.
- Twisted-pair communication will not be used for any new cabinet installations, therefore an EDCO PC642 surge protection device and applicable 170-style cabling will not be required for any Cabinet Assemblies.
- Front and rear doors of all cabinet assemblies shall implement a #3 Corbin Locking assembly. Two (2) BRASS keys are to be included with each Cabinet Assembly.
- The front and rear door locks for all Cabinet Assemblies shall have a minimum of 1 mm (0.03937") clearance between the edge of each side of the lock bolt and the cabinet's latch cam assembly.
- Front and rear door handles for all cabinet assemblies shall turn away from the door lock/key to open the cabinet door.
- Furnish 2 sets of non-fading cabinet diagrams and schematics that are to be placed in a clear, sealable, water tight, plastic bag and stored within the front-door-mounted laptop shelf/storage compartment. See Section 3.1.3 "Laptop Shelf" for additional requirements.
- The Flash Sense/Stop Time terminations in the Input File Assembly shall be wired such that a DC Isolator will not be required for implementation of these functions by the Conflict Monitor Unit.
- Furnish (2) Model 242 DC Isolators with all 332A and 336S Cabinet assemblies. These items are to be installed within the cabinet input file, in the pedestrian input slots.
- Furnish (8) Loop Detectors with all 332A Cabinet Assemblies. These are to be installed in the first (8) slots of the upper input file assembly. See section 11.1 for LCD Detector requirements.
- Furnish (4) Loop Detectors with all 336S Cabinet Assemblies. These are to be installed in the first (4) slots of the input file assembly. See section 11.1 for LCD Detector requirements.
- Furnish (12) Model 200 Load Switches with all 332A Cabinet Assemblies. These are to be installed in the following output file channels: 1, 2, 4, 5, 6, 8, 13, 14, 15, 16, 17, 18. See section 7.1 for Load Switch requirements.
- Furnish (8) Model 200 Load Switches with all 336S Cabinet Assemblies. These are to be installed in the following output file channels: 2, 4, 6, 8, 13, 14, 15, 16. See section 7.1 for Load Switch requirements.

- Furnish (2) Model 204 Flashers with all 332A and 336S Cabinet Assemblies. These are to be installed in the flasher slots within the PDA. See section 8.1 for Flasher requirements.
- Load Switches and Flashers are to be secured within their respective slots for shipment, with 1/2" string-reinforced tape as a minimum.
- Furnish a Thermostat-controlled, dual-fan (100CFM minimum rating per fan) ventilation system in all 332 series Cabinet Assemblies.
- Furnish a Thermostat-controlled, single-fan (100CFM minimum rating) ventilation system in all 336S Cabinet Assemblies.
- Cabinet Thermostat to be factory-set to 90 degrees in all Cabinet Assemblies.
- Cabinet Thermostat and thermostat temperature setting shall be easily accessible and adjustable from the front of all 332A Cabinet Assemblies.
- Cabinet Thermostat and thermostat temperature settings shall be easily accessible and adjustable from the rear of all 336S cabinet assemblies.
- Cabinet Thermostat terminals shall be insulated to prevent accidental electric shock.
- Police panel door shall be insulated to prevent water from entering the cabinet assembly. The insulation material used and its ability to resist water-penetration shall not degrade over time.
- The Police panel assembly shall have a drain to prevent water from collecting within the assembly. Per CALTRANS, the drain shall be channeled to the outside of the cabinet. There shall be no additional holes within the police panel.
- The protective cover for the police panel key opening shall be snug with the police panel door and shall not move freely. However, this protective cover shall be easily opened without having to use any tool.
- Manual Control cord shall be permanently hard-wired into the Police panel assembly to prevent removal.
- Manual Cord shall be anchored to the inside of the cabinet chassis to prevent over-extension and/or damage to the Police Panel terminations when the cord is extended for use.
- For storage, the Manual Control cord should be fed into the cabinet assembly through a grommet opening at the top of the police panel. The location of the opening shall not allow water to enter the cabinet. Additionally, the cord shall be fed for storage into an area where there is no risk of 'snagging' the cable when it is extended for use. The storage area shall be sealed completely to prevent water from entering the cabinet when the police panel door is open.
- For additional security, a quick-connect/quick-disconnect, molex-style connector shall be used for the Police Panel wiring inside the Cabinet Assembly. This connector shall NOT be accessible from the Police Panel and should be easily accessible from inside the cabinet. The wiring of this connector shall be such that, when disconnected, the Manual Control Enable/Advance Enable function on the Police Panel, as well as the Interval Advance/Advance function on the manual cord cannot be applied to the Controller Unit.
- The Police panel shall be wired such that the Interval Advance/Advance function cannot be applied to the Controller Unit when the Manual/Auto switch is in the Auto position.
- The EDCO 1210 Surge Protection device (or approved equivalent) shall be a plug-in type installation, or shall be integrated onto a plug-in style panel for simple replacement. This assembly should be easily accessible within the Cabinet Assembly and shall be secured to prevent unintended removal. Removal/replacement of the surge suppressor or manufacturer-designed panel assembly shall not require the connection or disconnection of any wiring within the cabinet and shall be a simple procedure for one (1) technician.
- 332A and 336S Cabinet Assemblies shall NOT utilize a Mercury Contactor switch. A field-proven solid-state device (or approved equivalent) shall be used.
- All Vehicle and Pedestrian terminals on the Loop Input Termination Panel shall be clearly labeled with permanent screening, with the default CALTRANS phase assignment, in all 332A and 336S Cabinet Assemblies.

- The 332A Cabinet Assembly shall include additional terminations for Pedestrian Pushbutton inputs. These are to be wired in parallel with the standard input file terminations and surge protection. A Minimum of 24 extra terminals (12-position, dual-bus terminal strip) shall be provided, allowing 16 additional termination points for 4 Pedestrian Phases. The remaining 8 termination points shall be for the shared or “common” input for the adjacent Pedestrian Phase terminations. This termination panel shall be easily accessible, clearly labeled with permanent screening and may be placed in any available space on the side panel containing the standard Loop and Pedestrian input terminations. The required configuration is shown here:

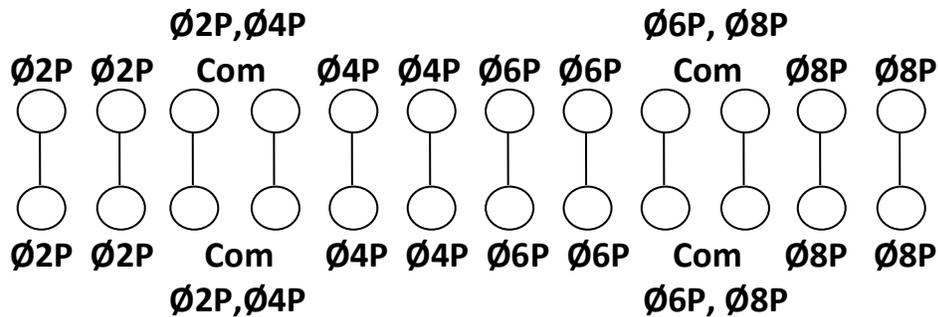

- The 332A and 336S Cabinet Assemblies shall have a ‘Detector Test Panel’ installed above the Controller Unit. The panel shall be installed within the rack assembly and will have (8) 3-position mini-toggle switches, symmetrically spaced and horizontally arranged for placing calls to the Controller Unit. 3-position On-Off-On switches shall activate inputs. Upward motion of the switch shall lock into place and shall place a vehicle call to the Controller Unit until the switch is manually returned to center position. The center position of the switch shall not inhibit normal detector operation. Downward motion of the switch shall place a momentary closure vehicle call and will allow the intersection to resume normal detector operation when released. This panel shall be clearly labeled with permanent screening beneath each switch. The labeling shall identify each detector switch and default phase assignment for phases 1 through 8. The panel should also be titled “Vehicle Call Panel” and shall include a legend for switch operation: “On, Auto, Pulse”. The panel shall be wired as follows:

336S Cabinet		332A cabinet	
Detector Switches	Terminal	Detector Switches	Terminal
Phase 1	I1-F	Phase 1	I1-W
Phase 2	I2-F	Phase 2	I4-W
Phase 3	I3-F	Phase 3	I5-W
Phase 4	I4-F	Phase 4	I8-W
Phase 5	I5-F	Phase 5	J1-W
Phase 6	I6-F	Phase 6	J4-W
Phase 7	I7-F	Phase 7	J5-W
Phase 8	I8-F	Phase 8	J8-W

1.2.3 Department Requirements

This section specifies Department specific requirements that extend or modify the CALTRANS Specification.

1.2.3.1 Cabinet Requirements

1.2.3.1.1 Mounting

Each 336S Cabinet shall be supplied with a removable base plate. Two (2) POLE mounting brackets shall be attached to each 336S cabinet. See Section 2.2 "Special Provisions" for additional requirements.

For 336S and 332A Cabinet Assemblies, the BASE mounting anchor-bolt pattern shall be as specified in the CALTRANS Specifications.

Aluminum Extender Base for 336S Cabinets - For 336S cabinets, an 8", aluminum extender base shall be available, manufactured in the shape and dimensions that match the shape, dimensions and bolt-pattern of a 336S Cabinet Assembly. This item shall be ordered at Department option. The appropriate stainless steel hardware (nuts, bolts and washers) shall be included with each extender base to sufficiently mount the base to the 336S Cabinet Assembly.

1.2.3.1.2 Police Button

Each 332A and 336S Cabinet Assembly shall be provided with a manual police push button on an insulated cord allowing the operator to stand a minimum of 6' from the Cabinet Assembly, permanently mounted in conjunction with a manual/auto switch. When placed in the manual position, Manual Control Enable or Advance Enable shall be applied to the Controller, and Minimum Recall shall be applied to all used phases. Activation of the push button shall apply the Interval Advance or Advance input to the Controller Unit. Manual advancement will be prohibited in the minimum green, and clearance timing intervals. See Section 2.2 "Special Provisions" for additional requirements.

1.2.3.1.3 Laptop Shelf

For all 332, 332A and 336S Cabinet Assemblies, a hinged, aluminum shelf and integrated storage compartment shall be installed on the front door, inside the Cabinet Assembly. To allow better ventilation throughout the cabinet and rack, a sliding shelf/drawer within the rack assembly will not be permitted. The shelf shall have a smooth, non-slip surface, sufficient for use as a writing platform and of sufficient size and rigidity to support a typical laptop computer when extended for use. This shelf shall have rounded or insulated edges that do not have the potential to physically harm the user. The shelf shall lock into place when folded for storage. Locking the shelf for storage and/or extending for use shall not require the use of any tool.

1.2.3.1.4 Loads

"Ped-Yellows" shall be provided with "dummy loads" consisting of load resistors rated at 5 watts minimum. The impedance of the load resistors shall be such that the Conflict Monitor Unit does NOT see a false indication for the yellow output of the pedestrian channels.

1.2.3.1.5 Lights

Each Cabinet shall include Two (2) LED Lighting Fixtures. One mounted inside the top-front portion of the Cabinet and one mounted inside the top-rear portion of the cabinet. Both shall illuminate equivocally to a 15-watt, cool white fluorescent light fixture and shall include an easily accessible on-off switch. Door-actuated switches shall be installed to turn on the cabinet lights when either the front or rear door are opened.

1.2.3.2 Surge Protection

1.2.3.2.1 General

Each 336S and 332A Cabinet shall be provided with devices to protect the control equipment from surges and over voltages. This shall include incoming power lines, the Input File, the Output File (load switch-packs), and communication lines. The surge protection for the Input File shall be in accordance with the assignment of the slots of a standard 336S Cabinet assembly. Surge protector termination panels shall be provided, attached to the Cabinet rack assembly. AC isolation terminals shall be on the same side of the Cabinet as the AC service inputs. DC terminals and loop detector terminals shall be installed on the opposite side of the Cabinet from the AC power lines, to reduce electromagnetic induction. The surge protector panels shall be designed to allow for adequate space for a wire connection and surge protector replacement. Surge protection shall be provided for the full capacity of the Cabinet Input File.

1.2.3.2.2 Intent of Surge Protection

It is the intent of the Department to require surge protection on each CALTRANS defined input; that is, full protection. For example, on the 336S Cabinet, Vehicle Loop Detector Surge Protection would be required on two (2) channels each, of Slots 1 to 8 of the Input File. In addition, on the remaining Slots 9 to 14, Pedestrian surge protection; plus Auxiliary (pre-emption) protection as defined.

On the 332A Cabinet, full protection is desired on both Input Files. For example, Vehicle Loop Detector Surge Protection would be required on two (2) channels each, of Slots 1 to 8 of BOTH INPUT FILES I AND J; together with pedestrian and auxiliary protection on both racks.

1.2.3.2.3 Mounting

For the 332A Cabinet, appropriate input surge protection shall be mounted on the INPUT TERMINATION PANEL. For the 336S Cabinet, appropriate input surge protection shall be mounted on a FOLD-DOWN TERMINATION PANEL on the rear of the cabinet assembly. This fold-down panel shall not obstruct the Output File Field wiring when in the closed position and shall utilize thumb-screws to secure the panel under normal operating conditions.

Under no circumstance (normal operation or short-circuit condition) shall the ampacity of the internal wiring and printed circuit board traces be less than the protecting threshold of circuit breakers and surge protectors provided.

1.2.3.2.4 Power Distribution Assembly

The Power Distribution Assembly of each Controller Cabinet shall include a lightning/surge/transient protection unit on the AC Service Input. It shall be capable of reducing the effect of lightning transient voltages applied to the AC line. The protector shall be a two-stage series/parallel device, and shall be an EDCO SHA-1210 (or approved equal). It shall have the following features and functions:

- Maximum AC line voltage: 140 VAC

- Twenty pulses of peak current, each of which will rise in 8 microseconds and fall in 20 microseconds to one-half the peak: 20,000 Amperes
- The protector shall be provided with the following terminals:
 - Main line (AC Line first stage terminal)
 - Main Neutral (AC Neutral input terminals)
 - Equipment Line Out (AC Line second stage output terminal, 10 Amps).
 - Equipment Neutral Out (Neutral terminal to protected equipment).
 - Ground (Earth connection)
- The Main AC line in and the Equipment Line out terminals shall be separated by a 200 Micro Henry (minimum) inductor rated to handle 10 Amp AC Service.
- The first stage clamp shall be between Main Line and Ground terminals.
- The second stage clamp shall be between Equipment Line Out and Equipment Neutral.
- The protector for the first and second stage clamp shall have a MOV or similar solid-state device rated at 20 KA; and be of a completely solid stage design (i.e. no gas discharge tubes allowed).
- The Main Neutral and Equipment Neutral Output shall be connected together internally, and shall have an MOV (or similar solid state device, or gas discharge tubes) rated at 20 KA between Main Neutral and Ground terminals.
- Peak clamp voltage: 250 Volts at 20 KA. (Voltage measured between Equipment Line Out and Equipment Neutral Out terminals. Current applied between Main Line and Ground Terminals with Ground and Main Neutral terminals externally tied together).
- Output voltage shall never exceed 280 volts.
- The Protector shall be epoxy-encapsulated in a flame retardant material.
- Continuous service current; 10 Amps at 120 VAC RMS.
- The Equipment Line Out shall provide power to the Type 170 Controller, and to the 24 V power supply.

1.2.3.2.5 Inductive Loop Detector Input

Each inductive loop detector input channel shall be protected by an external surge protection device which shall be an EDCO SRA-6LC (or approved equal) meeting or exceeding the following requirements:

- It shall be a three-terminal device, two of which shall be connected across the signal inputs of the detector. The third terminal shall be connected to chassis ground to protect against common mode damage.
- It shall instantly clamp differential mode surges (induced voltage across the loop detector input terminals) via a semiconductor array. The array shall be designed to appear as a very low capacitance to the detector.
- It shall clamp common mode surges (induced voltage between the loop leads and ground) via solid state clamping devices.

- It shall meet or exceed the following requirements:

Peak Surge Current (six times)	
Differential Mode	400 Amps (8x20 μ s)
Common Mode	1000 Amps (8x20 μ s)
Estimated Occurrences	500 @ 200 Amps
Response Time	40 ns
Input Capacitance	35 pf typical
Temperature	-40 degrees to +85 °C
Mounting	No. 10-32 x 3/8" bolt
Clamp Voltage	
@400 Amps Diff. Mode	30 volts max.
@1000 Amps Comm. Mode	30 volts max.

1.2.3.2.6 Signal Load Switches (Switch-Packs)

The outputs of each switch-pack in the output file shall be provided with a Metal Oxide Varistor (MOV), which is connected from the AC positive field terminal, to the chassis ground. The MOV shall be rated 150VAC, and shall be a V150LA20A.

1.2.3.2.7 Low Voltage DC Inputs

Each DC Input channel shall be protected by an external surge protection device, which shall be an EDCO SRA64-030N (or approved equal), that meets or exceeds the following:

- It shall be a five terminal device. Two terminals shall be connected to the line side of the low voltage pair, two terminals shall be connected to the Input File side, and the fifth terminal shall be connected to chassis ground.
- It shall meet the following minimum requirements:

Peak Surge Current	2000 Amps 8x20 μ s Wave-shape
Occurrences at Peak Current	100 typical
Response Time	5 to 30 nanoseconds
Shock	Withstands 10-foot drop on concrete
Voltage Clamp	30 v
Series Resistance	15 ohms each conductor
Temperature	-20 Degrees to +85 °C

1.2.3.2.8 Pre-Emption & 115 VAC Signaling Inputs

Each pre-emption or AC signaling input channel shall be protected by an external surge protection device, which shall be an EDCO SPA-60BS-2 (or approved equal), that meets or exceeds the following:

- It shall be a three terminal device.
- It shall meet the following minimum requirements:

Peak Surge Current	2000 Amps 8x20 μ s Wave-shape
Occurrences at Peak Current	25 minimum

Response Time	< 200 nanoseconds
Shock	Withstands 10-foot drop on concrete
Peak Surge Trip Point	< 890 V nominal
Temperature	-40 Degrees to +85 °C

1.2.4 Cabinet, Controller, and Equipment

1.2.4.1 Model 336S Cabinet Assembly (46" x 24" x 22")

The Model 336S Cabinet Assembly shall be as specified in the CALTRANS Specifications. The Cabinet shall be capable of side-pole mounting, as well as base mounting. See Section 2.2 "Special Provisions" for additional requirements.

The 336S Cabinet shall incorporate input surge protection mounted on a FOLD-DOWN TERMINATION PANEL at the rear of the Cabinet Assembly. This fold-down panel shall not obstruct the Output File Field wiring when in the closed position and shall utilize thumb-screws to secure the panel under normal operating conditions. The fold-down portion of this panel shall be easily accessible and shall be mounted to the rack assembly.

The 336S Cabinet shall NOT have an AUXILIARY OUTPUT FILE. Additionally, Auxiliary Output files will not be added to a 336S Cabinet Assembly, therefore the additional wiring necessary to add an Auxiliary Output file shall not be installed. All assemblies in the 336S Cabinets shall be installed in the upper most position so that free space at the bottom of the cabinet is maximized.

1.2.4.2 Model 332A Cabinet Assembly (66" x 24" x 30")

The Model 332A Cabinet Assembly shall be as specified in the CALTRANS Specifications. This Cabinet shall incorporate an INPUT TERMINATION PANEL. See Section 2.2 "Special Provisions" for additional Pedestrian Pushbutton Termination requirements. The Cabinet shall be base mounted.

The 332A Cabinet Assembly shall be configured for 8 vehicle phases, 4 pedestrian phases and shall include an AUXILIARY MODEL 420 OUTPUT FILE, for 6 overlap phases..

1.2.4.3 Model 332 Cabinet (66" x 24" x 30")

The Model 332 Cabinet shall be base mounted and shall contain a standard rack assembly for the future installation of various ITS components. The cabinet shall meet all aspects of the physical and structural requirements stated in Section 2.2 "Special Provisions".

The following shall be installed:

A 3-terminal, 50-Amp AC Service bus shall be installed as well as a Thermostat and dual-fan ventilation system with two (2) cabinet filters. Two (2) LED light fixtures with front and rear door-activated switches shall also be installed.

The thermostat, fans and lights shall be appropriately wired. The service side of the AC+ and AC Neutral wires for this equipment shall be neatly dressed and brought down the full length of the side-panel of the Cabinet Assembly for DOT personnel to terminate at a later time.

This Cabinet may be used by the Department for future projects such as ramp metering, sign control, speed detection, or freeway surveillance.

1.2.4.4 CONTROLLER UNIT

Furnish Model 2070L Controllers. Units shall conform to CALTRANS Transportation Electrical Equipment Specifications (TEES), dated July 21, 2008 except as required herein. Units shall also be approved as stated on the current SCDOT "Qualified Products List". Provide model 2070L Controllers composed of the unit chassis and at a minimum, the following modules, assemblies, and software:

- Model 2070-4B Power Supply Module, 3 AMP
- Model 2070-3B Front Panel Module
- Model 2070 1B CPU Module, single board
- Model 2070-2A Field I/O Module
- Model 2070-7A Asynchronous Serial Com Module
- Controller Software – Provide model 2070L with the software compatible with the controller. Both controller and software must be on the current SCDOT "Qualified Products List" at the time of the work order. The installed controller will be selected for particular work orders at the discretion of the Traffic Signals and Systems Engineer based on compatibility with the central software.

1.2.4.5 POWER DISTRIBUTION ASSEMBLY 2

The Power Distribution Assembly shall be as specified in the CALTRANS Specifications for Assembly 2, and modified as follows. The Assembly shall include an EDI Model 206S Switching Power Supply as stated in Section 1.2.2 "Special Provisions".

It shall include over-voltage protection as described in the paragraph "SURGE PROTECTION" (EDCO SHA-1210 or approved equivalent). See Section 1.2.2 "Special Provisions" for additional requirements.

1.2.4.6 MODEL 200 LOAD SWITCH

The Load Switch shall be a PDC MODEL SSS-87I/O LOAD SWITCH, meeting or exceeding the CALTRANS and Los Angeles County Specifications.

1.2.4.7 MODEL 204 FLASHER

The flasher module shall be a PDC MODEL SSF-88 FLASHER, meeting or exceeding the CALTRANS and Los Angeles County Specifications.

1.2.4.8 MODEL 2010 ECL-IP CONFLICT MONITOR - WITH ABSENCE OF RED MONITORING

The Conflict Monitor shall be an EDI Model 2010 ECL-IP Conflict Monitor.

The Conflict Monitor Unit shall contain a 10/100 Ethernet port on the front panel for the uploading of alarms and/or event logs with a standard laptop computer. This port shall also allow for future communication within an Ethernet-based infrastructure.

1.2.4.8.1 Red Monitor Harness

A connector and terminal assembly designated as P20 (Magnum P/N722120 or equivalent), for

monitoring the absence of red, shall be an integral part of the output file. The connector shall terminate, and be compatible with, the cable and connector of a Type 170 Conflict Monitor unit (CMU), capable of monitoring the absence of red.

The P20 cable shall be routed internally or between the rack assembly and cabinet wall. The cable shall be anchored to the front of the output file so that the Conflict Monitor Unit cannot be removed with the cable attached. The pin assignments of the P20 connector and terminal assembly shall be provided with the Cabinet plans. The P20 connection shall be physically "keyed" to prevent the cable from being installed incorrectly. The P20 cable shall be latched to both the conflict monitor and the red enable board.

1.2.4.8.2 Programming of Unused Red Channels

All Cabinet assemblies shall be provided with a means of applying AC+ to unused red channels by the configuration of dipswitches on the Red Enable board. The Red Enable board in all Cabinet Assemblies shall have full compatibility with model 210N, 2010ECL and 2010ECL-ip Conflict Monitor Units. See Section 1.2.2 "Special Provisions" for additional requirements.

1.2.4.9 MODEL 222 LOOP DETECTOR AMPLIFIERS

The Loop Detector Amplifier Unit shall be an EDI MODEL 222 (or equivalent) as specified in the CALTRANS Specifications. The detector shall be two (2) channels.

The Detector shall be on the CALTRANS QPL and SCDOT QPL listed and shall perform properly when installed in new or existing Cabinet Assemblies in South Carolina.

1.2.4.10 LCD ENHANCED/INTELLIGENT LOOP DETECTOR AMPLIFIER

The Loop Detector Amplifier Unit shall be an EDI Oracle or Reno A&E Model C Rack Mount Detector Amplifier or approved equivalent. The Detector shall perform properly when installed in new or existing Cabinet Assemblies in South Carolina.

1.2.4.11 MODEL 242 D.C. ISOLATOR

The D. C. Isolator unit shall be a MODEL 242 as specified in the CALTRANS Specifications.

1.2.4.12 MODEL 430 FLASH TRANSFER RELAY

The Flash Transfer Relay unit shall a MODEL 430 as specified in the CALTRANS Specifications.

1.2.4.13 AUTOMATIC TESTER (FOR 210N, 2010ECL, and 2010ECL-IP CONFLICT MONITORS)

This item shall be ordered at Department option.

This shall be a stand-alone portable "Tester", intended for use on a workbench. The Tester may utilize an IBM compatible computer for input/output. The Tester shall test Conflict Monitor displays; timing and voltage functions; input/output combinations for true or false conflicts. Any software shall be modular, menu driven, and offer "help" screens as well as having compatibility with SCDOT's Current

Windows Professional Software. A video "setup/usage" training tape shall be provided with each unit. All input/outputs shall be in plain English. It shall be possible to generate a hardcopy printout, or to store the results to a disk file. A "No Faults Detected" report shall be displayed as appropriate.

1.2.4.14 EXTERNAL FIBER OPTIC MODEM MODULE

This item shall be ordered at Department option. It will be used at 2070L Master and/or Local Controllers requiring Fiber Optic Communication within a Closed-Loop System.

The modem used for this contract shall be the Traffic Fiber Systems Model FO-512 Fiber Optic Data Link or approved equivalent. The modem shall be furnished with a power supply AND RS-232 cable.

The RS-232 cable used for this contract shall provide a fully functional, full-duplex communication link between a Serial Port on the 2070-7A Comm Module and the supplied Fiber Optic Modem. The cable shall be a minimum of 3' in length. The connectors shall include a protective shell and must utilize two (2) industry-standard thumb-screws to secure the cable in place at both ends without having to use any tool. The connector assembly shall also be manufactured in such a way that the connecting cable and connector are secured to prevent unintentional electrical and/or physical separation. The cable shall have connections with the proper gender on each end (without the use of gender adapters) and shall be clearly labeled.

1.2.4.15 MODEM – EXTERNAL DIAL-UP

This item shall be ordered at Department option. It will be used in either the Central Office, or at a Field Master or Local Intersection requiring dial-up access.

The dial-up modem used for this contract shall be the US Robotics V.92 External Modem. The modem shall be furnished with a power supply, telephone cable AND RS-232 cable.

The RS-232 cable used for this contract shall provide a fully functional, full-duplex communication link between a Serial Port on the 2070-7A Comm Module and a US Robotics V.92 External Modem for telecommunications. The cable shall be a minimum of 3' in length. The connectors shall include a protective shell and must utilize two (2) industry-standard thumb-screws to secure the cable in place at both ends without having to use any tool. The connector assembly shall also be manufactured in such a way that the connecting cable and connector are secured to prevent unintentional electrical and/or physical separation. The cable shall have connections with the proper gender on each end (without the use of gender adapters) and shall be clearly labeled.

1.2.4.16 CABINET ASSEMBLY DISPLAY UNIT

This item shall be ordered at Department option. It will be used by Technicians in SCDOT Signal Shops.

The unit required for this contract will be used by signal shop technicians during the set up and integration of 336S and 332A Cabinet Assemblies. Via permanent screening, the unit will display a mock-up of a quad intersection with left turns and shall implement appropriately arranged and colored AC-driven indications of all channels for eight (8) vehicle phases and four (4) pedestrian phases. The unit shall also have additional indications for six (6) auxiliary vehicle overlaps and four (4) pedestrian yellow channels. The display unit shall include a harness that is a minimum of 10' in length, Termination wires shall be red, yellow, and green color-coded and phase marked for all indications, as well as one (1) white, AC Neutral and one (1) green, Chassis Ground termination. All wires shall have #10 stud spade lugs

installed and shall be labeled by phase and color.

The display unit shall provide proper load to accurately simulate on-street, AC signal terminations for testing purposes within a signal shop environment. This unit shall be designed so that it can be placed on top of the Cabinet Assembly, or hung on the inside of the front door of any Cabinet Assembly supplied for this contract.

1.2.4.17 MODEL 206S POWER SUPPLY

This item shall be ordered at Department option. It will potentially be used to upgrade existing standard 206 Power Supply Units in the field.

The unit required for this contract shall be the EDI Model 206S Power Supply or approved equivalent. The Power Supply Unit shall incorporate switching design technologies as well as Power Factor Correction. See Section 1.2.2 "Special Provisions" for additional physical requirements.

1.2.4.18 SURGE PROTECTION FOR TWISTED-PAIR COMMUNICATION

Surge protection for twisted-pair communication shall be included in all 332A and 336S Cabinet Assemblies. The surge protection device shall be an EDCO PC-642C-30-X (or approved equal). See Section 1.2.3.2.7 for additional requirements.

Applicable 170-style cabling shall be included in all 332A and 336 S Cabinet Assemblies.

1.2.4.19 REPLACEMENT RED ENABLE BOARD FOR 332A AND 336S CABINET ASSEMBLIES

This item shall be ordered at Department option. It will potentially be used to replace damaged or malfunctioning Red Enable boards within 332A and 336S Cabinet Assemblies supplied for this contract. Items furnished shall be identical to the red enable boards furnished with the 332A and 336S Cabinet Assemblies for this contract.

See Section 1.2.2 "Special Provisions" for additional requirements.

1.2.4.20 REPLACEMENT #3 LOCK AND KEY SET

This item shall be ordered at Department option. It will potentially be used to replace faulty or damaged lock assemblies in existing Cabinet Assemblies in the field as well as within cabinet Assemblies furnished for this contract.

See Section 1.2.2 "Special Provisions" for additional requirements.

1.2.5 *Cabinet Foundations*

Cabinet foundations will be either supplied by the SCDOT or will need to be built per specifications as directed by the ENGINEER.

1.2.5.1 Concrete

The Concrete provided shall be CLASS 3000, and shall be mixed, poured, and finished in accordance with SC DOT STANDARD SPECIFICATIONS, Section 701, 702, 703, and 704.

Base mounted Cabinets shall be installed on a properly formed foundation, as shown on the Design Details or the Standards.

1.2.5.2 Reinforcing Steel.

Steel reinforcement shall conform to the requirements of DOT STANDARD SPECIFICATIONS, Section 703.01, which is amended to include the following:

“All references to AASHTO M 31 or ASTM A 615 are hereby deleted and replaced by ASTM A 706 with a single minimum yield strength level of 60,000 psi, designated as Grade 60.”

The bars or wire shall be of the size and type shown on the Design Details or in the Standards.

1.2.5.3 Conduit Elbows

See FURNISH AND INSTALL ELECTRICAL CONDUIT.

Conduit Elbows shall be of the size and type shown on the Plans or the Design Details or Standards.

1.2.5.4 Ground Rod

Ground rods shall be 5/8 inch by 8 feet (minimum) Copper-clad. A No. 6 AWG bare, solid or stranded copper wire shall be used in the ground connection. A Base-mounted Cabinet requires a separate ground rod. A Pole-mounted Cabinet may use the ground rod associated with that pole.

1.2.5.5 Miscellaneous

All components or hardware shall be made of non-corrosive material, or be of the same materials as the item being installed.

1.2.6 *Warranty, Quality Control, Testing, Certification*

1.2.6.1 CALTRANS

All items shall meet the electrical, environmental, and testing requirements as specified in CALTRANS Specifications. The Vendor shall supply with each shipment, a full TEST REPORT of the quality control and the final test of each item. The test reports shall indicate the name of the tester, and shall be signed by a responsible manager. This "Certificate Of Compliance" shall be attached to the Packing List.

The equipment to be furnished shall be of current production, and shall be the Manufacturer's standard model. If any of the equipment furnished is no longer available the supplier shall provide a replacement accepted by the Department at no additional cost.

1.2.6.2 WARRANTIES AND SERVICE

1.2.6.2.1 Warranty Period

The Vendor shall fully guarantee all items, equipment and materials provided under this contract. The duration of the warranty or guarantee shall be the standard of the industry, with a minimum period of TWENTY-FOUR (24) MONTHS from the date of shipment to the Department. The Vendor shall mark each item with the date of shipment. The warranty shall cover all Manufacturer's defects, including parts, labor, and shipping costs. Any item found not in accordance with this Specification will be rejected, and returned to Vendor at the Vendor's expense for immediate replacement. A second occurrence of this infraction will be sufficient reason for total rejection of the contract for that item.

1.2.6.2.2 Repair

The vendor shall have an office and/or authorized factory representative within 250 miles of **central South Carolina (assumed Columbia)** and be able to perform on-site warranty repair or replacement, within 2 working days after receiving complaint. The authorized factory representative shall have a permanent office located within the specified range. This office shall have a permanent street address, Air Conditioning and Heat, a permanent indoor restroom, a listed voice number, fax machine and number, and computer/internet access with a valid e-mail address.

1.2.6.2.3 Extension

Following warranty repair or replacement, the warranty period (for that item or module), shall be extended for an additional period of one (1) year.

1.2.6.2.4 Vendor

If the equipment Vendor is other than the Manufacturer, then the Vendor shall be fully responsible for all warranties and requirements of this Specification.

1.2.6.3 REPARABILITY AND SERVICE

1.2.6.3.1 Service

The Vendor/Manufacturer shall provide services adequate for the operation, repair, and replacement for each item. Adequate service will apply to reasonable response provided by technical personnel experienced with each item.

1.2.6.3.2 Repair Parts

The Vendor shall be able to ship to the Department within three (3) working days, any component parts required to maintain this equipment.

1.2.6.3.3 Maintenance and Repair Services

Complete data on maintenance and repair services shall be available, for the convenience of the Department, in the post-warranty period.

This maintenance data shall include location of the service facility, services offered, turn-around time, and estimated repair costs.

Services shall extend to any agency or municipality using equipment purchased under this contract.

1.2.7 Certification**CATALOG CUTS ARE REQUIRED****1.3 Measurement**

Controller and Cabinet furnished will be measured by EACH TYPE Controller and Cabinet (mounting specified) including miscellaneous electronics, load switches, wiring, electrical connection, ground rod, ground wire, and all related hardware.

1.4 Payment

Furnishing Controller and/or Cabinet accepted and measured as above, will be paid for at the contract unit price.

FURNISH 2070L CONTROLLER	EA
FURNISH MODEL 336S CABINET ASSEMBLY	EA
FURNISH MODEL 332A CABINET ASSEMBLY	EA
FURNISH ALUMINUM EXTENDER BASE	EA
FURNISH MODEL 2010 ECL-IP CONFLICT MONITOR	EA
FURNISH MODEL 200 LOAD SWITCH	EA
FURNISH MODEL 204 FLASHER	EA
FURNISH MODEL 206S POWER SUPPLY	EA
FURNISH MODEL 222 LOOP DETECTOR AMPLIFIER	EA
FURNISH LCD ENHANCED/INTELLIGENT LOOP DETECTOR AMPLIFIER	EA
FURNISH MODEL 242 DC ISOLATOR	EA
FURNISH MODEL 252 AC ISOLATOR	EA
FURNISH MODEL 430 FLASH TRANSFER RELAY	EA
FURNISH MODEL 2070-7A ASYNCHRONOUS SERIAL COMMUNICATION MODULE	EA
FURNISH EXTERNAL DIAL-UP MODEM	EA

M688.9 FURNISH SOLAR POWERED FLASHER ASSEMBLY

1.1 Description

This specification describes requirements for furnishing a Solar Powered Flasher Assembly.

1.2 Materials

1.2.1 24/7 Single Solar 24 Hour Flashing Beacon

1.2.1.1 Overview

This specification is for the Single Beacon Solar 24 Hour Flashing Beacon. Each unit shall consist of a solar engine, LED signal module and signal housing, and mounting hardware. The system shall conform to all provisions of the MUTCD, Chapter 4K, and Flashing Beacons.

1.2.1.2 Mechanical Specifications

The solar engine shall be vented to provide cooling of the battery and electronic system. Venting shall be covered by wire mesh to prevent intrusion of insects. The unit shall have the provision to mount a external device for remote activation. System must have capability to power such device.

1.2.1.3 Solar / Battery System

The solar engine shall have a field replaceable sealed lead acid battery or batteries. Solar panel and battery system shall be 12 Volt DC.

The solar panel or panels shall meet the design qualification and type approval of photovoltaic modules in accordance with IEC 61215. This specification includes radiation testing, thermal testing, and mechanical testing for environmental conditions such as UV-exposure, thermal cycling, as well as degradation of maximum power output.

Battery shall be mechanically secured into the housing. System shall have an auxiliary 12 VDC power output to power third party devices such as wireless radios or sensing equipment.

1.2.1.4 Signal Housing

The signal housing shall meet the equipment standard of the Institute of Transportation Engineers (ITE) Vehicle Traffic Control Signal Heads (VTCSH) Chapter 2.

1.2.1.5 LED Signal Module

The LED signal module shall conform to the mandatory specifications of: Light Emitting Diode (LED) Circular Signal Supplement as required by the Manual of Uniform Traffic Control Devices 2003 Edition Revision 1.

1.2.1.6 Operational Specifications

The system shall conform to all standards for flashing beacons as required in the Manual of Uniform Traffic Control Devices 2003 Edition Revision 1 or current version.

- The beacon shall flash at a rate set by MUTCD.
- The beacon shall have a minimum operating autonomy of 30 days.
- The beacon shall automatically reduce light output in case of low battery situations, reducing risk that the beacons will fail entirely under conditions of poor solar insolation.

1.2.1.7 Activation

The beacon shall operate continuously when the battery is connected. The beacon shall have the option to be turned on by a third party switch or third party device with a compatible contact closure output.

1.2.2 **24/7 Single Compact Solar 24 Hour Flashing Beacon**

1.2.2.1 Overview

This specification is for the Single Beacon Compact Solar 24 Hour Flashing Beacon.

Each unit shall consist of a self-contained solar engine, LED signal module and signal housing, and mounting hardware such that the entire assembly mounts to the top of the pole. The solar engine shall contain all electronics, batteries & solar panels. No additional cabinet is required. The system shall conform to all provisions of the MUTCD, Chapter 4K, and Flashing Beacons. See Diagrams 1a and 1b.

Diagram 1a.
Single Beacon
Compact – Pole
Mount
(Square/Round)



Diagram 1b.
Single Beacon
Compact – Top of
Pole Mount
(4 1/2" Round)



1.2.2.2 Mechanical Specifications

The Solar panel shall be mounted to the solar engine. All batteries and electronics shall be mounted in the solar engine, with no external control cabinet or battery cabinet required. The solar engine shall be vented to provide cooling of the battery and electronic system. Venting shall be covered by wire mesh to prevent intrusion of insects.

The solar engine shall have the provision to mount an external device for remote activation. System must have capability to power such device. Solar engine must contain sufficient space to house third party device inside a sealed enclosure located inside the solar engine.

The entire system must be delivered as a complete unit ready to install and requiring no assembly.

1.2.2.3 Solar / Battery System

The solar engine shall include a minimum 10-watt solar panel. The solar engine shall house a field replaceable sealed lead acid battery or batteries. Solar panel and battery system shall be 12 Volt DC.

The solar panel shall meet the design qualification and type approval of photovoltaic modules in accordance with IEC 61215. This specification includes radiation testing, thermal testing, and mechanical testing for environmental conditions such as UV-exposure, thermal cycling, as well as degradation of maximum power output.

The solar panel shall consist of a solar panel or panels, mounted to the solar engine.

Battery or batteries shall be mechanically secured into the housing. Battery bracket shall enclose the battery in a manner to restrict the thermal expansion of the battery.

System shall have an auxiliary 12 VDC power output to power third party devices such as wireless radios or sensing equipment.

1.2.2.4 Signal Housing

The signal housing shall meet the equipment standard of the Institute of Transportation Engineers (ITE) Vehicle Traffic Control Signal Heads (VTCSH) Chapter 2.

The signal head shall be mounted below the solar engine.

1.2.2.5 LED Signal Module

The LED signal module shall conform to the mandatory specifications of: Light Emitting Diode (LED) Circular Signal Supplement as required by the Manual of Uniform Traffic Control Devices 2003 Edition Revision 1.

1.2.2.6 Operational Specifications

The system shall conform to all standards for flashing beacons as required in the Manual of Uniform Traffic Control Devices 2003 Edition Revision 1 or current version.

- The beacon shall be flash at a rate of set by MUTCD.
- The beacon shall have a night dimming feature.
- The beacon shall have a minimum operating autonomy of 30 days.
- The beacon shall automatically reduce light output in case of low battery situations, reducing risk that the beacons will fail entirely under conditions of poor solar insolation.

1.2.2.7 Activation

The beacon shall operate continuously when the battery is connected. The beacon shall have the option to be turned on by a third party switch or third party device with a compatible contact closure output.

1.2.3 *Dual 24 Hour Solar Powered Flashing Beacon*

1.2.3.1 Overview

This specification is for the solar powered 24 hour flashing beacon. Each unit shall consist of a self-contained solar engine, two LED signal modules and signal housings, and mounting hardware to fit the

installation. The solar engine shall connect to two 12" yellow or red LED lens. The solar engine, mounting hardware, and signal heads shall be available in black, yellow, and green. See Diagrams 2.

Diagram 2.
Dual Beacon
Compact – Top of
Pole Mount
(4 1/2" Round)

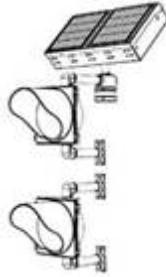

1.2.3.2 Mechanical Specifications

The weight of the solar engine shall not exceed 52 pounds. The solar engine must be able to rotate 360 degrees and tilt for maximum solar energy collection. Batteries shall be field replaceable.

1.2.3.3 Signal Housing

The signal housings shall be constructed of polycarbonate material, and must be adjustable independent from the bracket for lens alignment. The signal housings shall meet the equipment standard of the Institute of Transportation Engineers Vehicle Traffic Control Signal Heads (VTCSH) Chapter 2. The lenses shall be ITE compliant 12" yellow LED lenses.

1.2.3.4 Standards

The system shall conform to all standards for flashing beacons as required in the Manual of Uniform Traffic Control Devices 2003 Edition Revision 1 or current version. These include complying with the VTCSH specifications.

- The flash rate shall be MUTCD compliant.
- The beacons shall have a night dimming feature.
- The beacons shall have a minimum operating autonomy of 30 days
- The beacons shall automatically reduce light output in case of low battery situations, reducing risk that the beacons will fail entirely under conditions of poor solar insolation.

1.2.4 *Dual Solar Powered School Flashing Beacon*

1.2.4.1 Overview

This specification is for the solar powered school flashing beacon. Each unit shall consist of a solar engine, two LED signal modules and signal housings, and mounting hardware with timing device. The system shall conform to all provisions of the MUTCD, Chapter 4K, and Flashing Beacons.

1.2.4.2 Mechanical Specifications

The solar engine shall be vented to provide cooling of the battery and electronic system. Venting shall be covered by wire mesh to prevent intrusion of insects. The solar engine shall have the provision to

mount an external device for remote activation. System must have capability to power such device. Unit must provide a cabinet or contain sufficient space to house third party device inside a sealed enclosure.

1.2.4.3 Solar / Battery System

The solar engine shall have a field replaceable sealed lead acid battery or batteries. Solar panel or panels and battery system shall be 12 Volt DC.

The solar panel or panels shall meet the design qualification and type approval of photovoltaic modules in accordance with IEC 61215. This specification includes radiation testing, thermal testing, and mechanical testing for environmental conditions such as UV-exposure, thermal cycling, as well as degradation of maximum power output.

Battery or Batteries shall be mechanically secured into the housing.

System shall have an auxiliary 12 VDC power output to power third party devices such as wireless radios or sensing equipment.

1.2.4.4 Signal Housing

The signal housings shall meet the equipment standard of the Institute of Transportation Engineers Vehicle Traffic Control Signal Heads (VTCSH) Chapter 2.

1.2.4.5 LED Signal Module

The LED signal module shall conform to the mandatory specifications of: Light Emitting Diode (LED) Circular Signal Supplement as required by the Manual of Uniform Traffic Control Devices 2003 Edition Revision 1.

1.2.4.6 Standards

The system shall conform to all standards for flashing beacons as required in the Manual of Uniform Traffic Control Devices 2003 Edition Revision 1 or current version.

- The flash rate shall be MUTCD compliant.
- The beacons shall have a minimum operating autonomy of 30 days
- The beacons shall automatically reduce light output in case of low battery situations, reducing risk that the beacons will fail entirely under conditions of poor solar insolation.

1.2.4.7 Activation

The beacon shall operate continuously when the battery is connected. The beacon shall have the option to be turned on by a third party switch or third party device with a compatible contact closure output. A timer shall be included in this as an option.

1.2.5 *Dual Compact Solar School Zone Flasher*

1.2.5.1 Overview

This specification is for the Dual Compact Solar School Zone Flasher.

Each unit shall consist of a self-contained solar engine, two LED signal modules and signal housings, and mounting hardware such that the entire assembly with the exception of the bottom LED mounts to the top of the pole. The solar engine shall contain all electronics, batteries & solar panels. No additional cabinet is required. The system shall conform to all provisions of the MUTCD, Chapter 4K, and Flashing Beacons. See Diagram 3.

Diagram 3
Dual Beacon
Compact School
Zone Flasher

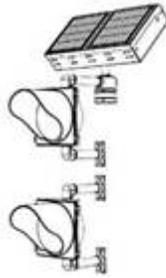

1.2.5.2 Mechanical Specifications

The Solar panel shall be mounted to the solar engine. All batteries and electronics shall be mounted in the solar engine, with no external control cabinet or battery cabinet required. The solar engine shall be vented to provide cooling of the battery or batteries and electronic system. Venting shall be covered by wire mesh to prevent intrusion of insects.

The solar engine shall have the provision to mount an external device for remote activation. System must have capability to power such device. Solar engine must contain sufficient space to house third party device inside a sealed enclosure located inside the solar engine.

The overall weight of the assembly, including mounting hardware, signal housing, LED module, and solar engine shall not exceed 55 lbs.

1.2.5.3 Solar / Battery System

The solar engine shall include a minimum 10-watt solar panel. The solar engine shall house a replaceable sealed lead acid battery or batteries. Solar panel and battery system shall be 12 Volt DC.

The solar panel shall meet the design qualification and type approval of photovoltaic modules in accordance with IEC 61215. This specification includes radiation testing, thermal testing, and mechanical testing for environmental conditions such as UV-exposure, thermal cycling, as well as degradation of maximum power output.

The solar panel shall consist of one single solar panel, mounted to the solar engine.

Battery shall be mechanically secured into the housing. Battery bracket shall enclose the battery in a manner to restrict the thermal expansion of the battery.

System shall have an auxiliary 12 VDC power output to power third party devices such as wireless radios or sensing equipment.

1.2.5.4 Signal Housing

The signal housing shall meet the equipment standard of the Institute of Transportation Engineers (ITE) Vehicle Traffic Control Signal Heads (VTCSH) Chapter 2.

The signal head shall be easily removable from the assembly. The signal housing must be adjustable independent from the bracket for lens alignment.

1.2.5.5 LED Signal Module

The LED signal module shall conform to the mandatory specifications of: Light Emitting Diode (LED) Circular Signal Supplement as required by the Manual of Uniform Traffic Control Devices 2003 Edition Revision 1.

1.2.5.6 Operational Specifications

The system shall conform to all standards for flashing beacons as required in the Manual of Uniform Traffic Control Devices 2003 Edition Revision 1 or current version.

The beacon shall be flash at a rate set by MUTCD. The illuminated period of each flash shall not be less than one-half and not more than two-thirds of the total cycle.

- The beacon shall have a night dimming feature.
- The beacon shall have a minimum operating autonomy of 30 days.
- The beacon shall automatically reduce light output in case of low battery situations, reducing risk that the beacons will fail entirely under conditions of poor solar insolation.

1.2.6 Warranty

The Vendor shall furnish SCDOT with any warranties on equipment and materials that are provided by the Manufacturer or Vendor as normal trade practice.

1.3 Measurement

Furnishing a Solar Powered Flasher Assembly shall be measured by EACH and shall include all electrical connections and all required mounting and incidental hardware.

1.4 Payment

Furnishing a Solar Powered Flasher Assembly, accepted and measured as provided above, will be paid at the contract unit price bid for:

FURNISH SINGLE BEACON/COMPACT/MODEL R247C (INCLUDES ALL ASSOCIATED HARWARE FOR A COMPLETE AND OPERATIONAL ASSEMBLY)	EA
FURNISH SINGLE BEACON/STANDARD/MODEL R247 (INCLUDES ALL ASSOCIATED HARWARE FOR A COMPLETE AND OPERATIONAL ASSEMBLY)	EA
FURNISH DUAL BEACON COMPACT/MODEL R247 DUAL (INCLUDES ALL ASSOCIATED HARWARE FOR A COMPLETE AND OPERATIONAL ASSEMBLY)	EA
FURNISH DUAL BEACON STANDARD/MODEL R829 (INCLUDES ALL ASSOCIATED HARWARE FOR A COMPLETE AND OPERATIONAL ASSEMBLY)	EA
FURNISH DUAL BEACON COMPACT/MODEL R829C (INCLUDES ALL ASSOCIATED HARWARE FOR A COMPLETE AND OPERATIONAL ASSEMBLY)	EA
FURNISH DUAL BEACON COMPACT/MODEL R829C-D4 (INCLUDES ALL ASSOCIATED HARWARE FOR A COMPLETE AND OPERATIONAL ASSEMBLY)	EA

FURNISH DUAL BEACON COMPACT/MODEL R820C (INCLUDES ALL ASSOCIATED HARWARE FOR A COMPLETE AND OPERATIONAL ASSEMBLY)	EA
FURNISH DUAL BEACON STANDARD/MODEL R820 (INCLUDES ALL ASSOCIATED HARWARE FOR A COMPLETE AND OPERATIONAL ASSEMBLY)	EA
FURNISH TIME CLOCK/CONNECTOR/MODELAP22-503544	EA
FURNISH TIME CLOCK SO'WARE KIT/MODELAP22-KIT	EA
FURNISH 12" YELLOW LED/MODEL 47553	EA
FURNISH 12" RED LED/MODEL 48820	EA
FURNISH 1 SECTION SIGNAL HEAD/MODEL CAMSIG	EA
FURNISH SOLAR FLASHER SCHOOL ZONE SOFTWARE/CPK	EA
FURNISH EMERGENCY MANAGEMENT SYSTEM/MODEL 46319	EA
FURNISH 12V DC SEALED BATTERY/MODEL 37912	EA
FURNISH LED HARNESS 15'/MODEL 48901	EA
FURNISH LED HARNESS 36 ' ./MODEL 48902	EA
FURNISH LED HARNESS 75 ' ./MODEL 56928	EA
FURNISH FIXED WEDGE TOP PLATE/BASE ASSEMBLY/WEDGE	EA
FURNISH COMMUNICATION CABLE/SZ FLASHER/MODEL COMSCH	EA
FURNISH UPLOAD HOUSING KIT/MODEL 48941	EA
FURNISH HOUSING BOX FOR TIME SWITCH/MODEL 47256	EA
FURNISH MANUAL ON/OFF SWITCH HARNESS/MODEL47223	EA
FURNISH TOP PLATE WEDGE/MODEL 50571	EA
FURNISH 2" SQUARE POLE MOUNT(C BRACKET)/MODEL47362	EA
FURNISH SLIP FILLER, 1&2 WAY/MODEL SE-3302-P29	EA
FURNISH SIDE-OF-POLE ASSEMBLY/MODEL SP-5641-P29	EA
FURNISH SIDE POLE W/HUB PLATE/MODEL SP-5641-P29	EA
FURNISH 1-WAY TRI-STUD MOUNTING/MODEL SE-0567-P29	EA
FURNISH UPPER/LOWER ARM ASSEMBLY/MODEL SE-3148-P29	EA
FURNISH 1 WAY ASTRO-BRAC ASSEMBLY/MODEL AB-0125-96	EA
FURNISH SPAN WIRE HANGAR/MODEL SP-1004SC-P29	EA
FURNISH HORIZONTAL MOUNT SOLAR ENGINE SUPPORT ARM/MODEL 46560	EA
FURNISH PIPE ADAPTOR FOR WEDGE/MODEL 47504	EA
FURNISH 8' 4 1/2" ALUMINUM PED POLE/MODEL PB-5100-8	EA
FURNISH 10' 4 1/2" PED POLE/MODEL PB-5100-10	EA
FURNISH 12' 4 1/2" PED POLE/MODEL PB-5100-12	EA
FURNISH 15' 4 1/2" PED POLE/MODEL PB-5100-15	EA
FURNISH DOUBLE PUSH BUTTON STATION/MODEL SE-6042	EA
FURNISH ALUMINUM SQUARE PED BASE /MODEL PB-5335-1S	EA
FURNISH PED BASE COLLAR/MODEL PB-5325	EA
FURNISH 2" SQUARE POST MOUNT SINGLE W/SIGNAL/LED/2SQ	EA
FURNISH SOLAR ENG 10W/MODEL R247ENGINE ONLY 10	EA
FURNISH SOLAR ENG 20W/MODEL R247ENGINE ONLY 20	EA
FURNISH SOLAR ENG 10W/SCHOOL/R829ENGINE ONLY10	EA

FURNISH SQUARE WOOD POST MOUNT W/WEDGE/MODEL SWP	EA
FURNISH TOP POLE MOUNT W/WEDGE/MODEL 45RS	EA
FURNISH TOP POLE MOUNT W/WEDGE/MODEL 45RDV	EA
FURNISH TOP POLE MOUNT W/WEDGE DUAL HORIZONTAL/45RDH	EA
FURNISH SIDE POLE MOUNT W/WEDGE/MODELSPS	EA
FURNISH SIDE POLE MOUNT W/WEDGE/DUAL/MODEL SPD	EA
FURNISH MAST ARM MOUNT W/WEDGE/SINGLE/MODEL MAMS	EA
FURNISH MAST ARM MOUNT W/WEDGE/DUAL/MODEL MAMD	EA
FURNISH CPR/AP22 COMMUNICATION CENTRAL/MODEL 501638R	EA
FURNISH CPR2102 UPDATE/MODEL 500900	EA
FURNISH CPR2102 TIME CLOCK/MODEL 503602-D	EA
FURNISH CPR2102 VERIFY UNIT/MODEL 503600-D	EA
FURNISH MASTER RADIO UNIT/POWER SUPPLY/MODEL 503646	EA
FURNISH CPR INTERNAL RADIO/MODEL 503645	EA
FURNISH CPR EXTERNAL RADIO/MODEL 503645E	EA
FURNISH CPR SOLAR REPEATER STATION/MODEL 503649F	EA
FURNISH CPR AC REPEATER STATION/MODEL 503649FAC	EA
FURNISH CPR RADIO REPEATER W/PS/MODEL 503647	EA
FURNISH CPR PROGRAMMING KIT/MODEL 501662NB	EA
FURNISH 10db YAGI ANTENNA/MODEL 503525Y	EA
FURNISH 6db OMNI ANTENNA/MODEL 503525OMNI	EA
FURNISH 11db OMNI ANTENNA/MODEL 505472-11db	EA
FURNISH DISC ANTENNA/MODEL 503544	EA
FURNISH TABLE TOP ANTENNA/MODEL 503501M	EA
FURNISH 25 ' ANTENNA LEAD/CPR RADIO/505472L-25	EA
FURNISH 50 ' ANTENNA LEAD/CPR RADIO/505472L-50	EA
FURNISH 100' ANTENNA LEAD/CPR RADIO/505472L-100	EA
FURNISH 150' ANTENNA LEAD/CPR RADIO/505472L-150	EA
FURNISH CPR RADIO/TIME SWITCH CONVERTER/503648C	EA
FURNISH CPR 2101 TIME SWITCH/503645W	EA
FURNISH 3db WI-FI ANTENNA W/3' LEAD/504413WF	EA
FURNISH WI-FI to TIME SWITCH CONVERTER/503485	EA
FURNISH WI-FI TRANSCEIVER/MODEL 501680	EA
FURNISH ANTENNA BRACKET/MODEL 502356	EA
FURNISH CPR DISPLAY TERMINAL/MODEL 502620	EA
FURNISH CPR AUDIO VISUAL ALARM/MODEL 503626	EA

EXHIBIT 7

FEDERAL-AID PROJECT SUPPLEMENTAL SPECIFICATIONS

EXHIBIT 7

FEDERAL-AID SPECIFICATIONS AND FORMS

FOR

**Replacement of SC 41 Bridge over the Wando River
Charleston / Berkeley Counties**

TABLE OF CONTENTS

SUPPLEMENTAL SPECIFICATIONS.....2

 APPLICATION OF DAVIS-BACON AND RELATED ACTS TO INDEPENDENT TRUCK DRIVERS AND
 MISCELLANEOUS CONSTRUCTION ACTIVITIES2

 REQUIREMENTS FOR FEDERAL AID CONTRACTS WHICH AFFECT SUBCONTRACTORS, DBE
 HAULERS, MATERIAL SUPPLIERS AND VENDORS3

 DISADVANTAGED BUSINESS ENTERPRISES (DBE) -- FEDERAL PROJECTS4

 LATE DISCOVERY OF ARCHAEOLOGICAL/HISTORICAL REMAINS ON FEDERAL AID PROJECTS
 AND APPROVAL OF DESIGNATED BORROW PITS11

 SPECIFIC EQUAL EMPLOYMENT OPPORUNITY RESPONSIBILITIES TRAINING SPECIAL
 PROVISIONS.....12

INSTRUCTIONS TO BIDDERS -- FEDERAL PROJECTS14

REQUIRED CONTRACT PROVISIONS FEDERAL AID CONSTRUCTION CONTRACTS.....19

**STANDARD FEDERAL EQUAL EMPLOYMENT OPPORTUNITY CONSTRUCTION CONTRACT
SPECIFICATIONS30**

GENERAL DECISION NUMBER SC47ERROR! BOOKMARK NOT DEFINED.

DISADVANTAGED BUSINESS ENTERPRISES (DBE) COMMITTAL SHEET37

June 13, 1990

APPLICATION OF DAVIS-BACON AND RELATED ACTS TO INDEPENDENT TRUCK DRIVERS AND MISCELLANEOUS CONSTRUCTION ACTIVITIES

The Davis-Bacon and Related Acts apply when:

- 1) A Contractor or Subcontractor hires a trucking firm or fleet of trucks to haul materials from a plant, pit, or quarry, which has been established specifically to serve (or nearly so) a particular project or projects covered by Davis-Bacon and Related Acts.
- 2) A Contractor or Subcontractor hires a trucking firm or fleet of trucks to haul material from a non-commercial stockpile or non-commercial storage site outside the limits of the project to the project site.
- 3) A Contractor or Subcontractor hires a trucking firm or fleet of trucks to haul excavated materials away from a Davis-Bacon covered project.
- 4) A contractor or Subcontractor rents or leases equipment with an operator to perform work as called for under a Davis-Bacon construction contract.
- 5) A common carrier is used for the transportation of materials from an exclusive material supply facility to fulfill the specific need of a construction contract.

The fleet owner is not considered a Subcontractor with regard to the 70% subcontracting limitations and would not have to be approved as a Subcontractor. However, payrolls must be submitted by truck fleet owner covering the truck drivers, and all requirements such as predetermined wages, overtime, etc., are applicable. Legitimate owner-operators (truck owner driving his own truck) must appear on the payroll by name and notation "truck Owner Operator" with no hours, etc. shown.

The Davis-Bacon and Related Acts do not apply when:

- 1) A Contractor or Subcontractor hires a trucking firm or fleet of trucks to haul materials from a commercial plant, pit, or quarry which had previously been established for commercial use and regularly sell materials to the general public.
- 2) A Contractor or Subcontractor hires a trucking firm or fleet of trucks to haul materials from an established commercial plant, pit, or quarry to a stockpile outside the limits of the project.
- 3) Bona fide owner-operators of trucks, who are independent contractors, use their own equipment to haul materials to or from or on a Davis-Bacon covered project. (One man-One truck)

The fleet owner is not considered a Subcontractor with regard to the 70% subcontracting limitation and would not have to be approved as a Subcontractor.

EXHIBIT 7 - FEDERAL AID SPECIFICATIONS AND FORMS

March 1, 2010

**REQUIREMENTS FOR FEDERAL AID CONTRACTS WHICH AFFECT SUBCONTRACTORS, DBE
HAULERS, MATERIAL SUPPLIERS AND VENDORS**

- A. The contractor's attention is directed to the requirements of Section I.2 in Form FHWA 1273 that is included in your contract documents as the Supplemental Specification "Required Contract Provisions Federal-Aid Construction Contracts". Section I.2 requires that "the contractor shall insert in each subcontract all of the stipulations contained in the Required Contract Provisions". This requirement also applies to lower tier subcontractors or purchase orders. These provisions must be physically included in your subcontracts. A reference to the applicable specification will not suffice.
- B. The contractor's attention is directed to the requirements of the Supplemental Specification "Standard Federal Equal Employment Opportunity Construction Contract Specifications". Section 2 requires that the provisions of this specification must be physically included in each subcontract with a value of \$10,000 or greater.
- C. The contractor's attention is directed to the requirements of the Equal Employment Opportunity Performance certifications in the Proposal Form Certifications and Signatures section of the contract. Section 1 concerning Equal Employment Opportunity must be physically included in each subcontract.
- D. Prior to the issuance of formal approval, all DBE subcontracts must include a signed copy of the subcontract agreement between the Prime Contractor and the DBE Subcontractor.
- E. Prior to the issuance of formal approval, of any DBE haulers, the contractor must submit a signed copy of the hauling agreement.
- F. The contractor's attention is further directed that sections 1, 2, 3, 8, 9, and 11 of Form FHWA 1273, or Sections 1, 3, 8 and 10 of Form 1316 (for Appalachian contracts only) must be physically included in each purchase agreement with a value of \$10,000 or greater with a vendor or supplier, and in open-end contracts where individual purchases are less than \$10,000 but where the total purchases accumulate to \$100,000 or more per year.

March 3, 2010

DISADVANTAGED BUSINESS ENTERPRISES (DBE) -- FEDERAL PROJECTS

1. POLICY

It is the policy of the South Carolina Department of Transportation (SCDOT) to ensure nondiscrimination in the award and administration of federally assisted contracts and to use Disadvantaged Business Enterprises (DBE's) in all types of contracting and procurement activities according to State and Federal laws. To that end, the SCDOT has established a DBE program in accordance with regulations of the United States Department of Transportation (USDOT) found in 49 CFR Part 26.

2. CONTRACTOR'S OBLIGATIONS

A. No Discrimination. Neither the Contractor nor its subcontractors shall discriminate on the basis of race, color, national origin, or gender in the performance of this contract. The Contractor shall carry out the applicable requirements of 49 CFR Part 26 and these supplemental specifications in the award and administration of this contract. Failure by the contractor to carry out these requirements is a material breach of the contract, and may result in the termination of the contract or such other remedy as SCDOT deems appropriate.

B. Meeting both the Goal and Commitment or Making Good Faith Efforts to Meet the Goal and Commitments. It is the Contractor's responsibility to meet the DBE contract goal and committals stated in the "Instructions to Bidders –Federal Projects – DBE Requirements" (hereinafter referred to as "Instructions to Bidders") or to make good faith efforts to meet the DBE contract goal/commitments. The Instructions to Bidders is incorporated herein by reference and made a part of this contract. Failure to meet the goal or commitments to specific DBEs listed on the committal sheet or to demonstrate good faith efforts to meet the goal or commitments may result in any one or more of the following sanctions:

- (1) Withholding monthly progress payments;
- (2) Declaring the Contractor in default pursuant to Section 108.10 of the Standard Specifications and terminating the contract;
- (3) Assessing sanctions in the amount of the difference in the DBE contract committal and the actual payments made to each certified DBE's;
- (4) Disqualifying the Contractor from bidding pursuant to Regulation 63-306, Volume 25A, of the S. C. Code of Laws; and/or
- (5) Requiring the Contractor to obtain DBE participation on future contracts to the extent the Contractor failed to meet or use good faith efforts to meet the DBE contract goal.

C. Using the DBE's shown on the Committal Sheet to Perform the Work. The Contractor must utilize the specific DBE's listed on the "DBE Committal Sheet" to perform the work and supply the materials for which each is listed unless the Contractor obtains prior written approval from the Director of Construction to perform the work with other forces or obtain the materials from other sources (See Replacement Procedures in Section 3(B)) The Contractor shall not be entitled to any payment for such work or material unless it is performed or supplied by the listed DBE or, with prior written approval of the Director of Construction, by other forces (including those of the Contractor). Failure to meet a commitment to a specific DBE may result in the sanctions listed in section 2B above, unless prior written approval is obtained for replacement of the committed DBE.

D. Incorporating Certain Provisions in Subcontracts. **The Contractor shall provide SCDOT with a copy of all DBE subcontracts.** The Contractor shall ensure that all subcontracts or an agreement with DBE's to supply labor or materials require that the subcontract and all lower tier subcontracts be performed in accordance with these Supplemental Specifications. The contractor is advised to insert the following provision in each subcontract or agreement: "This contract or agreement shall be performed in accordance with the requirements of the SCDOT Supplemental Specification entitled "Disadvantaged Business Enterprises (DBE) – Federal Projects" dated February 2004."

3. REPLACEMENT OF CERTIFIED DBE'S

A. Requirement for Replacement. The following shall apply to replacement of a DBE listed on the "DBE Committal Sheet":

- (1) *When a DBE listed on the DBE committal sheet (hereafter referred to as a "committed DBE") is unable or unwilling to perform the work in accordance with the subcontract, the Contractor shall follow the replacement procedures in Section 3(B). Failure on the part of the Contractor to comply with this requirement shall constitute a breach of contract and may be cause for the imposition of the sanctions set forth in Section 2(B).*
- (2) *When a committed or non-committed DBE is decertified or removed from the SC Unified DBE Directory after execution of a valid subcontract agreement with the Contractor.*
 - a. The Contractor may continue to utilize the decertified DBE on the contract and receive credit toward the DBE contract goal for the DBE's work unless the Contractor is implicated in the DBE decertification. However, the Contractor is encouraged to replace the decertified DBE with a certified DBE where feasible, to assist SCDOT in meeting the overall statewide DBE goal.
 - b. If a *committed or non-committed* DBE is removed from the SC Unified DBE Directory due to graduation from the DBE program, the Contractor may continue to utilize the graduated DBE on the contract and receive credit toward the DBE contract goal for the DBE's work.
- (3) *When a committed DBE is decertified or removed from the SC Unified DBE Directory prior to execution of a valid subcontract agreement with the Contractor, the Contractor shall follow the replacement procedures in Section 3(B). Failure on the part of the Contractor to comply with this requirement shall constitute a breach of the contract and may be cause for the imposition of the sanctions set forth in Section 2(B) above.*

B. Replacement Procedures. In order to replace a *committed* DBE, the Contractor must obtain prior approval from the Director of Construction. To request such approval, the Contractor shall notify the Director of Construction and the DBE, and provide documentation of the need and reasons for replacement. If the DBE consents to the replacement, the Contractor shall also provide the Director of Construction with the DBE's written consent. If the DBE's consent cannot be obtained, the Contractor shall notify the Director of Construction that the DBE's consent could not be obtained. In no case shall the Contractor's ability to negotiate a more advantageous contract with another subcontractor be considered a valid basis for replacement. If the Contractor obtains the Director of Construction's approval for the replacement, the Contractor shall replace the listed DBE with another certified DBE or make good faith efforts to do so as set forth in Section 3(C). Any DBE who is certified at the time of replacement may be used as a replacement. If the Director of Construction does not approve of replacement, the Contractor shall continue to use the *committed* DBE in accordance with the contract. Failure to do so may constitute cause for imposition of any of the sanctions set forth in Section 2(B).

C. Good Faith Efforts. After approval for replacement is obtained, if the Contractor is not able to find a replacement DBE, the Contractor shall provide the Director of Construction with documentation of its good faith efforts to find a replacement. This documentation shall include, but is not limited to, the following:

- (1) Copies of written notification to certified DBE's that their interest is solicited in subcontracting the work defaulted by the previous certified DBE or in subcontracting other items of work in the contract.
- (2) Statement of efforts to negotiate with certified DBE's for specific subbids including at a minimum:
 - a. Names, addresses and telephone numbers of certified DBE's who were contacted;

EXHIBIT 7 - FEDERAL AID SPECIFICATIONS AND FORMS

- b. Description of the information provided to certified DBE's regarding the plans and specifications for portions of the work to be performed;
 - c. Statement of why additional agreements with certified DBE's were not reached.
- (3) For each certified DBE contacted but rejected, the reasons for the Contractor's rejection. Failure to find a replacement DBE at the original price is not in itself evidence of good faith.
- (4) Documentation demonstrating that the Contractor contacted SCDOT's DBE Supportive Service contractor for assistance in locating certified DBE's willing to take over that portion of work or do other work on the contract.

If SCDOT determines that the Contractor has made good faith efforts to replace the listed DBE with another certified DBE, then the remaining portion of the DBE's work shown on the "DBE Committal Sheet" can be completed by the Contractor's own forces or by a non-DBE subcontractor approved by the SCDOT. The Contractor will not be required to make up that part of the DBE goal attributable to the portion of work not completed by the listed DBE, and this shortfall in meeting the DBE goal will be waived by the SCDOT.

If SCDOT determines that the Contractor has not made good faith efforts to replace the listed DBE with another certified DBE, such failure may constitute cause for imposition of any of the sanctions set forth in Section 2(B).

D. Payment from SCDOT. The Contractor shall not be entitled to payment for work or material committed to a listed DBE unless:

- (1) The work is performed by the *committed* DBE; or
- (2) The work is performed by another certified DBE after the Director of Construction has given approval to replace the listed DBE as provided above; or
- (3) The work is performed by a non-DBE after SCDOT determines that the Contractor has demonstrated good faith efforts to replace the listed DBE as provided above.

4. COUNTING CERTIFIED DBE PARTICIPATION TOWARD MEETING THE DBE GOAL

DBE participation shall be measured by the actual, verified payments made to DBE's subject to the following rules (all references to "DBE" herein shall mean "certified DBE"). The Contractor is bound by these rules in regard to receiving and reporting credit toward the DBE contract goal. The Contractor shall report on DBE Quarterly Reports only the amounts properly attributable toward the goal under these rules.

A. General Counting Rules.

- (1) The entire amount of that portion of a construction contract (or other contract not covered by paragraph A(2) of this section) that is performed by the DBE's own forces may be counted toward the goal. The cost of supplies and materials obtained by the DBE for the work of the contract, including supplies purchased or equipment leased by the DBE (except supplies and equipment the DBE subcontractor purchases or leases from the prime contractor or its affiliate) can be counted toward the goal.
- (2) When a DBE subcontracts part of the work of its contract to another firm, the value of the subcontracted work may be counted toward DBE goals only if the subcontractor is also a DBE. Work that a DBE subcontracts to a non-DBE firm does not count toward the DBE goals.
- (3) The Contractor can count expenditures to a DBE only if the DBE is certified by SCDOT, except as provided in section 3A(2) of these supplemental specifications, in the event a DBE loses eligibility status after a subcontract is signed.
- (4) The Contractor can count expenditures to a DBE only after the DBE has actually been paid.

EXHIBIT 7 - FEDERAL AID SPECIFICATIONS AND FORMS

B. Joint Ventures. When a DBE performs as a participant in a joint venture, the portion of the total dollar value of the contract equal to the distinct, clearly defined portion of the work of the contract that the DBE performs with its own forces can be counted toward DBE goals. A joint venture must be approved by the Director of Construction prior to start of the contract.

C. Commercially Useful Function. Expenditures to a DBE contractor can be counted toward DBE goals only if the DBE is performing a commercially useful function on that contract:

- (1) A DBE performs a commercially useful function when it is responsible for execution of the work of the contract and is carrying out its responsibilities by actually performing, managing, and supervising the work involved. To perform a commercially useful function, the DBE must also be responsible, with respect to materials and supplies used on the contract, for negotiating price, determining quality and quantity, ordering the material, and installing (where applicable) and paying for the material itself. To determine whether a DBE is performing a commercially useful function, SCDOT will evaluate the amount of work subcontracted, industry practices, whether the amount the firm is to be paid under the contract is commensurate with the work it is actually performing and the DBE credit claimed for its performance of the work, and other relevant factors.
- (2) A DBE does not perform a commercially useful function if its role is limited to that of an extra participant in a transaction, contract, or project through which funds are passed in order to obtain the appearance of DBE participation. In determining whether a DBE is such an extra participant, SCDOT will examine similar transactions, particularly those in which DBE's do not participate.
- (3) If a DBE does not perform or exercise responsibility for at least 30 percent of the total cost of its contract with its own work force, or the DBE subcontracts a greater portion of the work of a contract than would be expected on the basis of normal industry practice for the type of work involved, SCDOT will presume that it is not performing a commercially useful function.
- (4) When a DBE is presumed not to be performing a commercially useful function as provided in paragraph (3) of this section, the DBE may present evidence to rebut this presumption. SCDOT may determine that the firm is performing a commercially useful function given the type of work involved and normal industry practices.
- (5) SCDOT's decisions on commercially useful function matters are subject to review by the concerned operating administration, but are not administratively appealable to the USDOT.

D. Special Rules for Trucking Companies. SCDOT will use the following rules to determine whether a DBE trucking company is performing a commercially useful function and what portion of the DBE work can be counted toward DBE goals:

- (1) ***DBE must control all work.*** To be considered as performing a commercially useful function, the DBE must be responsible for the management and supervision of the entire trucking operation for which it is responsible on a particular contract, and there cannot be a contrived arrangement for the purpose of meeting DBE goals.
- (2) ***DBE must "own" at least one truck.*** The DBE must itself own and operate at least one fully licensed, insured, and operational truck used on the project. For purposes of this section, a DBE will be considered to "own" a truck if:
 - a) the truck is titled in the DBE's name; or,
 - b) the DBE leases the truck under a valid lease-to-own agreement and the driver of the truck is an employee of the DBE.The DBE must submit documentation to SCDOT to establish the number of trucks the DBE owns, operates and insures. The DBE must submit the documentation to SCDOT's Office of Business Development and Special Programs at the time of certification, annual reporting on certification requirements, or at any time during the year that the DBE obtains additional trucks.

EXHIBIT 7 - FEDERAL AID SPECIFICATIONS AND FORMS

- (3) **Counting DBE trucking toward DBE goal.** The Contractor can count toward DBE goals the total value of the transportation services the DBE provides using trucks the DBE owns, insures, and operates using drivers the DBE employs.
- (4) **Counting subcontracted DBE trucking toward DBE goal.** The DBE may subcontract with another DBE firm, including an owner-operator who is certified as a DBE, to provide trucks on a project. In this case, the Contractor may count toward the DBE goal the total value of the transportation services provided by the DBE subcontractor.
- (5) **Counting subcontracted non-DBE trucking toward the goal.** The DBE may subcontract with a non-DBE firm, including an owner-operator, to provide trucks on a project. Prior to beginning work, the DBE must provide SCDOT's Resident Construction Engineer with a list identifying all DBE and non-DBE trucks and truck numbers that will be used on the project. In this case, the Contractor may count toward the DBE goal the total value of the transportation services provided in each quarter by the non-DBE trucks, not to exceed the value of the transportation services provided by DBE-owned trucks in that quarter. For example, in a given quarter, if DBE-owned trucks provide transportation services of \$50,000, while non-DBE trucks provide transportation services of \$75,000, a maximum of \$100,000 can be counted toward the DBE goal in that quarter.

NOTE: DBE firms may not receive credit for DBE participation when leasing non-DBE owned trucks from the Prime contractor the DBE firm is subcontracted with as 49 CFR 26.55(a)(1) applies.

E. DBE Manufacturers and Dealers. The Contractor can count expenditures with DBEs for materials or supplies toward DBE goals in accordance with the following rules:

- (1) *DBE Manufacturers.* If the materials or supplies are obtained from a DBE manufacturer, the Contractor can count 100 percent of the cost of the materials or supplies toward DBE goals. For purposes of this paragraph, a manufacturer is a firm that operates or maintains a factory or establishment that produces, on the premises, the materials, supplies, articles, or equipment required under the contract and of the general character described by the specifications. The DBE must be listed as a "manufacturer" in the SCDOT's DBE directory to be considered a manufacturer for purposes of these counting rules.
- (2) *DBE Dealers.* If the materials or supplies are purchased from a DBE regular dealer, the Contractor can count 60 percent of the cost of the materials or supplies toward DBE goals. For purposes of this section, a regular dealer is a firm that owns, operates, or maintains a store, warehouse, or other establishment in which the materials, supplies, articles or equipment of the general character described by the specifications and required under the contract are bought, kept in stock, and regularly sold or leased to the public in the usual course of business. The DBE must be listed as a "dealer" in the SCDOT's DBE directory to be considered a dealer for purposes of these counting rules.
- (3) *DBE Brokers.* The Contractor cannot count toward the DBE goal fees charged by a DBE who is neither a manufacturer nor a dealer. In this case the DBE is merely a broker of the supplies or materials.

5. JOINT CHECKS

The Director of Construction must approve all requests for a Contractor to issue and use joint checks with a DBE. The following conditions apply:

- a) The DBE must submit a request to the Director of Construction which includes a formalized agreement between all parties that specify the conditions under which the arrangement will be permitted;

EXHIBIT 7 - FEDERAL AID SPECIFICATIONS AND FORMS

- b) The DBE remains responsible for all other elements of 26.55(c)(1). SCDOT must clearly determine that independence is not threatened because the DBE retains final decision making responsibility;
- c) There can be no requirement by the prime contractor that a DBE use a specific supplier nor the prime contractors negotiated unit price.

6. REPORTS

The Contractor shall furnish to the SCDOT the following reports and information. THIS REQUIREMENT APPLIES REGARDLESS OF WHETHER THERE IS A CONTRACT GOAL ASSIGNED TO THE CONTRACT.

A. DBE Quarterly Reports. The Contractor shall provide to the SCDOT DBE Quarterly Reports showing the dollar amount of payments to each certified DBE. The Contractor and each DBE that received payment must sign the report. The Contractor's and DBE's signature on the Quarterly Report shall constitute certification that the DBE has performed the work and that the Contractor is entitled to credit toward the DBE goal for the amount shown in accordance with the counting rules set forth in Section 4. The report shall include the amount paid each DBE for the quarter and the total amount paid to each DBE on the contract. The report must include DBE subcontractors, hauling firms, and suppliers. The report shall be submitted in duplicate to the Resident Construction Engineer by the 15th of the month after each calendar quarter (January, April, July, and October 15). Failure to submit the quarterly report may result in the withholding of monthly progress and/or final payment. The Quarterly Report must be submitted for each quarter even if no payments have been made to a DBE in that quarter. When no payments have been made to a DBE in a quarter, DBE's are not required to sign the report.

B. Trucker's Reports. All DBE haulers must complete and submit a DBE Trucker's Report along with the DBE quarterly report when the DBE leases trucks from another firm. The DBE hauler must list all trucks leased, payments made to the lessee during the quarter, and identify whether leased truck is owned by a certified DBE or non-DBE. DBE Haulers must also submit one copy of each lease agreement to the RCE prior to the start of work for each truck leased. A lease must indicate that the DBE has exclusive use of and control over the truck. This does not preclude the leased truck from working for others during the term of the lease with the consent of the DBE, so long as the lease gives the DBE absolute priority for use of the leased truck. Leased trucks must display the name and identification number of the DBE.

C. Other Documents. Upon request of SCDOT, the Contractor and all subcontractors shall furnish documents, including subcontracts, necessary to verify the amount and costs of the materials or services provided by certified DBE suppliers or subcontractors. The Contractor shall keep the documents that verify this information for at least three years from the date of final settlement of the contract. Failure to provide these documents upon request may result in the withholding of monthly progress and/or final payment or disqualifying the Contractor from bidding pursuant to Regulation 63-306, Volume 25A of the S.C. Code of Laws.

7. CONTRACT COMPLETION – DETERMINATION OF WHETHER CONTRACTOR HAS MET THE GOAL OR MADE GOOD FAITH EFFORTS

a. Review by SCDOT. After receipt of the final DBE Quarterly Reports, the SCDOT will review the necessary contract documentation to determine whether the Contractor has met the DBE commitments and contract goal.

b. Notification of Failure to Meet Goal. If the documentation indicates that the Contractor has not met the DBE commitments and contract goal, the Director of Construction will notify the Contractor and request documentation of the Contractor's good faith efforts to meet the goal.

c. Determination of Good Faith Efforts. The Contractor shall submit documentation demonstrating good faith efforts to meet the contract commitments and goal to the Director of Construction within 30 days of the date of the "Notification of Failure to Meet Goal." The Director of

EXHIBIT 7 - FEDERAL AID SPECIFICATIONS AND FORMS

Construction will provide the Contractor with written notice of SCDOT's determination whether good faith efforts have been demonstrated.

d. Request for Reconsideration. If the Contractor disagrees with SCDOT's determination, the Contractor may request a reconsideration by filing a written request with the Director of Construction within ten (10) days after receipt of the determination. The Contractor shall submit any additional documentation that it wishes to be considered in support of its position. If the Contractor fails to request a reconsideration within ten (10) days, the determination shall be final. If the Contractor requests reconsideration, the State Highway Engineer shall appoint an official who did not take part in the original determination (hereinafter referred to as the "Reconsideration Official"). The Reconsideration Official will contact the Contractor and schedule a meeting with the Contractor. The meeting will be held at the SCDOT Headquarters Building in Columbia. At the meeting, the Contractor will have an opportunity to present oral and written evidence to demonstrate that good faith efforts were made to meet the DBE commitments and contract goal. The Reconsideration Official may also consider evidence presented by SCDOT at the same meeting. After the meeting, the Reconsideration Official will issue a written report and recommendation to the State Highway Engineer. The State Highway Engineer shall make the final decision on the issue. The Director of Construction will notify the Contractor of the final decision in writing.

August 7, 1991

LATE DISCOVERY OF ARCHAEOLOGICAL/HISTORICAL REMAINS ON FEDERAL AID PROJECTS AND APPROVAL OF DESIGNATED BORROW PITS

A. Late Discovery of Archaeological/Historical Remains on Federal Aid Projects.

1. Responsibilities:

The Contractor and subcontractors must notify their workers to watch for the presence of any prehistoric or historic remains, including but not limited to arrowheads, pottery, ceramics, flakes, bones, graves, gravestones, or brick concentrations. If any such cultural remains are encountered, the Resident Construction Engineer shall be immediately notified and all work in the vicinity of the discovered materials or site shall cease until the Department's Staff Archaeologist or the State Highway Engineer directs otherwise.

2. Applicability:

This provision covers all areas of ground disturbance resulting from this federal - aid contract, including but not limited to road construction, Department designated borrow pits, Contractor furnished borrow pits, and/or staging areas.

3. Cost Reimbursement and Time Delays:

Any extra work required by A(1) above within the project right of way or on Department designated borrow pits (see below) will be paid for in accordance with Subsection 104.05 of the Standard Specifications. Extra contract time may be provided under Subsection 108.06 of the Standard Specifications for archaeological work within the project right of way or on designated borrow pits.

NOTE: On Contractor furnished borrow pits the contractor is not entitled to any additional time or money for delay on impact resulting from A(1) above or for extra work required by A(1) above. Therefore, contractors may wish to retain professional archaeological services to better ensure that borrow pit areas are cleared of archaeological/historical remains prior to use on Federal aid projects.

B. Approval of Designated Borrow Pits on Federal Aid Projects (Plant Sites which qualify as commercial are not included).

In instances where the Department specifically designates the location of borrow pits on project plans or in contract specifications for use on a Federal aid project, an archaeological survey will be performed by Department archaeologists prior to award of contract.

This provision also applies to designated disposal sites, staging areas, haul roads, and job site field offices.

EXHIBIT 7 - FEDERAL AID SPECIFICATIONS AND FORMS

August 20, 1975
Revised April 1, 2004

SPECIFIC EQUAL EMPLOYMENT OPPORTUNITY RESPONSIBILITIES
TRAINING SPECIAL PROVISIONS

This Training Special Provision supersedes Subparagraph 7b of the Special Provision entitled "Specific Equal Employment Opportunity Responsibilities", (Attachment 1), and is in implementation of 23 U.S.C. 140(a).

As part of the contractor's equal employment opportunity affirmative action program, training shall be provided as follows:

The contractor shall provide on-the-job training aimed at developing full journeymen in the type of trade or job classification involved.

THE NUMBER OF TRAINEES TO BE TRAINED UNDER THE SPECIAL PROVISION WILL BE.

Road – 4 (at 520 hours each).
Bridge – 2 (at 1040 hours each).

In the event that a Contractor subcontracts a portion of the contract work, he shall determine how many, if any, of the trainees are to be trained by the subcontractor, provided however, that the Contractor shall retain the primary responsibility for meeting the training requirements imposed by this Special Provision. The Contractor shall also insure that this training Special Provision is made applicable to such subcontract. Where feasible, 25 percent of apprentices or trainees in each occupation shall be in their first year of apprenticeship or training.

The number of trainees shall be distributed among the work classifications on the basis of the Contractor's needs and the availability of journeymen in the various classifications within a reasonable area of recruitment. Prior to commencing construction, the Contractor shall submit to the State Highway Agency for approval the number of trainees to be trained in each selected classification and training program to be used. Furthermore, the Contractor shall specify the starting time for training in each of the classifications. The Contractor will be credited for each trainee employed by him on the contract work who is currently enrolled or becomes enrolled in an approved program.

Training and upgrading of minorities and women toward journeyman status is a primary objective of this Training Special Provision. Accordingly, the Contractor shall make every effort to enroll minority trainees and women (e.g., by conducting systematic and direct recruitment through public and private sources likely to yield minority and women (trainees)) to the extent that such persons are available within a reasonable area of recruitment. The contractor will be responsible for demonstrating the steps that he has taken in pursuance thereof, prior to a determination as to whether the Contractor is in compliance with this Training Special Provision. This training commitment is not intended, and shall not be used, to discriminate against any applicant for training, whether a member of a minority group or not.

No employee shall be employed as a trainee in any classification in which he has successfully completed a training course leading to journeyman status or in which he has been employed as a journeyman. The Contractor should satisfy this requirement by including appropriate questions in the employee application or by other suitable means. Regardless of the method used the Contractor's records should document the findings in each case.

The minimum length and type of training for each classification will be as established in the training program selected by the Contractor and approved by the State Highway Agency and the Federal Highway Administration. The State Highway Agency and the Federal Highway Administration shall approve a program if it is reasonably calculated to meet the equal employment opportunity obligations of the Contractor and to qualify the average trainee for journeyman status in the classification concerned by the end of the training period. Furthermore, apprenticeship programs registered with the U.S. Department of Labor, Bureau of Apprenticeship and Training, or with a State apprenticeship agency recognized by the Bureau and training programs approved but not necessarily sponsored by the U.S. Department of Labor, Manpower Administration, Bureau of Apprenticeship and Training shall also be considered acceptable provided it is being administered in a manner consistent with the equal employment obligations of Federal Aid highway construction contracts. Approval or acceptance of a training program shall be obtained from the State prior to commencing work on the classification covered by the program. It is the intention of these provisions that training is to be provided in the

EXHIBIT 7 - FEDERAL AID SPECIFICATIONS AND FORMS

construction crafts rather than clerk-typists or secretarial-type positions. Training is permissible in lower level management positions such as office engineers, estimators, timekeepers, etc., where the training is oriented toward construction applications. Training in the laborer classification may be permitted provided that significant and meaningful training is provided and approved by the division office. Some off-site training is permissible as long as the training is an integral part of an approved training program and does not comprise a significant part of the overall training.

Except as otherwise noted below, the cost for the training will be included in the contract price. There will be no reimbursement given by SCDOT for the hours of training that are provided on this project. However, a "Statement of Completed Training" will be required at the end of the project. The fact that the cost of the training must be included in the contract does not prohibit the contractor from receiving training program funds from other sources, if he so desires. Training hours may be counted if training is done off-site where the contractor does one or more of the following and the trainees are concurrently employed on a Federal Aid project: contributes to the cost of the training, provides the instruction to the trainee, or pays the trainee's wages during the off-site training period.

The training requirement will not be considered completed by the Contractor if either the failure to provide the required training, or the failure to hire the trainee as a journeyman, is caused by the Contractor and evidences a lack of good faith on the part of the Contractor in meeting the requirements of this Training Special Provision. It is normally expected that a trainee will begin his training on the project as soon as feasible after start of work the skill involved and remain on the project as long as training opportunities exist in his work classification or until he has completed his training program. It is not required that all trainees be on board for the entire length of the contract. A Contractor will have fulfilled his responsibilities under this Training Special Provision if he has provided acceptable training to the number of trainees specified. The number trained shall be determined on the basis of the total number enrolled on the contract for a significant period.

Trainees will be paid at least 60 percent of the appropriate minimum journeyman's rate specified in the contract for the first half of the training period, 75 percent for the third quarter of the training period, and 90 percent for the last quarter of the training period, unless apprentices or trainees in an approved existing program are enrolled as trainees on this project. In that case, the appropriate rates approved by the Departments of Labor or Transportation in connection with the existing program shall apply to all trainees being trained for the same classification who are covered by this Training Special Provision.

The Contractor shall furnish the trainee a copy of the program he will follow in providing the training. The Contractor shall provide each trainee with a certification showing the type and length of training satisfactorily completed.

The Contractor will provide for the maintenance of records and furnish periodic reports documenting his performance under this Training Special Provision, as required under the SCDOT approved training program.

Meeting the On-the-job Training Requirements or Making Good Faith Efforts to Meet the On-the-job Training Requirements. It is the Contractor's responsibility to meet the On-the-job Training Requirements stated in this section. Failure to meet the requirement or demonstrate good faith efforts, as determined by SCDOT, to meet the requirement may result in any one or more of the following sanctions:

- (1) Withholding monthly progress payments;
- (2) Declaring the Contractor in default pursuant to Section 108.10 of the Standard Specifications and terminating the contract;
- (3) Disqualifying the Contractor from bidding pursuant to Regulation 63-306, Volume 25A, of the S. C. Code of Laws; and/or
- (4) Requiring the Contractor to obtain On-the-job Training participation on future contracts to the extent the Contractor failed to meet or use good faith efforts to meet the On-the-job training contract requirement.

April 2, 2011

INSTRUCTIONS TO BIDDERS -- FEDERAL PROJECTS
DBE REQUIREMENTS

This project is partially funded with federal-aid highway funds, and is subject to the requirements for participation of Disadvantaged Business Enterprises (DBEs) set forth in 49 CFR Part 26. Therefore, there may be a goal set for participation of DBEs in this contract. If there is a DBE contract goal, it will be shown in Section 1 below. If there is a DBE contract goal, the Contractor is subject to the requirements set forth in the Supplemental Specifications in this contract entitled "Disadvantaged Business Enterprises (DBE) -- Federal Projects (hereinafter referred to as the "DBE Supplemental Specifications"). The Contractor must report DBE participation to the South Carolina Department of Transportation (SCDOT) quarterly by filing a Quarterly Report form (see Section 5 of the DBE Supplemental Specifications.)

Regardless of whether a contract goal is specified in Section 1, the Contractor shall not discriminate on the basis of race, color, national origin, or gender in the performance of this contract.

1. DBE CONTRACT GOAL

The Department's overall DBE program goal is 11%, and the Contractor is encouraged to use all available and reasonable means to assist the SCDOT in meeting this goal. The goal for DBE participation for this contract is shown below as the percentage of the total contract amount bid by the Contractor.

Disadvantaged Business Enterprises Contract Goal **7.5 %**

The Contractor shall exercise all necessary and reasonable steps to ensure that DBEs perform services or provide materials on this contract in an amount that meets or exceeds the DBE contract goal. Submitting the electronic bid proposal shall constitute an agreement by the bidder that it will meet or exceed the DBE contract goal or make good faith efforts to meet the goal. Failure to meet the contract goal or make good faith efforts to meet the contract goal may result in the sanctions listed in Section 2 of the DBE Supplemental Specifications.

2. DBE COMMITMENT

Each bidder shall enter all the information regarding how it intends to meet the DBE goal in the electronic bid folder entitled "DBE List". The listing of DBEs shall constitute a commitment by the bidder to utilize the listed DBEs, subject to the replacement provisions in Section 3 of the DBE Supplemental Specifications. Failure to utilize the listed DBE subcontractor(s) may result in the sanctions listed in Section 2 of the DBE Supplemental Specifications.

In meeting the DBE contract goal, the bidder shall use only certified DBEs included in the "Directory of Certified Disadvantaged Business Enterprises" (hereinafter referred to as the "DBE Directory"), which is contained in the electronic file entitled "DBE BIN." The DBE BIN file for the letting can be found on and can be downloaded from the electronic bidding service web site, *Bid Express* (see Section 6 below).

Failure to provide all information required in the electronic bid may result in the contract being awarded to the next lowest responsible bidder.

The DBE BIN file listed for the letting must be downloaded for each particular letting because it is the data source for the DBEs listed in the DBE Directory designated for use in the letting. ALL DBE data such as Name, Company ID, and Address must be selected from drop-down lists provided by the DBE BIN file. If the DBE BIN file is not downloaded, no data for the drop-down lists will be available.

EXHIBIT 7 - FEDERAL AID SPECIFICATIONS AND FORMS

The following information must be selected or entered in the electronic bid:

- A. The names and addresses of certified DBEs whose services or materials will be used in the contract.
- B. Work Type and Work Code selected from a drop-down list. When one of these is selected, the other will be filled in automatically.
- C. An Item of work, approximate Quantity of work to be performed or materials to be supplied, Unit (of measurement), Unit Price, and the extended dollar amount of participation by each DBE listed.
 - (1) Item: The Item is the bid item with which the DBE will be associated and must be selected from the Schedule of (Bid) Items found in the drop-down list. If the proposed work is for only a portion of an Item of work (i.e. hauling of materials, tying of reinforced steel, etc.) an adequate description of this work shall be included in the Note block.
 - (2) Quantity, Unit, & Unit Price: Initially when an Item is selected, the contract quantity, unit, and the bidder's unit price and extension will appear. If the proposed work is for only a portion of an item as described in (1) above, then the Quantity, Unit Price and /or Extension shall be changed to reflect the actual amount of work committed to the DBE. The Unit (of measurement) cannot be changed.
- D. The bidder must also submit a copy of a signed statement or quote from each of the DBEs listed in the DBE List folder of the electronic bid. The signed statements or quotes should verify the items, quantities, units, unit prices, and dollar values listed in the DBE List folder of the electronic bid. **COPIES OF THE SIGNED STATEMENTS MUST BE SUBMITTED TO THE SCDOT CONTRACT ADMINISTRATION OFFICE WITHIN SIX (6) CALENDAR DAYS OF THE BID LETTING.** The Department will accept facsimiles of the verified statements with the caveat that the bidder must furnish the original document to the SCDOT upon request.

3. GOOD FAITH EFFORTS REQUIREMENTS

- A. Requirements for Submission for Approval of a Good Faith Effort. If the bidder does not meet the DBE contract goal through the DBE committals submitted with the electronic bid, the bidder may submit additional information to satisfy the SCDOT that good faith efforts have been made by the bidder in attempting to meet the DBE contract goal. **THIS INFORMATION MUST BE FURNISHED TO THE SCDOT CONTRACT ADMINISTRATION OFFICE IN WRITING WITHIN THREE (3) DAYS OF THE LETTING.** One complete set and five copies of this information must be received in the office of the Contracts Engineer no later than 12:00 noon of the third day following the letting. Where the information submitted includes repetitious solicitation letters, it will be acceptable to submit a sample representative letter along with the list of the firms being solicited. The documented efforts listed in item (C.) below are some of items the SCDOT will consider in evaluating the bidder's good faith efforts. The documentation may include written subcontractor quotations, telephone log notations of verbal quotations, or other types of quotation documents.
- B. Failure to Submit Required Material. If the bidder fails to provide this information by the deadline, the SCDOT may impose one or more of the following sanctions:
 - (1) Disqualification of the bidder and any affiliated companies from further bidding for a period of time not to exceed 90 days from the date of disqualification as established in notification by certified mail;
 - (2) Disqualification of the bidder and any affiliated companies for award of all contracts for which bids have been received and opened; or,

EXHIBIT 7 - FEDERAL AID SPECIFICATIONS AND FORMS

- (3) Disqualification of the bidder from the contract in question.
- C. Evaluation of a Good Faith Effort. The SCDOT may consider the following factors in judging whether or not the bidder made adequate and acceptable good faith efforts to meet the DBE contract goal:
- (1) Did the bidder attend any pre-bid meetings that were scheduled by the SCDOT to inform DBEs of subcontracting opportunities?
 - (2) Did the bidder provide solicitations through all reasonable and available means. For example: posting a request for quotes from DBE subcontractors on the SCDOT Construction Extranet webpage, or advertising in newspapers owned by and targeted toward DBEs at least 10 days prior to the letting, or providing written notice to all DBE's listed in the SCDOT DBE Directory that specialize in the areas of work in which the bidder will be subcontracting.
 - (3) Did the bidder follow-up initial solicitations of interests by contacting DBEs to determine with certainty whether they were interested or not? If a reasonable amount of DBEs in the area of work do not provide an intent to quote, or there are no DBEs that specialize in the area of work to be subcontracted, did the bidder call the SCDOT Office of DBE Program Development to give notification of the bidder's inability to obtain DBE quotes?
 - (4) Did the bidder select portions of the work to be performed by DBEs in order to increase the likelihood of meeting the contract goal? This includes, where appropriate, breaking out contract items of work into economically feasible units to facilitate DBE participation, even when the bidder might otherwise perform these items of work with its own forces.
 - (5) Did the bidder provide interested DBEs with adequate and timely information about the plans, specifications, and requirements of the contract?
 - (6) Did the bidder negotiate in good faith with interested DBEs, or reject them as unqualified without sound reasons based on a thorough investigation of their capabilities? Any rejection should be noted in writing with a description as to why an agreement could not be reached. The fact that the bidder has the ability or desire to perform the work with its own forces will not be considered as sound reason for rejecting a DBE's quote.
 - (7) Was a quote received from an interested DBE, but rejected as unacceptable because it was not the lowest quote received? The fact that the DBE's quote is not the lowest quote received will not in itself be considered a sound reason for rejecting the quote.
 - (8) Did the bidder specifically negotiate with non-DBE subcontractors to assume part of the responsibility to meet the contract goal when the work to be sublet includes potential for DBE participation?
 - (9) Did the bidder make any efforts and/or offer any assistance to interested DBEs in obtaining the necessary equipment, supplies, materials, insurance, and /or bonding to satisfy the work for items in the bid proposal?
 - (10) Any other evidence that the bidder submits which demonstrates that the bidder has made reasonable good faith efforts to include DBE participation.
 - (11) The DBE commitments submitted by all other bidders.

In the event one bidder is the apparent low bidder on more than one project located in the same geographical area in the same letting, the SCDOT will consider allowing the bidder to combine DBE participation as a part of the good faith effort, as long as the total of the DBE contract goals of all projects is achieved.

Nothing in this provision shall be construed to require the bidder to accept unreasonable quotes in order to satisfy DBE contract goals.

4. DETERMINATION AND RECONSIDERATION PROCEDURES

After the letting, the SCDOT will determine whether or not the low bidder has met the DBE contract goal or made good faith efforts to meet the goal. If the SCDOT determines that the low bidder failed to meet the goal and did not demonstrate a good faith effort to meet the goal, the SCDOT will notify

EXHIBIT 7 - FEDERAL AID SPECIFICATIONS AND FORMS

the low bidder of its determination in writing. The low bidder may request a reconsideration of this determination.

The bidder must make a request for reconsideration in writing within two (2) calendar days of receipt of the determination. Within six (6) calendar days of receipt of the determination, the bidder must provide written documentation to SCDOT Director of Construction supporting its position.

The State Highway Engineer will designate an official who did not take part in the original determination (hereinafter referred to as the "Reconsideration Official"), to reconsider the bidder's DBE commitment or good faith efforts. The Reconsideration Official will contact the bidder and schedule a meeting. The Reconsideration Official will make reasonable efforts to accommodate the bidder's schedule; however, if the bidder is unavailable or not prepared for a hearing within ten (10) calendar days of receipt of the SCDOT original written determination, the bidder's reconsideration rights will be considered to have been waived.

The meeting will be held at the SCDOT Headquarters Building, 955 Park Street, Columbia, South Carolina. The bidder will be allowed up to two hours to present written or oral evidence supporting its position.

The Reconsideration Official will issue a written report to the State Highway Engineer. The SCDOT shall not award the contract until the State Highway Engineer issues a decision or the bidder waives its reconsideration right either through failure to request reconsideration or failure to be available for the meeting.

5. CONSEQUENCES OF FAILURE TO COMPLY WITH DBE PROVISIONS

Failure on the part of the bidder to meet the DBE contract goal or to demonstrate good faith efforts to meet the DBE contract goal may result in the bid being declared non-responsive, and the award being made to the next lowest responsible bidder. The SCDOT also reserves the right to reject all bids.

6. DIRECTORY OF CERTIFIED DISADVANTAGED BUSINESS ENTERPRISES

The electronic DBE BIN file found on the electronic bidding service website, *Bid Express*, contains data from the "Directory of Certified Disadvantaged Business Enterprises" approved for use in each particular letting. **The file must be downloaded for each letting because the directory approved for use in each letting may differ.** The bidder is advised that this directory pertains only to DBE certification and not to qualifications. It is the bidder's responsibility to determine the actual capabilities and/or limitations of the certified DBE firms.

In meeting the DBE contract goal, the bidder shall use only DBEs that are included in the DBE Directory contained in the DBE BIN file current for the month the bid is submitted. The bidder may only count toward the DBE goal work in the areas for which the DBE has been certified, unless prior written approval from the SCDOT is obtained. The bidder and the DBE must jointly apply to the SCDOT's Director of Construction for approval of work in an area of work other than that in which the DBE has been certified. The requested work must be in an area related to the area of work in which the DBE has been certified. Such request must be submitted in writing to the Director of Construction no later than ten (10) days prior to the date of the letting. The Director of Construction has the right to approve or disapprove the request. The Director of Construction will give the bidder and the DBE written notice of his decision no later than five (5) days prior to the date on which bids are received. If approved, a copy of the written approval must accompany the submission of the subcontractor's quote.

Certification of a DBE for work in a certain area of work or approval to perform work in a related area shall not constitute a guarantee that the DBE will successfully perform the work or that the work will be performed completely. Such certification or approval shall only imply that the successful completion of the work by the DBE can count toward satisfying the DBE contract goal in accordance with the counting rules set forth in 49 CFR Part 26 (see Section 4 of the DBE Supplemental Specifications.)

The bidder may print a copy of the DBE Directory from the SCDOT web page at www.scdot.org under "Doing Business with SCDOT."

7. ADDITIONAL DBE PARTICIPATION

The bidder is strongly encouraged to obtain the maximum amount of DBE participation feasible on the contract. Any DBE participation in excess of the DBE contract goal shall also be included in the Quarterly Reports.

8. CONTRACTOR'S RESPONSIBILITY TO REPORT BIDDER INFORMATION

The Bidder should keep a list of all subcontractors (DBE or non-DBE) who bid or quoted for subcontracts on this project. As a condition to prequalification or renewal of prequalification, Contractors must submit the names and addresses of all firms (DBE and non-DBE) who quoted the Contractor for subcontracts on SCDOT projects throughout the course of the previous year.

Subcontractors should also keep a list of second tier subcontractors who bid or quote on second tier subcontracts. As a condition to approval as a subcontractor, SCDOT will require a subcontractor to submit, or have submitted within the previous year, the names and addresses of all firms (DBE and non-DBE) who quoted the subcontractor for second tier subcontracts on SCDOT projects throughout the course of the previous year. A subcontractor will not be approved for work on a SCDOT project until the subcontractor has submitted this information.

REQUIRED CONTRACT PROVISIONS FEDERAL-AID CONSTRUCTION CONTRACTS

- I. General
- II. Nondiscrimination
- III. Nonsegregated Facilities
- IV. Davis-Bacon and Related Act Provisions
- V. Contract Work Hours and Safety Standards Act Provisions
- VI. Subletting or Assigning the Contract
- VII. Safety: Accident Prevention
- VIII. False Statements Concerning Highway Projects
- IX. Implementation of Clean Air Act and Federal Water Pollution Control Act
- X. Compliance with Governmentwide Suspension and Debarment Requirements
- XI. Certification Regarding Use of Contract Funds for Lobbying

ATTACHMENTS

A. Employment and Materials Preference for Appalachian Development Highway System or Appalachian Local Access Road Contracts (included in Appalachian contracts only)

I. GENERAL

1. Form FHWA-1273 must be physically incorporated in each construction contract funded under Title 23 (excluding emergency contracts solely intended for debris removal). The contractor (or subcontractor) must insert this form in each subcontract and further require its inclusion in all lower tier subcontracts (excluding purchase orders, rental agreements and other agreements for supplies or services).

The applicable requirements of Form FHWA-1273 are incorporated by reference for work done under any purchase order, rental agreement or agreement for other services. The prime contractor shall be responsible for compliance by any subcontractor, lower-tier subcontractor or service provider.

Form FHWA-1273 must be included in all Federal-aid design-build contracts, in all subcontracts and in lower tier subcontracts (excluding subcontracts for design services, purchase orders, rental agreements and other agreements for supplies or services). The design-builder shall be responsible for compliance by any subcontractor, lower-tier subcontractor or service provider.

Contracting agencies may reference Form FHWA-1273 in bid proposal or request for proposal documents, however, the Form FHWA-1273 must be physically incorporated (not referenced) in all contracts, subcontracts and lower-tier subcontracts (excluding purchase orders, rental agreements and other agreements for supplies or services related to a construction contract).

2. Subject to the applicability criteria noted in the following sections, these contract provisions shall apply to all work performed on the contract by the contractor's own organization and with the assistance of workers under the contractor's immediate superintendence and to all work performed on the contract by piecework, station work, or by subcontract.

3. A breach of any of the stipulations contained in these Required Contract Provisions may be sufficient grounds for withholding of progress payments, withholding of final payment, termination of the contract, suspension / debarment or any other action determined to be appropriate by the contracting agency and FHWA.

4. Selection of Labor: During the performance of this contract, the contractor shall not use convict labor for any purpose within the limits of a construction project on a Federal-aid highway unless it is

labor performed by convicts who are on parole, supervised release, or probation. The term Federal-aid highway does not include roadways functionally classified as local roads or rural minor collectors.

II. NONDISCRIMINATION

The provisions of this section related to 23 CFR Part 230 are applicable to all Federal-aid construction contracts and to all related construction subcontracts of \$10,000 or more. The provisions of 23 CFR Part 230 are not applicable to material supply, engineering, or architectural service contracts.

In addition, the contractor and all subcontractors must comply with the following policies: Executive Order 11246, 41 CFR 60, 29 CFR 1625-1627, Title 23 USC Section 140, the Rehabilitation Act of 1973, as amended (29 USC 794), Title VI of the Civil Rights Act of 1964, as amended, and related regulations including 49 CFR Parts 21, 26 and 27; and 23 CFR Parts 200, 230, and 633.

The contractor and all subcontractors must comply with: the requirements of the Equal Opportunity Clause in 41 CFR 60-1.4(b) and, for all construction contracts exceeding \$10,000, the Standard Federal Equal Employment Opportunity Construction Contract Specifications in 41 CFR 60-4.3.

Note: The U.S. Department of Labor has exclusive authority to determine compliance with Executive Order 11246 and the policies of the Secretary of Labor including 41 CFR 60, and 29 CFR 1625-1627. The contracting agency and the FHWA have the authority and the responsibility to ensure compliance with Title 23 USC Section 140, the Rehabilitation Act of 1973, as amended (29 USC 794), and Title VI of the Civil Rights Act of 1964, as amended, and related regulations including 49 CFR Parts 21, 26 and 27; and 23 CFR Parts 200, 230, and 633.

The following provision is adopted from 23 CFR 230, Appendix A, with appropriate revisions to conform to the U.S. Department of Labor (US DOL) and FHWA requirements.

1. Equal Employment Opportunity: Equal employment opportunity (EEO) requirements not to discriminate and to take affirmative action to assure equal opportunity as set forth under laws, executive orders, rules, regulations (28 CFR 35, 29 CFR 1630, 29 CFR 1625-1627, 41 CFR 60 and 49 CFR 27) and orders of the Secretary of Labor as modified by the provisions prescribed herein, and imposed pursuant to 23 U.S.C. 140 shall constitute the EEO and specific affirmative action standards for the contractor's project activities under this contract. The provisions of the Americans with Disabilities Act of 1990 (42 U.S.C. 12101 et seq.) set forth under 28 CFR 35 and 29 CFR 1630 are incorporated by reference in this contract. In the execution of this contract, the contractor agrees to comply with the following minimum specific requirement activities of EEO:

a. The contractor will work with the contracting agency and the Federal Government to ensure that it has made every good faith effort to provide equal opportunity with respect to all of its terms and conditions of employment and in their review of activities under the contract.

b. The contractor will accept as its operating policy the following statement:

"It is the policy of this Company to assure that applicants are employed, and that employees are treated during employment, without regard to their race, religion, sex, color, national origin, age or disability. Such action shall include: employment, upgrading, demotion, or transfer; recruitment or recruitment advertising; layoff or termination; rates of pay or other forms of compensation; and selection for training, including apprenticeship, pre-apprenticeship, and/or on-the-job training."

2. EEO Officer: The contractor will designate and make known to the contracting officers an EEO Officer who will have the responsibility for and must be capable of effectively administering and promoting an active EEO program and who must be assigned adequate authority and responsibility to do so.

3. Dissemination of Policy: All members of the contractor's staff who are authorized to hire, supervise, promote, and discharge employees, or who recommend such action, or who are substantially involved in such action, will be made fully cognizant of, and will implement, the contractor's EEO policy and contractual responsibilities to provide EEO in each grade and classification of employment. To ensure that the above agreement will be met, the following actions will be taken as a minimum:

a. Periodic meetings of supervisory and personnel office employees will be conducted before the start of work and then not less often than once every six months, at which time the contractor's EEO policy and its implementation will be reviewed and explained. The meetings will be conducted by the EEO Officer.

b. All new supervisory or personnel office employees will be given a thorough indoctrination by the EEO Officer, covering all major aspects of the contractor's EEO obligations within thirty days following their reporting for duty with the contractor.

c. All personnel who are engaged in direct recruitment for the project will be instructed by the EEO Officer in the contractor's procedures for locating and hiring minorities and women.

d. Notices and posters setting forth the contractor's EEO policy will be placed in areas readily accessible to employees, applicants for employment and potential employees.

e. The contractor's EEO policy and the procedures to implement such policy will be brought to the attention of employees by means of meetings, employee handbooks, or other appropriate means.

4. Recruitment: When advertising for employees, the contractor will include in all advertisements for employees the notation: "An Equal Opportunity Employer." All such advertisements will be placed in publications having a large circulation among minorities and women in the area from which the project work force would normally be derived.

a. The contractor will, unless precluded by a valid bargaining agreement, conduct systematic and direct recruitment through public and private employee referral sources likely to yield qualified minorities and women. To meet this requirement, the contractor will identify sources of potential minority group employees, and establish with such identified sources procedures whereby minority and women applicants may be referred to the contractor for employment consideration.

b. In the event the contractor has a valid bargaining agreement providing for exclusive hiring hall referrals, the contractor is

expected to observe the provisions of that agreement to the extent that the system meets the contractor's compliance with EEO contract provisions. Where implementation of such an agreement has the effect of discriminating against minorities or women, or obligates the contractor to do the same, such implementation violates Federal nondiscrimination provisions.

c. The contractor will encourage its present employees to refer minorities and women as applicants for employment. Information and procedures with regard to referring such applicants will be discussed with employees.

5. Personnel Actions: Wages, working conditions, and employee benefits shall be established and administered, and personnel actions of every type, including hiring, upgrading, promotion, transfer, demotion, layoff, and termination, shall be taken without regard to race, color, religion, sex, national origin, age or disability. The following procedures shall be followed:

a. The contractor will conduct periodic inspections of project sites to insure that working conditions and employee facilities do not indicate discriminatory treatment of project site personnel.

b. The contractor will periodically evaluate the spread of wages paid within each classification to determine any evidence of discriminatory wage practices.

c. The contractor will periodically review selected personnel actions in depth to determine whether there is evidence of discrimination. Where evidence is found, the contractor will promptly take corrective action. If the review indicates that the discrimination may extend beyond the actions reviewed, such corrective action shall include all affected persons.

d. The contractor will promptly investigate all complaints of alleged discrimination made to the contractor in connection with its obligations under this contract, will attempt to resolve such complaints, and will take appropriate corrective action within a reasonable time. If the investigation indicates that the discrimination may affect persons other than the complainant, such corrective action shall include such other persons. Upon completion of each investigation, the contractor will inform every complainant of all of their avenues of appeal.

6. Training and Promotion:

a. The contractor will assist in locating, qualifying, and increasing the skills of minorities and women who are applicants for employment or current employees. Such efforts should be aimed at developing full journey level status employees in the type of trade or job classification involved.

b. Consistent with the contractor's work force requirements and as permissible under Federal and State regulations, the contractor shall make full use of training programs, i.e., apprenticeship, and on-the-job training programs for the geographical area of contract performance. In the event a special provision for training is provided under this contract, this subparagraph will be superseded as indicated in the special provision. The contracting agency may reserve training positions for persons who receive welfare assistance in accordance with 23 U.S.C. 140(a).

c. The contractor will advise employees and applicants for employment of available training programs and entrance requirements for each.

d. The contractor will periodically review the training and promotion potential of employees who are minorities and women and will encourage eligible employees to apply for such training and promotion.

7. Unions: If the contractor relies in whole or in part upon unions as a source of employees, the contractor will use good faith efforts to obtain the cooperation of such unions to increase opportunities for minorities and women. Actions by the contractor, either directly or through a contractor's association acting as agent, will include the procedures set forth below:

a. The contractor will use good faith efforts to develop, in cooperation with the unions, joint training programs aimed toward qualifying more minorities and women for membership in the unions and increasing the skills of minorities and women so that they may qualify for higher paying employment.

b. The contractor will use good faith efforts to incorporate an EEO clause into each union agreement to the end that such union will be contractually bound to refer applicants without regard to their race, color, religion, sex, national origin, age or disability.

c. The contractor is to obtain information as to the referral practices and policies of the labor union except that to the extent such information is within the exclusive possession of the labor union and such labor union refuses to furnish such information to the contractor, the contractor shall so certify to the contracting agency and shall set forth what efforts have been made to obtain such information.

d. In the event the union is unable to provide the contractor with a reasonable flow of referrals within the time limit set forth in the collective bargaining agreement, the contractor will, through independent recruitment efforts, fill the employment vacancies without regard to race, color, religion, sex, national origin, age or disability; making full efforts to obtain qualified and/or qualifiable minorities and women. The failure of a union to provide sufficient referrals (even though it is obligated to provide exclusive referrals under the terms of a collective bargaining agreement) does not relieve the contractor from the requirements of this paragraph. In the event the union referral practice prevents the contractor from meeting the obligations pursuant to Executive Order 11246, as amended, and these special provisions, such contractor shall immediately notify the contracting agency.

8. Reasonable Accommodation for Applicants / Employees with Disabilities: The contractor must be familiar with the requirements for and comply with the Americans with Disabilities Act and all rules and regulations established there under. Employers must provide reasonable accommodation in all employment activities unless to do so would cause an undue hardship.

9. Selection of Subcontractors, Procurement of Materials and Leasing of Equipment: The contractor shall not discriminate on the grounds of race, color, religion, sex, national origin, age or disability in the selection and retention of subcontractors, including procurement of materials and leases of equipment. The contractor shall take all necessary and reasonable steps to ensure nondiscrimination in the administration of this contract.

a. The contractor shall notify all potential subcontractors and suppliers and lessors of their EEO obligations under this contract.

b. The contractor will use good faith efforts to ensure subcontractor compliance with their EEO obligations.

10. Assurance Required by 49 CFR 26.13(b):

a. The requirements of 49 CFR Part 26 and the State DOT's U.S. DOT-approved DBE program are incorporated by reference.

b. The contractor or subcontractor shall not discriminate on the basis of race, color, national origin, or sex in the performance of this contract. The contractor shall carry out applicable requirements of 49 CFR Part 26 in the award and administration of DOT-assisted contracts. Failure by the contractor to carry out these requirements is a material breach of this contract, which may result in the termination of this contract or such other remedy as the contracting agency deems appropriate.

11. Records and Reports: The contractor shall keep such records as necessary to document compliance with the EEO requirements. Such records shall be retained for a period of three years following the date of the final payment to the contractor for all contract work and shall be available at reasonable times and places for inspection by authorized representatives of the contracting agency and the FHWA.

a. The records kept by the contractor shall document the following:

(1) The number and work hours of minority and non-minority group members and women employed in each work classification on the project;

(2) The progress and efforts being made in cooperation with unions, when applicable, to increase employment opportunities for minorities and women; and

(3) The progress and efforts being made in locating, hiring, training, qualifying, and upgrading minorities and women;

b. The contractors and subcontractors will submit an annual report to the contracting agency each July for the duration of the project, indicating the number of minority, women, and non-minority group employees currently engaged in each work classification required by the contract work. This information is to be reported on [Form FHWA-1391](#). The staffing data should represent the project work force on board in all or any part of the last payroll period preceding the end of July. If on-the-job training is being required by special provision, the contractor will be required to collect and report training data. The employment data should reflect the work force on board during all or any part of the last payroll period preceding the end of July.

III. NONSEGREGATED FACILITIES

This provision is applicable to all Federal-aid construction contracts and to all related construction subcontracts of \$10,000 or more.

The contractor must ensure that facilities provided for employees are provided in such a manner that segregation on the basis of race, color, religion, sex, or national origin cannot result. The contractor may neither require such segregated use by written or oral policies nor tolerate such use by employee custom. The contractor's obligation extends further to ensure that its employees are not assigned to perform their services at any location, under the contractor's control, where the facilities are

segregated. The term "facilities" includes waiting rooms, work areas, restaurants and other eating areas, time clocks, restrooms, washrooms, locker rooms, and other storage or dressing areas, parking lots, drinking fountains, recreation or entertainment areas, transportation, and housing provided for employees. The contractor shall provide separate or single-user restrooms and necessary dressing or sleeping areas to assure privacy between sexes.

IV. Davis-Bacon and Related Act Provisions

This section is applicable to all Federal-aid construction projects exceeding \$2,000 and to all related subcontracts and lower-tier subcontracts (regardless of subcontract size). The requirements apply to all projects located within the right-of-way of a roadway that is functionally classified as Federal-aid highway. This excludes roadways functionally classified as local roads or rural minor collectors, which are exempt. Contracting agencies may elect to apply these requirements to other projects.

The following provisions are from the U.S. Department of Labor regulations in 29 CFR 5.5 "Contract provisions and related matters" with minor revisions to conform to the FHWA-1273 format and FHWA program requirements.

1. Minimum wages

a. All laborers and mechanics employed or working upon the site of the work, will be paid unconditionally and not less often than once a week, and without subsequent deduction or rebate on any account (except such payroll deductions as are permitted by regulations issued by the Secretary of Labor under the Copeland Act (29 CFR part 3)), the full amount of wages and bona fide fringe benefits (or cash equivalents thereof) due at time of payment computed at rates not less than those contained in the wage determination of the Secretary of Labor which is attached hereto and made a part hereof, regardless of any contractual relationship which may be alleged to exist between the contractor and such laborers and mechanics.

Contributions made or costs reasonably anticipated for bona fide fringe benefits under section 1(b)(2) of the Davis-Bacon Act on behalf of laborers or mechanics are considered wages paid to such laborers or mechanics, subject to the provisions of paragraph 1.d. of this section; also, regular contributions made or costs incurred for more than a weekly period (but not less often than quarterly) under plans, funds, or programs which cover the particular weekly period, are deemed to be constructively made or incurred during such weekly period. Such laborers and mechanics shall be paid the appropriate wage rate and fringe benefits on the wage determination for the classification of work actually performed, without regard to skill, except as provided in 29 CFR 5.5(a)(4). Laborers or mechanics performing work in more than one classification may be compensated at the rate specified for each classification for the time actually worked therein: Provided, That the employer's payroll records accurately set forth the time spent in each classification in which work is performed. The wage determination (including any additional classification and wage rates conformed under paragraph 1.b. of this section) and the Davis-Bacon poster (WH-1321) shall be posted at all times by the contractor and its subcontractors at the site of the work in a prominent and accessible place where it can be easily seen by the workers.

b. (1) The contracting officer shall require that any class of laborers or mechanics, including helpers, which is not listed in the wage determination and which is to be employed under the contract shall be classified in conformance with the wage determination. The contracting officer shall approve an additional classification and wage rate and fringe benefits therefore only when the following criteria have been met:

(i) The work to be performed by the classification requested is not performed by a classification in the wage determination; and

(ii) The classification is utilized in the area by the construction industry; and

(iii) The proposed wage rate, including any bona fide fringe benefits, bears a reasonable relationship to the wage rates contained in the wage determination.

(2) If the contractor and the laborers and mechanics to be employed in the classification (if known), or their representatives, and the contracting officer agree on the classification and wage rate (including the amount designated for fringe benefits where appropriate), a report of the action taken shall be sent by the contracting officer to the Administrator of the Wage and Hour Division, Employment Standards Administration, U.S. Department of Labor, Washington, DC 20210. The Administrator, or an authorized representative, will approve, modify, or disapprove every additional classification action within 30 days of receipt and so advise the contracting officer or will notify the contracting officer within the 30-day period that additional time is necessary.

(3) In the event the contractor, the laborers or mechanics to be employed in the classification or their representatives, and the contracting officer do not agree on the proposed classification and wage rate (including the amount designated for fringe benefits, where appropriate), the contracting officer shall refer the questions, including the views of all interested parties and the recommendation of the contracting officer, to the Wage and Hour Administrator for determination. The Wage and Hour Administrator, or an authorized representative, will issue a determination within 30 days of receipt and so advise the contracting officer or will notify the contracting officer within the 30-day period that additional time is necessary.

(4) The wage rate (including fringe benefits where appropriate) determined pursuant to paragraphs 1.b.(2) or 1.b.(3) of this section, shall be paid to all workers performing work in the classification under this contract from the first day on which work is performed in the classification.

c. Whenever the minimum wage rate prescribed in the contract for a class of laborers or mechanics includes a fringe benefit which is not expressed as an hourly rate, the contractor shall either pay the benefit as stated in the wage determination or shall pay another bona fide fringe benefit or an hourly cash equivalent thereof.

d. If the contractor does not make payments to a trustee or other third person, the contractor may consider as part of the wages of any laborer or mechanic the amount of any costs reasonably anticipated in providing bona fide fringe benefits under a plan or program, Provided, That the Secretary of Labor has found, upon the written request of the contractor, that the applicable standards of the Davis-Bacon Act have been met. The Secretary of Labor may require the contractor to set aside in a separate account assets for the meeting of obligations under the plan or program.

2. Withholding

The contracting agency shall upon its own action or upon written request of an authorized representative

of the Department of Labor, withhold or cause to be withheld from the contractor under this contract, or any other Federal contract with the same prime contractor, or any other federally-assisted contract subject to Davis-Bacon prevailing wage requirements, which is held by the same prime contractor, so much of the accrued payments or advances as may be considered necessary to pay laborers and mechanics, including apprentices, trainees, and helpers, employed by the contractor or any subcontractor the full amount of wages required by the contract. In the event of failure to pay any laborer or mechanic, including any apprentice, trainee, or helper, employed or working on the site of the work, all or part of the wages required by the contract, the contracting agency may, after written notice to the contractor, take such action as may be necessary to cause the suspension of any further payment, advance, or guarantee of funds until such violations have ceased.

3. Payrolls and basic records

a. Payrolls and basic records relating thereto shall be maintained by the contractor during the course of the work and preserved for a period of three years thereafter for all laborers and mechanics working at the site of the work. Such records shall contain the name, address, and social security number of each such worker, his or her correct classification, hourly rates of wages paid (including rates of contributions or costs anticipated for bona fide fringe benefits or cash equivalents thereof of the types described in section 1(b)(2)(B) of the Davis-Bacon Act), daily and weekly number of hours worked, deductions made and actual wages paid. Whenever the Secretary of Labor has found under 29 CFR 5.5(a)(1)(iv) that the wages of any laborer or mechanic include the amount of any costs reasonably anticipated in providing benefits under a plan or program described in section 1(b)(2)(B) of the Davis-Bacon Act, the contractor shall maintain records which show that the commitment to provide such benefits is enforceable, that the plan or program is financially responsible, and that the plan or program has been communicated in writing to the laborers or mechanics affected, and records which show the costs anticipated or the actual cost incurred in providing such benefits. Contractors employing apprentices or trainees under approved programs shall maintain written evidence of the registration of apprenticeship programs and certification of trainee programs, the registration of the apprentices and trainees, and the ratios and wage rates prescribed in the applicable programs.

b. (1) The contractor shall submit weekly for each week in which any contract work is performed a copy of all payrolls to the contracting agency. The payrolls submitted shall set out accurately and completely all of the information required to be maintained under 29 CFR 5.5(a)(3)(i), except that full social security numbers and home addresses shall not be included on weekly transmittals. Instead the payrolls shall only need to include an individually identifying number for each employee (e.g. , the last four digits of the employee's social security number). The required weekly payroll information may be submitted in any form desired. Optional Form WH-347 is available for this purpose from the Wage and Hour Division Web site at <http://www.dol.gov/esa/whd/forms/wh347instr.htm> or its successor site. The prime contractor is responsible for the submission of copies of payrolls by all subcontractors. Contractors and subcontractors shall maintain the full social security number and current address of each covered worker, and shall provide them upon request to the contracting agency for transmission to the State DOT, the FHWA or the Wage and Hour Division of the Department of Labor for purposes of an investigation or audit of compliance with prevailing wage requirements. It is not a violation of this section for a prime contractor to require a subcontractor to provide addresses and social security numbers to the prime contractor for its own records, without weekly submission to the contracting agency..

(2) Each payroll submitted shall be accompanied by a "Statement of Compliance," signed by the contractor or subcontractor or his or her agent who pays or supervises the payment of the persons employed under the contract and shall certify the following:

(i) That the payroll for the payroll period contains the information required to be provided under §5.5 (a)(3)(ii) of Regulations, 29 CFR part 5, the appropriate information is being maintained under §5.5 (a)(3)(i) of Regulations, 29 CFR part 5, and that such information is correct and complete;

(ii) That each laborer or mechanic (including each helper, apprentice, and trainee) employed on the contract during the payroll period has been paid the full weekly wages earned, without rebate, either directly or indirectly, and that no deductions have been made either directly or indirectly from the full wages earned, other than permissible deductions as set forth in Regulations, 29 CFR part 3;

(iii) That each laborer or mechanic has been paid not less than the applicable wage rates and fringe benefits or cash equivalents for the classification of work performed, as specified in the applicable wage determination incorporated into the contract.

(3) The weekly submission of a properly executed certification set forth on the reverse side of Optional Form WH-347 shall satisfy the requirement for submission of the "Statement of Compliance" required by paragraph 3.b.(2) of this section.

(4) The falsification of any of the above certifications may subject the contractor or subcontractor to civil or criminal prosecution under section 1001 of title 18 and section 231 of title 31 of the United States Code.

c. The contractor or subcontractor shall make the records required under paragraph 3.a. of this section available for inspection, copying, or transcription by authorized representatives of the contracting agency, the State DOT, the FHWA, or the Department of Labor, and shall permit such representatives to interview employees during working hours on the job. If the contractor or subcontractor fails to submit the required records or to make them available, the FHWA may, after written notice to the contractor, the contracting agency or the State DOT, take such action as may be necessary to cause the suspension of any further payment, advance, or guarantee of funds. Furthermore, failure to submit the required records upon request or to make such records available may be grounds for debarment action pursuant to 29 CFR 5.12.

4. Apprentices and trainees

a. Apprentices (programs of the USDOL).

Apprentices will be permitted to work at less than the predetermined rate for the work they performed when they are employed pursuant to and individually registered in a bona fide apprenticeship program registered with the U.S. Department of Labor, Employment and Training Administration, Office of Apprenticeship Training, Employer and Labor Services, or with a State Apprenticeship Agency recognized by the Office, or if a person is employed in his or her first 90 days of probationary employment as an apprentice in such an apprenticeship program, who is not individually registered in the program, but who has been certified by the Office of

Apprenticeship Training, Employer and Labor Services or a State Apprenticeship Agency (where appropriate) to be eligible for probationary employment as an apprentice.

The allowable ratio of apprentices to journeymen on the job site in any craft classification shall not be greater than the ratio permitted to the contractor as to the entire work force under the registered program. Any worker listed on a payroll at an apprentice wage rate, who is not registered or otherwise employed as stated above, shall be paid not less than the applicable wage rate on the wage determination for the classification of work actually performed. In addition, any apprentice performing work on the job site in excess of the ratio permitted under the registered program shall be paid not less than the applicable wage rate on the wage determination for the work actually performed. Where a contractor is performing construction on a project in a locality other than that in which its program is registered, the ratios and wage rates (expressed in percentages of the journeyman's hourly rate) specified in the contractor's or subcontractor's registered program shall be observed.

Every apprentice must be paid at not less than the rate specified in the registered program for the apprentice's level of progress, expressed as a percentage of the journeymen hourly rate specified in the applicable wage determination. Apprentices shall be paid fringe benefits in accordance with the provisions of the apprenticeship program. If the apprenticeship program does not specify fringe benefits, apprentices must be paid the full amount of fringe benefits listed on the wage determination for the applicable classification. If the Administrator determines that a different practice prevails for the applicable apprentice classification, fringes shall be paid in accordance with that determination.

In the event the Office of Apprenticeship Training, Employer and Labor Services, or a State Apprenticeship Agency recognized by the Office, withdraws approval of an apprenticeship program, the contractor will no longer be permitted to utilize apprentices at less than the applicable predetermined rate for the work performed until an acceptable program is approved.

b. Trainees (programs of the USDOL).

Except as provided in 29 CFR 5.16, trainees will not be permitted to work at less than the predetermined rate for the work performed unless they are employed pursuant to and individually registered in a program which has received prior approval, evidenced by formal certification by the U.S. Department of Labor, Employment and Training Administration.

The ratio of trainees to journeymen on the job site shall not be greater than permitted under the plan approved by the Employment and Training Administration.

Every trainee must be paid at not less than the rate specified in the approved program for the trainee's level of progress, expressed as a percentage of the journeyman hourly rate specified in the applicable wage determination. Trainees shall be paid fringe benefits in accordance with the provisions of the trainee program. If the trainee program does not mention fringe benefits, trainees shall be paid the full amount of fringe benefits listed on the wage determination unless the Administrator of the Wage and Hour Division determines that there is an apprenticeship program associated with the corresponding journeyman wage rate on the wage determination which provides for less than full fringe benefits for apprentices. Any employee listed on the payroll at a trainee rate who is not registered and participating in a training plan approved by the Employment and Training Administration shall be paid not less than the applicable wage rate on the wage determination for the classification of work actually performed. In addition, any trainee performing work on the job site in excess of the ratio permitted under the registered program shall be paid not less than the applicable wage rate on the wage determination for the work actually performed.

In the event the Employment and Training Administration withdraws approval of a training program, the contractor will no longer be permitted to utilize trainees at less than the applicable predetermined rate for the work performed until an acceptable program is approved.

c. Equal employment opportunity. The utilization of apprentices, trainees and journeymen under this part shall be in conformity with the equal employment opportunity requirements of Executive Order 11246, as amended, and 29 CFR part 30.

d. Apprentices and Trainees (programs of the U.S. DOT).

Apprentices and trainees working under apprenticeship and skill training programs which have been certified by the Secretary of Transportation as promoting EEO in connection with Federal-aid highway construction programs are not subject to the requirements of paragraph 4 of this Section IV. The straight time hourly wage rates for apprentices and trainees under such programs will be established by the particular programs. The ratio of apprentices and trainees to journeymen shall not be greater than permitted by the terms of the particular program.

5. Compliance with Copeland Act requirements. The contractor shall comply with the requirements of 29 CFR part 3, which are incorporated by reference in this contract.

6. Subcontracts. The contractor or subcontractor shall insert Form FHWA-1273 in any subcontracts and also require the subcontractors to include Form FHWA-1273 in any lower tier subcontracts. The prime contractor shall be responsible for the compliance by any subcontractor or lower tier subcontractor with all the contract clauses in 29 CFR 5.5.

7. Contract termination: debarment. A breach of the contract clauses in 29 CFR 5.5 may be grounds for termination of the contract, and for debarment as a contractor and a subcontractor as provided in 29 CFR 5.12.

8. Compliance with Davis-Bacon and Related Act requirements. All rulings and interpretations of the Davis-Bacon and Related Acts contained in 29 CFR parts 1, 3, and 5 are herein incorporated by reference in this contract.

9. Disputes concerning labor standards. Disputes arising out of the labor standards provisions of this contract shall not be subject to the general disputes clause of this contract. Such disputes shall be resolved in accordance with the procedures of the Department of Labor set forth in 29 CFR parts 5, 6, and 7. Disputes within the meaning of this clause include disputes between the contractor (or any of its subcontractors) and the contracting agency, the U.S. Department of Labor, or the employees or their representatives.

10. Certification of eligibility.

a. By entering into this contract, the contractor certifies that neither it (nor he or she) nor any person or firm who has an interest in the contractor's firm is a person or firm ineligible to be awarded Government

contracts by virtue of section 3(a) of the Davis-Bacon Act or 29 CFR 5.12(a)(1).

b. No part of this contract shall be subcontracted to any person or firm ineligible for award of a Government contract by virtue of section 3(a) of the Davis-Bacon Act or 29 CFR 5.12(a)(1).

c. The penalty for making false statements is prescribed in the U.S. Criminal Code, 18 U.S.C. 1001.

V. CONTRACT WORK HOURS AND SAFETY STANDARDS ACT

The following clauses apply to any Federal-aid construction contract in an amount in excess of \$100,000 and subject to the overtime provisions of the Contract Work Hours and Safety Standards Act. These clauses shall be inserted in addition to the clauses required by 29 CFR 5.5(a) or 29 CFR 4.6. As used in this paragraph, the terms laborers and mechanics include watchmen and guards.

1. Overtime requirements. No contractor or subcontractor contracting for any part of the contract work which may require or involve the employment of laborers or mechanics shall require or permit any such laborer or mechanic in any workweek in which he or she is employed on such work to work in excess of forty hours in such workweek unless such laborer or mechanic receives compensation at a rate not less than one and one-half times the basic rate of pay for all hours worked in excess of forty hours in such workweek.

2. Violation; liability for unpaid wages; liquidated damages. In the event of any violation of the clause set forth in paragraph (1.) of this section, the contractor and any subcontractor responsible therefor shall be liable for the unpaid wages. In addition, such contractor and subcontractor shall be liable to the United States (in the case of work done under contract for the District of Columbia or a territory, to such District or to such territory), for liquidated damages. Such liquidated damages shall be computed with respect to each individual laborer or mechanic, including watchmen and guards, employed in violation of the clause set forth in paragraph (1.) of this section, in the sum of \$10 for each calendar day on which such individual was required or permitted to work in excess of the standard workweek of forty hours without payment of the overtime wages required by the clause set forth in paragraph (1.) of this section.

3. Withholding for unpaid wages and liquidated damages. The FHWA or the contracting agency shall upon its own action or upon written request of an authorized representative of the Department of Labor withhold or cause to be withheld, from any moneys payable on account of work performed by the contractor or subcontractor under any such contract or any other Federal contract with the same prime contractor, or any other federally-assisted contract subject to the Contract Work Hours and Safety Standards Act, which is held by the same prime contractor, such sums as may be determined to be necessary to satisfy any liabilities of such contractor or subcontractor for unpaid wages and liquidated damages as provided in the clause set forth in paragraph (2.) of this section.

4. Subcontracts. The contractor or subcontractor shall insert in any subcontracts the clauses set forth in paragraph (1.) through (4.) of this section and also a clause requiring the subcontractors to include these clauses in any lower tier subcontracts. The prime contractor shall be responsible for compliance by any subcontractor or lower tier subcontractor with the clauses set forth in paragraphs (1.) through (4.) of this section.

VI. SUBLETTING OR ASSIGNING THE CONTRACT

This provision is applicable to all Federal-aid construction contracts on the National Highway System.

1. The contractor shall perform with its own organization contract work amounting to not less than 30 percent (or a greater percentage if specified elsewhere in the contract) of the total original contract price, excluding any specialty items designated by the contracting agency. Specialty items may be performed by subcontract and the amount of any such specialty items performed may be deducted from the total original contract price before computing the amount of work required to be performed by the contractor's own organization (23 CFR 635.116).

a. The term "perform work with its own organization" refers to workers employed or leased by the prime contractor, and equipment owned or rented by the prime contractor, with or without operators. Such term does not include employees or equipment of a subcontractor or lower tier subcontractor, agents of the prime contractor, or any other assignees. The term may include payments for the costs of hiring leased employees from an employee leasing firm meeting all relevant Federal and State regulatory requirements. Leased employees may only be included in this term if the prime contractor meets all of the following conditions:

(1) the prime contractor maintains control over the supervision of the day-to-day activities of the leased employees;

(2) the prime contractor remains responsible for the quality of the work of the leased employees;

(3) the prime contractor retains all power to accept or exclude individual employees from work on the project; and

(4) the prime contractor remains ultimately responsible for the payment of predetermined minimum wages, the submission of payrolls, statements of compliance and all other Federal regulatory requirements.

b. "Specialty Items" shall be construed to be limited to work that requires highly specialized knowledge, abilities, or equipment not ordinarily available in the type of contracting organizations qualified and expected to bid or propose on the contract as a whole and in general are to be limited to minor components of the overall contract.

2. The contract amount upon which the requirements set forth in paragraph (1) of Section VI is computed includes the cost of material and manufactured products which are to be purchased or produced by the contractor under the contract provisions.

3. The contractor shall furnish (a) a competent superintendent or supervisor who is employed by the firm, has full authority to direct performance of the work in accordance with the contract requirements, and is in charge of all construction operations (regardless of who performs the work) and (b) such other of its own organizational resources (supervision, management, and engineering services) as the contracting officer determines is necessary to assure the performance of the contract.

4. No portion of the contract shall be sublet, assigned or otherwise disposed of except with the written consent of the contracting officer, or authorized representative, and such consent when given shall not be construed to relieve the contractor of any responsibility for the fulfillment of the contract. Written consent will be given only after the

contracting agency has assured that each subcontract is evidenced in writing and that it contains all pertinent provisions and requirements of the prime contract.

5. The 30% self-performance requirement of paragraph (1) is not applicable to design-build contracts; however, contracting agencies may establish their own self-performance requirements.

VII. SAFETY: ACCIDENT PREVENTION

This provision is applicable to all Federal-aid construction contracts and to all related subcontracts.

1. In the performance of this contract the contractor shall comply with all applicable Federal, State, and local laws governing safety, health, and sanitation (23 CFR 635). The contractor shall provide all safeguards, safety devices and protective equipment and take any other needed actions as it determines, or as the contracting officer may determine, to be reasonably necessary to protect the life and health of employees on the job and the safety of the public and to protect property in connection with the performance of the work covered by the contract.

2. It is a condition of this contract, and shall be made a condition of each subcontract, which the contractor enters into pursuant to this contract, that the contractor and any subcontractor shall not permit any employee, in performance of the contract, to work in surroundings or under conditions which are unsanitary, hazardous or dangerous to his/her health or safety, as determined under construction safety and health standards (29 CFR 1926) promulgated by the Secretary of Labor, in accordance with Section 107 of the Contract Work Hours and Safety Standards Act (40 U.S.C. 3704).

3. Pursuant to 29 CFR 1926.3, it is a condition of this contract that the Secretary of Labor or authorized representative thereof, shall have right of entry to any site of contract performance to inspect or investigate the matter of compliance with the construction safety and health standards and to carry out the duties of the Secretary under Section 107 of the Contract Work Hours and Safety Standards Act (40 U.S.C.3704).

VIII. FALSE STATEMENTS CONCERNING HIGHWAY PROJECTS

This provision is applicable to all Federal-aid construction contracts and to all related subcontracts.

In order to assure high quality and durable construction in conformity with approved plans and specifications and a high degree of reliability on statements and representations made by engineers, contractors, suppliers, and workers on Federal-aid highway projects, it is essential that all persons concerned with the project perform their functions as carefully, thoroughly, and honestly as possible. Willful falsification, distortion, or misrepresentation with respect to any facts related to the project is a violation of Federal law. To prevent any misunderstanding regarding the seriousness of these and similar acts, Form FHWA-1022 shall be posted on each Federal-aid highway project (23 CFR 635) in one or more places where it is readily available to all persons concerned with the project:

18 U.S.C. 1020 reads as follows:

"Whoever, being an officer, agent, or employee of the United States, or of any State or Territory, or whoever, whether a person, association, firm, or corporation, knowingly makes any false statement, false representation, or false report as to the character, quality, quantity, or cost of the material used or to be used, or the quantity or quality of the work performed or to be performed, or the cost thereof in connection with the submission of plans, maps, specifications, contracts, or costs of construction on any highway or

related project submitted for approval to the Secretary of Transportation; or

Whoever knowingly makes any false statement, false representation, false report or false claim with respect to the character, quality, quantity, or cost of any work performed or to be performed, or materials furnished or to be furnished, in connection with the construction of any highway or related project approved by the Secretary of Transportation; or

Whoever knowingly makes any false statement or false representation as to material fact in any statement, certificate, or report submitted pursuant to provisions of the Federal-aid Roads Act approved July 1, 1916, (39 Stat. 355), as amended and supplemented;

Shall be fined under this title or imprisoned not more than 5 years or both."

IX. IMPLEMENTATION OF CLEAN AIR ACT AND FEDERAL WATER POLLUTION CONTROL ACT

This provision is applicable to all Federal-aid construction contracts and to all related subcontracts.

By submission of this bid/proposal or the execution of this contract, or subcontract, as appropriate, the bidder, proposer, Federal-aid construction contractor, or subcontractor, as appropriate, will be deemed to have stipulated as follows:

1. That any person who is or will be utilized in the performance of this contract is not prohibited from receiving an award due to a violation of Section 508 of the Clean Water Act or Section 306 of the Clean Air Act.

2. That the contractor agrees to include or cause to be included the requirements of paragraph (1) of this Section X in every subcontract, and further agrees to take such action as the contracting agency may direct as a means of enforcing such requirements.

X. CERTIFICATION REGARDING DEBARMENT, SUSPENSION, INELIGIBILITY AND VOLUNTARY EXCLUSION

This provision is applicable to all Federal-aid construction contracts, design-build contracts, subcontracts, lower-tier subcontracts, purchase orders, lease agreements, consultant contracts or any other covered transaction requiring FHWA approval or that is estimated to cost \$25,000 or more – as defined in 2 CFR Parts 180 and 1200.

1. Instructions for Certification – First Tier Participants:

a. By signing and submitting this proposal, the prospective first tier participant is providing the certification set out below.

b. The inability of a person to provide the certification set out below will not necessarily result in denial of participation in this covered transaction. The prospective first tier participant shall submit an explanation of why it cannot provide the certification set out below. The certification or explanation will be considered in connection with the department or agency's determination whether to enter into this transaction. However, failure of the prospective first

tier participant to furnish a certification or an explanation shall disqualify such a person from participation in this transaction.

c. The certification in this clause is a material representation of fact upon which reliance was placed when the contracting agency determined to enter into this transaction. If it is later determined that the prospective participant knowingly rendered an erroneous certification, in addition to other remedies available to the Federal Government, the contracting agency may terminate this transaction for cause of default.

d. The prospective first tier participant shall provide immediate written notice to the contracting agency to whom this proposal is submitted if any time the prospective first tier participant learns that its certification was erroneous when submitted or has become erroneous by reason of changed circumstances.

e. The terms "covered transaction," "debarred," "suspended," "ineligible," "participant," "person," "principal," and "voluntarily excluded," as used in this clause, are defined in 2 CFR Parts 180 and 1200. "First Tier Covered Transactions" refers to any covered transaction between a grantee or subgrantee of Federal funds and a participant (such as the prime or general contract). "Lower Tier Covered Transactions" refers to any covered transaction under a First Tier Covered Transaction (such as subcontracts). "First Tier Participant" refers to the participant who has entered into a covered transaction with a grantee or subgrantee of Federal funds (such as the prime or general contractor). "Lower Tier Participant" refers any participant who has entered into a covered transaction with a First Tier Participant or other Lower Tier Participants (such as subcontractors and suppliers).

f. The prospective first tier participant agrees by submitting this proposal that, should the proposed covered transaction be entered into, it shall not knowingly enter into any lower tier covered transaction with a person who is debarred, suspended, declared ineligible, or voluntarily excluded from participation in this covered transaction, unless authorized by the department or agency entering into this transaction.

g. The prospective first tier participant further agrees by submitting this proposal that it will include the clause titled "Certification Regarding Debarment, Suspension, Ineligibility and Voluntary Exclusion-Lower Tier Covered Transactions," provided by the department or contracting agency, entering into this covered transaction, without modification, in all lower tier covered transactions and in all solicitations for lower tier covered transactions exceeding the \$25,000 threshold.

h. A participant in a covered transaction may rely upon a certification of a prospective participant in a lower tier covered transaction that is not debarred, suspended, ineligible, or voluntarily excluded from the covered transaction, unless it knows that the certification is erroneous. A participant is responsible for ensuring that its principals are not suspended, debarred, or otherwise ineligible to participate in covered transactions. To verify the eligibility of its principals, as well as the eligibility of any lower tier prospective participants, each participant may, but is not required to, check the Excluded Parties List System website (<https://www.epls.gov/>), which is compiled by the General Services Administration.

i. Nothing contained in the foregoing shall be construed to require the establishment of a system of records in order to render in good faith the certification required by this clause. The knowledge and information of the prospective participant is not required to exceed that which is normally possessed by a prudent person in the ordinary course of business dealings.

j. Except for transactions authorized under paragraph (f) of these instructions, if a participant in a covered transaction knowingly enters into a lower tier covered transaction with a person who is suspended, debarred, ineligible, or voluntarily excluded from participation in this transaction, in addition to other remedies

available to the Federal Government, the department or agency may terminate this transaction for cause or default.

* * * * *

2. Certification Regarding Debarment, Suspension, Ineligibility and Voluntary Exclusion – First Tier Participants:

a. The prospective first tier participant certifies to the best of its knowledge and belief, that it and its principals:

(1) Are not presently debarred, suspended, proposed for debarment, declared ineligible, or voluntarily excluded from participating in covered transactions by any Federal department or agency;

(2) Have not within a three-year period preceding this proposal been convicted of or had a civil judgment rendered against them for commission of fraud or a criminal offense in connection with obtaining, attempting to obtain, or performing a public (Federal, State or local) transaction or contract under a public transaction; violation of Federal or State antitrust statutes or commission of embezzlement, theft, forgery, bribery, falsification or destruction of records, making false statements, or receiving stolen property;

(3) Are not presently indicted for or otherwise criminally or civilly charged by a governmental entity (Federal, State or local) with commission of any of the offenses enumerated in paragraph (a)(2) of this certification; and

(4) Have not within a three-year period preceding this application/proposal had one or more public transactions (Federal, State or local) terminated for cause or default.

b. Where the prospective participant is unable to certify to any of the statements in this certification, such prospective participant shall attach an explanation to this proposal.

2. Instructions for Certification - Lower Tier Participants:

(Applicable to all subcontracts, purchase orders and other lower tier transactions requiring prior FHWA approval or estimated to cost \$25,000 or more - 2 CFR Parts 180 and 1200)

a. By signing and submitting this proposal, the prospective lower tier is providing the certification set out below.

b. The certification in this clause is a material representation of fact upon which reliance was placed when this transaction was entered into. If it is later determined that the prospective lower tier participant knowingly rendered an erroneous certification, in addition to other remedies available to the Federal Government, the department, or agency with which this transaction originated may pursue available remedies, including suspension and/or debarment.

c. The prospective lower tier participant shall provide immediate written notice to the person to which this proposal is submitted if at any time the prospective lower tier participant learns that its

certification was erroneous by reason of changed circumstances.

d. The terms "covered transaction," "debarred," "suspended," "ineligible," "participant," "person," "principal," and "voluntarily excluded," as used in this clause, are defined in 2 CFR Parts 180 and 1200. You may contact the person to which this proposal is submitted for assistance in obtaining a copy of those regulations. "First Tier Covered Transactions" refers to any covered transaction between a grantee or subgrantee of Federal funds and a participant (such as the prime or general contract). "Lower Tier Covered Transactions" refers to any covered transaction under a First Tier Covered Transaction (such as subcontracts). "First Tier Participant" refers to the participant who has entered into a covered transaction with a grantee or subgrantee of Federal funds (such as the prime or general contractor). "Lower Tier Participant" refers any participant who has entered into a covered transaction with a First Tier Participant or other Lower Tier Participants (such as subcontractors and suppliers).

e. The prospective lower tier participant agrees by submitting this proposal that, should the proposed covered transaction be entered into, it shall not knowingly enter into any lower tier covered transaction with a person who is debarred, suspended, declared ineligible, or voluntarily excluded from participation in this covered transaction, unless authorized by the department or agency with which this transaction originated.

f. The prospective lower tier participant further agrees by submitting this proposal that it will include this clause titled "Certification Regarding Debarment, Suspension, Ineligibility and Voluntary Exclusion-Lower Tier Covered Transaction," without modification, in all lower tier covered transactions and in all solicitations for lower tier covered transactions exceeding the \$25,000 threshold.

g. A participant in a covered transaction may rely upon a certification of a prospective participant in a lower tier covered transaction that is not debarred, suspended, ineligible, or voluntarily excluded from the covered transaction, unless it knows that the certification is erroneous. A participant is responsible for ensuring that its principals are not suspended, debarred, or otherwise ineligible to participate in covered transactions. To verify the eligibility of its principals, as well as the eligibility of any lower tier prospective participants, each participant may, but is not required to, check the Excluded Parties List System website (<https://www.epls.gov/>), which is compiled by the General Services Administration.

h. Nothing contained in the foregoing shall be construed to require establishment of a system of records in order to render in good faith the certification required by this clause. The knowledge and information of participant is not required to exceed that which is normally possessed by a prudent person in the ordinary course of business dealings.

i. Except for transactions authorized under paragraph e of these instructions, if a participant in a covered transaction knowingly enters into a lower tier covered transaction with a person who is suspended, debarred, ineligible, or voluntarily excluded from participation in this transaction, in addition to other remedies available to the Federal Government, the department or agency with which this transaction originated may pursue available remedies, including suspension and/or debarment.

Certification Regarding Debarment, Suspension, Ineligibility and Voluntary Exclusion--Lower Tier Participants:

1. The prospective lower tier participant certifies, by submission of this proposal, that neither it nor its principals is presently debarred, suspended, proposed for debarment, declared ineligible, or voluntarily excluded from participating in covered transactions by any Federal department or agency.

2. Where the prospective lower tier participant is unable to certify to any of the statements in this certification, such prospective participant shall attach an explanation to this proposal.

XI. CERTIFICATION REGARDING USE OF CONTRACT FUNDS FOR LOBBYING

This provision is applicable to all Federal-aid construction contracts and to all related subcontracts which exceed \$100,000 (49 CFR 20).

1. The prospective participant certifies, by signing and submitting this bid or proposal, to the best of his or her knowledge and belief, that:

a. No Federal appropriated funds have been paid or will be paid, by or on behalf of the undersigned, to any person for influencing or attempting to influence an officer or employee of any Federal agency, a Member of Congress, an officer or employee of Congress, or an employee of a Member of Congress in connection with the awarding of any Federal contract, the making of any Federal grant, the making of any Federal loan, the entering into of any cooperative agreement, and the extension, continuation, renewal, amendment, or modification of any Federal contract, grant, loan, or cooperative agreement.

b. If any funds other than Federal appropriated funds have been paid or will be paid to any person for influencing or attempting to influence an officer or employee of any Federal agency, a Member of Congress, an officer or employee of Congress, or an employee of a Member of Congress in connection with this Federal contract, grant, loan, or cooperative agreement, the undersigned shall complete and submit Standard Form-LLL, "Disclosure Form to Report Lobbying," in accordance with its instructions.

2. This certification is a material representation of fact upon which reliance was placed when this transaction was made or entered into. Submission of this certification is a prerequisite for making or entering into this transaction imposed by 31 U.S.C. 1352. Any person who fails to file the required certification shall be subject to a civil penalty of not less than \$10,000 and not more than \$100,000 for each such failure.

3. The prospective participant also agrees by submitting its bid or proposal that the participant shall require that the language of this certification be included in all lower tier subcontracts, which exceed \$100,000 and that all such recipients shall certify and disclose accordingly.

ATTACHMENT A - EMPLOYMENT AND MATERIALS PREFERENCE FOR APPALACHIAN DEVELOPMENT HIGHWAY SYSTEM OR APPALACHIAN LOCAL ACCESS ROAD CONTRACTS

This provision is applicable to all Federal-aid projects funded under the Appalachian Regional Development Act of 1965.

1. During the performance of this contract, the contractor undertaking to do work which is, or reasonably may be, done as on-site work, shall give preference to qualified persons who regularly reside in the labor area as designated by the DOL wherein the contract work is situated, or the subregion, or the Appalachian counties of the State wherein the contract work is situated, except:

a. To the extent that qualified persons regularly residing in the area are not available.

b. For the reasonable needs of the contractor to employ supervisory or specially experienced personnel necessary to assure an efficient execution of the contract work.

c. For the obligation of the contractor to offer employment to present or former employees as the result of a lawful collective bargaining contract, provided that the number of nonresident persons employed under this subparagraph (1c) shall not exceed 20 percent of the total number of employees employed by the contractor on the contract work, except as provided in subparagraph (4) below.

2. The contractor shall place a job order with the State Employment Service indicating (a) the classifications of the laborers, mechanics and other employees required to perform the contract work, (b) the number of employees required in each classification, (c) the date on which the participant estimates such employees will be required, and (d) any other pertinent information required by the State Employment Service to complete the job order form. The job order may be placed with the State Employment Service in writing or by telephone. If during the course of the contract work, the information submitted by the contractor in the original job order is substantially modified, the participant shall promptly notify the State Employment Service.

3. The contractor shall give full consideration to all qualified job applicants referred to him by the State Employment Service. The contractor is not required to grant employment to any job applicants who, in his opinion, are not qualified to perform the classification of work required.

4. If, within one week following the placing of a job order by the contractor with the State Employment Service, the State Employment Service is unable to refer any qualified job applicants to the contractor, or less than the number requested, the State Employment Service will forward a certificate to the contractor indicating the unavailability of applicants. Such certificate shall be made a part of the contractor's permanent project records. Upon receipt of this certificate, the contractor may employ persons who do not normally reside in the labor area to fill positions covered by the certificate, notwithstanding the provisions of subparagraph (1c) above.

5. The provisions of 23 CFR 633.207(e) allow the contracting agency to provide a contractual preference for the use of mineral resource materials native to the Appalachian region.

STANDARD FEDERAL EQUAL EMPLOYMENT OPPORTUNITY CONSTRUCTION CONTRACT SPECIFICATIONS

NOTICE OF REQUIREMENT FOR AFFIRMATIVE ACTION TO ENSURE EQUAL EMPLOYMENT OPPORTUNITY (EXECUTIVE ORDER 11246)

1. The Offeror's or Bidders attention is called to the "Equal Opportunity Clause" and the "Standard Federal Equal Employment Opportunity Construction Contract Specifications" set forth herein.
2. The goals and timetables for minority and female participation expressed in percentage terms for the Contractor's aggregate work force in each trade on all construction work in the covered area are as follows:

Goals for Women Apply Nationwide

GOALS AND TIMETABLES

<i>Timetable</i>	<i>Goals (percent)</i>
From Apr. 1, 1976 until March 31, 1979-----	3.1
--	
From Apr. 1, 1979 until March 31, 1980-----	5.1
--	
From Apr. 1, 1980 until March 31, 1981-----	6.9
--	

Goals for Minority Participation

South Carolina	
SMSA Counties:.....	16.0
Greenville, Pickens, Spartanburg	
Non-SMSA Counties:.....	17.8
Abbeville, Anderson, Cherokee, Greenwood, Laurens, Oconee, Union	
SMSA Counties:.....	23.4
Lexington, Richland	
Non-SMSA Counties.....	32.0
Calhoun, Clarendon, Fairfield, Kershaw, Lee, Newberry, Orangeburg, Saluda, Sumter	
Non-SMSA Counties.....	33.0
Chesterfield, Darlington, Dillon, Florence, Georgetown, Horry, Marion, Marlboro, Williamsburg	
SMSA Counties:.....	30.0
Berkeley, Charleston, Dorchester	
Non-SMSA Counties.....	30.7
Colleton	
Non-SMSA Counties.....	29.8
Beaufort, Hampton, Jasper	
Non-SMSA Counties.....	15.7
Chester Lancaster York	
Non-SMSA Counties.....	32.8
Barnwell, Edgefield, McCormick, Allendale, Bamberg	
SMSA Counties:.....	27.2
Aiken	

These goals are applicable to all the Contractor's construction work (whether or not it is Federal or federally assisted) performed in the covered area. If the Contractor performs construction work in a geographical area located outside of the covered area, it shall apply the goals established for such geographical areas where the work is actually performed. With regard to this second area, the Contractor is also subject to the goals for both its federally involved and nonfederally involved construction.

The Contractor's compliance with the Executive Order and the regulations in 41 CFR Part 60-4 Shall be based on its implementation of the Equal Opportunity Clause, specific affirmative action obligations required by the specifications

set forth in 41 CFR 60-4.3(a) and its efforts to meet the goals established for the geographical area where the contract resulting from this solicitation is to be performed. The hours of minority and female employment and training must be substantially uniform throughout the length of the contract, and in each trade, and the Contractor shall make a good faith effort to employ minorities and women evenly on each of its projects. The transfer of minority or female employees of trainees from Contractor to Contractor or from project to project for the sole purpose of meeting the Contractor's goals shall be a violation of the contract, the Executive Order and the regulations in 41 CFR Part 60-4. Compliance with the goals will be measured against the total work hours performed.

3. The Contractor shall provide written notification to the Director of the Office of Federal Contract Compliance Programs within 10 working days of award of any construction subcontract in excess of \$10,000 at any tier for construction work under the contract resulting from this solicitation. The notification shall list the name, address and telephone number of the subcontractor, employer identification number, estimated dollar amount of the subcontract; estimated starting and completion dates of the subcontract; and the geographical area in which the contract is to be performed.
4. As used in this Notice and in the contract resulting from this solicitation, the "covered area" is (insert description of the geographical areas where the contract is to be performed giving the state, county, and city, if any). The "covered area is the SMSA County or Counties or Non-SMSA County or Counties in which the contract work is performed.

STANDARD FEDERAL EQUAL EMPLOYMENT OPPORTUNITY CONSTRUCTION CONTRACT SPECIFICATIONS (EXECUTIVE ORDER 11246)

1. As used in these specifications:
 - a. "Covered area" means the geographical area described in the solicitation from which this contract resulted;
 - b. "Director" means Director, Office of Federal Contract Compliance Programs, United States Department of Labor, or any person to whom the Director delegates authority;
 - c. "Employer identification number" means the Federal Social Security number used on the Employers Quarterly Federal Tax Return, U. S. Treasury Department Form 941.
 - d. "Minority" includes:
 - (i) Black (all persons having origins in any of the Black African racial groups not of Hispanic origin);
 - (ii) Hispanic (all persons of Mexican, Puerto Rican, Cuban, Central or South American or other Spanish Culture or origin regardless of race);
 - (iii) Asian or Pacific Islander (all persons having origins in any of the original peoples of the Far East, Southeast Asia, the Indian Subcontinent, or the Pacific Islands); and
 - (iv) American Indian or Alaskan Native (all persons having origins in any of the original peoples of North America and maintaining identifiable tribal affiliations through membership and participation or community identification).
2. Whenever the Contractor, or any Subcontractor at any tier, subcontracts a portion of the work involving any construction trade, it shall physically include in each subcontract in excess of \$10,000 the provisions of these specifications and the Notice which contains the applicable goals for minority and female participation and which is set forth in the solicitations from which this contract resulted.

3. If the Contractor is participating (pursuant to 41 CFR 60-4.5) in a Hometown Plan approved by the U. S. Department of Labor in the covered area either individually or through an association, its affirmative action obligations on all work in the Plan area (including goals and timetables) shall be in accordance with that Plan for those trades which have unions participating in the Plan. Contractors must be able to demonstrate their participation in and compliance with the provisions of any such Hometown Plan. Each Contractor or Subcontractor participating in an approved Plan is individually required to comply with its obligations under the EEO clause, and to make a good faith effort to achieve each goal under the Plan in each trade in which it has employees. The overall good faith performance by other Contractors or Subcontractors toward a goal in an approved Plan does not excuse any covered Contractor's or Subcontractor's failure to take good faith efforts to achieve the Plan goals and timetables.
4. The Contractor shall implement the specific affirmative action standards provided in paragraphs 7a through p of these specifications. The goals set forth in the solicitation from which this contract resulted are expressed as percentages of the total hours of employment and training of minority and female utilization the Contractor should reasonably be able to achieve in which it has employees in each construction trade in which it has employees in the covered area. Covered construction contractors performing construction work in geographical areas where they do not have a Federal or federally assisted construction contract shall apply the minority and female goals established for the geographical area where the work is being performed. Goals are published periodically in the Federal Register in notices form and such notices may be obtained from any Office of Federal Contract Compliance Programs office or from Federal procurement contracting officers. The Contractor is expected to make substantially uniform progress toward its goals in each craft during the period specified.
5. Neither the provisions of any collective bargaining agreement, nor the failure by a union with whom the Contractor has a collective bargaining agreement to refer either minorities or women shall excuse the Contractor's obligations under these specifications, Executive Order 11246, or the regulations promulgated pursuant thereto.
6. In order for the non-working training hours of apprentices and trainees to be counted in meeting the goals, such apprentices and trainees must be employed by the Contractor during the training period, and the Contractor must have made a commitment to employ the apprentices and trainees at the completion of their training, subject to the availability of employment opportunities. Trainees must be trained pursuant to training programs approved by the U. S. Department of Labor.
7. The Contractor shall take specific affirmative actions to ensure equal employment opportunity. The evaluation of the Contractor's compliance with these specifications shall be based upon its effort to achieve maximum results from its actions. The Contractor shall document these efforts fully, and shall implement affirmative action steps at least as extensive as the following:
 - a. Ensure and maintain a working environment free of harassment, intimidation, and coercion at all sites, and in all facilities at which the Contractor's employees are assigned to work. The Contractor where possible, will assign two or more women to each construction project. The Contractor shall specifically ensure that all foremen, superintendents and other on-site supervisory personnel are aware of and carry out the Contractor's obligation to maintain such a working environment, with specific attention to minority of female individuals working at such sites or in such facilities.
 - b. Establish and maintain a current list of minority and female recruitment sources, provide written notification to minority recruitment sources and to community organizations when the Contractor or its unions have employment opportunities available and maintain a record of the organization's responses.
- c. Maintain a current file of the names, addresses and telephone numbers of each minority and female off-the-street applicant and minority or female referral from a union, a recruitment source or community organization and of what action was taken with respect to each individual. If such individual was sent to the union hiring hall for referral and was not referred back to the Contractor by the union or, if referred, not employed by the Contractor, this shall be documented in the file with the reason therefor, along with whatever additional actions the Contractor may taken.
- d. Provide immediate written notification to the Director when union or unions with which the Contractor has a collective bargaining agreement has not referred to the Contractor a minority person or woman sent by the Contractor, or when the Contractor has other information that the union referral process has impeded the Contractor's efforts to meet his obligations.
- e. Develop on-the-job training opportunities and/or participate in training programs for the area which expressly include minorities and women, including upgrading programs and apprenticeship and trainee programs relevant to the Contractor's employment needs, especially those programs funded by the Department of Labor. The Contractor shall provide notice of these programs to the sources compiled under 7b above.
- f. Disseminate the Contractor's EEO policy to unions and training programs and requesting their cooperation in assisting the Contractor in meeting its EEO obligations; by including it in any policy manual and collective bargaining agreement; by publicizing it in the company newspaper, annual report, etc.; by specific review of the policy with all management personnel and with all minority and female employees at least once a year; and by posting the company EEO policy on bulletin boards accessible to all employees at each location where construction work is performed.
- g. Review at least annually, the company's EEO policy and affirmative action obligations under these specifications with all employees having any responsibility for hiring, assignment, layoff, termination or other employment decisions including specific review of these items with on-site supervisory personnel such as Superintendents, General Foremen, etc., prior to the initialization of construction work at any job site. A written record shall be made and maintained identifying the time and place of these meetings, persons attending, subject matter discussed, and disposition of the subject matter.
- h. Disseminate the Contractor's EEO policy externally by including it in any advertising in the news media, specifically including minority and female news media, and providing written notification to and discussing the Contractor's EEO policy with other Contractors and Subcontractors with whom the Contractor does or anticipates doing business.
- i. Direct its recruitment efforts, both oral and written, to minority, female and community organizations, to schools with minority and female students and to minority and female recruitment and training organizations serving the Contractor's recruitment area and employment needs. Not later than one month prior to the date for the acceptance of applications for apprenticeship or other training by any recruitment source, the Contractor shall sent written notification to organizations such as the above, describing the openings, screening procedures and tests to be used in the selection process.
- j. Encourage present minority and female employees to recruit other minority persons and women and where reasonable, provide after school, summer, and vacation employment to minority and female youth both on the site and in other areas of a Contractor's work force.

- k. Validate all tests and other selection requirements where there is an obligation to do so under 41 CFR Part 60-3.
 - l. Conduct, at least annually, an inventory and evaluation at least of all minority and female personnel for promotional opportunities and encourage these employees to seek or to prepare for, through appropriate training, etc., such opportunities.
 - m. Ensure that all seniority practices, job classifications, work assignments and other personnel practices, do not have a discriminatory effect by continually monitoring all personnel and employment related activities to ensure that the EEO policy and the Contractor's obligations under these specifications are being carried out.
 - n. Ensure that all facilities and company activities are non-segregated except that separate or single-user toilet and necessary changing facilities shall be provided to assure privacy between the sexes.
 - o. Document and maintain a record of all solicitations of offers for subcontracts from minority and female construction contractors and suppliers, including circulation of solicitations to minority and female contractor associations and other business associations.
 - p. Conduct a review, at least annually of all supervisors' adherence to and performance under the Contractor's EEO policies and affirmative action obligations.
8. Contractors are encouraged to participate in voluntary associations which assist in fulfilling one or more of their affirmative action obligations (7a through p). The efforts of a contractor association joint contractor-union, contractor-community, or other similar group of which the Contractor is a member and participant, may be asserted as fulfilling any one or more of its obligations under 7a through p of these specifications provided that the contractor actively participates in the group, makes every effort to assure that the group has a positive impact on the employment of minorities and women in the industry, ensures that the concrete benefits of the program are reflected in the contractor's minority and female work force participation, makes a good faith effort to meet its individual goals and timetables, and can provide access to documentation which demonstrates the effectiveness of actions taken on behalf of the Contractor. The obligation to comply, however, is the Contractor's and failure of such a group to fulfill an obligation shall not be a defense for the Contractor's noncompliance.
9. A single goal for minorities and a separate single goal for women have been established. The Contractor, however, is required to provide equal employment opportunity and take affirmative action for all minority groups, both male and female, and all women, both minority and non-minority. Consequently, the Contractor may be in violation of the Executive Order if a particular group is employed in a substantially disparate manner (for example, even though the Contractor may be in violation of the Executive Order if a specific minority group of women is underutilized).
10. The Contractor shall not use the goals and timetables or affirmative action standards to discriminate against any person because of race, color, religion, sex, or national origin.
11. The Contractor shall not enter into any Subcontract with any person or firm debarred from the Government contracts pursuant to the executive Order 11246.
12. The Contractor shall carry out such sanctions and penalties for violation of these specifications and the Equal Opportunity Clause, including suspensions, termination and cancellation of the existing subcontracts as may be imposed or ordered pursuant to Executive Order 11246, as amended. and its implementing regulations, by the Office if the Federal Compliance Programs. Any Contractor who fails to carry out such sanctions and penalties shall be in violation of the specifications and Executive Order 11246, as amended.
13. The Contractor, in fulfilling its obligations under these specifications, shall implement specific affirmative action steps, at least as extensive as those standards prescribed in paragraph 7 of these specifications, so as to achieve maximum results from its efforts to ensure equal employment opportunity. If the Contractor fails to comply with the requirements of the executive Order, the implementing regulations, or these specifications, the Director shall proceed in accordance with 41 CFR 60-4-8.
14. The Contractor shall designate a responsible official to monitor all employment related activity to ensure that the company EEO policy is being carried out, to submit reports relating to the provisions hereof as may be required by the Government and to keep records. Records shall at least include for each employee the name, address, telephone numbers, construction trade, union affiliation if any employee identification number when assigned, social security number, race, sex status(e.g., Mechanic, apprentice, trainee, helper, or laborer), dates of changes in status, hours worked per week in the indicated trade, rate of pay, and location at which the work was performed. Records shall be maintained in an easily understandable and retrievable form; however, to the degree that the existing records satisfy this requirement, contractors shall not be required to maintain separate records.
15. Nothing herein provided shall be construed as a limitation upon the application of other laws which establish different standards of compliance or upon the application of requirements for the hiring of local or other area residents(e.g. those under the Public Works Employment Act of 1977 and the Community Development Block Grant Program).

Superseded General Decision Number: SC20100068

State: South Carolina

Construction Type: Highway

Counties: Berkeley, Charleston, Dorchester and Horry Counties in South Carolina.

HIGHWAY CONSTRUCTION PROJECTS (excluding tunnels, building structures in rest area projects & railroad construction; bascule, suspension & spandrel arch bridges designed for commercial navigation, bridges involving marine construction; and other major bridges).

Modification Number	Publication Date
0	01/04/2013

SUSC2011-032 09/15/2011

	Rates	Fringes
--	-------	---------

CARPENTER (Form Work Only)

Berkeley, Dorchester.....	\$ 13.50	
Charleston.....	\$ 13.07	
Horry.....	\$ 14.29	

CEMENT MASON/CONCRETE FINISHER

Berkeley, Dorchester.....	\$ 14.79	
Charleston.....	\$ 14.33	
Horry.....	\$ 14.62	

IRONWORKER, REINFORCING.....\$ 15.35

LABORER

Asphalt, Includes Asphalt Distributor, Raker, Shoveler, and Spreader Berkeley, Charleston, Dorchester.....	\$ 11.62	
--	----------	--

Asphalt, Includes Asphalt Distributor, Shoveler and Spreader Horry.....	\$ 11.54	
---	----------	--

Common or General Berkeley.....	\$ 10.06	
Charleston.....	\$ 10.16	
Dorchester.....	\$ 11.69	
Horry.....	\$ 9.72	
Luteman.....	\$ 11.61	

Mason Tender-Cement/Concrete.....	\$ 10.40	
Pipelayer.....	\$ 13.98	
Traffic Control-Cone Setter Berkeley, Charleston,		

Dorechester.....	\$ 13.19	
Horry.....	\$ 12.63	
Traffic Control-Flagger.....	\$ 11.07	

POWER EQUIPMENT OPERATOR:

Backhoe/Excavator/Trackhoe		
Berkeley.....	\$ 15.68	
Charleston.....	\$ 16.09	
Dorchester.....	\$ 16.06	
Horry.....	\$ 15.04	
Bulldozer.....	\$ 14.81	
Crane		
Berkeley, Dorchester.....	\$ 20.00	4.73
Charleston.....	\$ 20.08	
Horry.....	\$ 20.58	
Grader/Blade.....	\$ 14.61	
Hydroseeder.....	\$ 11.00	
Loader (Front End/Track)....	\$ 16.80	
Mechanic		
Berkeley, Dorchester.....	\$ 19.07	
Charleston.....	\$ 19.21	
Horry.....	\$ 19.48	
Milling Machine.....	\$ 11.84	
Paver		
Berkeley, Charleston,		
Dorchester.....	\$ 18.85	
Horry.....	\$ 13.29	
Roller.....	\$ 15.17	
Scraper.....	\$ 12.71	
Screed.....	\$ 13.56	
Tractor.....	\$ 13.28	

TRUCK DRIVER

Dump Truck.....	\$ 10.67
Lowboy Truck.....	\$ 15.55

WELDERS - Receive rate prescribed for craft performing operation to which welding is incidental.

=====

Unlisted classifications needed for work not included within the scope of the classifications listed may be added after award only as provided in the labor standards contract clauses (29CFR 5.5 (a) (1) (ii)).

The body of each wage determination lists the classification and wage rates that have been found to be prevailing for the cited type(s) of construction in the area covered by the wage determination. The classifications are listed in alphabetical order of "identifiers" that indicate whether the particular rate is union or non-union.

Union Identifiers

An identifier enclosed in dotted lines beginning with characters other than "SU" denotes that the union classification and rate have found to be prevailing for that classification. Example: PLUM0198-005 07/01/2011. The

first four letters , PLUM, indicate the international union and the four-digit number, 0198, that follows indicates the local union number or district council number where applicable , i.e., Plumbers Local 0198. The next number, 005 in the example, is an internal number used in processing the wage determination. The date, 07/01/2011, following these characters is the effective date of the most current negotiated rate/collective bargaining agreement which would be July 1, 2011 in the above example.

Union prevailing wage rates will be updated to reflect any changes in the collective bargaining agreements governing the rate.

Non-Union Identifiers

Classifications listed under an "SU" identifier were derived from survey data by computing average rates and are not union rates; however, the data used in computing these rates may include both union and non-union data. Example: SULA2004-007 5/13/2010. SU indicates the rates are not union rates, LA indicates the State of Louisiana; 2004 is the year of the survey; and 007 is an internal number used in producing the wage determination. A 1993 or later date, 5/13/2010, indicates the classifications and rates under that identifier were issued as a General Wage Determination on that date.

Survey wage rates will remain in effect and will not change until a new survey is conducted.

WAGE DETERMINATION APPEALS PROCESS

1.) Has there been an initial decision in the matter? This can be:

- * an existing published wage determination
- * a survey underlying a wage determination
- * a Wage and Hour Division letter setting forth a position on a wage determination matter
- * a conformance (additional classification and rate) ruling

On survey related matters, initial contact, including requests for summaries of surveys, should be with the Wage and Hour Regional Office for the area in which the survey was conducted because those Regional Offices have responsibility for the Davis-Bacon survey program. If the response from this initial contact is not satisfactory, then the process described in 2.) and 3.) should be followed.

With regard to any other matter not yet ripe for the formal process described here, initial contact should be with the Branch of Construction Wage Determinations. Write to:

Branch of Construction Wage Determinations
Wage and Hour Division
U.S. Department of Labor
200 Constitution Avenue, N.W.
Washington, DC 20210

2.) If the answer to the question in 1.) is yes, then an interested party (those affected by the action) can request review and reconsideration from the Wage and Hour Administrator (See 29 CFR Part 1.8 and 29 CFR Part 7). Write to:

Wage and Hour Administrator
U.S. Department of Labor
200 Constitution Avenue, N.W.
Washington, DC 20210

The request should be accompanied by a full statement of the interested party's position and by any information (wage payment data, project description, area practice material, etc.) that the requestor considers relevant to the issue.

3.) If the decision of the Administrator is not favorable, an interested party may appeal directly to the Administrative Review Board (formerly the Wage Appeals Board). Write to:

Administrative Review Board
U.S. Department of Labor
200 Constitution Avenue, N.W.
Washington, DC 20210

4.) All decisions by the Administrative Review Board are final.

=====

END OF GENERAL DECISION

DISADVANTAGED BUSINESS ENTERPRISES (DBE)
COMMITTAL SHEET

Information must be shown on this sheet as required by the supplemental specifications entitled "Instructions to Bidders - Federal Projects" and "Disadvantaged Business Enterprises (DBE) - Federal Projects" included in this proposal.

FAILURE TO PROVIDE ALL INFORMATION REQUIRED ON THIS FORM MAY RESULT IN THE AWARD BEING MADE TO THE NEXT LOWEST RESPONSIBLE BIDDER.

¹ Name & Address of DBE's (Subcontractor or Supplier)	² Percent	³ Description of Work and Approximate Quantity ⁶ (show percent when appropriate)				⁵ Dollar Value
		Item	Qty.	Unit	⁴ Unit Price	

- ¹ The designation of Firm A and/or B is not considered acceptable. I hereby certify that this company has communicated with and received quotes from the DBE's listed above and that they are willing to perform the work as listed above and that this company is committed to utilizing the above firm(s) on this contract.
- ² Percent - show percent of total contract amount committed to each DBE listed.
- ³ All information requested must be included unless item is listed in proposal on a lump sum basis.
- ⁴ Unit Price - show unit price quoted by DBE.
- ⁵ Dollar Value - extended amount based on Quantity and Unit Price.
- ⁶ Applies to lump sum items only.

This form may be reproduced or additional sheets added in order to provide all requested information. (See *Instructions to Bidders - Federal Projects*).

SWORN to before me this _____ day of _____, 20____ Company _____

(Seal) By: _____
Notary Public for _____
My commission expires: _____ Title: _____

EXHIBIT 8

ENVIRONMENTAL INFORMATION

EXHIBIT 8 – ENVIRONMENTAL INFORMATION

Project Environmental Commitments

The following special commitments have been agreed to by the SCDOT:

Commitment	EA Reference Page
South Carolina Department of Transportation (SCDOT) will provide the project’s environmental document to local planning officials to assist Charleston and Berkeley Counties and the Town of Mount Pleasant to regulate land use consistency adjacent to the proposed project.	Section 4.1 Land use; page 15
Coordination with the Charleston District of the U.S. Army Corps of Engineers (USACE) and South Carolina Department of Health and Environmental Control – Office of Ocean and Coastal Resource Management (OCRM) regarding the potential impacts of this project on the Wando River and surrounding water bodies will occur through the Section 401/404 permitting process. In addition, the contractor would be required to minimize potential impacts through implementation of construction best management practices, reflecting policies contained in 23 CFR 650 B and SCDOT’s Supplemental Specifications on Seeding and Erosion Control Measures.	Section 4.5 Permits, page 26
SCDOT will submit a stormwater drainage plan to SCDHEC prior to finalizing construction plans.	Section 4.3 Water Quality, page 16
Stormwater control measures, both during construction and post-construction, are required for SCDOT projects constructed in the vicinity of 303(d), TMDL, ORW, tidal, and shellfish beds in accordance with the SCDOT’s MS4 Permit.	Not included in EA
SCDOT will comply with Executive Order 11990 regarding the protection of wetlands. The implementation of appropriate sediment and erosion control measures will be required of the contractor to ensure compliance with policies reflected in 23 CFR 650B. Reclamation of wetland areas disturbed during construction activities will involve returning the areas to their original elevations to allow for natural reforestation.	Section 4.4 Wetlands and Waters of the US, Page 24

EXHIBIT 8 – ENVIRONMENTAL INFORMATION

Commitment	EA Reference Page
<p>Permit coordination will be carried out with the USACE and the U.S. Coast Guard for the design and construction of the Wando River Bridge and roadway improvements and specific mitigation requirements will be established during the permitting process. A USACE Individual Permit is anticipated for the project.</p>	<p>Section 4.5 Permits, page 26</p>
<p>SCDOT will not require restrictive covenants to be placed on wetlands within existing or new right of way. The statement in the EA was made in error. The contractor will not be responsible for preparing legal documents for restrictive covenants.</p>	<p>Section 4.6 Mitigation, page 26</p>
<p>Floodplains will be crossed in such a way as to not increase the height of the base flood elevation by more than 0.1 foot during the 100-year storm.</p>	<p>Section 4.7 Floodplains, page 27</p>
<p>A copy of the finalized hydraulic report will be delivered to the floodplain administrators within Charleston and Berkeley Counties for review and comment/concurrence. This coordination will take place during the USACE permitting process.</p>	<p>Section 4.7 Floodplains, page 29</p>
<p>SCDOT will inform local planning officials of future, generalized noise levels expected to occur in the project vicinity.</p>	<p>Section 4.12 Noise, page 37 THIS HAS BEEN COMPLETED BY SCDOT AND REQUIRES NO FURTHER WORK BY THE CONTRACTOR.</p>
<p>Asbestos containing materials may be present in buildings in the project corridor, therefore surveys of any buildings to be demolished will be conducted as required by SCDHEC and materials should be handled in accordance with state and federal regulations.</p>	<p>Section 4.13 Hazardous Waste and underground Storage Tanks (HAZMAT), Page 40</p>
<p>If avoidance of Underground Storage Tanks (USTs) is not a viable alternative, tanks and other hazardous materials will be tested and removed and/or treated in accordance with the U.S. Environmental Protection Agency (EPA) and South Carolina Department of Health and Environmental Control (SCDHEC) requirements. Costs necessary for clean up would be taken into consideration during the right of way appraisal and acquisition process.</p>	<p>Section 4.13 Hazardous Waste and underground Storage Tanks (HAZMAT), Page 41</p>

EXHIBIT 8 – ENVIRONMENTAL INFORMATION

Commitment	EA Reference Page
<p>A Memorandum of Agreement (MOA) to mitigate the adverse impact to the bridge has been executed between the SCDOT and SHPO and is included in the appendix.</p>	<p>Section 4.14 Cultural Resources, page 44 THIS HAS BEEN COMPLETED BY SCDOT AND REQUIRES NO FURTHER WORK BY THE CONTRACTOR.</p>
<p>If unanticipated cultural materials or human skeletal remains are discovered during construction activities, the SCDOT County Resident Construction Engineer shall be immediately notified and all work in the vicinity of the discovered materials shall cease until an evaluation can be made by an SCDOT archaeologist in consultation with the SHPO.</p>	<p>Section 4.14 Cultural Resources, page 44</p>
<p>Property owners will be fairly compensated for the right of way acquired for the project and for any damages to remaining property, in accordance with SCDOT policy and the Uniform Relocation Assistance and Real Property Acquisition Policies Act of 1970, as amended</p>	<p>Section 4.16 Relocations, page 45</p>
<p>The department will provide the final EFH assessment to NMFS during the Section 404 permitting process.</p>	<p>Not included in EA. The contractor will be responsible for preparing the EFH assessment and quantifying the final impacts on Essential Fish Habitat. On behalf of FHWA, SCDOT will be responsible for the submittal of the EFH assessment to NMFS for review and any further agency coordination. The contractor will be responsible for all revisions to the EFH assessment required by NMFS and any conservation recommendations by NMFS.</p>
<p>Upon construction completion of the new bridge and the shifting of traffic onto the new bridge the existing bridge will be removed in its entirety. The piers and swing span substructures of the existing bridge will be removed to the natural bottom in accordance with SCDOT stand specifications (Section 202.4.2.4).</p>	<p>FONSI Commitment</p>
<p>To reduce potential impacts to the Atlantic Sturgeon during construction, SCDOT will restrict “in-water” work between January 1 and April 15. For this project, “in-water” has been defined as any activity that that could result in the physical destruction or alteration (e.g. excavation, fill, pile driving, drilled shaft construction) of</p>	<p>FONSI Commitment</p>

EXHIBIT 8 – ENVIRONMENTAL INFORMATION

Commitment	EA Reference Page
<p>important spawning habitats. During the moratorium, the contractor would be allowed to work from a barge in order to construct columns, caps, and bridge superstructure. The contractor would be allowed to move barges between shafts during the moratorium; however, barges must be secured by cables as placement of spuds to secure barges will not be allowed during the moratorium. Equipment and materials used during the construction of the bridge will not obstruct or impede passage through more than 50 percent of the channel.</p>	

CONTRACTOR should be aware that all permitting should be coordinated through SCDOT's Environmental Management Office.

EXHIBIT 9

ESCROW PROPOSAL DOCUMENTS

Procedure to Escrow Bid Documentation by Delivery Service

The following is the procedure by which a Contractor may elect to use a delivery service to escrow bid documentation as required by the contract special provision in SCDOT contracts entitled: Escrow Bid Documentation, dated July 17, 1995. To successfully carry out this procedure, it is extremely important that each step be followed precisely. To preserve the chain of custody of the sealed bid documents, a delivery service with a tracking system such as Fed Ex, UPS, or DHL must be used. The person who signs the escrow agreement must be a person that has the authority to sign an agreement on behalf of the Contractor.

1. To initiate the process, SCDOT Contract Administration office will:
 - a. Prepare and send to the Contractor, three (3) copies of the Escrow Agreement for Contract Bid Documents and one (1) copy of the Affidavit.
 - b. Inform the Contractor and the U.S. Bank Corporate Trust Group that the escrow process has been initiated.
2. Upon receipt of the three (3) copies of the Escrow Agreement and copy of the Affidavit, the Contractor shall:
 - a. Fill in the date the bid document container is sealed on the page 1 and page 4 of each of the three (3) copies of the Escrow Agreement.
 - b. At the bottom of page 3 of the Escrow Agreement, print the signers name, sign, and witness all three (3) copies of the Agreement.
 - c. Complete, sign, and notarize the Affidavit.
 - d. Make two copies of the notarized Affidavit, one for the Contractor and one to send with the three (3) Agreements.
 - e. After making any copies of the contract bid documents and the Affidavit, place the contract bid documents and the original of the Affidavit in a suitable document container, such as a tear-resistant Tyvek envelope.
 - f. **DO NOT** put a three-ring binder or any other metal binding devises in the bid document container.
 - g. On the front of the bid document container, print the following information:
 - Contractor's Name
 - SC File No(s).
 - Date that the bid document container was sealed
 - h. Seal the contract bid document container by wrapping clear tape in a continuous line at least once lengthwise and once widthwise around the container. Sign your name across each line of tape, so that part of the signature is partially on the tape and partially on the container. Use a ballpoint pen to sign because ink from other types of pens can generally be wiped off of the tape.

- i. Place the sealed contract bid document container, the three (3) signed Agreements, and a copy of the Affidavit into a second outer container labeled with the following instructions prominently visible:

ESCROW DOCUMENTS
TO BE OPENED ONLY BY
NATALIE McNAIR
CORPORATE TRUST GROUP
 - j. Place the second outer container into a delivery service shipping container.
 - k. Send the shipping container via delivery service, such as Fed Ex, UPS, or DHL, addressed as follows:

Natalie McNair - Escrow Documents
U.S. Bank - Corporate Trust Group
1441 Main Street, Suite 775
Columbia, SC 29201
Phone 803-212-7905
 - l. Immediately after the package is given to the delivery service, call the SCDOT Contracts Administration Office (803) 737-1434 and provide the tracking number.
3. After accepting delivery of the package containing the three (3) copies of the Escrow Agreement, original copy of the Affidavit, and sealed bid document container, Natalie McNair of the U.S. Bank will:
 - a. Take possession of the sealed bid document container and sign across the sealing tape.
 - b. Sign and witness the three (3) copies of the Escrow Agreement.
 - c. Send the three (3) copies of the Agreement and the copy of the Affidavit to the SCDOT Contracts Administration office in the headquarters building in Columbia.
 4. Upon receipt of the three (3) copies of the escrow agreement and the copy of the Affidavit, the SCDOT Contract Administration office will:
 - a. Sign and witness the three (3) Escrow Agreements.
 - b. Send a fully executed copy Escrow Agreement to the Contractor.
 - c. Send fully executed copy Escrow Agreement to U.S. Bank

If you have any questions about the steps in this procedure, please call the SCDOT Contracts Administration office at (803) 737-1434. It is extremely **IMPORTANT** to follow the steps prescribed above.

G. A. Peck
Contracts Engineer
803-737-1434

**SAMPLE ESCROW AGREEMENT
SCDOT CONTRACT ADMINISTRATION WILL PROVIDE AGREEMENT FOR SIGNATURES**

**ESCROW AGREEMENT
FOR
CONTRACT BID DOCUMENTS**

THIS AGREEMENT is made and entered into this **Day** day of **Month, Year**, by and among the South Carolina Department of Transportation, an agency of the State of South Carolina, hereinafter called the "DEPARTMENT", and **Contractor's Name**, hereinafter called the "CONTRACTOR", and **Bank's Name**, hereinafter called the "ESCROW AGENT".

WHEREAS, the DEPARTMENT and the CONTRACTOR desire to enter into a Construction Contract for work in SC File No(s). **Project File No(s)**, hereinafter called the "CONTRACT", pursuant to which the CONTRACTOR shall cause the work therein to be constructed; and

WHEREAS, the DEPARTMENT and CONTRACTOR desire to enter into an Escrow Agreement, to provide for specific contingencies governing the escrow and control of Contract bid documentation; hereinafter called "BID DOCUMENTS"; and

WHEREAS, the DEPARTMENT and CONTRACTOR desire the ESCROW AGENT to hold the BID DOCUMENTS of the CONTRACTOR;

NOW, THEREFORE, for and in consideration of the mutual covenants contained herein, it is agreed by and between the parties hereto that:

ARTICLE I
ESCROW OF THE CONTRACT BID DOCUMENTATION

The parties hereto agree to the establishment of Escrow of the BID DOCUMENTS for the CONTRACT pursuant to the DEPARTMENT'S Standard Specifications for Highway Construction (Edition of 2007), and Supplemental Specifications or Special Provisions pertaining to construction under the CONTRACT. It is the understanding of the parties hereto that the DEPARTMENT shall pay the ESCROW AGENT, as determined by separate Agreement, for the escrow of the BID DOCUMENTS submitted to the ESCROW AGENT under the terms of this Agreement.

ARTICLE II
ACKNOWLEDGEMENT

By its signature below, the ESCROW AGENT hereby acknowledges receipt from the DEPARTMENT and CONTRACTOR of a sealed container bearing the CONTRACTOR's name, address, and CONTRACT File Number(s) assigned by the DEPARTMENT and containing the CONTRACT BID DOCUMENTS.

ARTICLE III
DEPOSIT OF BID DOCUMENTS

The CONTRACT BID DOCUMENTS shall remain on deposit with the ESCROW AGENT until those conditions of release, as specified in ARTICLE IV "RELEASE FROM ESCROW", are met. As long as the BID DOCUMENTS remain in escrow with the ESCROW AGENT, the ESCROW AGENT shall not allow any person access, to gain possession, or in any way to interfere with the sealed BID DOCUMENT container.

ARTICLE IV
RELEASE FROM ESCROW

Upon being presented with documentation from the DEPARTMENT, signed by the Contract Administrator, that the Final Estimate for the CONTRACT has been paid to the CONTRACTOR, the ESCROW AGENT shall deliver to the CONTRACTOR the sealed container bearing the CONTRACTOR's name and address and File Number(s) on it. The ESCROW AGENT is also authorized to release the CONTRACT BID DOCUMENT sealed container to the DEPARTMENT without the CONTRACTOR's signed consent subject to written documentation, signed by the DEPARTMENT's Contract Administrator, that one or both of the following conditions have occurred:

1. The CONTRACTOR has filed a claim against the DEPARTMENT related to the project.
2. The CONTRACTOR has initiated litigation against the DEPARTMENT relating to the CONTRACT.

Prior to any release from escrow to the DEPARTMENT, the ESCROW AGENT shall provide written notice to the CONTRACTOR of the ESCROW AGENT's intention to release the CONTRACT BID DOCUMENTS sealed container to the DEPARTMENT. Such written notice from the ESCROW AGENT shall be sent by certified mail no less than ten (10) calendar days prior to release of the CONTRACT BID DOCUMENTS sealed container to the DEPARTMENT. Upon any release from escrow of the CONTRACT BID DOCUMENT sealed container, the party receiving the sealed container shall sign Exhibit A, ESCROW RELEASE FOR CONTRACT BID DOCUMENTS, as attached hereto and incorporated herein as if fully contained, by the party receiving the BID DOCUMENT container.

ARTICLE V
INDEMNITY

The CONTRACTOR agrees to indemnify and hold the ESCROW AGENT harmless against any loss, claim, damage, liability or expenses incurred in connection with any action, suit, proceeding, claim or alleged liability arising from this Escrow Agreement, provided, however, that the ESCROW AGENT shall not be so indemnified or held harmless for its negligence or acts of bad faith by it or any of its agents or employees.

ARTICLE VI
NOTICES

All notices and other communication shall be in writing and shall be deemed to have been duly given and delivered if mailed by certified mail, return receipt requested, postage prepaid to the addresses stated herein:

DEPARTMENT:

Contract Administration, Room No.: **No.**
South Carolina Department of Transportation
955 Park Street
Columbia, SC 29201

CONTRACTOR:

Company Name
Street Address
City/Town, State **Zip Code**

ESCROW AGENT:

Bank Name
Street Address
City/Town, State **Zip Code**

ARTICLE VII
DUTIES OF ESCROW AGENT

The duties and responsibilities of the ESCROW AGENT shall be limited to those expressly set forth herein and the ESCROW AGENT shall act only in accordance with this ESCROW Agreement. Notwithstanding specific provisions hereunder, the ESCROW AGENT shall at all times act upon and in accordance with the joint written instructions of the DEPARTMENT and CONTRACTOR.

ARTICLE VIII
LAWS

This Escrow Agreement shall be deemed to have been executed in RICHLAND County, South Carolina and the laws of the State of South Carolina shall apply.

ARTICLE IX
ASSIGNMENT

This Escrow Agreement shall not be assigned without the written consent of all the parties hereto.

ARTICLE X
SURVIVAL OF CONTRACT

Except as may be expressly modified, all terms and conditions of this Escrow Agreement remain in full force and effect. The establishment of this Escrow Agreement is limited solely by the contingency of release of the CONTRACT BID DOCUMENTS sealed container by the CONTRACTOR to the DEPARTMENT, as established by ARTICLE IV, RELEASE FROM ESCROW. Nothing contained herein shall alter the rights of the parties hereto.

The covenants herein contained shall, except as otherwise provided, accrue to the benefit of and be binding upon the successors and assigns of the parties hereto.

IN WITNESS WHEREOF, the parties have hereunto set their hands and seals the day above first written.

CONTRACTOR
Company Name
Representative's Name

ESCROW AGENT
Bank Name
Trust Officer's Name

By: Representative's Signature (Seal)

By: Trust Officer's Signature (Seal)

Witness's Signature
Witness

Witness's Signature
Witness

DEPARTMENT
Department Representative

By: Representative's Signature
Representative's Title

Witness's Signature
Witness

Exhibit A

**ESCROW RELEASE
FOR
CONTRACT BID DOCUMENTS**

This is to certify that on this Day day of Month, Year, the sealed container holding the BID DOCUMENTS for the following CONTRACT was release from escrow:

SC File No(s): Project File No(s).

CONTRACTOR: Company Name

Address: Street Address
City/Town, State Zip Code

Date BID DOCUMENTS put into Escrow: Agreement Date

The Representative for the ESCROW AGENT identified below, personally transferred the sealed container holding the BID DOCUMENTS to the Representative for the CONTRACTOR or the DEPARTMENT.

Acknowledgment of Release:

(Print Name)

Signature of Representative for U. S. Bank

The individual named below acknowledges receipt of the sealed container holding the BID DOCUMENTS.

Acknowledgment of Receipt:

(Print Name)

Signature of Representative for _____
Contractor Name

If the CONTRACTOR receives the sealed container holding the BID DOCUMENTS, the ESCROW AGENT will send a signed copy of this document to the DEPARTMENT.