

* Allowable shoulder width reduction at Overpasses only

Note:
Cross slopes and finished grades
will vary based on final design.

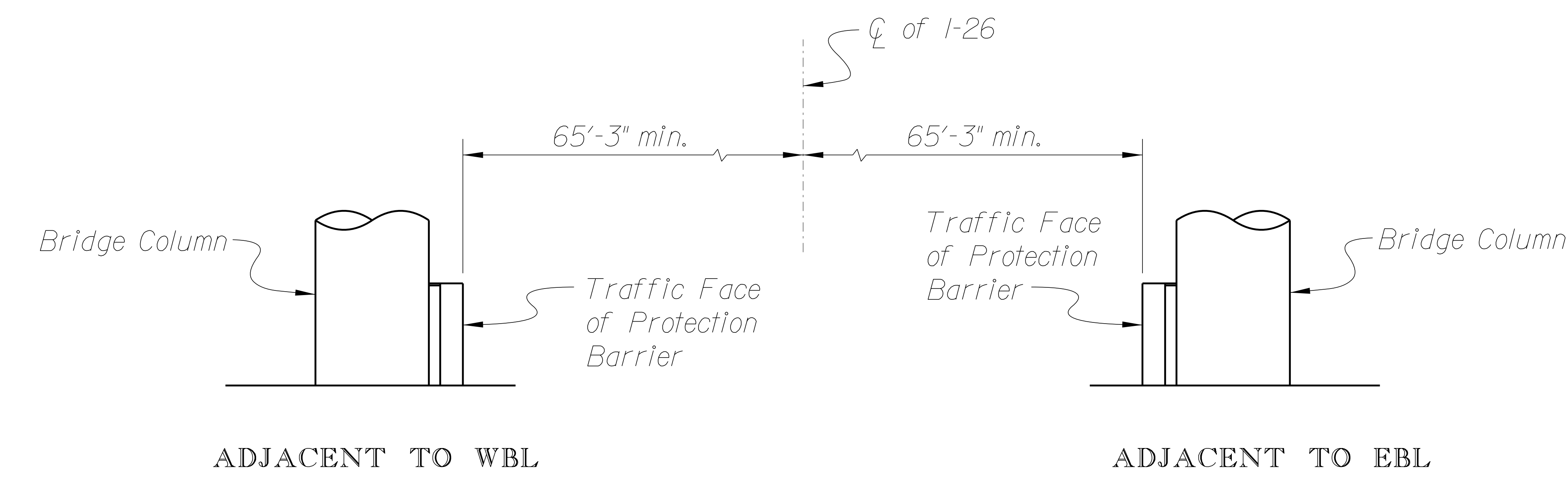

- ★ Permissible location of bridge column with protection barrier - See Detail A
- ★★ Permissible location of traffic face of barrier used to protect a wall or bridge substructure
- ★★★ Permissible location of bridge column with protection barrier - See Detail B

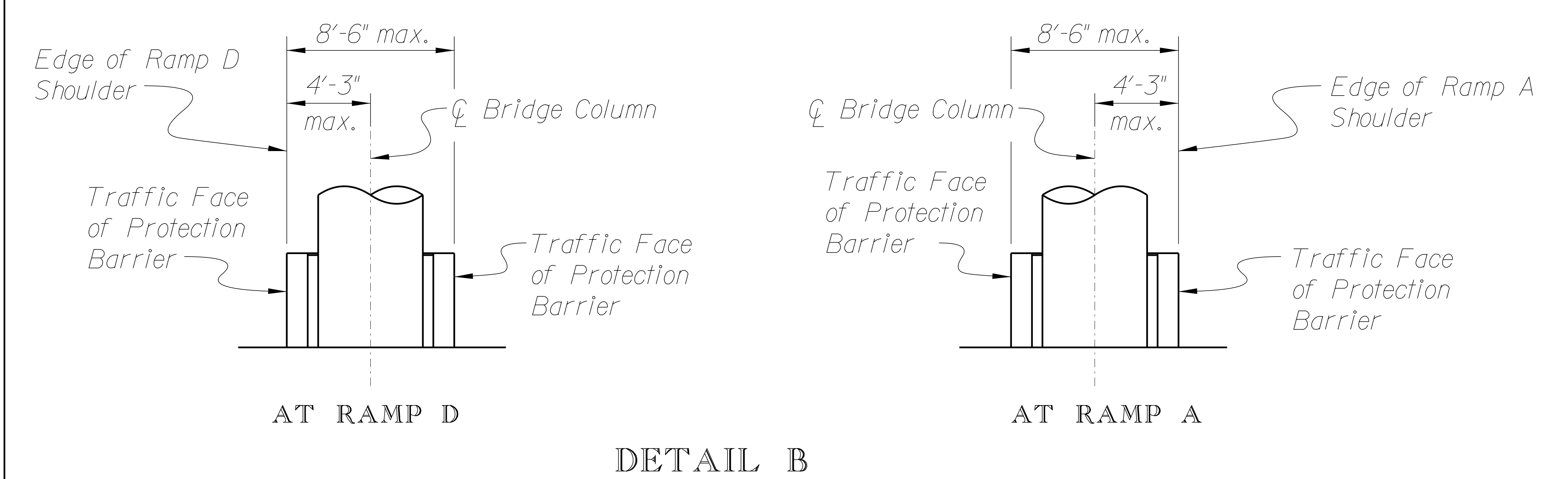
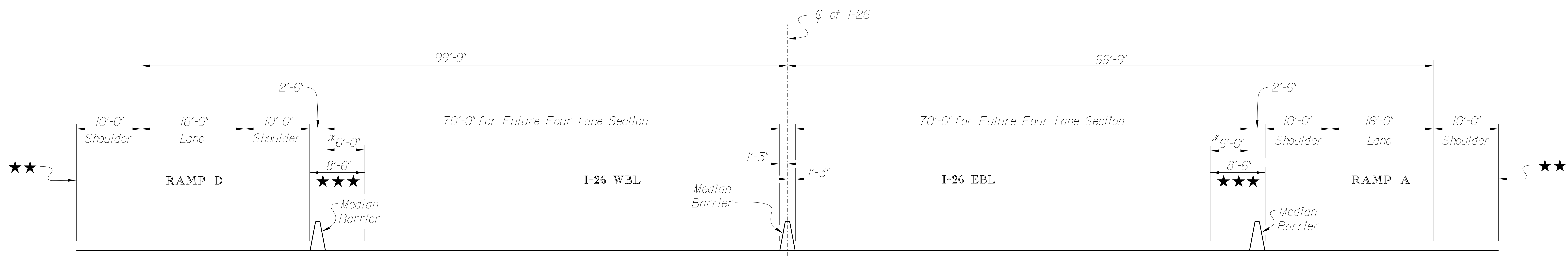

Bents are not allowed to be constructed at the centerline (in the median) of I-26. Shoulder width reductions at bridge columns, other than those noted on this drawing, are not allowed.

REV.				SOUTH CAROLINA DEPARTMENT OF TRANSPORTATION TYPICAL SECTIONS OF I-26 SHOWING FUTURE EIGHT LANE SECTION
REV.				
REV.				
REVIEWED				
QUAN.				
DR.				
DES.				
BY	CHK.	DATE	COUNTY	ROUTE
			Charleston	